

# ENDURO FRAME<sup>®</sup>



## ENDUROWALL<sup>®</sup> System Installation Manual

Find the latest version at <https://enduroframe.atlassian.net/wiki/display/IM/>

© BlueScope Steel Ltd.

1. 1.0 Scope of Manual	2
2. 2.0 On-site handling	4
3. 3.0 Tools & equipment	6
4. 4.0 General points before construction begins	9
5. 5.0 Definition of terms - part identification	13
6. 6.0 ENDUROWALL® Frame Assembly	15
7. 7.0 ENDUROWALL® Wall construction	42
8. 7.4 Wall frame Installation	46
9. 7.6 Typical non cyclonic hold down connections	60
10. 7.8 Fasteners	64
11. 8.0 References	67

© BlueScope Steel Ltd

# 1.0 Scope of Manual

This manual has been prepared for the construction of steel framed walls within the following parameters:

Only ENDUROWALL® components made from TRUECORE® steel and made with the ENDURO® rollformer can be used.

Erection details in this manual covers construction for non-cyclonic buildings. (See Table below.) **Cyclonic design is site specific and should be detailed by the design engineer.**

Standard stud spacings are at 600mm or 450mm (max) centres dependent on stud design limitations. Other spacings may require additional engineering.

Suitable for both sheet wall cladding and brick veneer construction.

## Product performance

The ENDUROWALL® wall framing system has been designed in accordance with relevant Australian Standards and the requirements of the Building Code of Australia.

The wall framing system will perform in accordance with ENDUROWALL® design documentation if installed in accordance with the recommendations and details set down in this manual and related references.

This manual contains vital information. Please read it carefully.

For more information and technical support, contact: [www.enduroframe.com](http://www.enduroframe.com)

Refer to [www.truecore.com.au](http://www.truecore.com.au) for locations where ENDUROFRAME® can be warranted.

## Reference Standards

AS/NZS 4600:2005 – Cold Formed Steel Structures

AS/NZS 1170.0:2011 – Structural Design Actions, Part 0 - General Principles

AS/NZS 1170.1:2011 – Structural Design Actions, Part 1 - Permanent, Imposed or Other Actions

AS/NZS 1170.2 :2011 – Structural Design Actions, Part 2 - Wind Actions

AS 4055:2012 – Wind Loads for Housing

AS1397:2011 – Continuous hot-dip metallic coated steel sheet and strip - Coatings of zinc and zinc alloyed with aluminium and magnesium

NASH Standard Residential and Low Rise Steel Framing: Part 1, Design Criteria

### Design Gust Wind Speed ( $V_h$ ) for classification

Wind Class		Design Gust Wind Speed ( $V_h$ ) at height (h) (m/sec.)	
Regions A & B (non cyclonic)	Regions C & D (cyclonic)	Serviceability Limit State ( $V_{h,s}$ )	Ultimate Limit State ( $V_{h,u}$ )
N1	—	26	34
N2	—	26	40
N3	C1	32	50
N4	C2	39	61
N5	C3	47	74
N6	C4	55	86

Taken from AS4055:2006 Table 2.1

### The smart, simple solution to wall framing.

#### General notes to be read before you use this manual.

1. This Manual has been prepared for a range of roof framing designs using ENDUROWALL® building components manufactured or supplied by BlueScope Steel, its licensed manufacturers or dealers.
2. The ENDUROFRAME® Building System has been designed as a complete framing system.
3. All erection and connection details must be made in accordance with the relevant standard connection drawing details contained in this Manual or its supplements, or drawings output from the ENDUROCAD® software.
4. Before commencement of any fabrication or construction develop a safety management plan to cover key risks. Key risks include, but are not limited to:-
  - a. Working at heights
  - b. Electrical safety
  - c. Cuts and scratches
5. Consider and install the appropriate level of safety equipment to manage identified risks. Safety equipment that may be required includes:-
  - a. Personal protective equipment including safety glasses, gloves, hearing protection (when using power tools) and sunscreen;
  - b. Appropriate fall protection equipment including guard rails, scaffolds, ladders, elevated platforms, safety mesh, and fall restraint harnesses
6. A temporary earth should be established during the construction of steel frames and, upon completion, the steel house frames must be permanently earthed in accordance with the requirements of local electricity authorities.

7. You should check with your local workplace health and safety authority to see what safety measures you need to put in place prior to and during construction. It is the responsibility of the installer/erector to ensure all local safe work practices are adhered to and the safety of the whole site is maintained at all times.

8. For wiring in steel wall frames, nylon grommets shall be installed to run electrical cables through.

Where insufficient detail is included in this manual for your project, seek specialist advice.

9. Before you commence construction:

- a. You should check with your local government authority to see if any form of prior permission or approval is required;
- b. If you want to build or construct any attached structure, you should seek advice from a suitably qualified engineer to verify the capacity of your existing structure to withstand any additional load arising from the attached structure. You should also check with your local government authority to determine any specific requirements for the attachment to existing structures;
- c. You should check with your local workplace health and safety authority to see what safety measures you need to put in place prior to and during construction. It is the responsibility of the installer/erector to ensure all local safe work practices are adhered to and the safety of the whole site is maintained at all times.

6. To ensure maximum lifespan of your house frame, consult your nearest ENDUROFRAME® fabricator for information regarding maintenance, handling, storage and any other technical assistance you may require.

#### **Important disclaimer about this construction manual**

##### **Date of Issue**

This Manual was issued on September, 2014. BlueScope Steel may make changes to this Manual in its sole discretion. You should check you are using the current version of the Manual before you start construction. Refer to [www.enduroframe.com](http://www.enduroframe.com) to check for the latest version.

##### **Conditions of Use**

If you use this Manual, you acknowledge and agree that your use is subject to the terms and conditions in this Manual. BlueScope Steel, its agents, officers, employees, subcontractors or consultants make no representations, either expressed or implied, as to the suitability of the information and data in this Manual for your particular purposes. It's your responsibility to ensure the design you use is appropriate for your needs, the products you have purchased, your site and structural limitations and your building and construction capabilities. It is recommended that you obtain qualified expert advice.

##### **Use of Genuine Materials**

Structures in this Manual should only be built or constructed using ENDUROWALL® made from TRUECORE® steel and made with the ENDURO® rollformer or recommended third party products. Except as otherwise provided in these terms, any warranties only apply to you (if at all) if you use the genuine BlueScope Steel or recommended third party products and method of construction.

##### **Check Delivery**

It is important that you check all materials delivered to site against your invoice before you use them in your building or construction to ensure all components have arrived, are of the appropriate quality and are ready for installation.

##### **Limitation of Liability**

By using this Manual, you accept the risks and responsibility for all losses, damages, costs and other consequences resulting directly or indirectly from using this Manual. Except to the extent to which liability may not lawfully be excluded or limited, BlueScope Steel will not be under or incur any liability to any person for any direct or indirect loss or damage (including, without limitation, consequential loss or damage such as loss of profit or anticipated profit, loss of use, damage to goodwill and loss due to delay) however caused (including, without limitation, breach of contract, negligence, breach of statute and/or in equity), which may be suffered or incurred in connection with this Manual.

All rights reserved. No part of this brochure may be reproduced, stored in a retrieval system, or transmitted in any form or by any means, electronic, mechanical, recording or otherwise, without written permission of BlueScopeSteel Limited. ABN 16 000 011 058



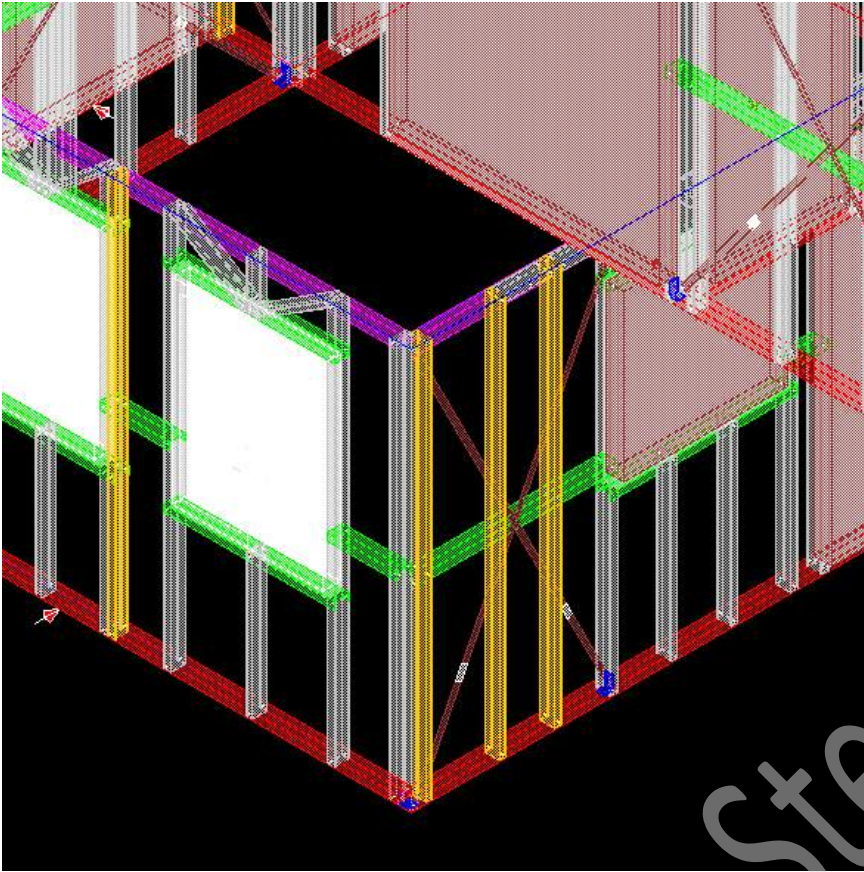

## 2.0 On-site handling

### Slings

Lifting, loading and transportation of steel frames shall be accomplished with sufficient care to prevent damage. Frames must be fully supported in either horizontal or vertical planes when being transported. Care must be taken when tying down and lifting wall frames not to put an excessive pressure on joints.

Most wall frames for single storey work may be lifted by hand, however where cranes are required, sling frames at plate and stud connections. When a crane is used to unload, suitable lifting methods are required to minimise racking loads or local distortion of members.

Slings should be located at equal distances from frame centrelines and be approximately one-third to one-half the frame length apart.

Note: When maneuvering any materials by hand, take care not to damage components. Components should be inspected on arrival to site. Damaged components may affect structural integrity.

## 2.1 Wall Frame Exposure & Storage

### 2.1.1 On-site storage

Where frames are stored on site, they should be blocked above the firm ground to protect them from ground water as follows:

- If the frames are stored horizontally, the blocking should be at 1.0m to 1.5m centres or as required at joints, to prevent bending of the frames. (Figure 2.2.2)
- If the frames are stored vertically, they should be supported at the designed support locations and in a manner that will prevent them from tipping or toppling. (Figure 2.2.1)







Figure 2.2.1 Frames stacked vertically



Figure 2.2.2 Frames stacked horizontally

## 3.0 Tools & equipment

### Power tools

- Rotary hammer drill (for concrete drilling up to  $\varnothing 20\text{mm}$ ) plus appropriate drill bits to suit drill and anchor fixing
- 150mm hand held grinder and metal blades to suit
- Explosive powered (Ramset type) nailing gun, preferably with collated charges for shooting plates to concrete (plus mickey pins and nails)
- Cordless impact drivers each with driver tips to suit framing screws, and/or
- Cordless drills with torque settings and driver tips to suit
- Minimum 185mm portable circular saw

- Min 250mm metal cut off saw and blades

**Tool accessories**

- 15 amp electrical safety pack and electrical leads (of suitable length)
- 5/16" driver tips to suit hex type
- No.3 Phillips bits
- Spanner & socket sets
- Screw gun Extension bit (length up to 150mm)

**Hand tools**

- Double action Tin snips (2 pair each left hand and righthand)
- 2000 mm spirit level and 1200mm spirit level
- Pack 10 oil based marker pens (Fine)
- String lines (chalked & unchalked) and line marking chalk
- Adjustable G cramps / vice grips
- Measuring Tapes
- Hammer
- Hacksaw and blades
- Old carpenters chisel
- Suitable cold chisel
- Duck bill pliers

**Essential safety equipment**

- 2400mm high step ladders
- Fall protection harness
- Carpenters trestles (saw horses) 750mm or 900mm in height
- 3600mm high aluminium trestles
- 5000mm aluminium planks
- Ply sheeting 2700mm x 1200mm x 15mm (Make platform for fabrication and re-use as scaffold deck for installation)
- Eye protection
- Hearing protection (when using power tools)
- Protective gloves
- Earth leakage circuit breaker for electrical tools



Tin Snips





Metal cutting saw



Angle grinder



Screw gun (shown with extended hex head bit)



Hand held metal cutting saw

## 4.0 General points before construction begins

### Material Specifications

Sections are roll-formed from TRUECORE® steel complying with AS1397:2011. In the grade shown, the number prefixed with G indicates minimum yield stress in MPa; and the number prefixed with Z or AM indicates minimum coating mass in g/m<sup>2</sup>.

- 0.55mm BMT, TRUECORE® G550 AM125 steel
- 0.75mm BMT, TRUECORE® G550 AM125 steel
- 1.0mm BMT, TRUECORE® G550 AM125 steel

- 1.2mm BMT, TRUECORE® G550 AM125 steel

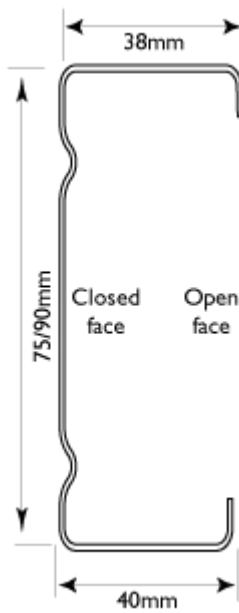

#### Ribbed Cee Section

Thicknesses: 0.55mm, 0.75mm, 1.0mm and 1.2mm  
Figure 4.1 Section dimensions

## 4.1 Frame and Slab\_Sub-Floor dimensions MUST be compatible

Check that the ENDUROCAD® generated layout matches the building and that all setout dimensions and identification marks have been provided.

Measure your slab or oor platform to ensure the frame will sit comfortably within its dimensions. This will highlight any discrepancies between the two that must be catered for during set-out.

Slab tolerances are essential because if length, flatness and square of the slab are incorrect, then the frame will not fit together correctly.

### 4.1.1 Concrete specification

#### Slabs

Maximum deviation from any specified height, plan or cross-sectional dimension to be greater of 1/200 times specified dimension or 5mm in accordance with AS3600. Surface level to be within +/-5mm of specified level. Exposed edges to be Class 3 in accordance with AS3610. Flatness - maximum deviation from a 3m straight edge placed anywhere on the surface: 5mm.

#### Footings - Exposed

"As for 'concealed' above plus - Maximum deviation from plumb to be greater of 1/200 times specified dimension or 5mm in accordance with AS3600. Maximum deviation of any point on the surface from a straight line joining any two points on the surface to be the greater of 1/250 times length of the line or 10mm in accordance with AS3600.

#### Concrete Columns & Walls

Within +/-15mm of specified position and +/-5mm of plumb.

## 4.2 Frame Set-out must be as per correct plan

Set-out must be made using the architectural plans to ensure all relevant measurements are transferred to the slab/sub-oor.

## 4.3 Frames must be installed right way up and facing the right direction

The ENDUROCAD® wall frame numbering system and wall framing layout will ensure each wall frame is installed correctly on-site. Markings on the plates indicate the front of the panel as shown by the arrow on the layout drawings.



## 4.4 Site modifications must be checked

Minor modifications to wall frames are easily made on-site if required. However, check with the design engineer for any structural implications.

## 4.5 Statutory Regulations must be adhered to

Following trades must ensure that all statutory regulations are complied with during the construction process.

## 4.6 Correct direction of ENDUROWALL profile

The direction of the channel section used for the frame should be as depicted on Frame Assembly diagrams in Figure 6.2.

## 4.7 Frames must be installed plumb & straight

While erecting the wall, frames must be fixed plumb and straight. After fixing, if a bow or tilt is evident, the frames have not been installed correctly. In this case, the problem must be rectified before proceeding further.

### 4.7.1 Straightness

Walls, specified as straight, must not deviate by more than 5mm over a 3m length as shown in Figure 4.2. Where wall panels join for form a continuous wall, the critical face or faces of the panel must not deviate by more than +/- 2mm at the joint.

### 4.7.2 Plumb

Out of plumb at any point along the length of the wall frame from top to bottom, must not exceed the minimum of  $h/600$  or 3mm unless the frames are specifically designed to be installed out of plumb. (See Figure 4.3 at right) Columns & Walls must be within +/-15mm of specified position and +/-5mm of plumb

#### 4.7.2.1 Square the frames

Square the frames by measuring diagonals for equal dimensions or 3,4,5 check or by clamping into a square jig.

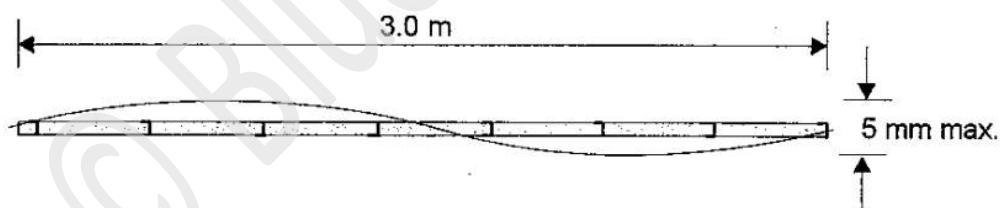

Figure 4.2 Straightness

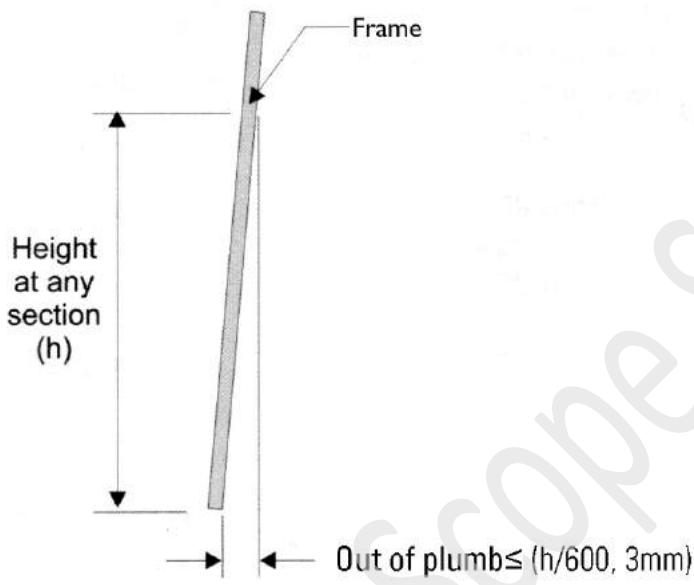
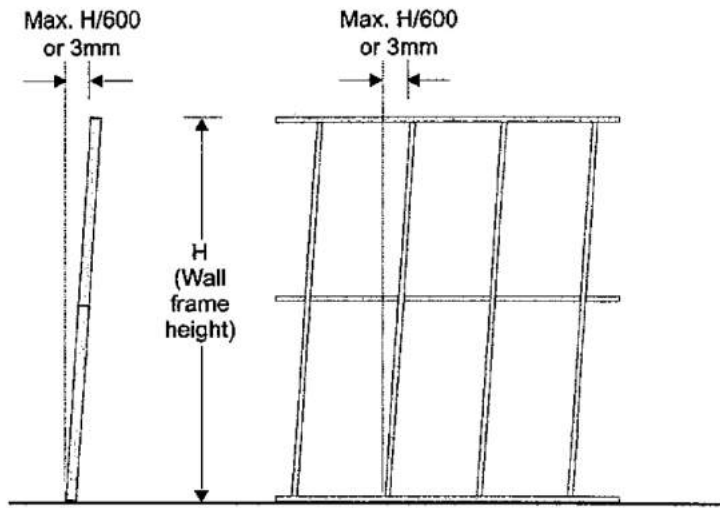

Figure 4.3 Plumb

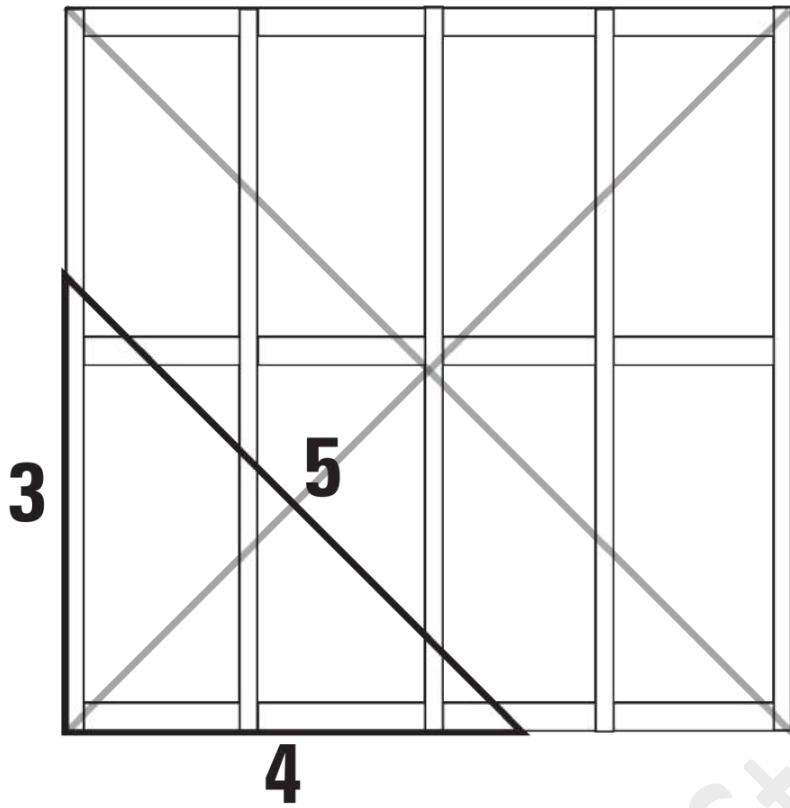
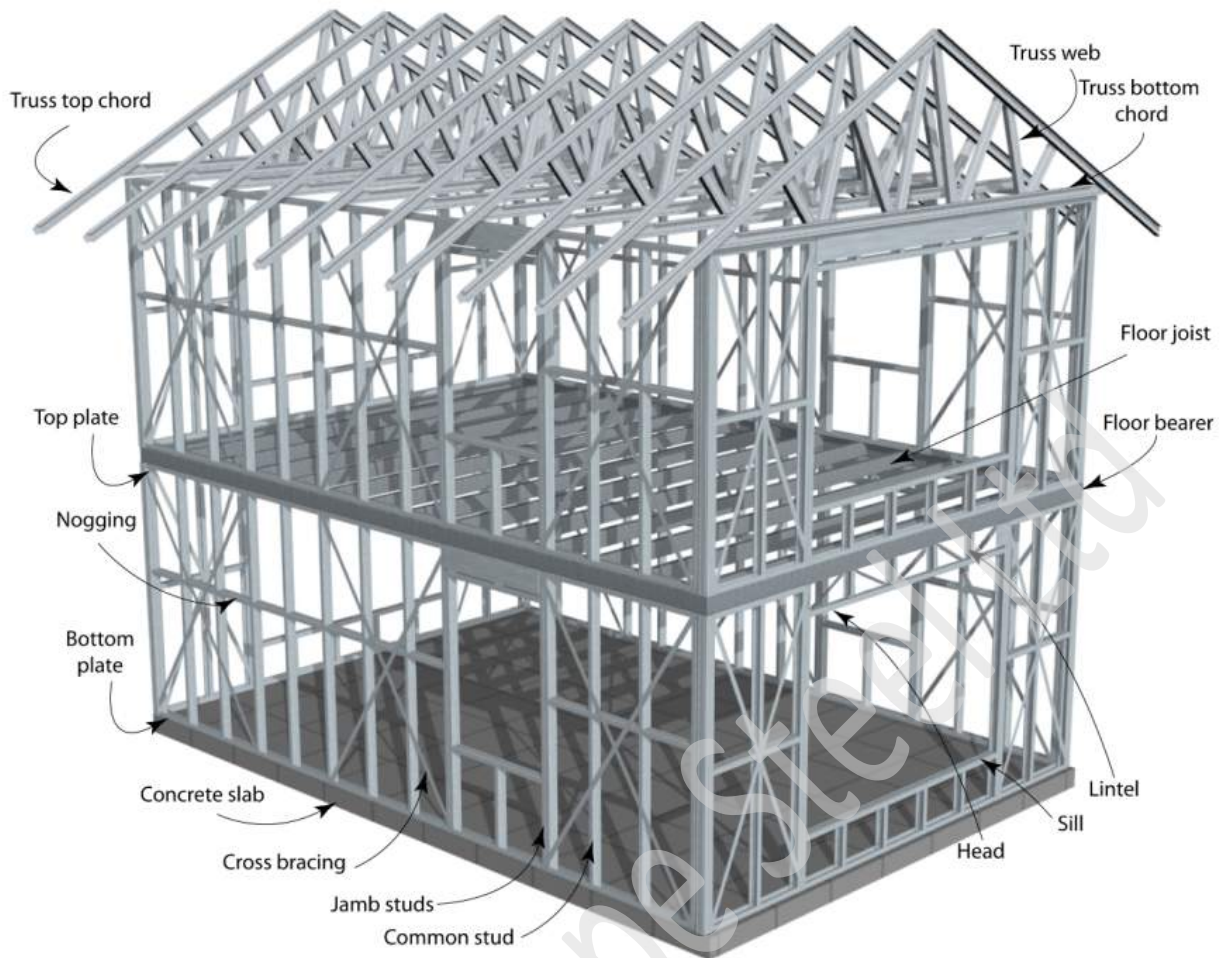

Figure 4.3.1 Square the frames

## 5.0 Definition of terms - part identification





## 5.1 Definition of Terms

**Load Bearing Wall:** A Load Bearing wall is one which carries vertical loads from the construction above or lateral loads resulting from the wind. These loads may act separately or in combination. Both internal and external walls may be load bearing.

**Non-Load Bearing walls:** Internal walls which do not support truss loads are considered non load-bearing. However internal walls may be used as lateral bracing walls.

**Common studs:** These studs support the vertical loads applied to the top wall plates by rafters and trusses, ceiling joists and horizontal wind and seismic loads.

**Jamb Studs:** These studs are provided on each side of an opening. They support loads from lintel over the opening and the horizontal wind load across the width of the opening.

**Studs supporting concentrated loads:** These studs are installed in addition to common studs (or jamb studs) to carry concentrated vertical loads arising from support for principal roof and floor supporting members.

**Nogging:** Noggings provide lateral and torsional restraint to the studs. In addition nogging must be designed to support an imposed concentrated load of 1.1 kN placed anywhere on its span to produce the maximum action effect during construction.

**Wall Plates:** Load bearing wall plates are designed to transfer vertical loads to studs when the trusses or floor joists are not directly in line with the studs. Wall Plates are not designed to transfer horizontal loads vertically to brace walls. Ceiling and floor diaphragms perform this function.

The reaction due to roof or floor loads may be ignored in the design of the plates if the system is such that the loads are transferred directly to the studs.

**Lintels:** Lintels are designed to transfer vertical loads applied over the opening to the jamb studs on the sides of the opening.

Lintels in single and upper storey walls are designed to support rafters, trusses or any other load carrying members that are located over the opening.

Lintels in lower storey walls of two storey construction are designed to support the loads from the wall above including the roof loads and floor loads from the storey above.

Lintels can be designed as a part of a system that includes top wall plates and other structural components located directly above and connected to the lintel.

**Wall Bracing:** Wall bracings are required to transfer all the horizontal forces from roof, walls and floors to the appropriate ceiling and floor diaphragms. These forces arise from wind or earthquake loads.

Bracing may be strap, channel or membrane type. Membranes may be flat or profiled steel, fibre cement, timber ply or plaster board.

**Foundation Connection:** Hold down fixings between wall plate and adjoining floor structure.

**Tie-Down:** Framing connection used to both locate frame components and resist wind uplift forces.

## 6.0 ENDUROWALL® Frame Assembly

### 6.1 ENDUROWALL® Marking & Branding

All ENDUROWALL® parts are coded with information to assist erectors in the assembly process. This matches the part information shown on the assembly drawings.

All ENDUROWALL® parts are coded in the following order:

Job Name/Number, Frame Number, Part Number and Part Usage. For short parts, some of this information is deleted.

With this information, erectors can identify what the part is and where it is intended to be used in the structure. The illustration below shows how the coding works:

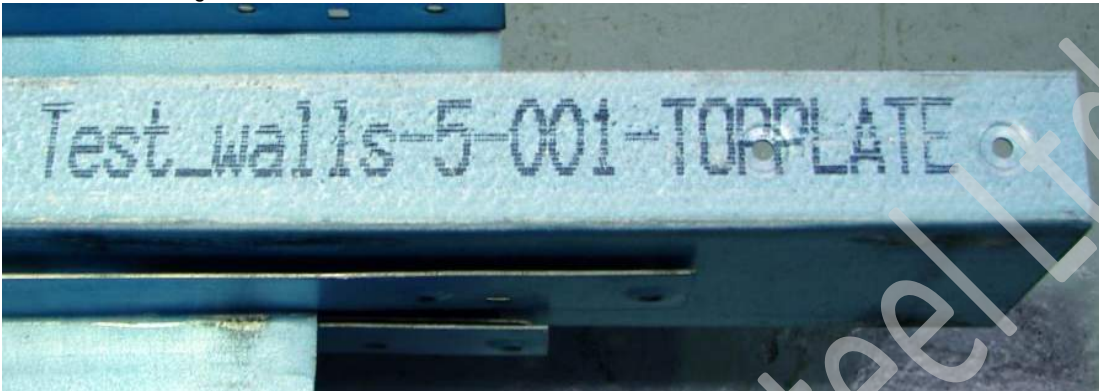

**Figure 6.1 Marking and branding**

Job name/number is Test Walls, 5 is the panel number, 001 is the part number and Topplate is usage.

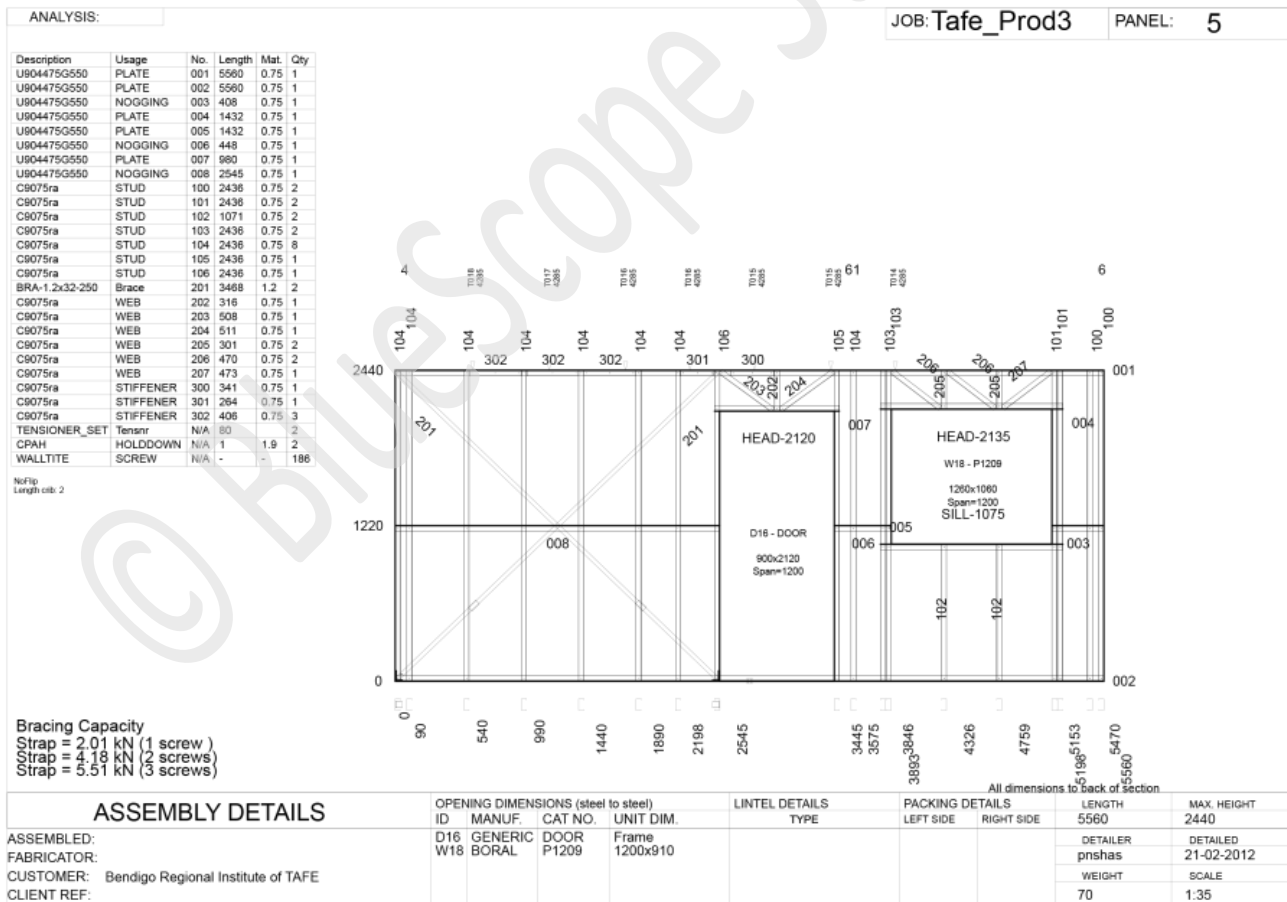

**Figure 6.2** A typical wall frame assembly sheet as produced by ENDUROCADD®. The sections are branded when produced in accordance with Section 6.1 of this manual.

## 6.3 ENDUROWALL® Assembly Procedure

ENDUROWALL® is generally factory assembled or assembly by a third party from completely knocked down (CKD) packs. The following illustrations show the typical steps for site assembly of a wall frame.

### 6.3.1 Preliminary work

It is important that you check all components delivered on-site against your 'Delivery Packing List' to ensure complete delivery.

#### **Step 1 Part Identification**

Unpack the frames and sort frames into frame lots using the branding as a manual. Identify the studs from the branding information on the parts.



Wall & truss framing will be plastic wrapped & labelled in bundles as registered on packing list





Wall frames are individually strapped & stacked in "stud" bundles, labelled with bundle numbers



Matching frames in "nogging, top & bottom plate" bundles, labelled with bundle numbers





Accessories will be consolidated on pallets or in boxes as registered on the packing list.



Accessories bundles to be checked upon delivery.





Sort & stack all accessories, cross check packing list. (helps to mark on box's, where accessories are to be used)

### 6.3.2 Frame Layout & Assembly (Step 2)

Identify the studs and lay toes down on a level surface and align as per assembly drawing. The heads, sills and noggings should be pre-notched allowing parts to overlap as shown. Pre-punched holes are provided for trilobular fastener screws to connect the frames.





Locate & open matching stud & nogging / plate bundles before separating into individual frame packs.



Separate and move stud & nogging / plate frame packs next to designated assembly zone.



Lift & separate stud pack onto assembly table (this example has utilised Topspan<sup>®</sup> 40 sections on concrete block stacks as an assembly table).

**Identify and separate Endurotie<sup>®</sup> bent tab studs (90mm system only)**

The Endurotie<sup>®</sup> bent tab studs can be identified by the extension of the stud web section and double 15mm hole punch for insertion of a frame anchor bolt (or similar).

### Prepare bent tab studs

- Place the stud with the web down.
- With a small cold chisel and a hammer, flatten the ribs on the rib in line with the stud flange.
- With a pair of duck bill pliers, bend the tab in the appropriate direction. (Refer to layout plan provided with job outputs.)



Layout all studs in sequential order, space out & orientate frame as per assembly sheet.



Fix all studs by inserting into top plate on approx. 45deg angle.





Align holes, fix at studs and install trilobular fastener.



**Step 3 Fix at Studs**

When carrying out the primary assembly of the frame align notch holes as shown and install trilobular fastener in holes. Align top of studs & screw fix top plate at both ends. (Where utilised, ensure Endurotie® bent tab studs are placed in the correct location and orientation.



Twist stud into position & align fixing holes – repeat for all studs along top plate.

**Step 4 -Fix at corner and install a trilobular fastener**

Align notch holes as shown and install trilobular fastener in holes.





Slide noggings onto the studs from base of frame & align fixing holes. May require 2 people to slide up studs evenly.



Fix bottom plate to studs, align holes & screw fix all noggings & bottom plate connections on "Side A". (Easier to fix bottom plate on an angle, starting at one end & pinching studs into plate, working along the frame). Ensure Endurotie® bent tab stud alignment is correct.





**Nogging Installation**

Position each one over the frame near their final location. Nogging height is specified in the supplied ENDUROCADD® panel drawings with the reference line to the centre line of the nogging.



Nogging installation.

In-line noggling with automatic features.

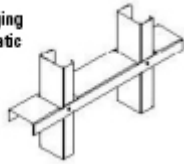

Strip (Omega) noggling through service holes.

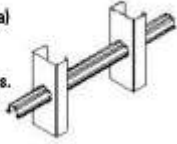

### Step 5 -Frame assembly - fix both sides

In order to process walls efficiently, two assembly tables situated side-by-side allows walls to be flipped over so both sides can be fixed off.



Cross check "Side A" frame layout & connections as per assembly sheet. Utilizing sufficient labour, lift & flip frame for "Side B" screw fixings.





Ensure sufficient labour available on both sides of frame to flip safely.



By utilizing two adjoining assembly tables, wall fabrication can be optimized by preparing the next frame while screw fixing & checking "Side B".

**Step 6 - Marking wall frames and prepare for openings**

Before inserting any bracing or lintels, check the overall dimensions of the frame against the supplied Assembly Sheet. Square the frame before installing any bracing.

**Marking frames**

Frames should be identified with panel number and the number of any adjoining walls at the appropriate locations. These marks should be applied to the side of the bottom plate.

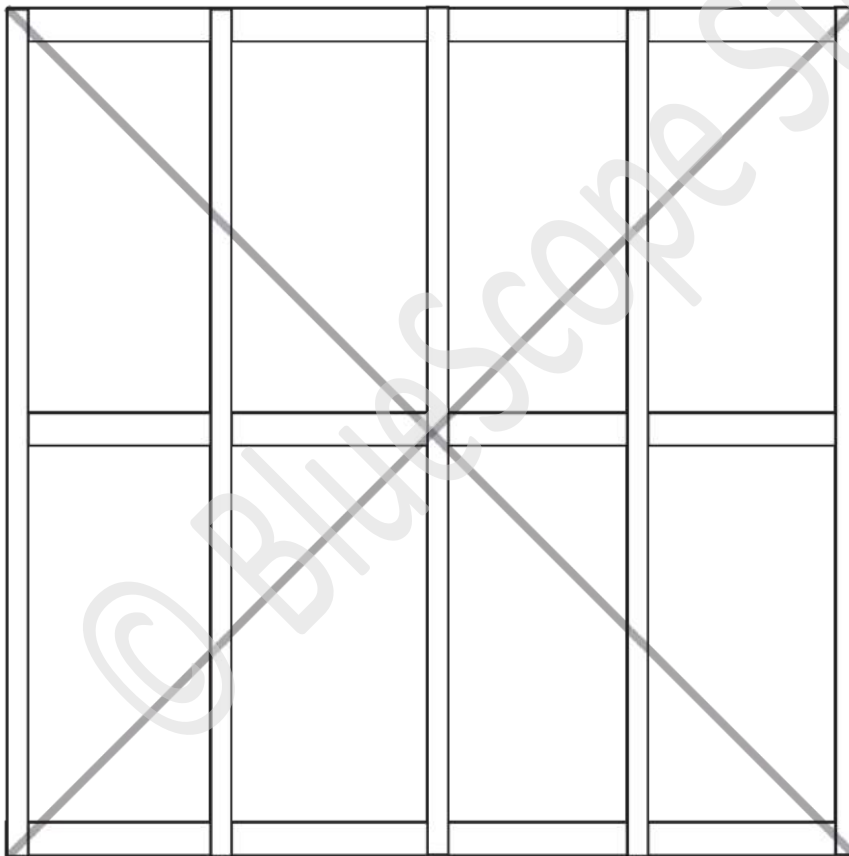

Install cross bracing as per wall assembly sheet using the nominated number of screws.  
Number each completed wall frame & mark the bracing locations to top & base of frames as per assembly sheet.  
Located the pre-cut notch and use tin snips to prepare the tab prior to installation. (This enables easy removal of bottom plate at openings after frame installation). After panel is checked for squareness, screw fix bracing strap to wall plates as per wall frame assembly sheet.  
Alternate bracing types are fixed in a similar manner.



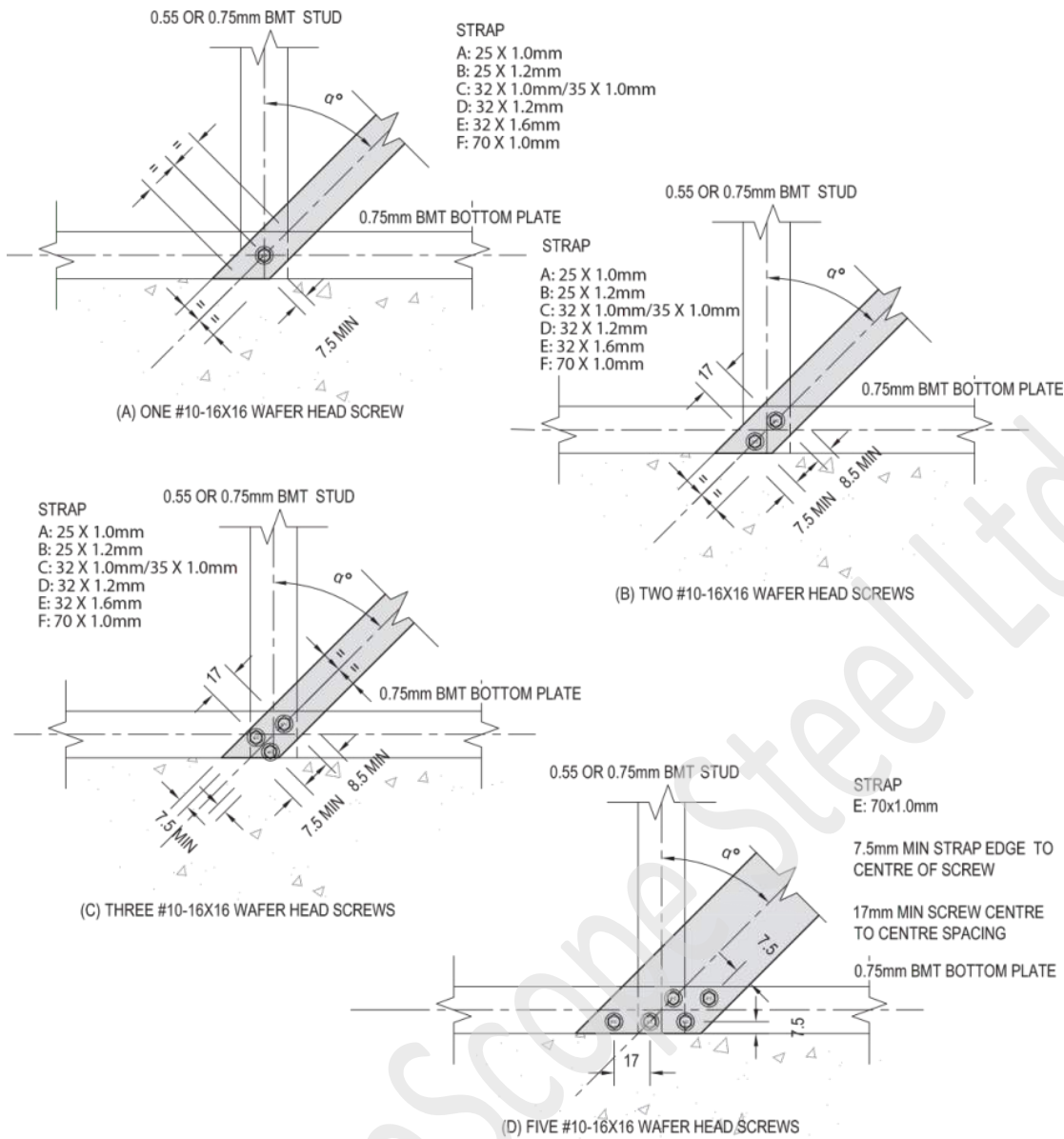

**Figure 6.3 - Connection details of diagonal tension strap bracing**

Note: 70mm strap brace requires two tensioners.

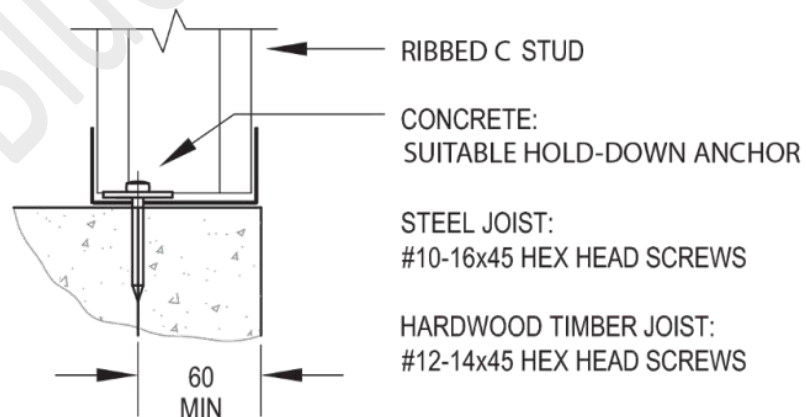

**Figure 6.4 Nominal Stud Tie-down**

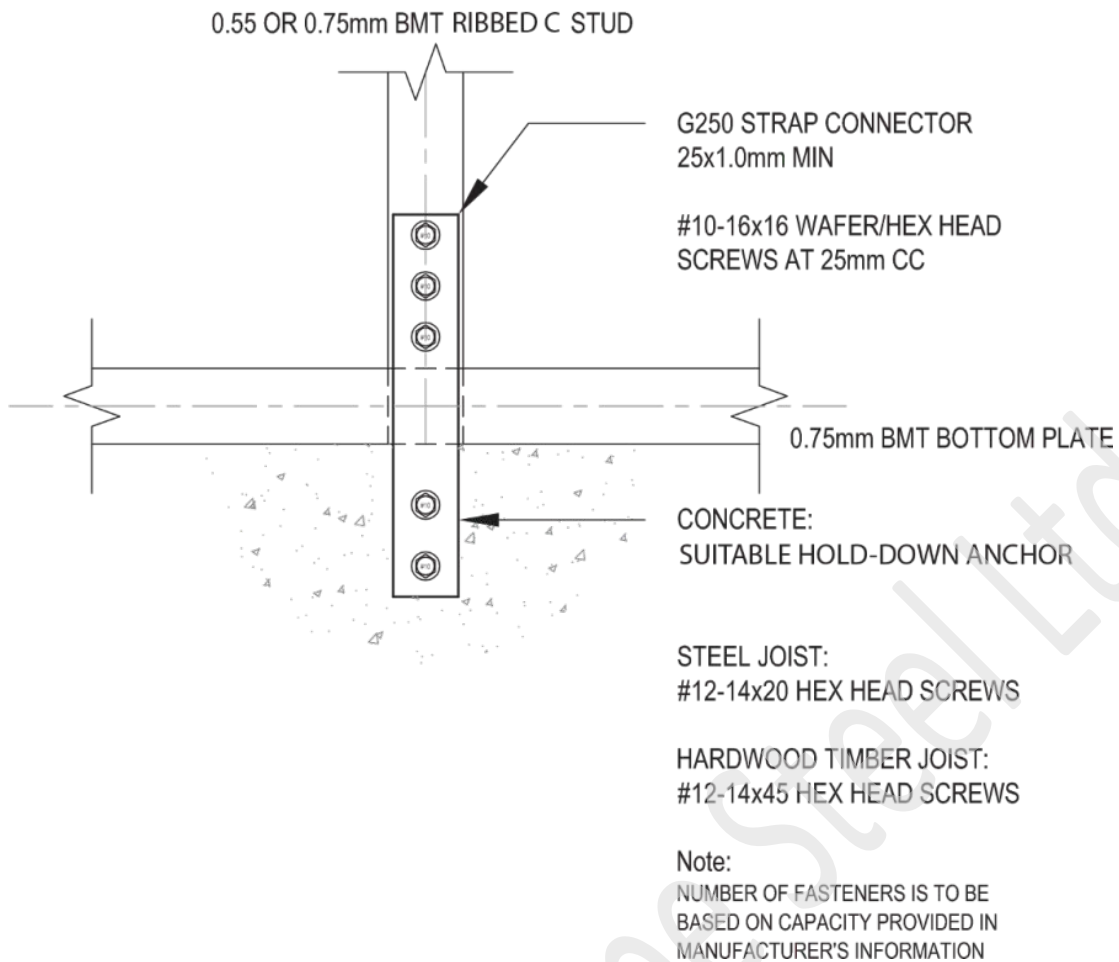

Figure 6.5 Strap connection options

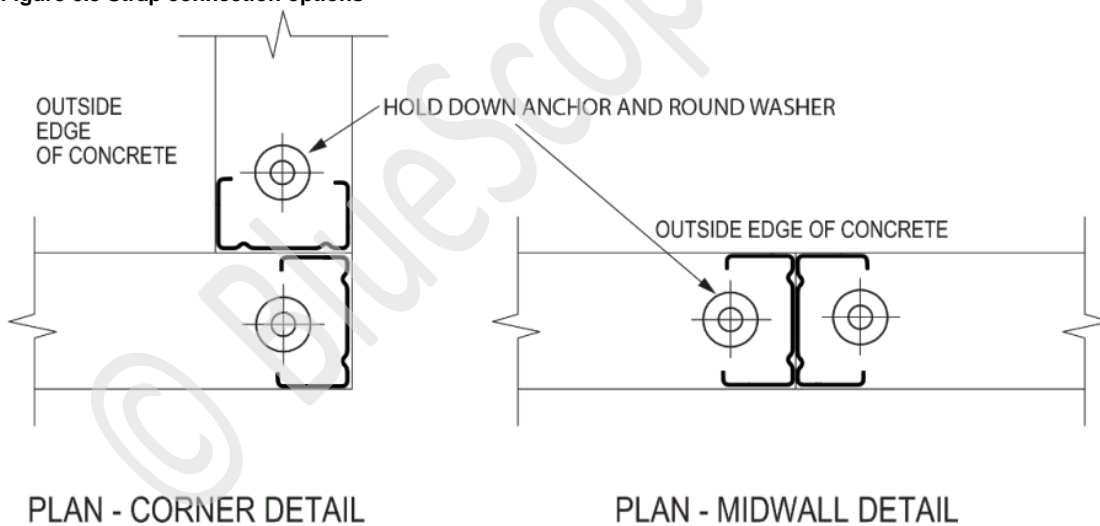
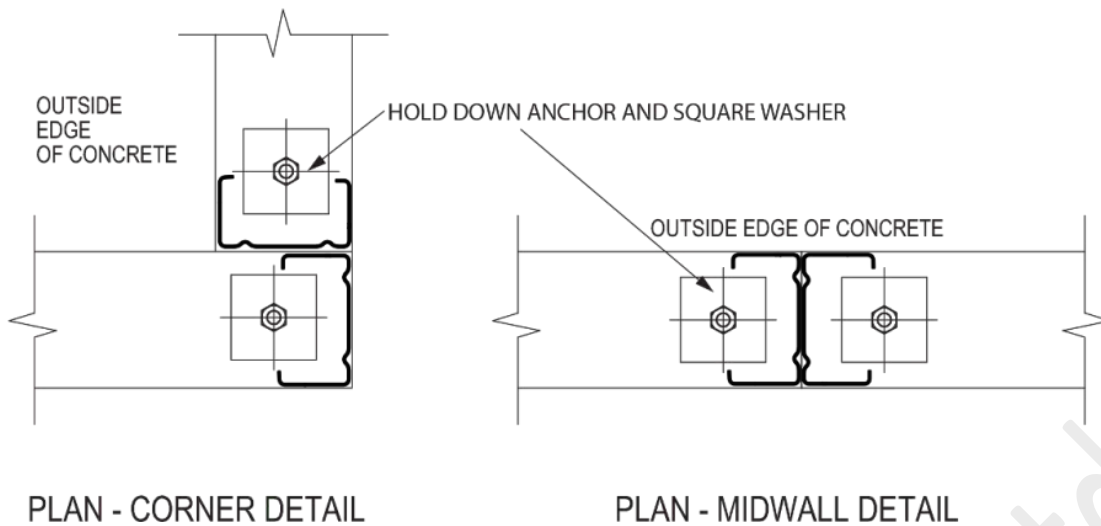

Figure 6.6 - Corner/Mid-wall Detail (Hold-down anchor and square washer)

For hold down anchor capacity, refer to manufacturer's information.

Suitable hold down anchors are to be provided to resist the uplift forces. Refer Table p22-23.



**Figure 6.7 - Corner/Mid-wall Detail (Hold-down anchor, bracket and washer)**  
 For hold down anchor capacity, refer to manufacturer's information.  
 Suitable hold down anchors are to be provided to resist the uplift forces. Refer Table p22-23.

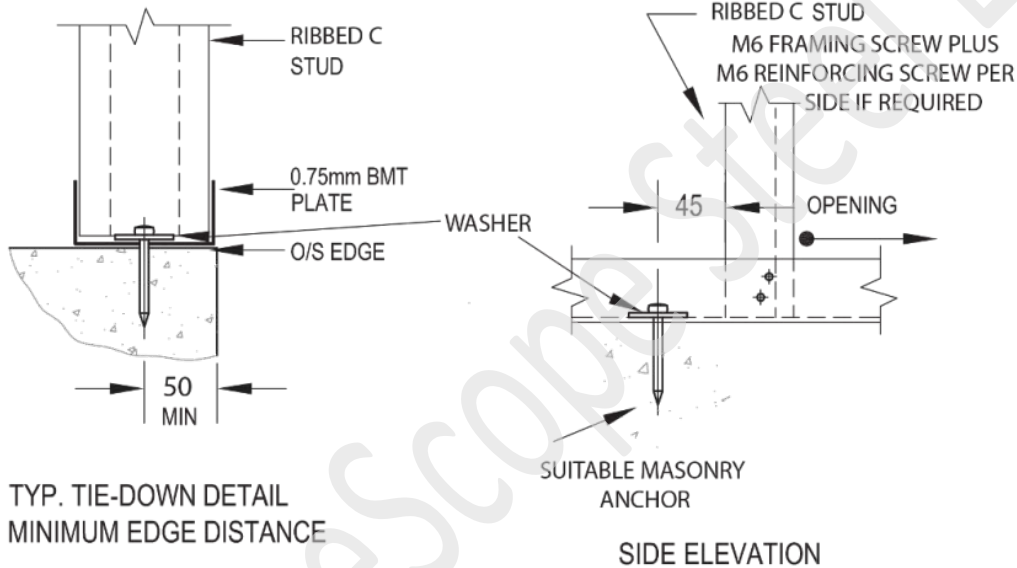

**Figure 6.6 Tie-down details - Masonry anchors with washers (low uplift capacity - 4.8kN Limit State)**  
 For hold down anchor capacity, refer to manufacturer's information.  
 Suitable hold down anchors are to be provided to resist the uplift forces defined in Tables 2-5 of Section 3.3.1 of the ENDUROWALL® Building System Design Manual.

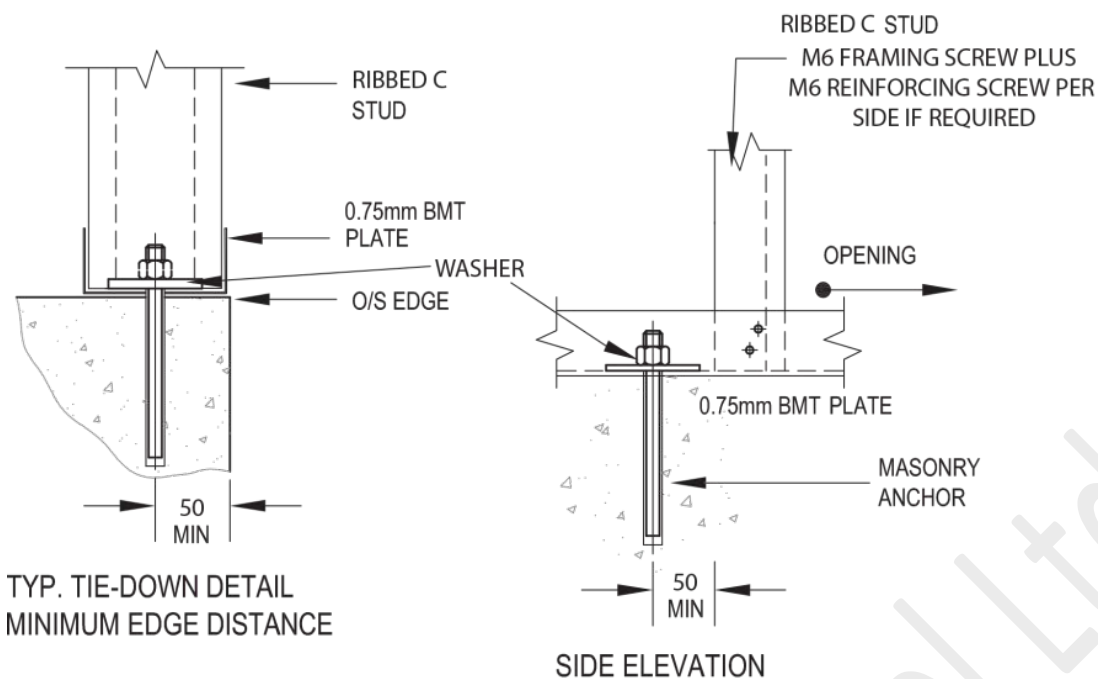

### TYPE C 10 TIE-DOWN - MASONRY ANCHOR WITH WASHER

**Figure 6.7 Tie-down details - Masonry anchors with washers (medium uplift capacity - 7.5kN Limit State)**

For hold down anchor capacity, refer to manufacturer's information.

Suitable hold down anchors are to be provided to resist the uplift forces defined in Table in Tables 2-5 of Section 3.3.1 of the ENDUROWALL® Building System Design Manual.

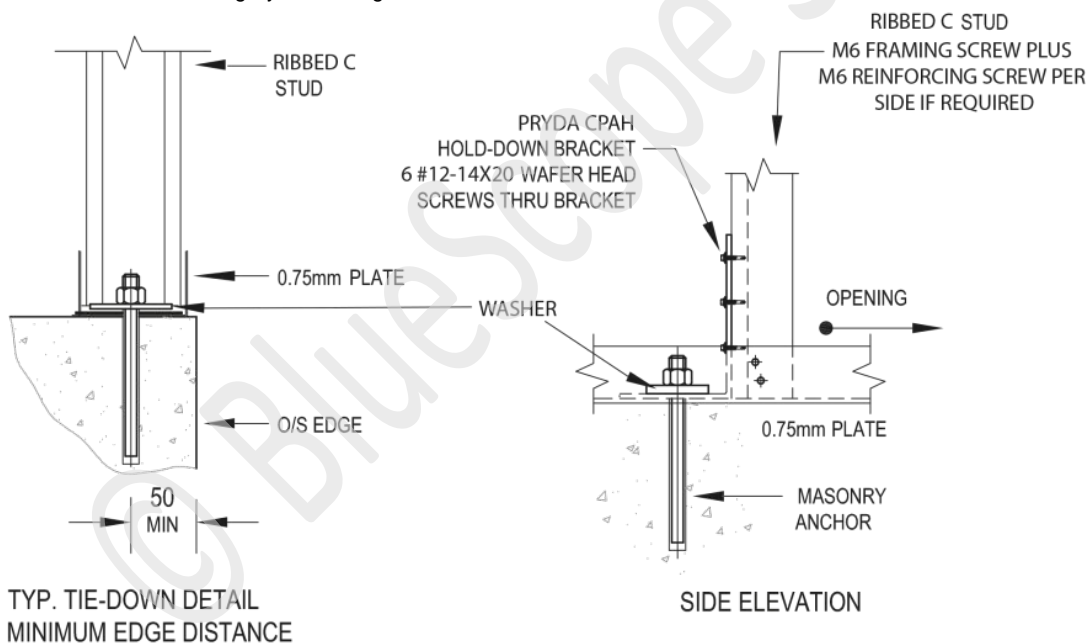

### TYPE C 12 TIE-DOWN - MASONRY ANCHORS WITH BRACKET & WASHER

**Figure 6.8 Tie-down details - Masonry anchors with bracket and washer (high uplift capacity - 12.5kN Limit State)**

For hold down anchor capacity, refer to manufacturer's information.

Suitable hold down anchors are to be provided to resist the uplift forces defined in in Tables 2-5 of Section 3.3.1 of the ENDUROWALL® Building System Design Manual.

**Endurotie® bent tab stud tie down.**

Value 15kN

For hold down anchor capacity, refer to manufacturer's information.

Suitable hold down anchors are to be provided to resist the uplift forces defined in Tables 2-5 of Section 3.3.1 of the ENDUROWALL® Design Manual.



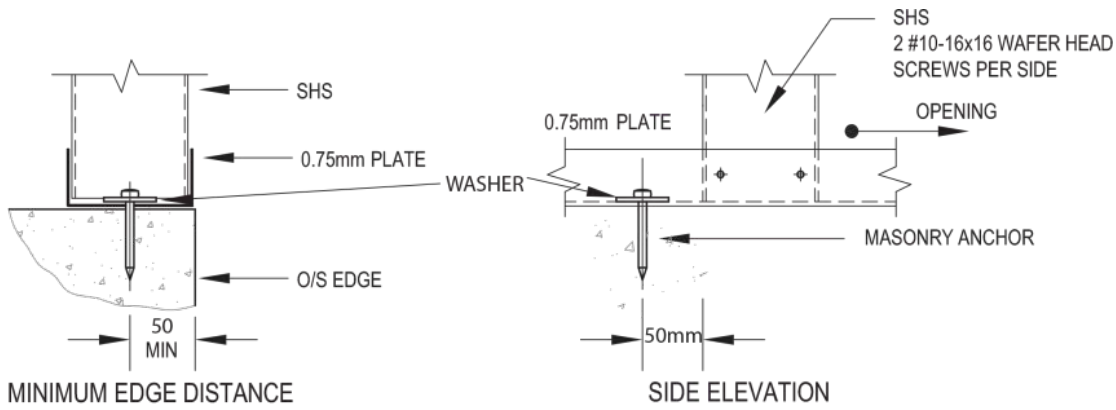

**TIE-DOWN - MASONRY ANCHOR WITH WASHER - LOW UPLIFT CAPACITY**

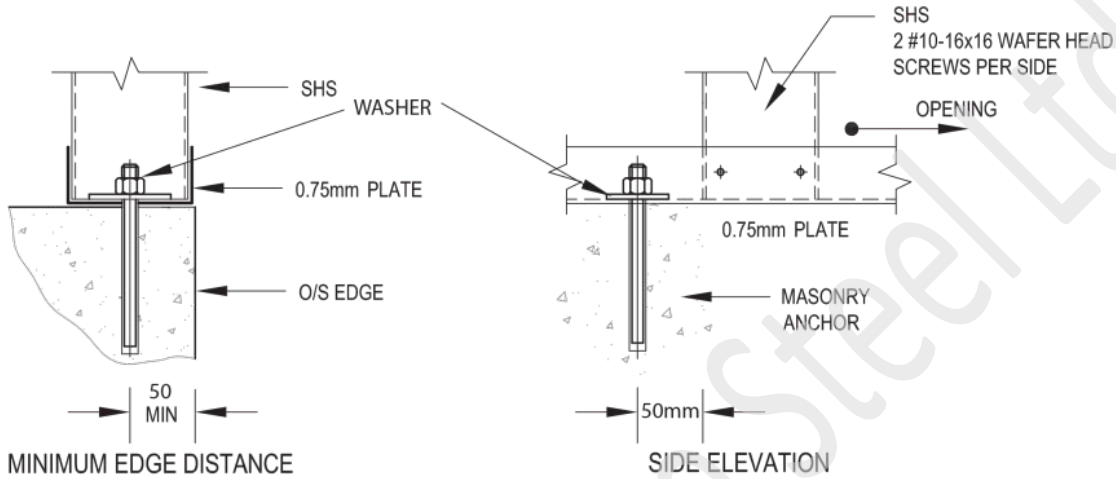

**TIE-DOWN - MASONRY ANCHOR WITH WASHER - MEDIUM UPLIFT CAPACITY**

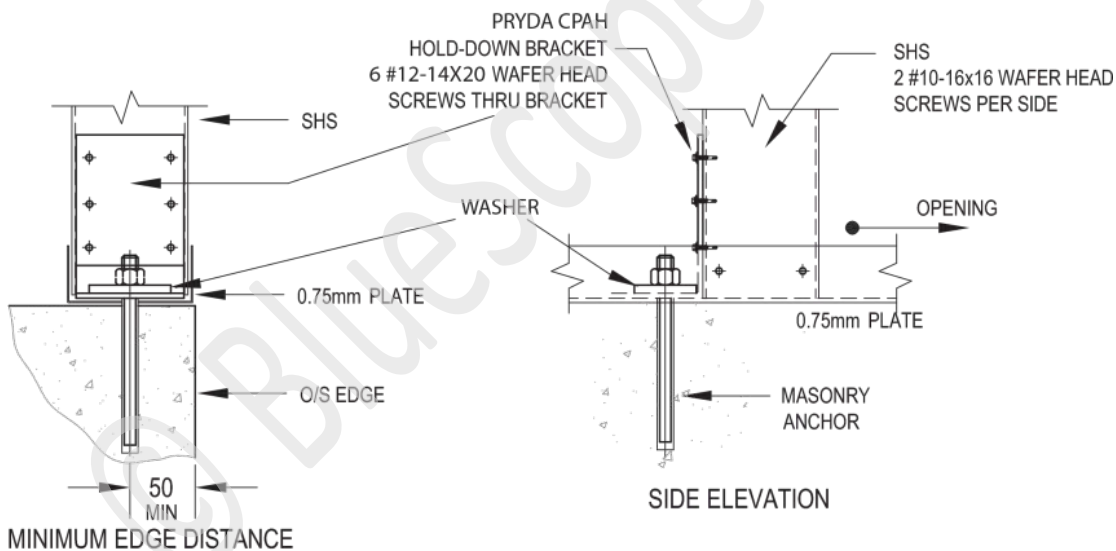

**TIE-DOWN - MASONRY ANCHOR WITH BRACKET & WASHER - HIGH UPLIFT CAPACITY**

**FIGURE 6.9 Tie-down Details - Square Hollow Section (SHS)**

For hold down anchor capacity, refer to manufacturer's information.

Suitable hold down anchors are to be provided to resist the uplift forces defined in in Tables 2-5 of Section 3.3.1 of the ENDUROWALL® Building System Design Manual.

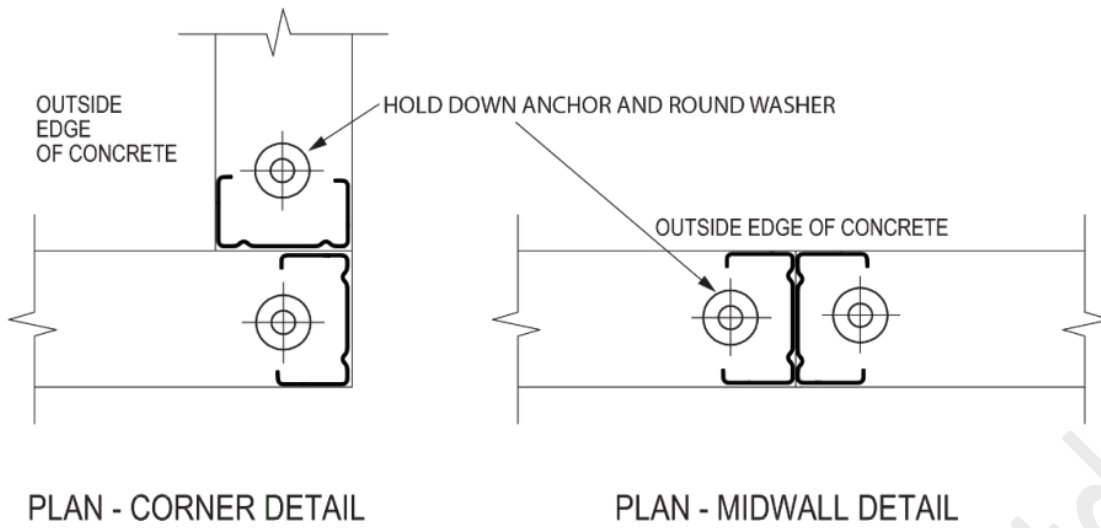

**FIGURE 6.10 - Corner/Mid-wall Detail (Low Uplift Capacity)**

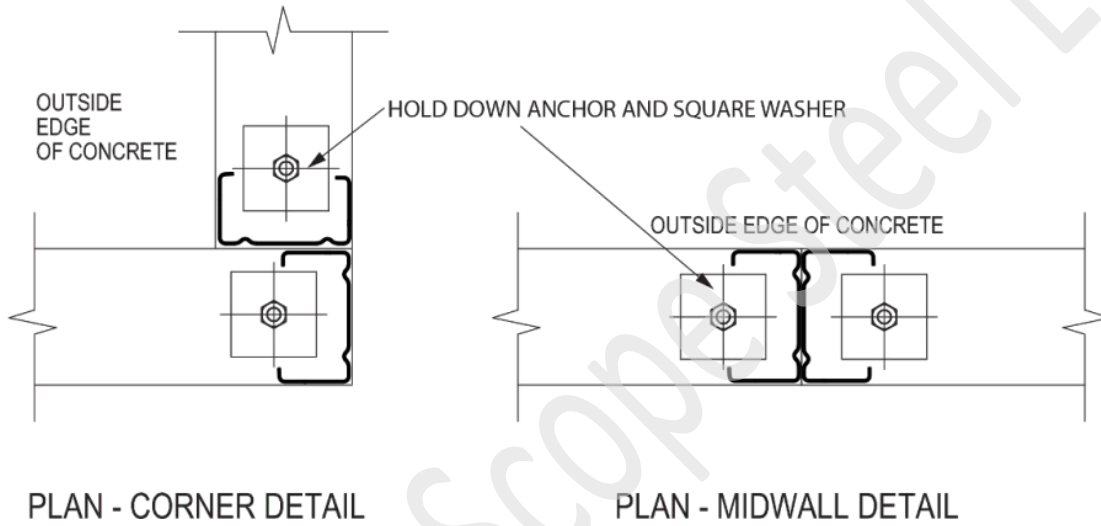

**FIGURE 6.11 - Corner/Mid-wall Detail (Medium Uplift Capacity)**

For hold down anchor capacity, refer to manufacturer's information.

Suitable hold down anchors are to be provided to resist the uplift forces defined in Tables 2-5 of Section 3.3.1 of the ENDUROWALL® Building System Design Manual.

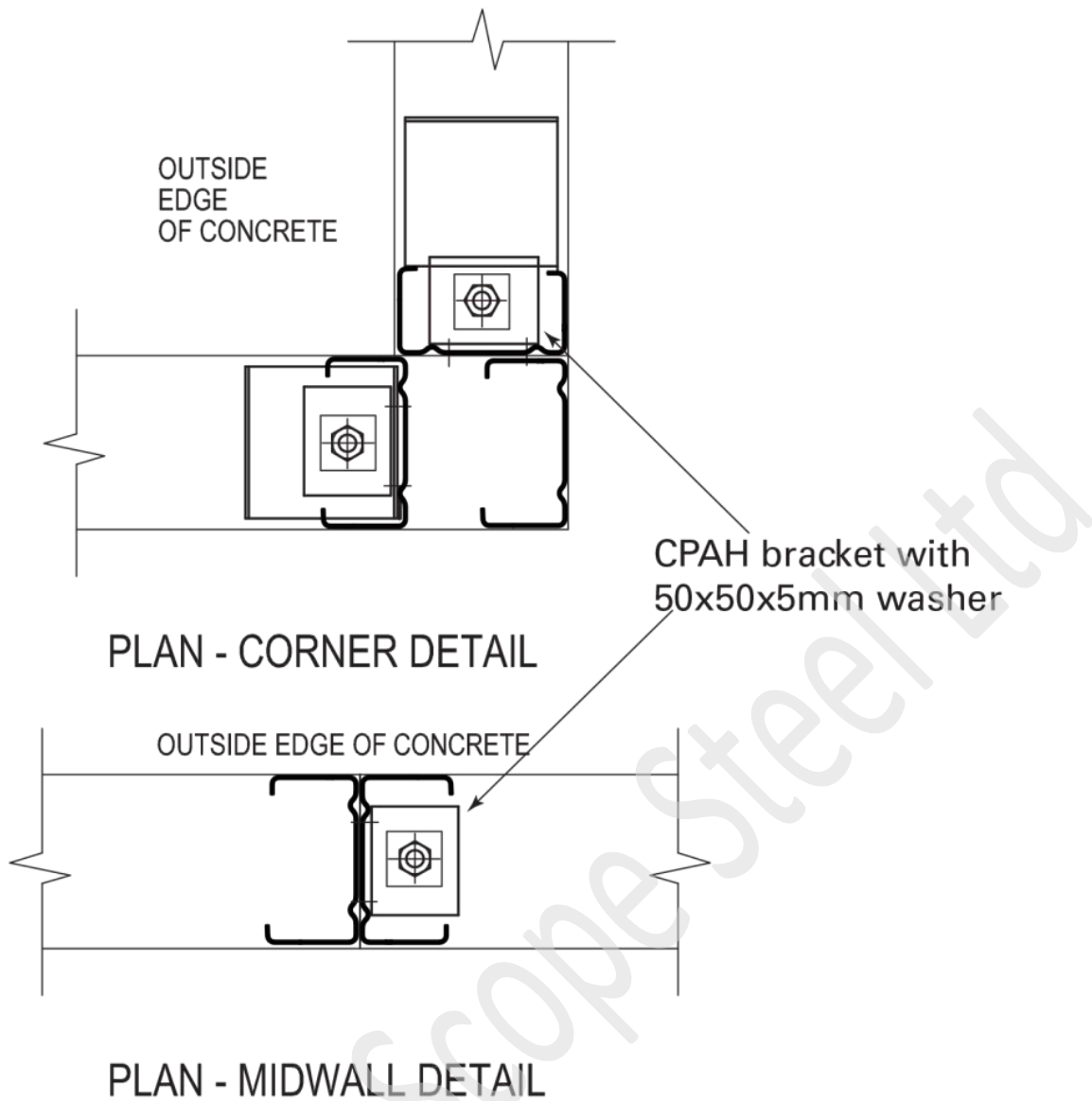

**FIGURE 6.12 - Corner/Mid-wall Detail (High Uplift Capacity)**

For hold down anchor capacity, refer to manufacturer's information.

Suitable hold down anchors are to be provided to resist the uplift forces defined in in Tables 2-5 of the ENDUROWALL<sup>®</sup> Building System Design Manual.

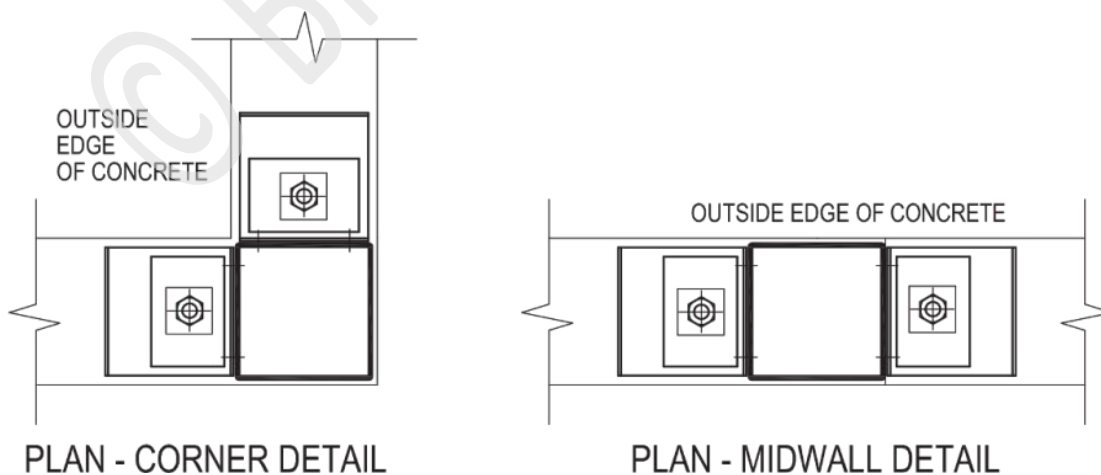

**FIGURE 6.13 - Corner/Mid-wall Detail (SHS)**

For hold down anchor capacity, refer to manufacturer's information.

Suitable hold down anchors are to be provided to resist the uplift forces defined in in Tables 2-5 of Section 3.3.1 of the ENDUROWALL<sup>®</sup> Building System Design Manual.



Base Material	Fasteners Particle Board to Joist	Fasteners Adjacent to Studs	Limit State Load (kN)	Connection Type
<b>Joist Directly under Wall (C20015)</b>	Dia.3.3x5.5mm Duo Fast nails (or equivalent) @ 200mm centre to centre	Dia.3.3x5.5mm Duo Fast nails (or equivalent) @ one nail each side of stud	3.62	<b>A</b>
	Dia.3.3x5.5mm Duo Fast nails (or equivalent) @ 200mm centre to centre	Dia.3.3x5.5mm Duo Fast nails (or equivalent) @ one nail each side of stud	3.88	<b>B</b>
	#10-16x45mm CSK Tek screws or equivalent @150mm c/c	#10-16x45mm CSK Tek screws or equivalent adjacent to each stud	4.76	<b>C</b>
	Dia.3.3x5.5mm Duo Fast nails (or equivalent) @ 200mm centre/centre and Structaflor® adhesive	#12-14x45mm Hex. head Tek screws or equivalent one each side of stud	5.72	<b>D</b>
<b>Hardwood Joist Directly under Wall</b>	X	#12-14x45mm Hex. head Tek screws or equivalent one each side of stud	4.61	<b>E</b>

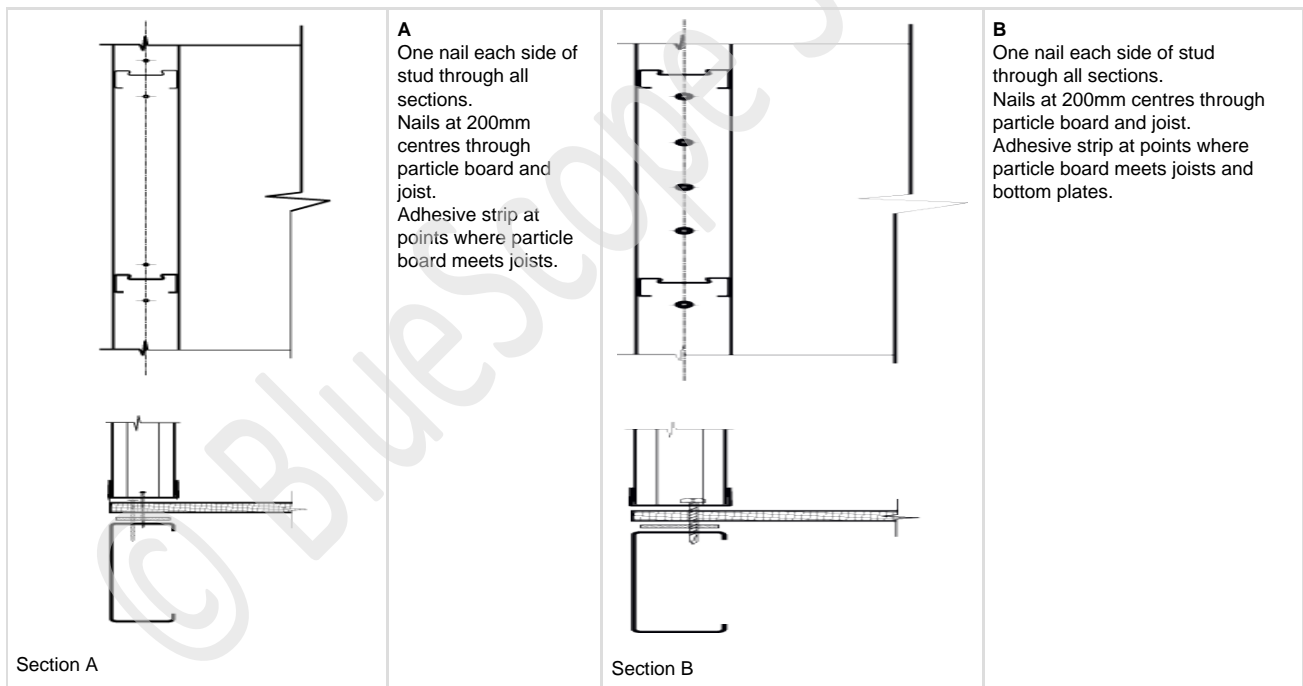

**FIGURE 6.14 - Tie-Down into suspended frame floor systems**

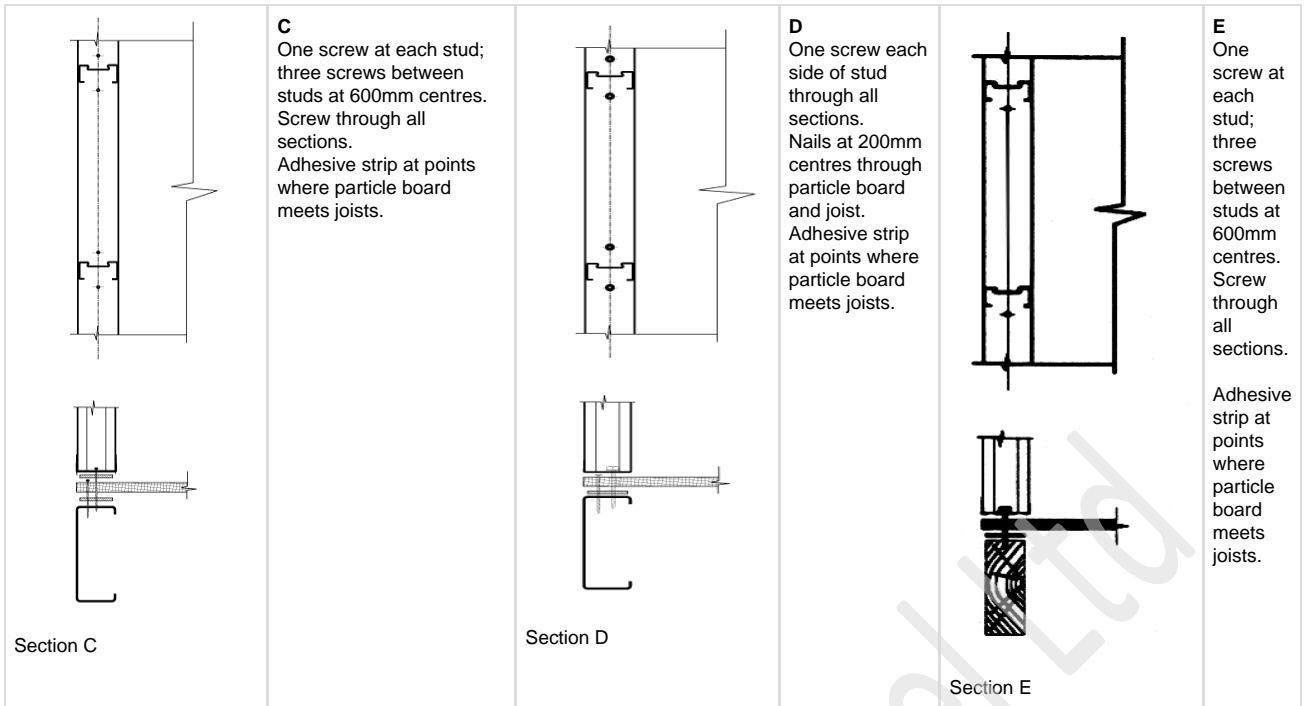
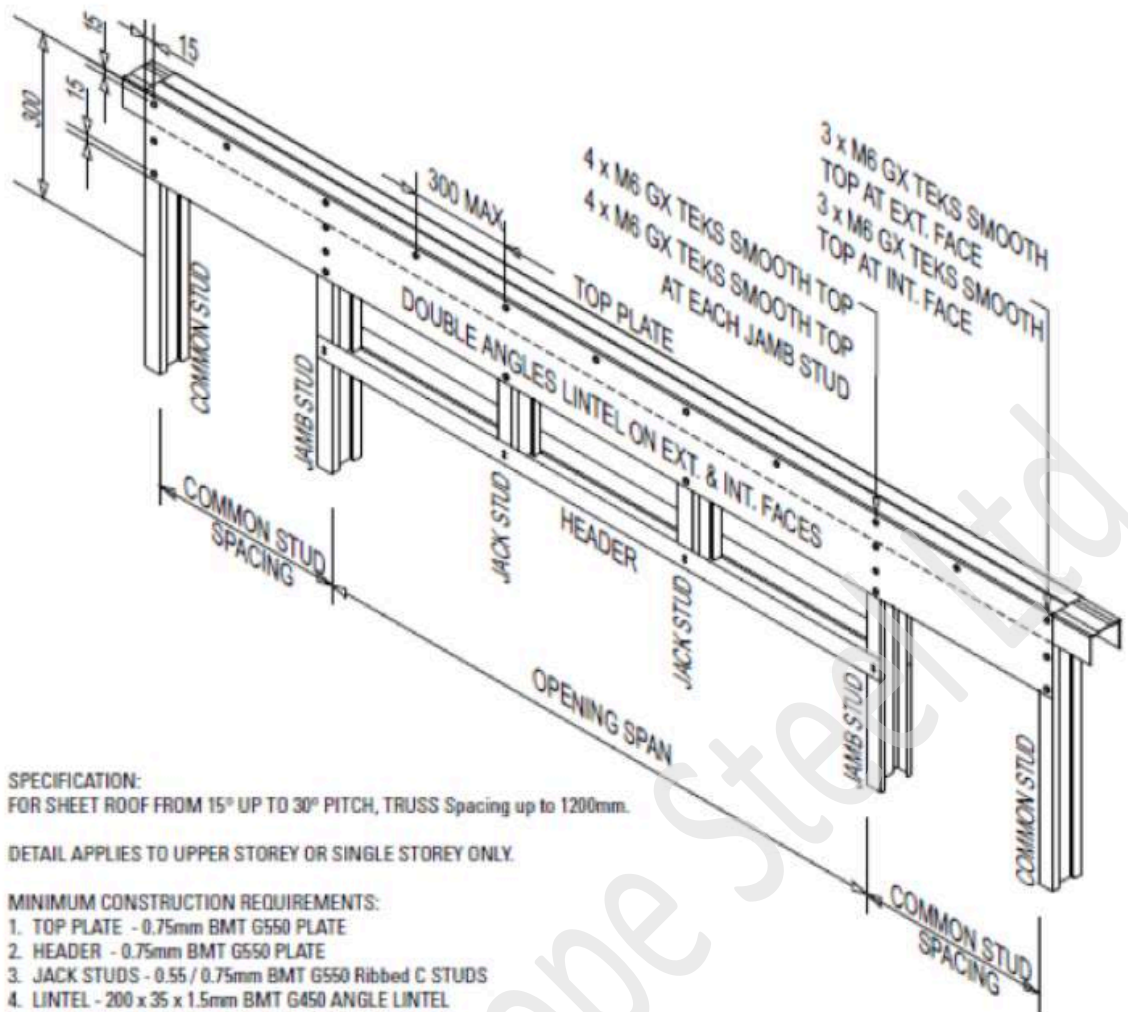

**FIGURE 6.15- Tie-Down into suspended frame floor systems**

**Step 7 - Install lintel flashing (where required)**



Overlay & screw fix lintel flashing to top of frame as per assembly sheet & fixing details given in the Design Manual.



**SPECIFICATION:**  
 FOR SHEET ROOF FROM 15° UP TO 30° PITCH, TRUSS Spacing up to 1200mm.

DETAIL APPLIES TO UPPER STOREY OR SINGLE STOREY ONLY.

**MINIMUM CONSTRUCTION REQUIREMENTS:**

1. TOP PLATE - 0.75mm BMT G550 PLATE
2. HEADER - 0.75mm BMT G550 PLATE
3. JACK STUDS - 0.55 / 0.75mm BMT G550 Ribbed C STUDS
4. LINTEL - 200 x 35 x 1.5mm BMT G450 ANGLE LINTEL
5. JAMB STUDS - 0.75mm BMT G550 RIBBED C STUDS

**NOTE:**

1. JACK STUD AND JAMB STUD MUST BE SECURED TO THE HEADER WITH 1x M6 FRAME SCREW AT EACH CONNECTION, AT EACH SIDE.
2. JACK STUDS MUST BE SECURED TO THE TOP PLATE WITH 1x M6 FRAME SCREW AT EACH CONNECTION ON INTERNAL FACE.
3. SECURE LINTEL TO FRAME AT EXTERNAL FACE WITH M6 GX TEKS SCREW IN POSITION AS SHOWN ON DIAGRAM.
4. SECURE LINTEL TO FRAME AT INTERNAL FACE WITH M6 GX TEKS SCREW IN POSITION AS SHOWN ON DIAGRAM.

**FIGURE 6.16 - Angle lintel fixing details**



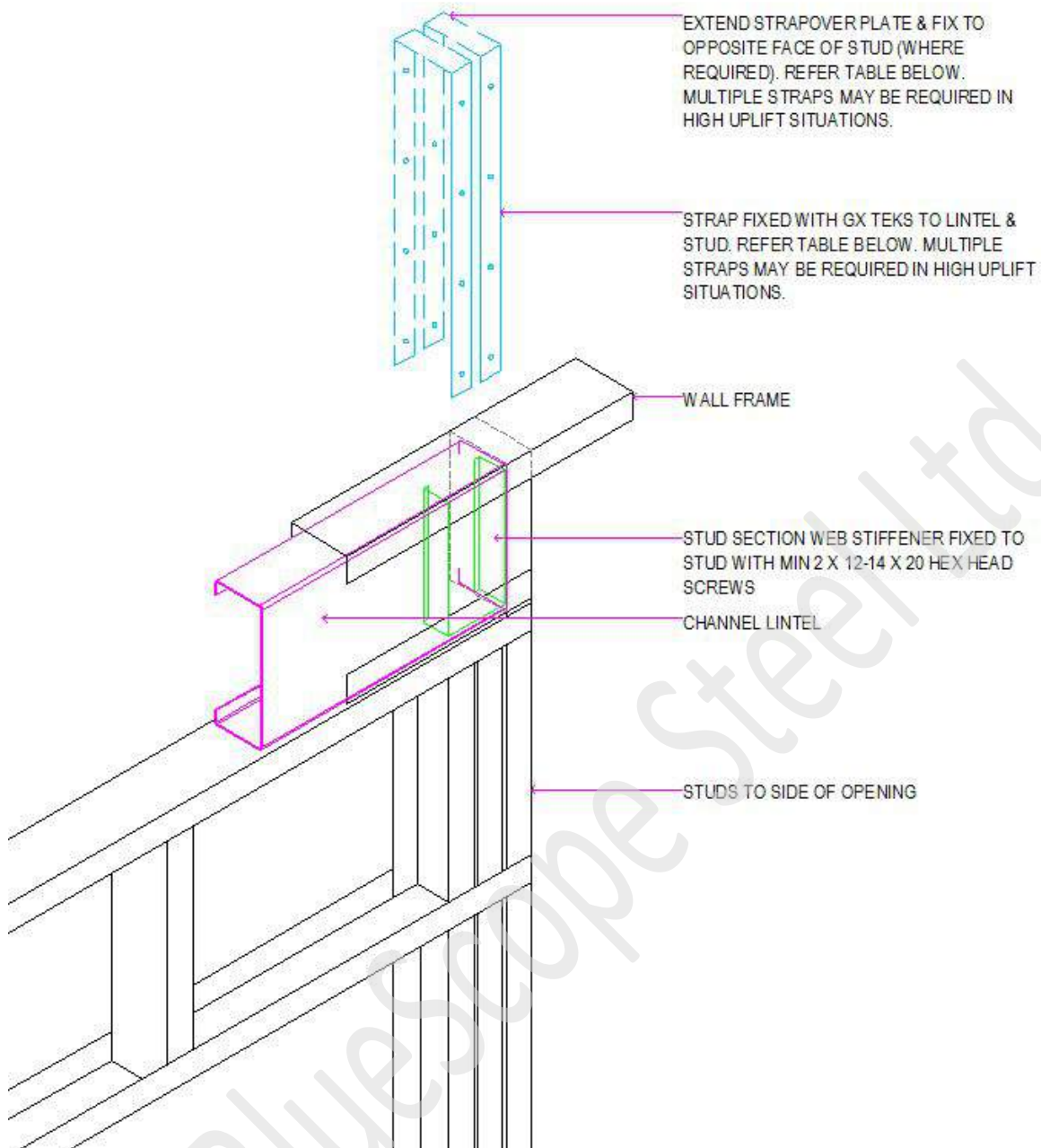

Strap size (G550)	Single (S) or Double(D) sided	No. of Straps	M6 Tek into Header/each strap	M6 Tek into Jamb Stud/ each strap
30x1.0	S	1	2	3
30x1.0	S	2	2	3
50x1.0	S	1	4	6
50x1.0	S	2	4	6
30x1.0	D	1	2	6
30x1.0	D	2	2	6

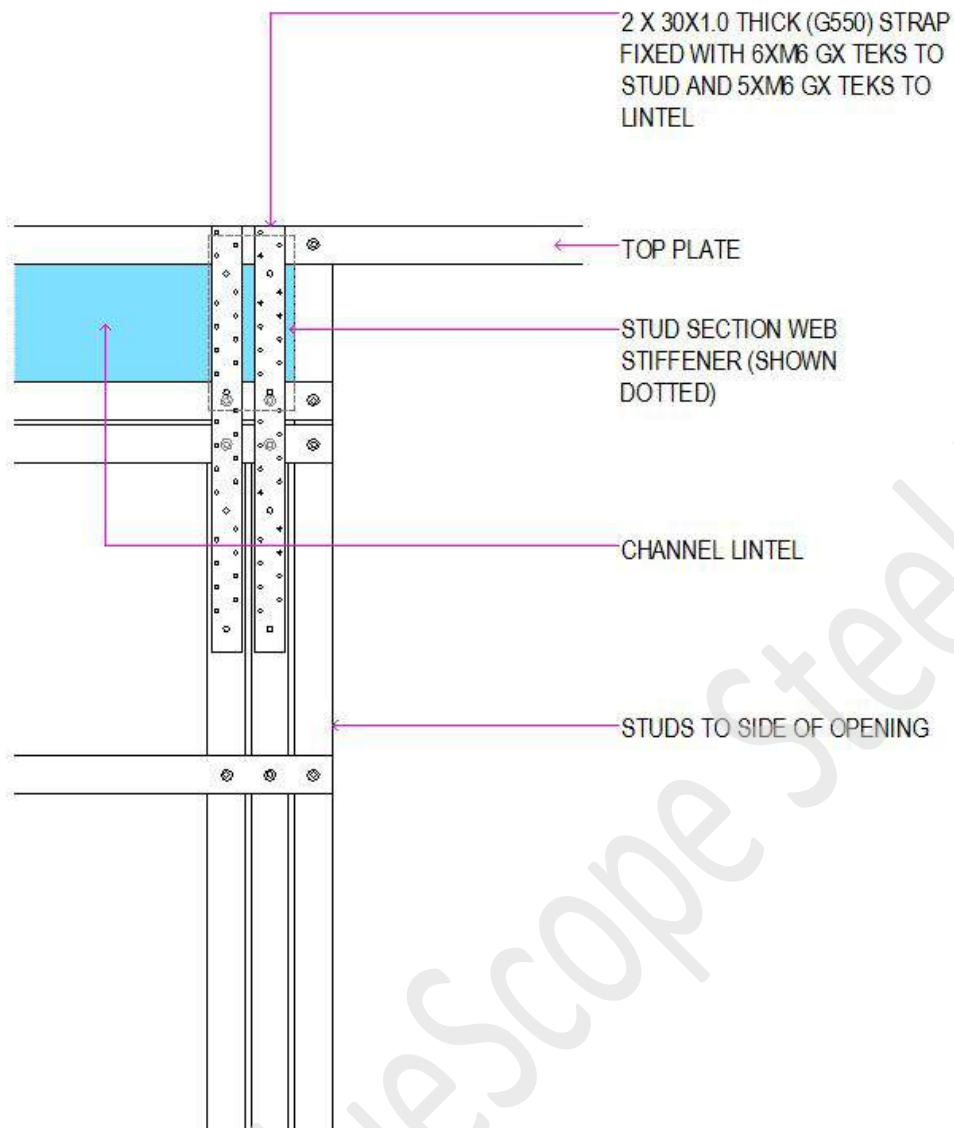

FIGURE 6.17 - Beam Header Fixing Details



Relocate completed frames to a designated stacking area.

**Step 8 Stack completed wall frames before installation**



Completed wall frames to be stacked in a flat area ready for installation.



Stack wall frames in bundles close to the final installation position.





Ensure all wall frame locations have been set out on floor substrate before installation commences. Large wall frames may require additional stiffening to assist stability during installation process.



Always have a "plan of attack" when stacking wall frames. Locate frames in a central location, eliminating unnecessary man-handling & ease of installation.

## 7.0 ENDUROWALL® Wall construction

### 7.1 General & Design

ENDUROWALL® wall frames have been designed to engineering standards and it is essential that to perform as designed, they are handled, erected and braced correctly. The following recommendations apply to wall frames on standard domestic and light commercial buildings.

Components are selected from the ENDUROFRAME® Building System Design Manual and detailed using the ENDUROCADD® design software to suit the specific roof and floor loads appropriate to the site and architecture. Additional loading such as Air Conditioning, etc. require special consideration at the time of design and the placing of these additional loads should be referred back to the designer.

Wind load is an important factor in the design and performance of wall frames. Ensure that the correct design wind loads have been used and that the tie down of frames to the floor structure is carried out in accordance with this manual or as specified by the design engineer.

### 7.1.1 Prior to construction

Before commencing wall construction:

Check the support structure in particular the plan dimensions, the plumb and level of the support structure, the straightness of the supporting walls or beams and that the structure is adequately braced, stable and tied down. Rectify the support structure if found deficient prior to proceeding.

Wall frames must be inspected and any damaged parts must be reported immediately to ensure correct rectification. Approval for site rectification should be obtained from the manufacturer.

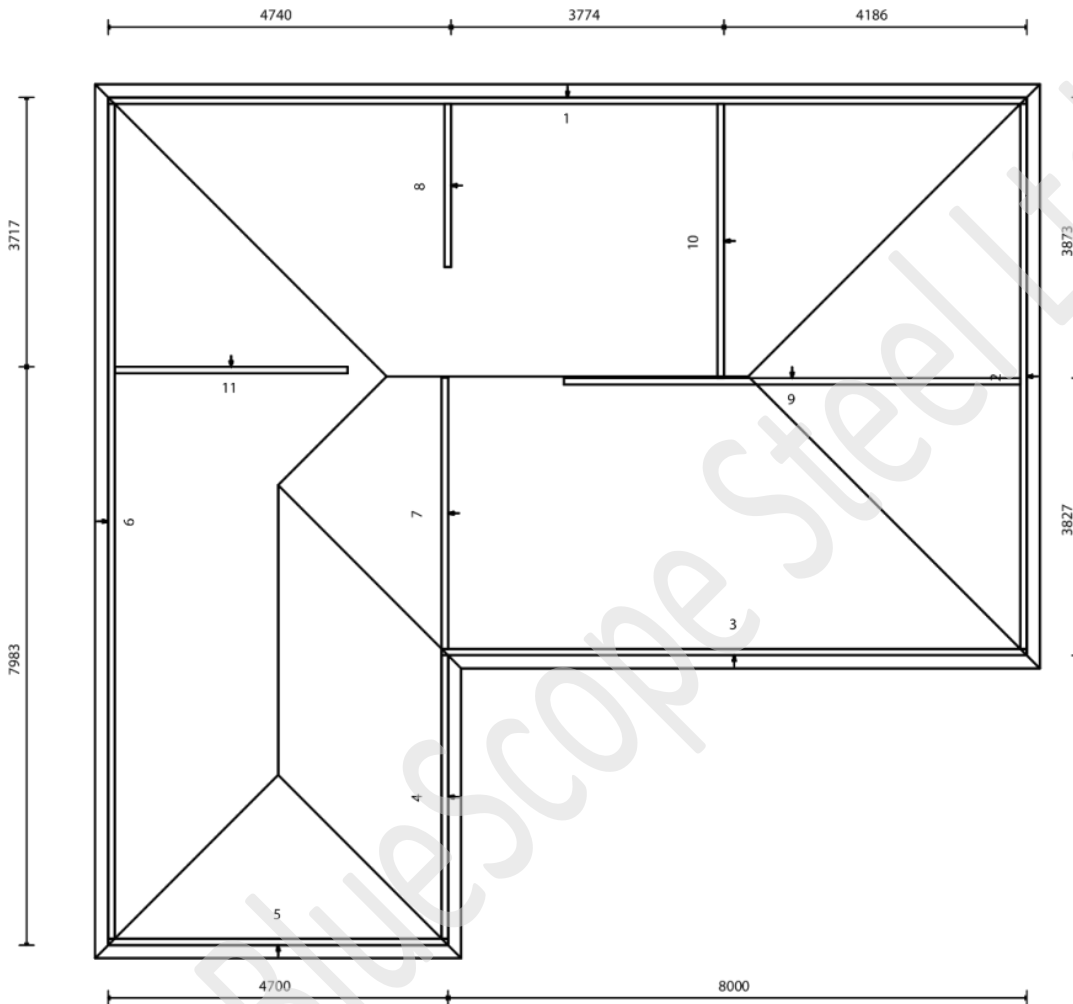

Figure 7.1 Wall frame layout drawing as generated by the ENDUROCADD® software

**NOTES:**

**Frame orientation**The layout drawing specifies the correct frame orientation. Ensure frames are orientated as shown on the wall layout. The branding on the plates and nogging are on the side indicated by the arrows.(Figure 7.1)

**Wall Frame Numbering**During the detailing / fabrication process the wall frames are numbered to accurately identify them. These numbers are shown on the wall frame layout and form part of the frame branding (refer Section 6). In addition location of numbers of incoming walls are marked on the frames. Frames may have identical shape but may differ in the configuration or internal connections. Ensure that the correct frame is used in its specified location on the wall.

### 7.1.2 Safety

Ensure that all barriers or scaffolding used in order to comply with safe work practices are installed so as to not damage or overload wall components.

### 7.1.3 Load bearing wall

The builder should ensure that all loads from both internal and external walls are accommodated in the foundation sub-flooring.

### 7.1.4 Fasteners

Generally, in non-cylonic wall construction, #10-16x16mm wafer or hex head or #12-14x20mm hex head self-drilling Class 3 Tek® screws are used for all structural connections. Use the recommended number shown on the drawings. In connections, maintain a minimum fastener spacing of 17mm and minimum distance of 17mm to the edge of sections.

## 7.2 Wall Frame Setout

Prior to lifting any frames into place, mark out the frame locations on the floor, using the supplied Wall Framing Layout as a reference. Check by measuring diagonals that the marked wall positions are square.



Figure 7.2 Mark set out of wall panels using chalk line

## 7.3 Damp Proof Course

An impermeable membrane should be installed under all perimeter bottom plates fixed to concrete slabs on the ground. The membrane should also extend up the weather side flange of the bottom plate, and may be pre-applied to the bottom plates at the time of rollforming. This is consistent with good building practise and is a condition of BlueScope Steel's warranty on house framing made from TRUECORE® steel. Refer to BlueScope Steel Technical Bulletin-34 from which Figures 1 & 2 below, are taken.



**Figure 1: Deep Edge Rebates**

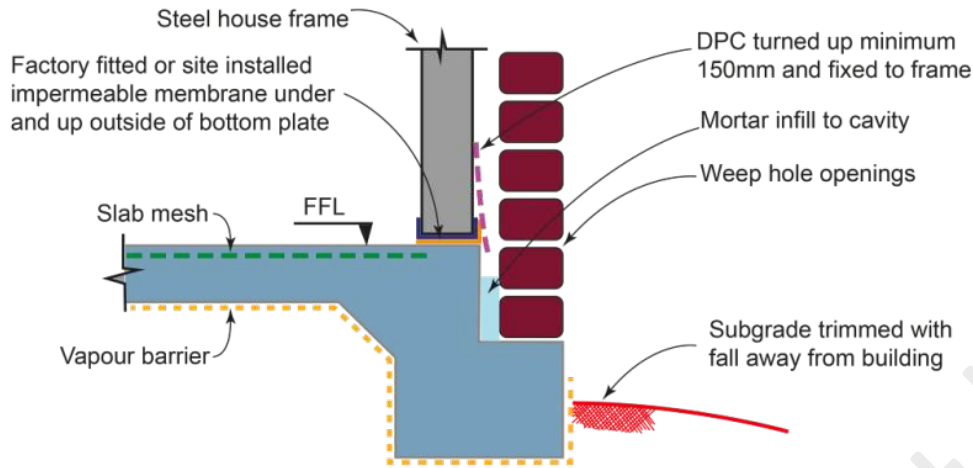

**PROPOSED REBATE SYSTEM**

NOTE: Beam reinforcement shall be designed to suit soil classification.  
 NOTE: Termite management treatments have been omitted for clarity.

**Figure 2: Shallow Edge Rebates**

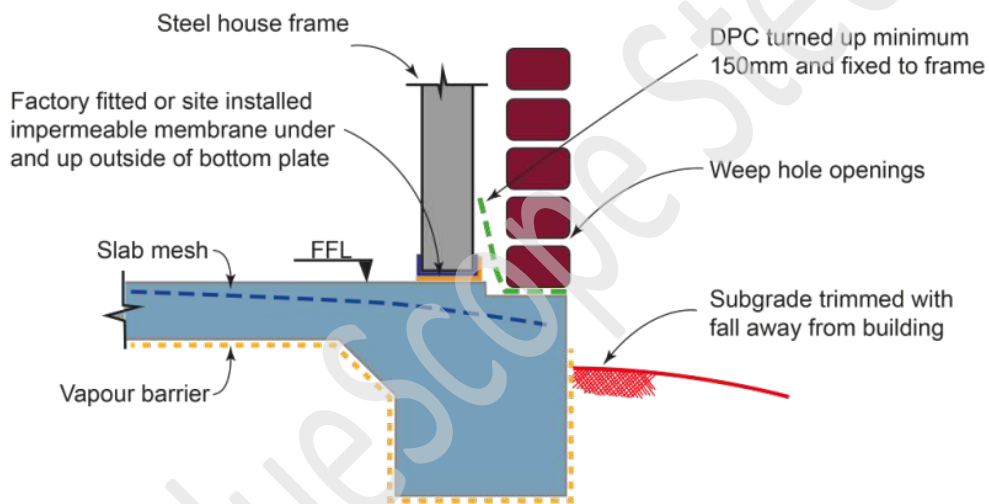

**PROPOSED REBATE SYSTEM**

NOTE: Beam reinforcement shall be designed to suit soil classification.  
 NOTE: Termite management treatments have been omitted for clarity.

When a frame is fixed to a suspended floor, an impervious membrane is not required if adequate ventilation is supplied and a minimum distance of 400mm is allowed between the underside of the floor framing and existing ground level. (The protection of internal bottom plates is not considered necessary. For wet areas refer to Australian Standard AS 3470).

The type of membrane used should be "impermeable to moisture"

Suitable impervious membranes include:

- Bitusik by Grace construction products
- Polyethylene and other products specified in BCA Section: Volume 2, 3.3.4.4
- Brushable Hydroseal from Tremco
- Kordon Termite Barrier (see manufacturer's specification for detail)

The protection of weather side flange is necessary because this part of the frame is subject to moist air movement from the lower parts of the cavity as it tries to evaporate and move past the masonry damp proof course.

Whilst erecting wall frames ensure that each frame is erected in the correct position, correctly orientated: aligned with the wall slopes and plumb (using a spirit level).

Best practice is to use the membrane on all underside surfaces (interior and exterior bottom plates) regardless of conditions.

This ensures moisture control no matter what material the underside of the bottom plates come in contact with.

## 7.4 Wall frame Installation

**Step 1:** Identify each panel location using the ENDUROCADD®-software generated Panel Layout supplied. Unpack the panels and lay them near their required positions to avoid unnecessary handling. (Figure 7.2)

Walls are generally constructed by working across the whole building, not around the perimeter. Doing this avoids trying to fit interior walls after the perimeter is finished. Wall numbers assigned by ENDUROCADD® software help to identify location.



**Figure 7.3 Consult plan layout before starting.**

**Step 2:** Starting from one corner of the building, mark the position of walls on the slab or platform floor using the chalk line. Ensure all lines are square before proceeding. Generally external walls are detailed to maintain 150mm from the outside face of the brick and cavity with 75 mm studs. However, you should check the architectural drawings as this can vary. (Figure 7.3)







**Step 3:** Stand the first wall frame on the location points. (Figure 7.4)

**Step 4:** Stand the next wall section in position and fix it to the first section using #10-16x16 hex. head screws. Complete each junction before proceeding to next panel. Butt joints are made by screwing the adjacent studs at the bottom and mid points, using #10-16x16 hex. head screws. Butt joints are normally only used to connect two walls where there is no junction. (Figures 7.6 & 7.7) Temporary bracing should be used to secure the end of the wall which is not fixed to the second (or subsequent) walls. Use a piece of channel and secure to the wall frame. (Figures 7.8 & 7.9)





Figure 7.5 Place second wall in position using chalk line as a manual and flush against first wall.



Figure 7.6 Fix with a butt joint at corner midway up the wall.



Figure 7.7 Fix using a butt joint at base of wall.



Figure 7.8 Affix temporary bracing as required.





**Figure 7.9 Structure with temporary bracing.**

**Step 5:** Ensure all interior wall panels are erected before completing the perimeter. (Figure 7.10 & 7.11) After all wall panels are erected, move the frames in to the positions indicated by the chalk lines. Ensure rooms are square by measuring and comparing diagonals and fix down using recommended fixings shown in the plan drawings. (Fig.7.12) The fixings are installed next to opening jamb studs, at points where tension bracing attaches to the bottom plate and for trusses with sheet roofs, next to the studs carrying roof loads.

? Unknown Attachment

**Figure 7.10 Place interior walls using chalk lines as manual.**



**Figure 7.11 Interior walls are fixed into position.**





Figure 7.12 Use clamp to hold temporarily in position.



Figure 7.13 End and interior walls are fixed into position.



**Figure 7.14 End wall placed into position and temporarily braced using clamps and/or TOPSPAN battens.**

**Step 6:** Position the final assembled wall frame on the chalk line and remove temporary bracing. Join walls at the corner at bottom and mid-height using the extended drill bit.

**Step 7:** The walls should now be moved into their exact positions using the chalk lines which were drawn on the floor from the layout drawings. Once in position, the walls can be fixed to the floor through the bottom plate of the frame using the hold downs at the spacings specified by the Detailer.



**Figure 7.15 Position final wall.**





Figure 7.16 Remove last of the temporary bracing.



Figure 7.17 Join walls at corner using extension bit.





Figure 7.18 Position and fix final wall using extension bit.



Figure 7.19 Align walls with chalk marks and put into final position before fixing.



**Figure 7.20 Screw bottom plate into final position on floor.**

**Step 8:** Measure diagonals and ensure structure is square.

**Step 9:** Use a spirit level and straight edge to check if the frame is true. Suitable temporary braces should be used to align and plumb long walls until the roof is completed. Plumb the frame by adjusting the bracing tensioners. Tighten one strap and loosen the other to rack the wall until the studs are plumb.

**Step 10:** Fasten the bracing straps at each stud to provide hogging bracing and to prevent rattle within the walls after lining. Ensure #10-16x16 wafer head screws are used where walls are to be lined or clad. On external walls use #10-16x16 hex. head screws in brick veneer construction.

**Step 11:** Where specified on the Panel Layout, additional permanent bracing may require site fitting.





Figure 7.21 Check walls for plumb.





Figure 7.22 Measure lengths at bottom and top of wall to check frame is square.



Figure 7.23 use tensioner on strap bracing to bring the wall into square.



**Figure 7.24 Check plumb and square and adjust as required.**

#### **7.5 Wall Bracing**

The original means of bracing uses diagonal straps of G250/300 material screwed to the frame using #10-16x16 wafer head screws to each end. The bracing is detailed with a tensioner set that enables the site erection crew to tension the strap brace pair on site which can rack the wall enabling the walls to be made plumb (studs vertical in both directions).

Temporary bracing, using TOPSPAN® battens can be used to hold the frame in position while permanent strap bracing is used to adjust the frame for plumb and square.

When the wall is true, the temporary bracing is removed.

**Step 12:** The stud, plate connection requires screw fixing as specified/ designed for specific site conditions.



Figure 7.27 Once the frame is plumb and square, fix at the top of the wall.



Figure 7.26 Use a length of Topspan batten to hold the frame square until bracing can be tensioned.





Figure 7.28 Use strap bracing and tensioner to set frame square and plumb. Note vice grips at mid-span.



Figure 7.29 Wall up, plumbed, squared and fixed - ready to fit roof trusses

## 7.6 Typical non cyclonic hold down connections

The designer should specify the hold down system to be used for each job. Typical wall to floor connections are illustrated below in Figures 7.30 - 7.32.

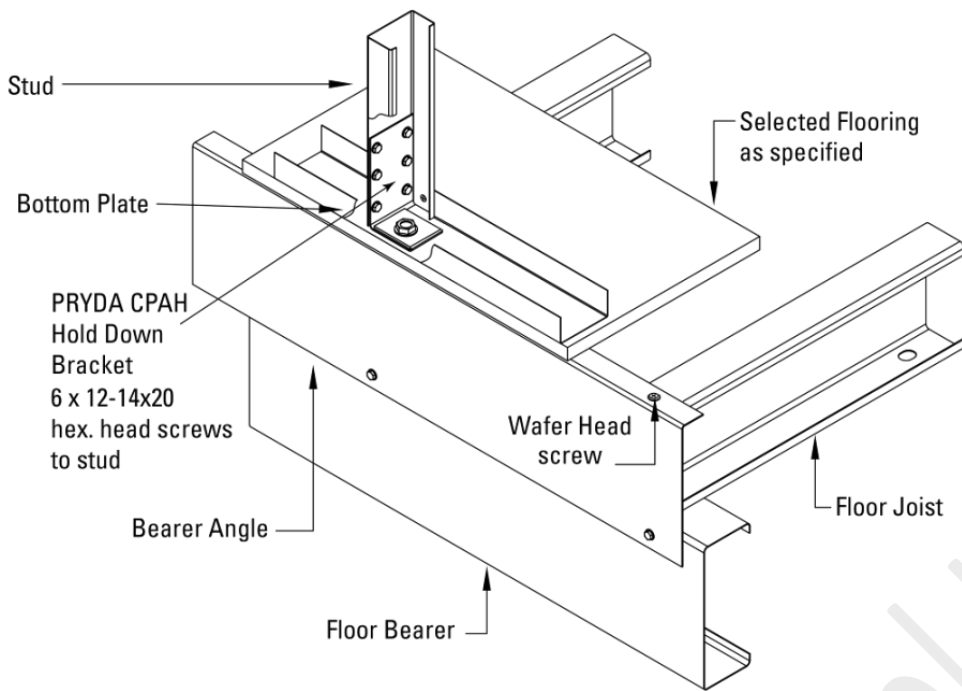

Figure 7.30 Hold down connection Option 1

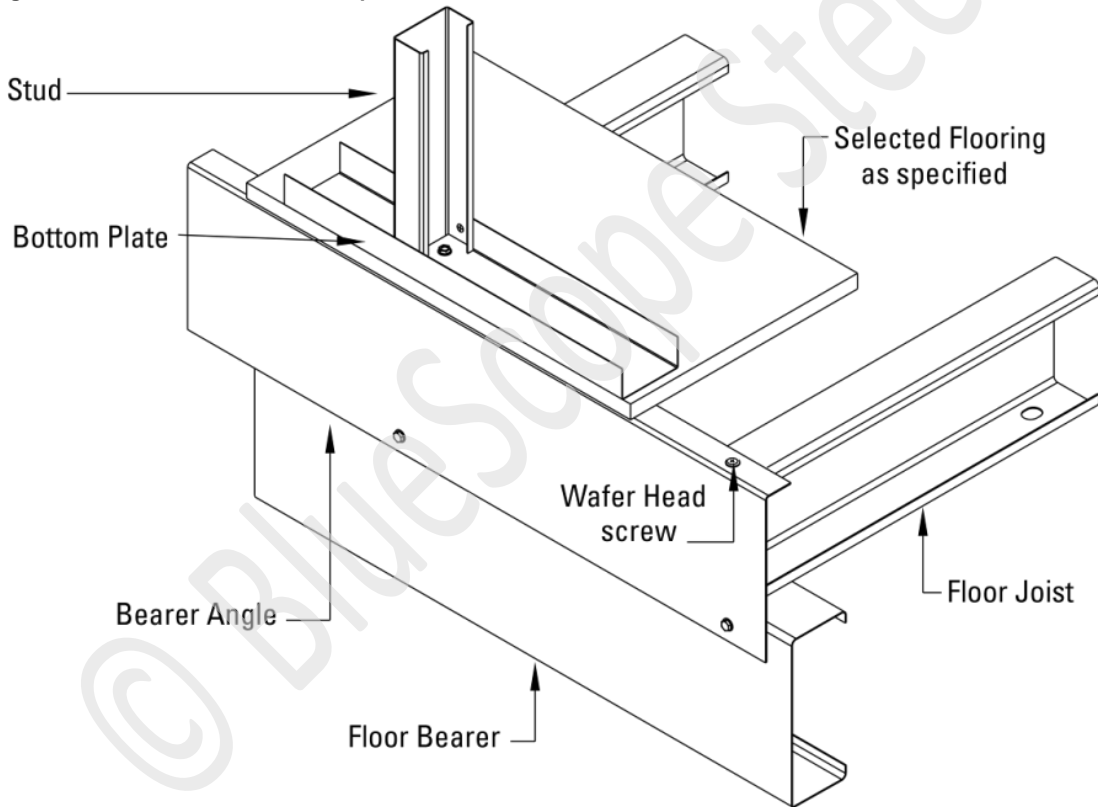
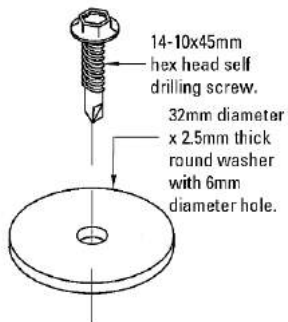

Figure 7.31 Hold down connection Option 2



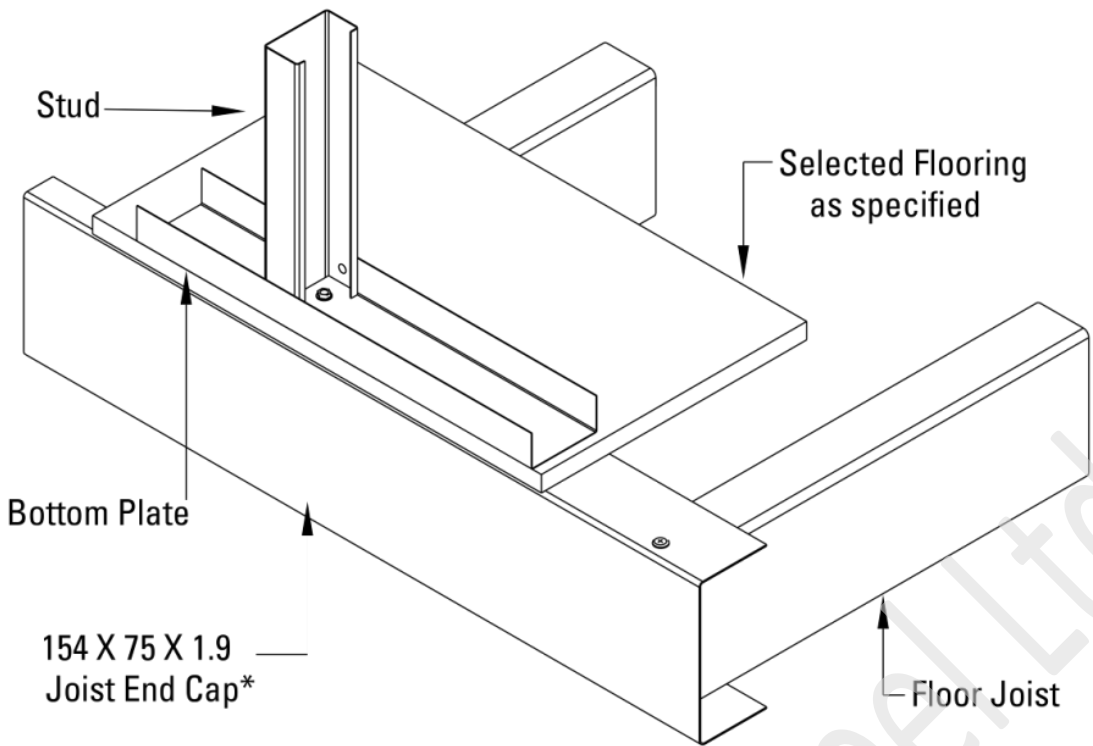

Figure 7.32 Hold down connection Option 3

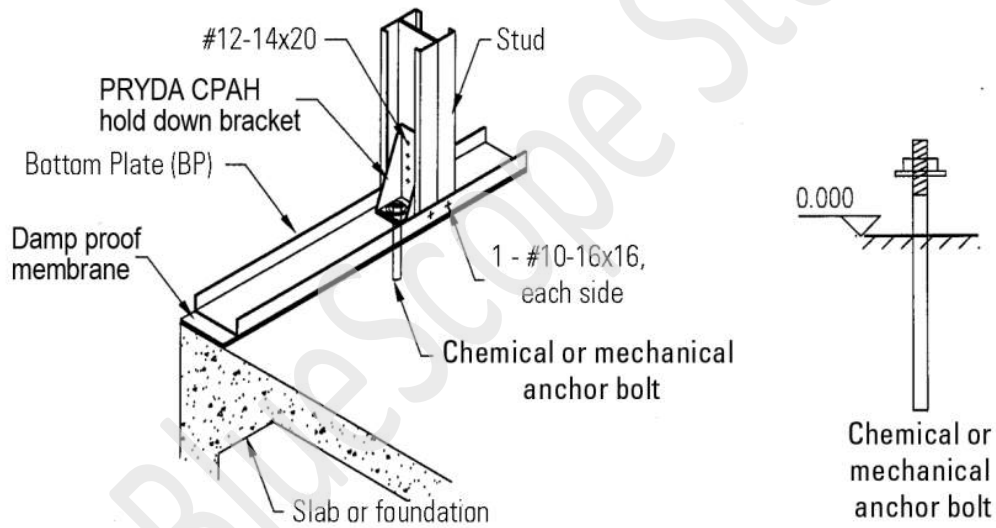

Figure 7.33 Hold down connection Option 4



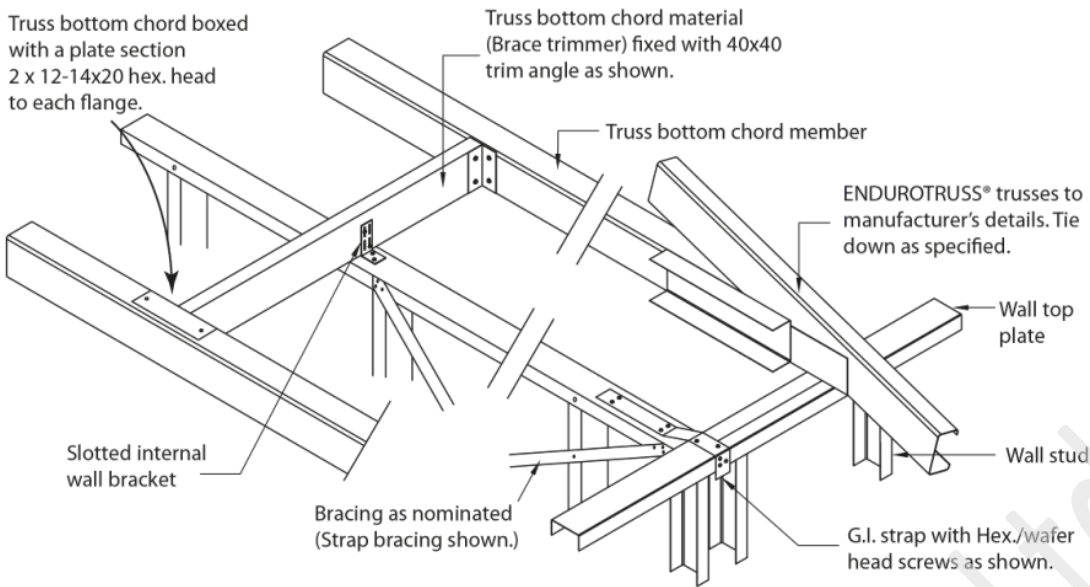

Figure 7.34a - Transfer of Racking Loads to Internal Bracing Walls - Internal Wall Parallel to Trusses

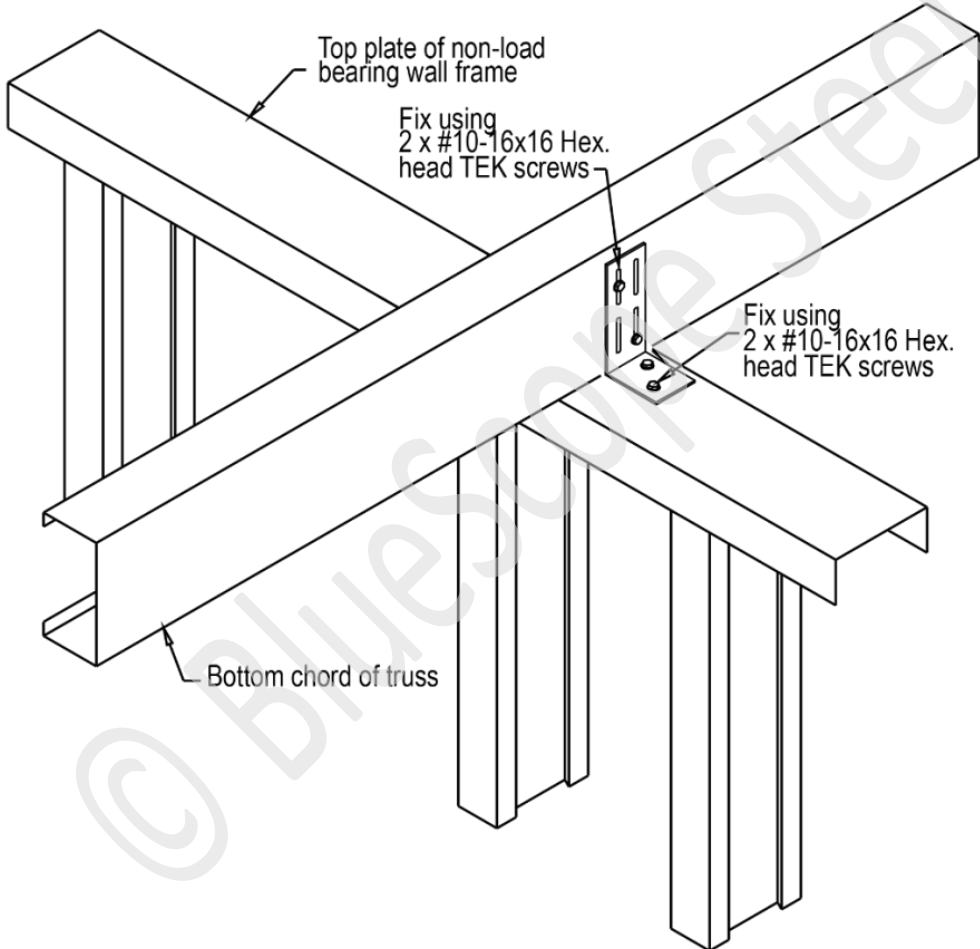

Figure 7.34b - Transfer of Racking Loads to Internal Bracing Walls - Internal Wall Perpendicular to Trusses



**Figure 7.35**  
**Internal to external fixing connections (Option 1)**





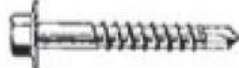

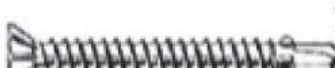

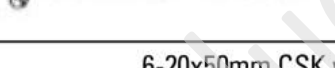

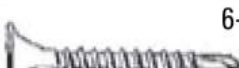

**Figure 7.36**  
**Internal to external fixing connections (Option 2)**

## 7.8 Fasteners

The class of the fasteners should be as stipulated in AS3566.

Fasteners used should be BlueScope Steel approved. The fasteners below are suitable for fixing structural steel frames together, as specified below.

Description	Uses
 10-16x16mm Wafer head self drilling screws	Flush fixing screw where flush surface finish is required, e.g. Plasterboard® corner angles. Connecting framing sections.
 10-16x16mm hex. head Self drilling screw	General non-structural fixing screw. Uses: wall connectors, roof battens etc.
 12-14x20mm hex. head self drilling screw	Structural fixing screw, tiles roof truss fixing, girder/truss heel bracket fixing, roof battens.
 M6x1Px15mm Smooth Top Frame Screw	Used to fabricate wall panels.
 M6x1Px22mm Smooth Top GX Teks Frame Screw	Used as a reinforcing screw.
 12-14x45mm hex. head self drilling screw	Fixing wall bottom plate to steel joints.
 12-24x32mm Hex series 500 hex. head self drilling screw	Used for fixing steel brackets or joists to heavy gauge beams up to 12mm thickness.
 10-24x75mm CSK wing self drilling screw	For fixing timber batten or timber to steel. Timber thickness range 25-30mm.
 10-16x45mm CSK self drilling screw	Timber floor to steel joists fixing. General timber to steel. Timber thickness range 30mm.
 8-18x35mm SEH wing self drilling screw	Used on Hardiplank®. Weathertex® and assorted timber claddings to steel stud work. (Use stainless steel for cedar).
 6-20x50mm CSK wing self drilling screws	Architraves, reveals and skirtings. General finishing and fixing timber screw.
 6-20x65mm CSK self drilling screws	Architraves, reveals and skirtings. General finishing and fixing timber screw.
 6-18x30mm bugle needle point self drilling screws	Plasterboard fixing to ceiling battens.
 6-20x25mm bugle drill point self drilling screws	Plasterboard fixing to wall frame studs.

Product	Base Metal Thickness (mm)	Grade of Steel	Coating
Angle Lintel 200 x 35 mm	1.0	G550	AZ150
	1.5	G450	AZ150/ Z275
Angle Trim 35 x 35	0.75	G550	AZ150
	1.00	G550	AZ150



Bath Rail	<b>Bath Rail</b> An additional structural member of a wall panel set into studs to provide a recess for a bath. Bath rails are usually factory-fitted but may be supplied loose.		
Shower Rail	<b>Shower Rail</b> An additional structural member of a wall panel that is set into the bottom of studs to provide a recess for a shower tray. A shower rail is usually factory-fitted but may be supplied loose.		
<b>Accessory</b>	<b>Material</b>		
Electrical Grommet 28mm	Nylon 6 - Black		
Plumbing Grommet 28mm	Nylon 6 - Black		

© BlueScope Steel Ltd

**Profile**

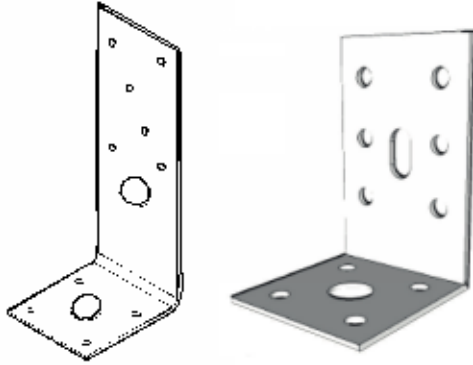

**Accessory**

Pryda CPAH Hold-down Bracket)

Modified CPAH bracket

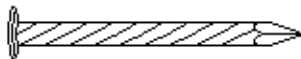

Duofast Nail or equivalent

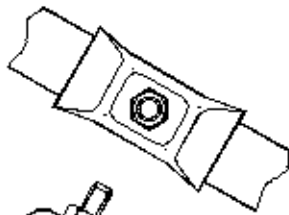

Brace Tensioner Set

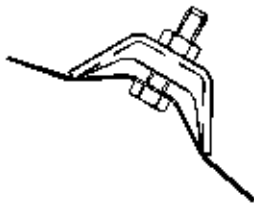

Internal Wall Bracket

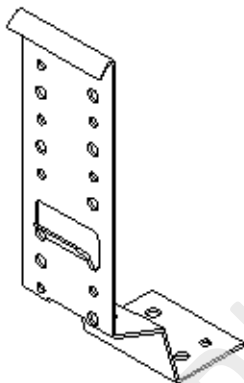

Pryda Hitch

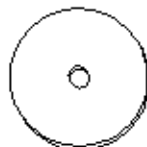
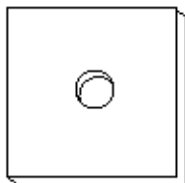
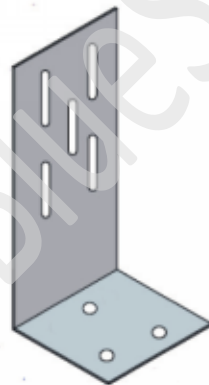

Square washer/  
Round washer

## 8.0 References

AS4055: 2006 Wind Loads for Housing

AS4440: 2004 Installation of nail plated timber wall trusses

AS3566.1: 2002 Self-drilling screws for the building and construction industries

NASH Handbook Low Steel Framing, National Association of Steel Framed Housing 2008

NASH Standard - Residential and Low Rise Steel Framing: Part 1, Design Criteria, National Association of Steel Framed Housing 2005  
AS1397:2011 Steel sheet and strip - Hot-dipped zinc-coated or aluminium/zinc-coated - Continuous hot-dip metallic coated steel sheet and strip - Coatings of aluminium, zinc and magnesium

© BlueScope Steel Ltd