

ENDURO FRAME[®]



ENDUROTRUSS[®] System Installation Manual

Find the latest version at <https://enduroframe.atlassian.net/wiki/display/IM/>

© BlueScope Steel Ltd.

ENDUROTRUSS® Roofing System Installation Manual

- General notes to be read before you use this manual:
 - Important disclaimer about this construction manual
 - ENDUROCADD® software package
- 1.0 Scope of manual
 - ENDUROTRUSS® Product performance
- 2.0 On-site handling
 - 2.1 Slings
 - 2.2 Roof trusses exposure and storage
- 3.0 Tools & equipment
- 4.0 Points for construction
- 5.0 Truss identification
- 6.0 Truss Assembly
 - 6.1 ENDUROTRUSS® Framing System marking and branding
 - 6.2 Chord to chord connection identification
 - 6.3 Fasteners
 - 6.4 ENDUROTRUSS® Framing System assembly
 - 6.4 ENDUROTRUSS® splicing
 - 6.5 ENDUROTRUSS® Framing System stiffening and re-inforcement
 - 6.5.1 Web stiffening
 - 6.5.2 Apex stiffening
 - 6.5.3 Heel Stiffening
 - 6.5.4 Knee Stiffening
 - 6.5.5 Web Stiffening
 - 6.5.6 Chord Boxing
 - 6.5.7 Web Boxing
- 7.0 Roof construction
 - 7.1 General and design
 - 7.1.1 Prior to construction
 - 7.1.2 Internal load bearing
 - 7.1.3 Fasteners
 - 7.2 Roof truss set-out
 - 7.3 Gable End Construction
 - 7.4 Hip End Construction
 - 7.4.1 Type 1 Hip construction
 - 7.4.2 Type 1A Hip construction
 - 7.4.3 Type 2 Hip Construction
 - 7.5 Dutch gable construction
 - 7.6 Valley end construction
 - 7.6.1 Girder-bridge truss connection
 - 7.6.2 Saddle truss construction
 - 7.6.3 Radial Roof
 - 7.7 Common roof block construction
 - 7.8 Truss and Rafter Tie Down Connections
 - 7.8.1 Boxed Tie Downs
 - 7.9 Roof bracing
 - 7.9.1 Temporary bracing
 - 7.9.2.1 Cross Brace
 - 7.9.2.3 Bracing Layout
 - 7.9.3 Bottom chord bracing
 - 7.9.4 Web bracing
 - 7.10 Battens
 - 7.10.1 Ceiling battens and plasterboard angles
 - 7.10.2 Internal wall support and shear transfer
 - 7.10.3 Roof battens and spacings
 - 7.11 Fasteners
- 8.0 Definitions of terms
- 9.0 References



ENDUROTRUSS-InstallationManual-100616



The smart, simple solution to roof framing.

General notes to be read before you use this manual:

1. This Manual has been prepared for a range of roof framing designs using ENDUROTRUSS® building components manufactured or supplied by BlueScope Steel, its licensed manufacturers or dealers.
2. The ENDUROFRAME® Building System has been designed as a complete framing system.
3. All erection and connection details must be made in accordance with the relevant standard connection drawing details contained in this Manual or its supplements, or drawings output from the ENDUROCADD® software.
4. Before commencement of any fabrication or construction develop a safety management plan to cover key risks. Key risks include, but are not limited to:-
 - a. Working at heights
 - b. Electrical safety
 - c. Cuts and scratches
5. Consider and install the appropriate level of safety equipment to manage identified risks. Safety equipment that may be required includes:-
 - a. Personal protective equipment including safety glasses, gloves, hearing protection (when using power tools) and sunscreen;
 - b. Appropriate fall protection equipment including guard rails, scaffolds, ladders, elevated platforms, safety mesh, and fall restraint harnesses
6. A temporary earth should be established during the construction of steel frames and, upon completion, the steel house frames must be permanently earthed in accordance with the requirements of local electricity authorities.
7. You should check with your local workplace health and safety authority to see what safety measures you need to put in place prior to and during construction. It is the responsibility of the installer/erector to ensure all local safe work practices are adhered to and the safety of the whole site is maintained at all times.
8. For wiring in steel wall frames, nylon grommets shall be installed to run electrical cables through.
9. Where insufficient detail is included in this manual for your project, seek specialist advice.
10. Before you commence construction:
 - a. You should check with your local government authority to see if any form of prior permission or approval is required;
 - b. If you want to build or construct any attached structure, you should seek advice from a suitably qualified engineer to verify the capacity of your existing structure to withstand any additional load arising from the attached structure. You should also check with your local government authority to determine any specific requirements for the attachment to existing structures;
 - c. You should check with your local workplace health and safety authority to see what safety measures you need to put in place prior to and during construction. It is the responsibility of the installer/erector to ensure all local safe work practices are adhered to and the safety of the whole site is maintained at all times.
 - d. Contact info@enduroframe.com.au.
11. Refer to www.truecore.com.au for locations where the ENDUROFRAME® Building System can be warranted.

Important disclaimer about this construction manual

Date of Issue

This Manual was issued on September, 2014. BlueScope Steel may make changes to this Manual in its sole discretion. You should check you are using the current version of the Manual before you start construction. Refer to www.enduroframe.com to check version.

Conditions of Use

If you use this Manual, you acknowledge and agree that your use is subject to the terms and conditions in this Manual. BlueScope Steel, its agents, officers, employees, subcontractors or consultants make no representations, either expressed or implied, as to the suitability of the information and data in this Manual for your particular purposes. It's your responsibility to ensure the design you use is appropriate for your needs, the products you have purchased, your site and structural limitations and your building and construction capabilities. It is recommended that you obtain qualified expert advice.

Use of Genuine Materials

Structures in this Manual must only be built or constructed using those genuine ENDUROTRUSS® building components made from TRUECORE® steel and made with the ENDURO® rollformer or recommended third party products. Except as otherwise provided in these terms, any warranties only apply to you (if at all) if you use the genuine BlueScope Steel or recommended third party products and method of construction.

Check Delivery

It is important that you check all materials delivered to site against your invoice before you use them in your building or construction to ensure all components have arrived, are of the appropriate quality and are ready for installation.

Limitation of Liability

By using this Manual, you accept the risks and responsibility for all losses, damages, costs and other consequences resulting directly or indirectly from using this Manual. Except to the extent to which liability may not lawfully be excluded or limited, BlueScope Steel will not be under or incur any liability to any person for any direct or indirect loss or damage (including, without limitation, consequential loss or damage such as loss of profit or anticipated profit, loss of use, damage to goodwill and loss due to delay) however caused (including, without limitation, breach of contract, negligence, breach of statute and/or in equity), which may be suffered or incurred in connection with this Manual.

All rights reserved. No part of this brochure may be reproduced, stored in a retrieval system, or transmitted in any form or by any means, electronic, mechanical, recording or otherwise, without written permission of BlueScope Steel Limited. ABN 16 000 011 058.

ENDUROCADD® software package

The ENDUROTRUSS® framing system uses the ENDUROCADD® software as a purpose-built roof design package. The ENDUROCADD® software lays out all roof truss members and conducts a structural analysis on all truss members. Only trusses that have been passed by the ENDUROCADD® software in the certification sheets should be used in construction.

The ENDUROCADD® software generates all numeric control data which exported to ENDURO® rollformers which manufacture all of the parts including punching location holes, notching sections, and inkjet marking part numbers. A selection of outputs from the ENDUROCADD® software is shown below.



© Bluescope Steel Ltd

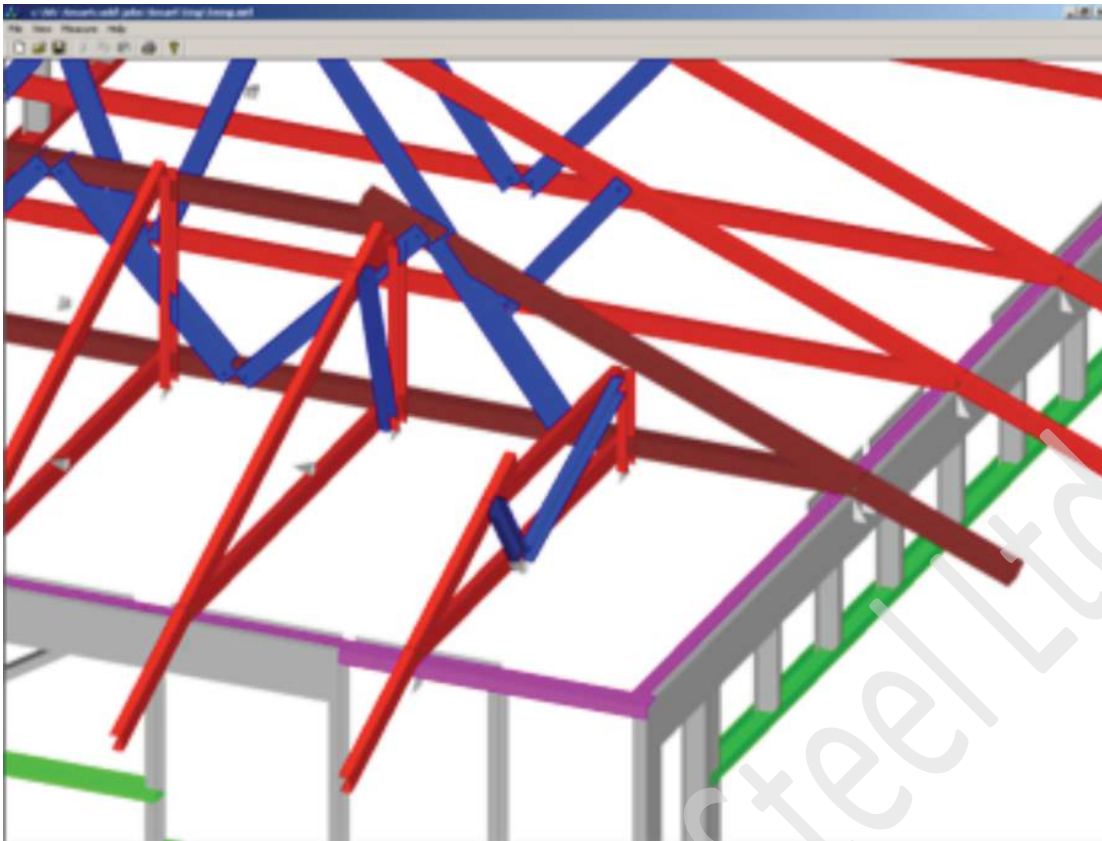

Sample screens showing truss layout. Drawings can be enlarged to show fine detail

smart: YES flush: YES LEFT ← RIGHT

ANALYSIS QTY
Status PASS 2
Approved BY

Channel truss, Span = 9230

PARTS LIST (per truss)				ASSEMBLY DETAILS			TRUSS DETAILS								
DESCRIPTION	NO.	LEN	MAT	QTY	DESCRIPTION	NO.	LEN	MAT	QTY	APEX HEIGHT	LEFT PITCH	RIGHT PITCH	UNROOFED LENGTH	UNROOFED HEIGHT	WEIGHT
CR075A	001	9230	075	1	CR075A	003	923	075	1	2228	L=25	R=25	9530	2304	36
CR075A	002	3059	075	1	SCREW T2 14x20 HEX				21						
CR075A	003	305	075	1	WASHER				1						
CR075A	004	1098	075	1					1						
CR075A	005	850	075	1					1						
CR075A	006	1930	075	1					1						
CR075A	007	1690	075	1					1						
CR075A	008	3050	075	1					1						
CR075A	009	3050	075	1					1						
CR075A	010	1600	075	1					1						
CR075A	011	1500	075	1					1						

FABRICATOR:		BlueScope Steel Ltd	
CUSTOMER:		ATEC	
JOB NUMBER:		ATEC T011	

Page 1 of 1

Truss sheet with bill of materials makes construction easy on-site

1.0 Scope of manual

This manual has been prepared for the construction of a trussed roof within the following parameters:

- Only ENDUROTRUSS® Framing System components made from TRUECORE® steel and made with the ENDURO®

- rollformer can be used
- Erection details cover construction for cyclonic and non-cyclonic buildings. (See Table below.)
- Other spacings may require additional engineering
- Trusses suitable for both sheet roof cladding and tiled construction.

This installation manual covers the installation according to the following wind classifications, roof types and truss spans.

Table 1 - Wind categories covered by this installation manual

Wind Classification	Truss Spacing	N1	N2	N3	C1	C2	C3	C4
Tiled Roof	600mm	Y	Y	Y	N	N	N	N
	900mm	Y	Y	Y	N	N	N	N
	1200mm	Y	Y	Y	N	N	N	N
Sheet Roof	600mm	Y	Y	Y	Y	Y	Y	Y
	900mm	Y	Y	Y	Y	Y	Y	Y
	1200mm	Y	Y	Y	N	N	N	N

Y = yes N = no

ENDUROTRUSS® Product performance

The ENDUROTRUSS® Framing System has been designed in accordance with relevant Australian Standards and the requirements of the Building Code of Australia 2013.

The roof framing system will perform as specified by the ENDUROCAD® 2013 software output documentation if installed in accordance with the recommendations and details set down in this manual and related references.

This manual contains vital information. **PLEASE READ IT CAREFULLY.**

For more information and technical support, contact: info@enduroframe.com.au

Maximum Design Gust Wind Speed (Vh) at Height (h)

Wind Classification	Maximum design gust wind speed (Vh)	
	Serviceability limit state (m/s) (Vh,s)	Ultimate limit state (m/s) (Vh,u)
N1	26	34
N2	26	40
N3	32	50
N4	39	61
N5	47	74
N6	55	86
C1	32	50
C2	39	61
C3	47	74
C4	55	86

Taken from AS4055-2012 Page 5 Table 2

The ultimate roof framing solution

The ENDUROTRUSS® Framing System is your opportunity to gain the competitive edge in roof construction - with added peace of mind.

It is a hassle-free and competitive system delivering a superb job without the need for specialist 'steel skilled' site labour.

You benefit from:

- ENDUROTRUSS® Framing System parts are unique, and the design is patented to keep you ahead
- On-site you receive exactly what you need — no wastage
- Just-in-time delivery means you get what you want — when you want it — and there is less likelihood of damage on site
- The ENDUROTRUSS® Framing System uses the ENDUROCAD® roof design software package, a sophisticated design and detailing package
- The ENDUROTRUSS® system is self locating eliminating the requirement for jigs to assemble even hip rafters have pre-punched holes to self-align with truncated trusses on site
- The ENDUROTRUSS® Framing System only requires fastening on one side which greatly speeds up assembly
- Trusses can either be factory or site assembled giving flexibility in delivery and installation of trusses

- Fully engineered and certified, light-weight steel roof framing
- Parts can be linked together which assists in finding and sorting components for assembly, or pre-cut for factory assembly off the rollformer
- Roof designs for most shapes of roof and ceilings
- All parts are inkjet marked making identification simple
- Easy site assembly that requires minimum skill
- The ENDUROTRUSS® system is installed similar to timber trusses making installation by timber crews simple, using standard timber brackets available for some connections;
- Available in back to back or in-line 'flush' format to reduce the volume on a truck when assembled
- Accurate dimensions

The steel framing advantage

Steel house framing has been well established in Australia for many years. Steel house frames and ENDUROTRUSS® roofing frames are safe and stable – above all:

- They don't rot or warp
- Geometrically complex trusses can be considered due to the self-jigging nature of the trusses
- They are light and easy to erect
- They provide you with very flat roof planes
- They are pre-cambered for straight ceiling lines
- They can be site assembled by people with minimal skill

Who uses The ENDUROTRUSS® Framing System?

Any builder who wants to deliver a quality job at a competitive price.

How does the ENDUROTRUSS® Framing System work?

The heart of the ENDUROTRUSS® Framing System is the patented steel truss which is computer designed and manufactured. The computer system does everything from designing the framing, to supplying the documentation, to controlling the manufacturing equipment.

Simply give your drawings to an ENDUROTRUSS® Framing System Trained Software User and they will do the rest. We input your design data and computer-controlled roll-formers produce the required parts.

How do you use ENDUROTRUSS®?

Apart from the drawings and certification mentioned above, you get delivered to your building site the lengths of roll-formed section required for every truss (and the screws). There are no mistakes because the parts only fit one way, and all parts have identification marks printed directly onto the steel.

Before starting installation, carefully read this installation manual. Further information on fabricating and installation of the ENDUROTRUSS® Framing System can be obtained from videos which can be found at www.enduroframe.com.au/building/assembly_and_installation_videos

Fabrication check sheets and quality control sheets that demonstrate the quality control requirements for assembling the ENDUROTRUSS® system are available from your local ENDUROTRUSS® manufacturer or by contacting info@enduroframe.com. All installation shall be done in accordance with this manual.

Framing System market difference

Make the great leap forward

Read the contents of this Installation Manual and discover how the ENDUROTRUSS® Framing System can work for you. The ENDUROTRUSS® Framing System only requires fastening on one side which greatly speeds up the assembly process. When designed and manufactured correctly, the trusses are certified to comply with the structural engineering software requirements of the BCA.

2.0 On-site handling

2.1 Slings

Trusses must be fully supported in either horizontal or vertical planes when being transported. Care must be taken when tying down and lifting trusses not to put an excessive pressure on chords, webs or joints. For transporting trusses in horizontal planes where a solitary Trusstite screw is used in a chord to web connection, an additional screw may be inserted to provide additional stiffness, especially for "flush" trusses.

Most trusses for single storey work may be lifted by hand, however where craneage is required, sling trusses or truss pieces from top chord panel points as shown in Figure 2.1. Slings should be located at equal distances from truss centre lines and be approximately one-third to one-half the truss length apart.

The angle between the sling legs should be 60 degrees or less and where truss spans are greater than 9000 mm, spreader bar should be used.

Where a truss span exceeds 9000 mm, a spreader bars with attachment to web-chord should be used. Never lift trusses by the apex joint alone.

Note: When manoeuvring any materials by hand, take care not to damage components. Components should be inspected on arrival to site. Damaged components may affect structural integrity.

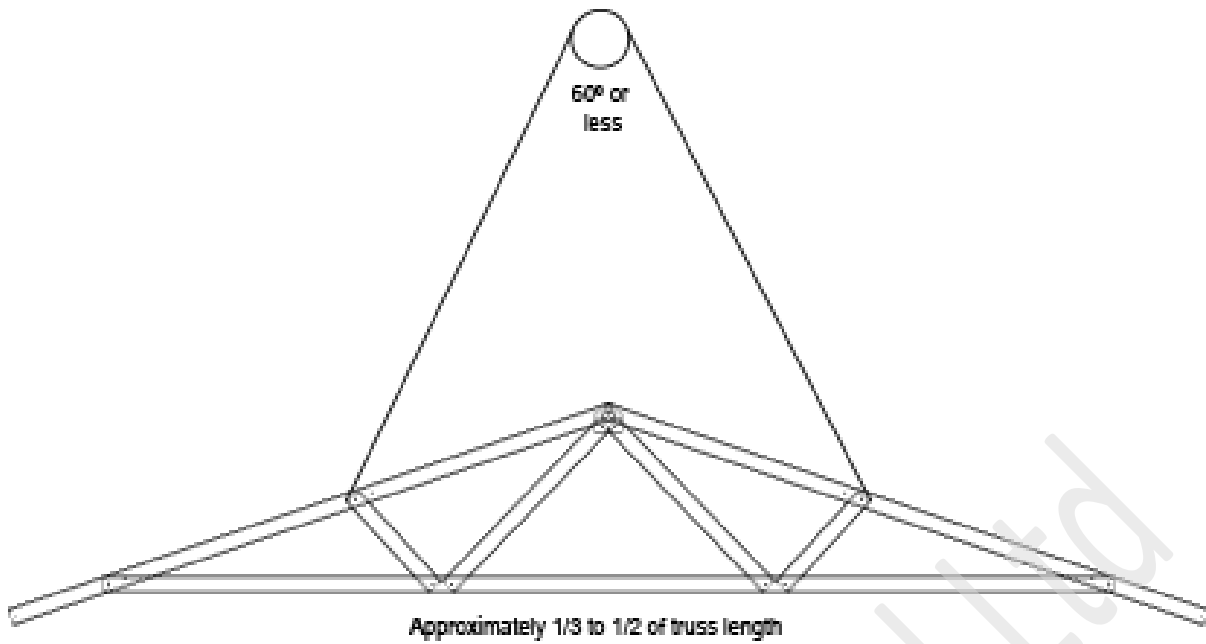

< 9m

Approximately 1/3 to 1/2 of truss length Vertical lifting of trusses - Truss span greater than 9.0

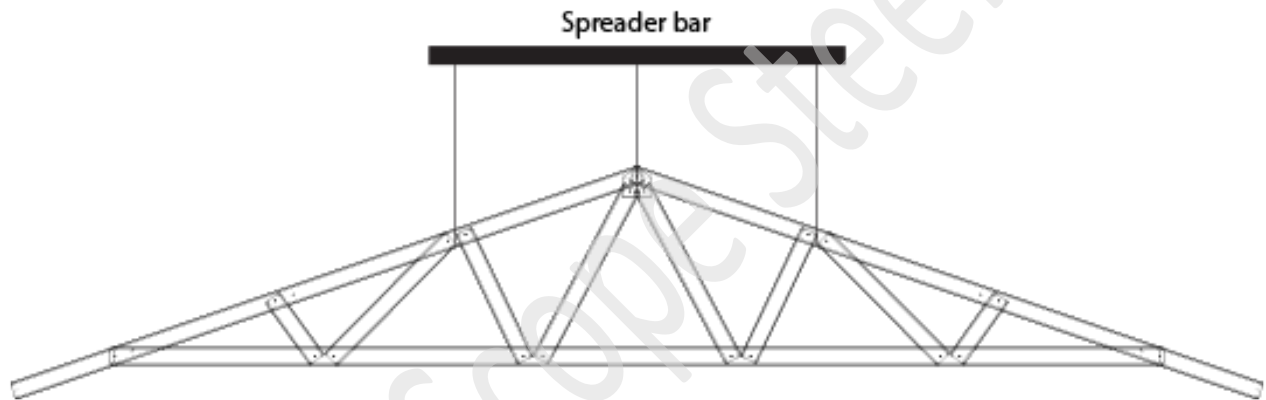

Figure 2.1 Handling

2.2 Roof trusses exposure and storage

Where trusses are stored on site, they should be blocked above firm ground so that they do not come into contact with the soil and to protect them from ground water:

1. If the trusses are stored horizontally, as shown in Fig. 2.2, the blocking should be at 2.0m to 2.5m centres or as required at joints, to prevent bending of the trusses. Avoid using copper, chemically treated timber or EPDM based materials as blocking.
2. If the trusses are stored vertically as shown in Fig. 2.3, they should be supported at the designed support locations or bottom chord panel points, and in a manner that will be prevented from tipping or toppling.
3. The truss chords should be sloped such that water drains off.

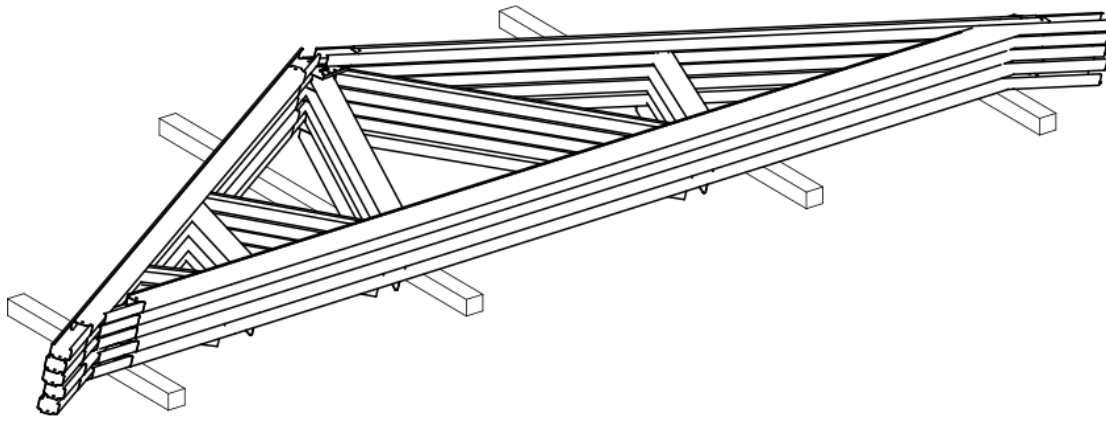

Figure 2.2 Trusses stacked horizontally

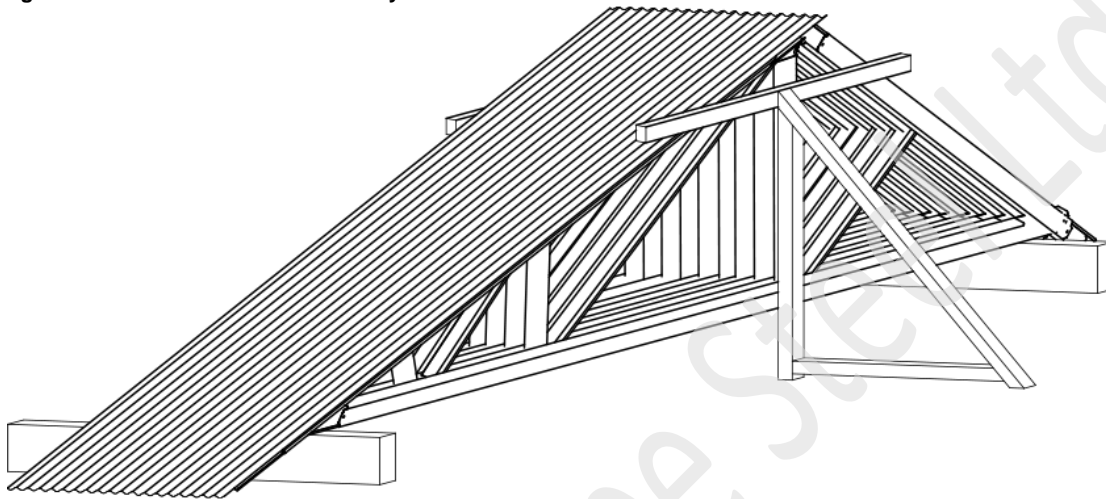

Figure 2.3 Trusses stacked vertically

3.0 Tools & equipment

Required On-site Equipment

When erecting an ENDUROTRUSS® Framing System, the following tools and safety equipment may be required.

Power Tools

- screw gun
- metal cutting saw
- hand held metal cutting saw
- angle grinder

Tool Accessories

- 8mm (5/16") hexagon socket
- extension bar (length up to 150mm)
- Suitable metal cutting blade
- 8mm spanner or socket

Hand Tools

- double action tin snips
- spirit level
- chalk line
- step ladder
- vice grips
- measuring tape

Essential Safety Equipment

- eye protection (safety goggles)
- hearing protection (when using power tools)
- protective gloves

- earth leakage circuit breaker for electrical goods
- all protection harness
- scaffolding, ladders, etc.



Angle grinder

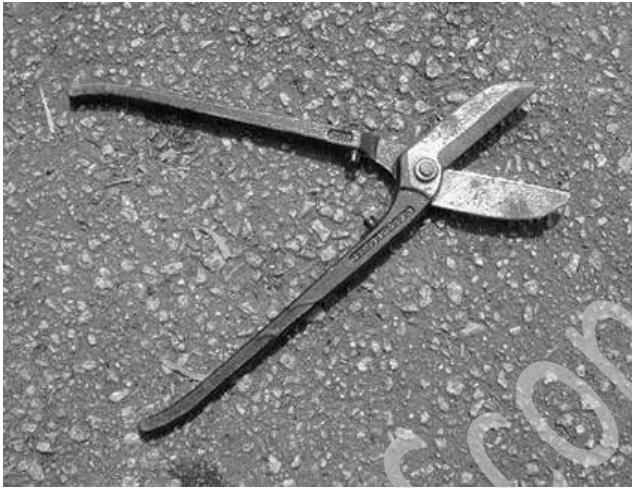

Tin snips



Measuring tape



Screw gun



Metal cutting saw



Hand held metal cutting saw

4.0 Points for construction

Trusses must be installed plumb and straight

While erecting the roof, trusses must be fixed plumb and straight. After fixing, if a bow or tilt is evident, the trusses have not been

installed correctly. In this case, the problem must be rectified before proceeding further.

THE TRUSSES MUST NOT BE MODIFIED ON SITE WITHOUT FIRST SEEKING ADVICE FROM A TRAINED SOFTWARE USER OR ENGINEER.

Correct direction of ENDUROTRUSS® chord profile

The direction of the channel section used for the chord should be as depicted on Truss Assembly diagrams in (see Figure 5.11.) Trusses should be oriented as shown on the truss layout drawing provided and ensure load bearing points shown on the assembly drawings align with load bearing walls.

Material specification

ENDUROTRUSS® sections are roll-formed from TRUECORE® steel complying with AS1397:2011. The standard ENDUROTRUSS® sections are shown in Fig. 4.1. In the grade shown, the number prefixed with G indicates minimum yield stress in MPa; and the number prefixed with Z or AM indicates minimum coating mass in g/m².
0.55mm BMT, TRUECORE® G550 AM150 steel
0.75mm BMT, TRUECORE® G550 AM150 steel
1.00mm BMT, TRUECORE® G550 AM150 steel
1.20mm BMT, TRUECORE® G500 AM150 steel

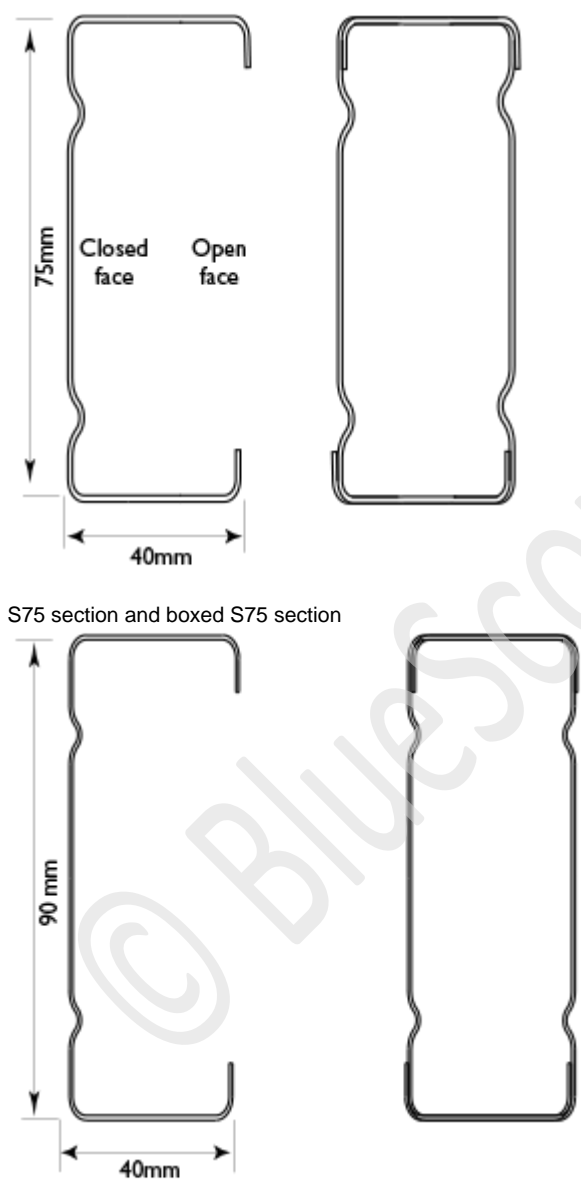

S75 section and boxed S75 section

S100 section and boxed S100 section

Figure 4.1 Section types

Straightness

Trusses and rafters must be installed with an overall out of plane straightness not greater than L/500 where L is the length of the member as shown in Figure 4.2. Differential in vertical bows between adjacent members must not exceed 1/150 of their spacing or 6mm whichever is less.

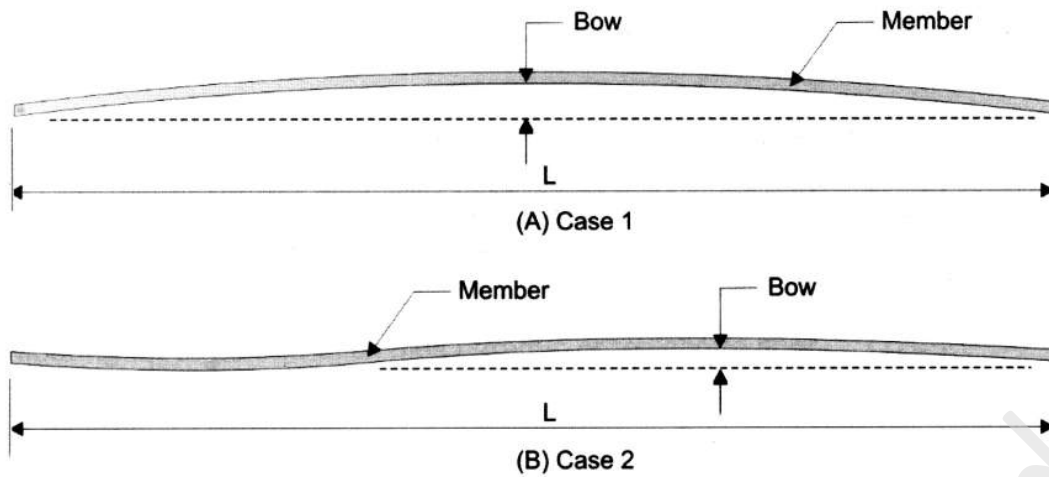

Figure 4.2 Straightness

Plumb

Out of plumb at any point along the length of the truss from top to bottom, must not exceed the minimum of $h/100$ or 20mm unless the trusses are specifically designed to be installed out of plumb. (See Figure 4.3 below)

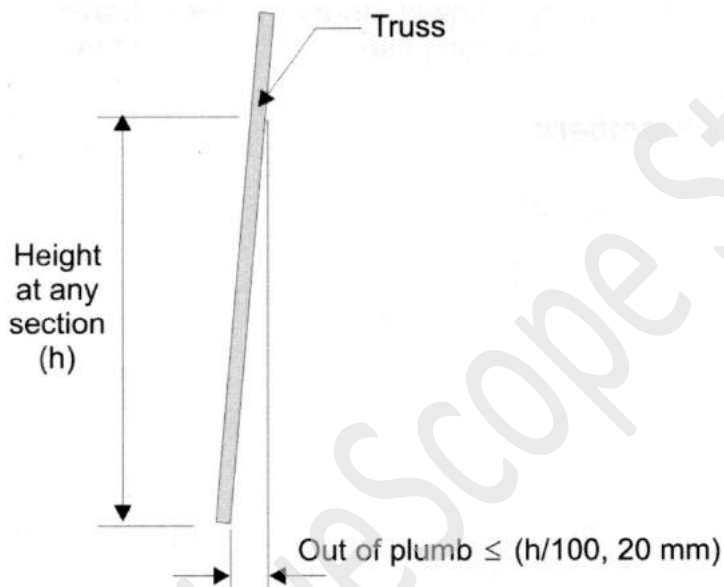

Figure 4.3 Plumb

5.0 Truss identification

A summary of the description of trusses is shown in Figures 5.1 and 5.2, and a glossary of terms is indicated below.

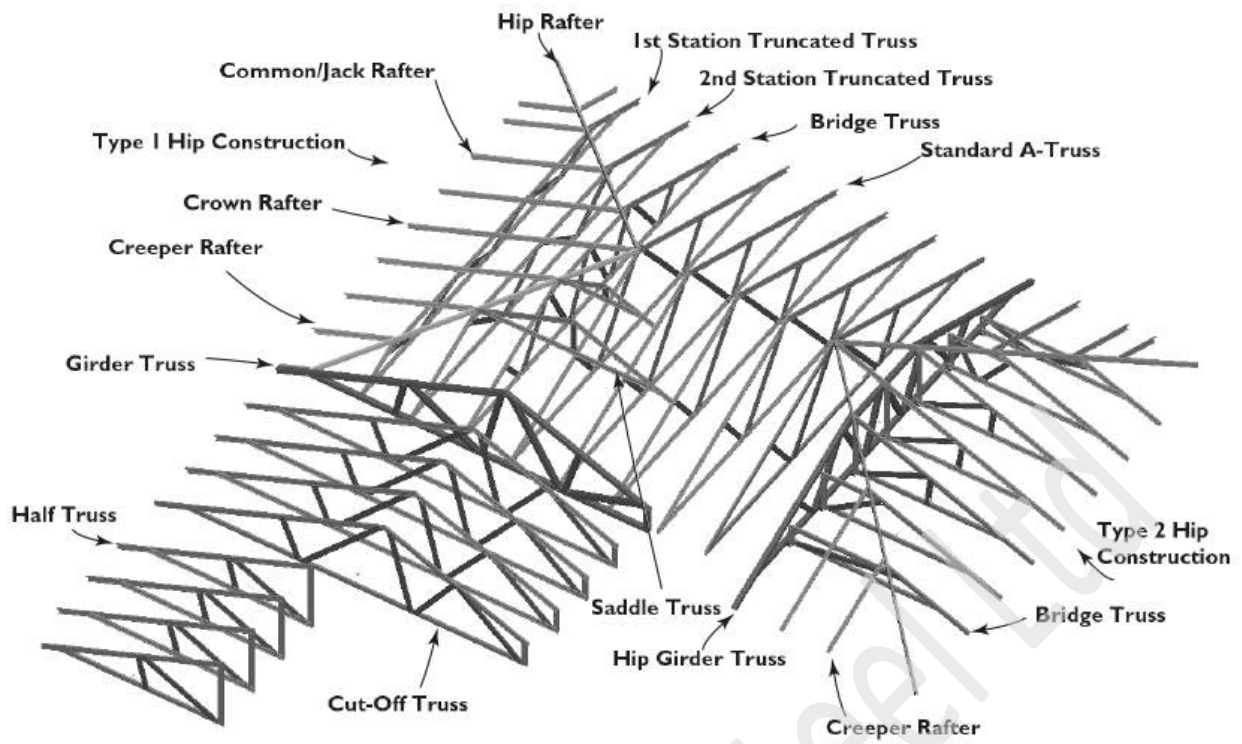

Figure 5.1 Typical Roof truss components

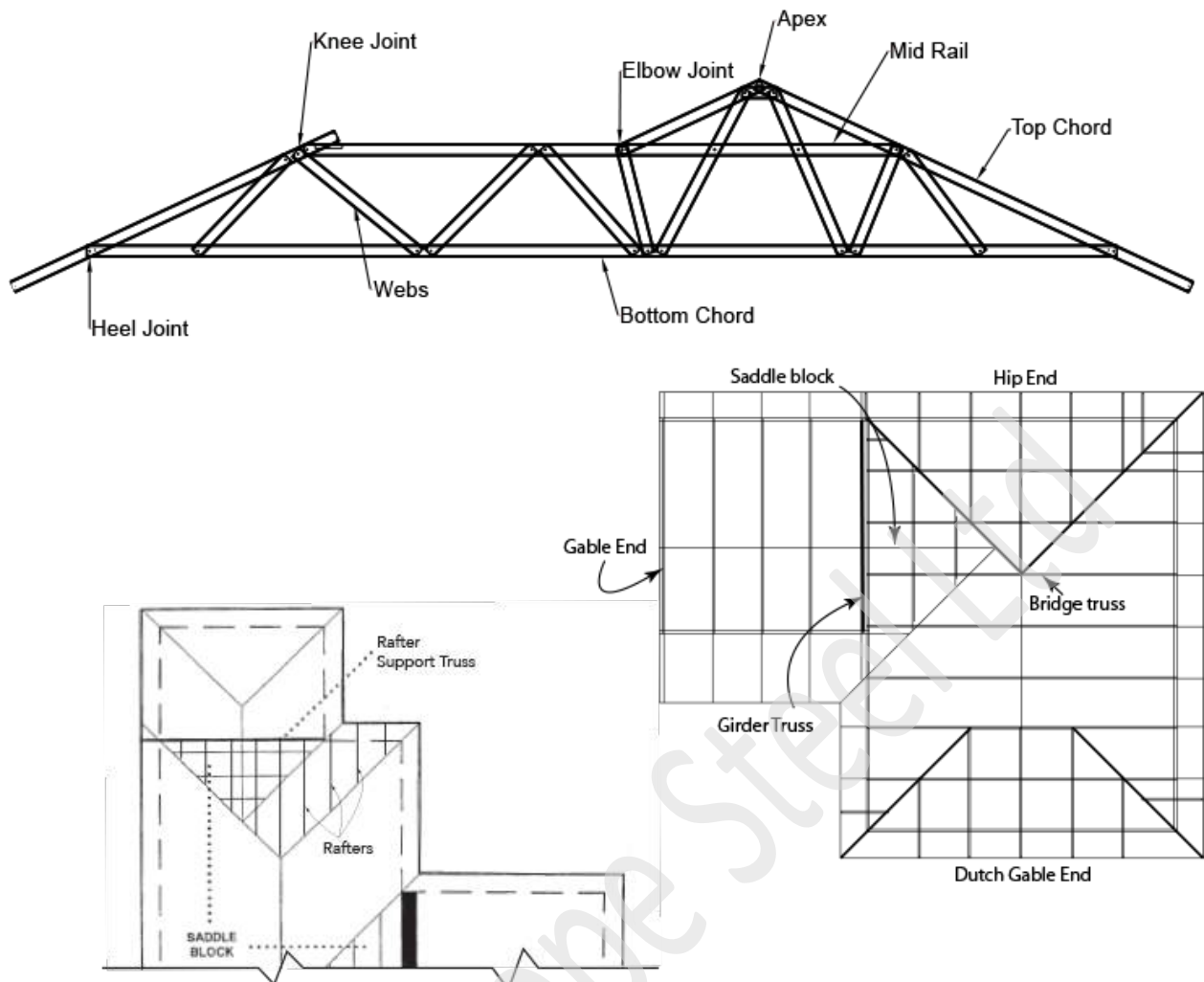

Figure 5.2 Roof truss components (plan view)

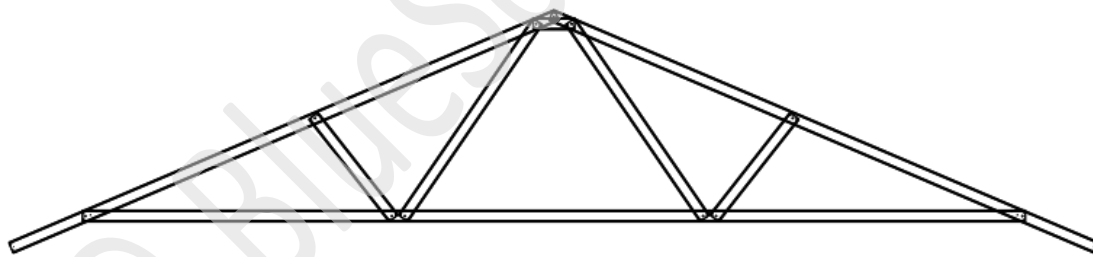

Figure 5.3 Standard 'A' Truss/ Dutch Gable Truss

5.1) **Standard A-Truss:** An A-framed truss supported at both ends by load bearing walls. It forms the main gable roof block. (Refer Fig. 5.3)

5.2) **Dutch Gable Truss:** A Dutch Gable truss is formed when whaling plates are fixed to the flat face of an A-truss to support common rafters.

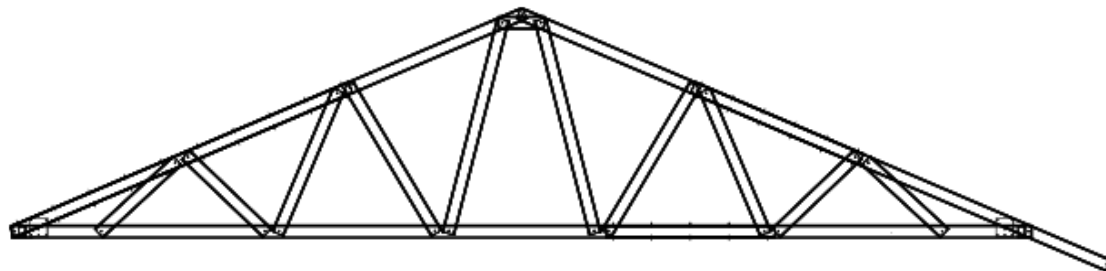

Figure 5.4 Girder Truss

5.3) **Girder Truss:** A structural truss at the end of a roof block that supports incoming trusses from an adjoining block (bridge

trusses). A girder truss may replace a supporting wall or beam. It can be used to support bridge trusses and may be used in lieu of an internal load bearing wall or beam. (Refer Fig. 5.4) A girder truss may be either a single truss or a pair of trusses installed lip to lip.

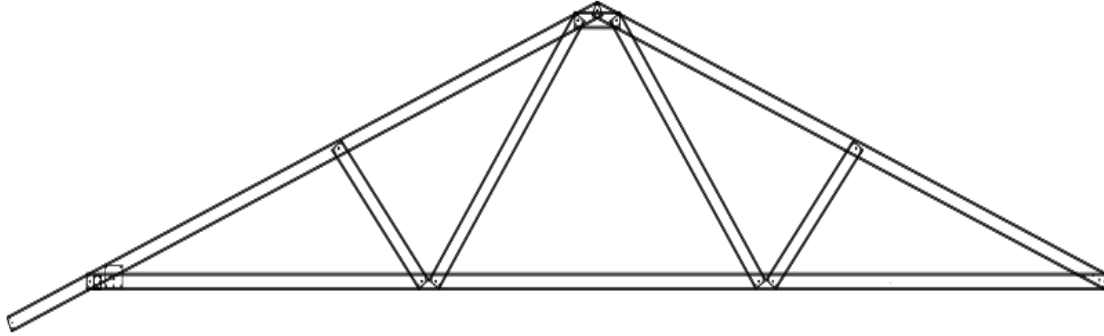

Figure 5.5 Bridge Truss

5.4) Bridge Truss: This truss type can be either a standard truss or a truncated truss with the overhang removed at the heel. A TBJ45 bridge bracket is fitted to connect the truss to a beam or girder truss. (Refer Fig. 5.5)

5.5) Creeper Support Truss: A truss which has an angle lintel fixed to the flat face of the bottom chord. It is used to support the ends of the creeper rafters when a roof incorporates an internal hip.

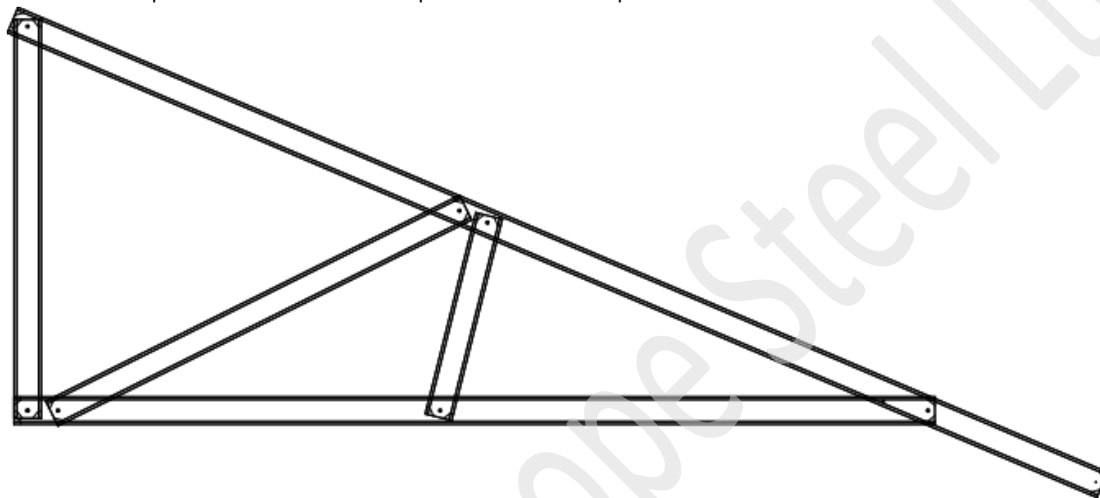

Figure 5.6 Half Truss

5.6) Half Truss: A triangular shaped truss with the end web fixed vertically and at 90 degrees to the bottom chord. It is commonly used to form verandah roofs on the lower floor of two storey homes. (Refer Fig. 5.6)



Figure 5.7 Truncated Truss/Hip Girder Truss

5.7) Truncated Truss: A truss of varying depth with a horizontal top chord. Truncated trusses are usually used to form a hip end. (Refer Fig. 5.7)

5.8) First Station Truncated Truss: The first truncated truss in from hip end wall.

5.9) Second Station Truncated Truss: The second truncated truss from hip end wall.

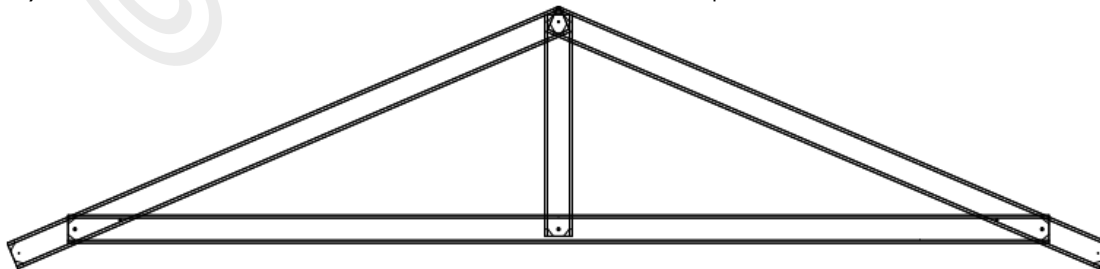

Figure 5.8 Saddle Truss

5.10) Saddle Truss: A truss with the top chords cut at the heel to form a foot cut. It is used to form a valley line when two roof planes intersect. Saddle trusses are supported by trusses or rafters below. (Refer to Figure 5.8.)

5.11) Truncated Saddle Truss: A saddle truss with a horizontal top chord used to form a valley line when two roof planes intersect with a hip end close to the valley. It supports hip end rafters.

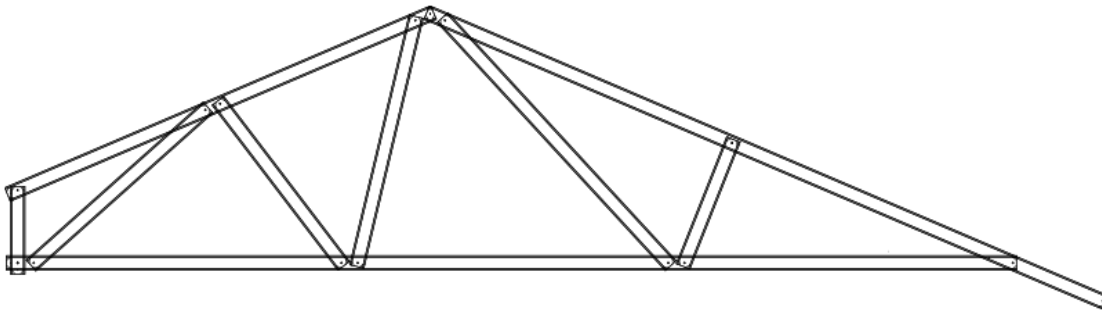

Figure 5.9 Cut-off truss

5.12) Cut off truss: A standard truss with a cut to one or both ends.

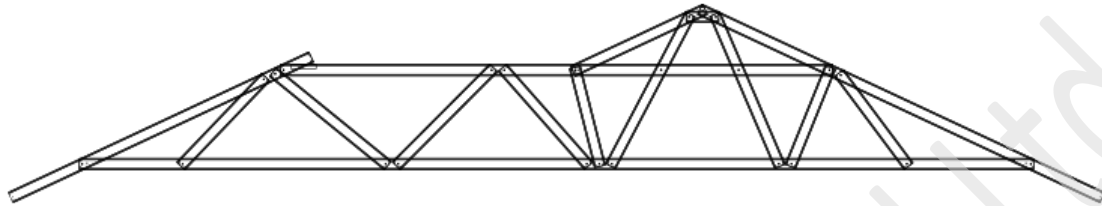

Figure 5.10 Peak truss

5.1.13) Peak truss: A truss that helps to create four or more roof faces. The Peak truss may support one or more hip and valley lines.

in overhang=0 m overhang=0 span=8062 spacing=900 loading=USER+NS0/m,6,-0.6,-0.13,-0.25,0.0,0.0,0.0,0,-1.1,-1.1,0.900,0.0,0.0,0.0,600,0.0,0.2,1,N,1,F,10,N3,.....,5000,8,5000,SEALED) in pitch=22 m off

Design code: AS-4800-2006 (Australian/NZ limit state)

ANALYSIS		QTY
Status	PASS	3
Approved BY		

smart: YES flush: YES LEFT ← RIGHT

Smart: YES indicates that all parts are pre-punched.

Flush: YES Indicates that the webs are notched and installed in the same plane as the chords. Flush: NO indicates that the webs are installed back-to-back with the chords.

TC
SC SECTION A-A
WEB

SC-APEX-E2-60-75-12

SC-HEEL-A-60-75-5

001 002 003 004 005 006 007 008 009 010

8000

Quality check: Top of TOP CHORD to Bottom of BOTTOM CHORD: 1715

Screw locations diagrammatic only, refer connection sheet for details.

Channel truss, Span = 8062

PARTS LIST (per truss)					ASSEMBLY DETAILS				TRUSS DETAILS						
DESCRIPTION	No.	LEN	MAT	QTY	DESCRIPTION	No.	LEN	MAT	QTY	APEX HEIGHT	LEFT PITCH	RIGHT PITCH	UNCROPPED LENGTH	UNCROPPED HEIGHT	WEIGHT
C8075RA	001	8062	0.75	1	C8075RA	080	640	0.75	1	1616	L=22	R=22	9200	1943	30.6
C8075RA	002	4965	0.75	1	SCREW-12-14x20+HEX	-	-	-	8	Precamber = 4.0 mm			DETAILER	DETAILED	SCALE
C8075RA	003	320	0.75	1	TRUSS TITTE	-	-	-	21	FABRICATOR			BlueScope Steel Ltd	JOB NUMBER	TRUSS
C8075RA	004	4965	0.75	1						CLIENT REF:			24_10_11	T015	
C8075RA	010	640	0.75	1						CUSTOMER			Builder name		
C8075RA	020	1320	0.75	1											
C8075RA	030	1240	0.75	1											
C8075RA	040	1719	0.75	1											
C8075RA	050	1719	0.75	1											
C8075RA	060	1240	0.75	1											
C8075RA	070	1320	0.75	1											

Page 1 of 1

Figure 5.14: A typical truss assembly sheet as produced by ENDUROCAD® SOFTWARE.

6.0 Truss Assembly

6.1 ENDUROTRUSS® Framing System marking and branding

All ENDUROTRUSS® Framing System parts are coded with information to assist erectors in the assembly process. This matches the part information shown on the assembly drawings.

All ENDUROTRUSS® Framing System parts are coded with the following:

Part Number, Truss Number, Job Name/Number, Part Length, and Part Usage.

They also contain the rollformer number and date of manufacturing for traceability purposes.

With this information, erectors can identify what the part is and where it is intended to be used in the structure. The illustration below shows how the coding works:

The sections are marked when produced in accordance with Section 6.1 of this manual.

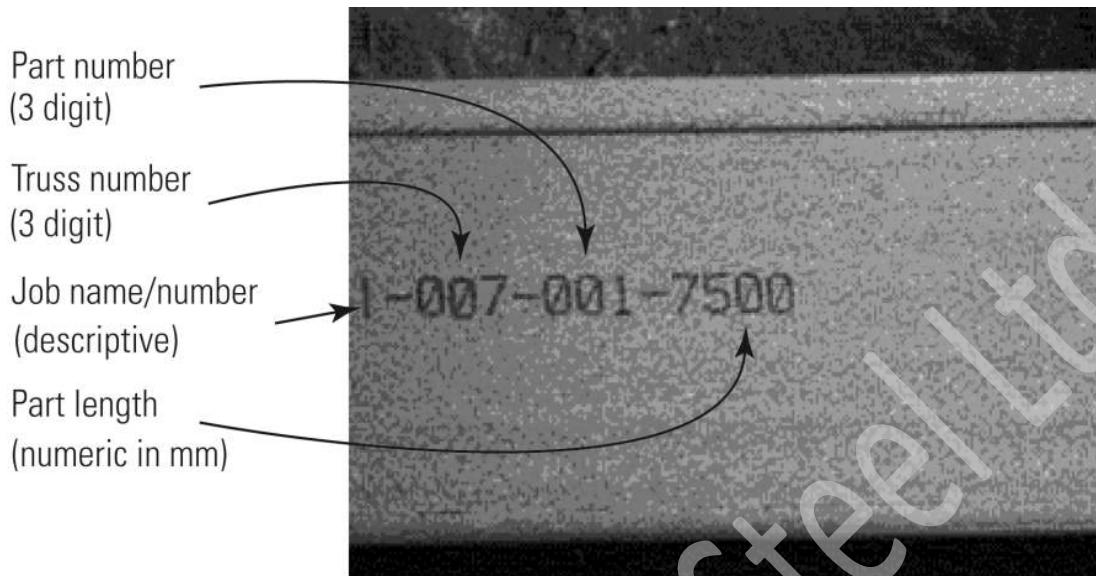

Figure 6.1 Marking and branding

So the above example illustrates that this member is for Job Number 1, it is part of truss number 7 (as numbered by the software in the construction drawings), it is part number 1 and is 7500mm in length.

6.2 Chord to chord connection identification

Connections are identified on the truss assembly sheet by a connection code. The connection detail is displayed on an ENDUROCAD® software generated connection sheet showing all the connections used in the specific job. The chord to chord connection code is displayed next to the connection on the assembly sheet. (Refer Figure 6.2.)

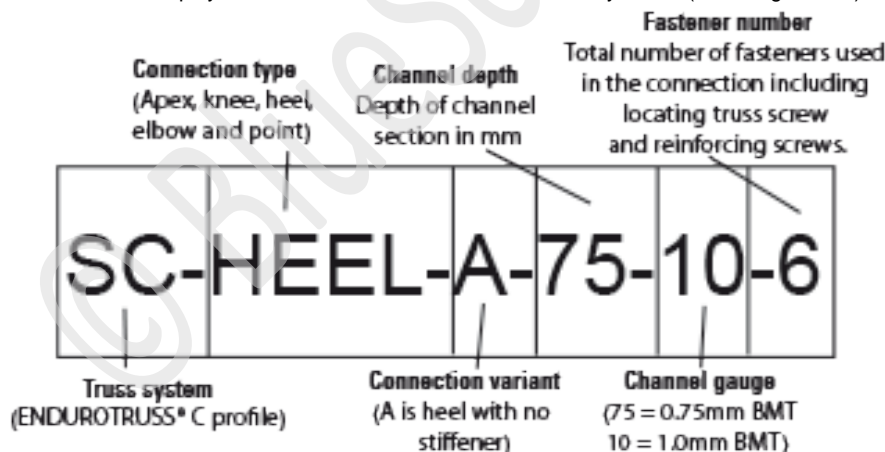

Figure 6.2 Connection identification

The Connection code is explained using the above example

Example SC-HEEL-A-75A-75-10-6

Field 1 The truss system- in this case ENDUROTRUSS® C profile

Field 2 The connection type - Options:

APEX, KNEE, HEEL, ELBOW and CHORD POINT

Field 3 The Connection- Type A is a heel for a tiled and sheet roof

Field 4 The depth of the channel section

Field 5 The gauge of the channel - 10 is 1.0 BMT and 75 is 0.75 BMT

Field 6 The number of fasteners used in the connection. Includes any locating truss screw, reinforcing screws or stiffener connection fasteners.

6.3 Fasteners

Truss members are joined together with two types of fasteners.

A locating Trusstite® truss screw which is a hex-head fasteners with a trilobular thread for fixing through pre-punched holes and a #12-14x20 hex-head self drilling reinforcing fasteners. Fasteners should always be supplied by the manufacturer of the trusses and be in accordance with the specifications described in the ENDUROFRAME® Design Manual for mechanical and coating properties. All fasteners should have a minimum Class 3 coating. The specifications of the locating Trusstite® truss screw may be either a:-

- #17-15x15 hex. head or
- 5/16"-12x17 hex. head screw

The use of the correct fasteners in the quantities shown in the truss fabrication drawings are essential to ensure the design capacity of the trusses are achieved.

The following illustrations show the typical steps for assembly of a truss. In this example the webs are linked for ease of locating the parts.

6.4 ENDUROTRUSS® Framing System assembly

The following illustrations show the typical steps for assembly of a truss.



Step 1 - Part Identification

Unpack the trusses and sort into truss lots using the branding as a guide. Identify the chords and webs from the branding information on the parts.



Step 2 - Truss Layout & Chord Assembly

Identify the chords and lay toes down on a level surface or assembly table and align as per assembly drawing. The chords should be pre-notched allowing parts to overlap as shown. Pre-punched holes are provided for locating truss screw to connect the chords at the apex, heel and knee.

Note: branding is on the side flange which will be on the inside of the truss chords which can aid in laying out.

Step 3 - Align holes and install a locating truss screw - fix at heels

When carrying out the primary assembly of the heel align notch holes as shown and install a locating truss screw in holes .



Step 4 - Fix at apex or knee and install a locating truss screw

Align notch holes as shown and install a locating truss screw in holes.



Step 5 - Web Installation

Separate linked webs by cutting or snapping pieces apart. If webs are joined they will be attached in the order required for assembly (Left to right). Snip or snap the webs apart and position each one over the truss chords near their final location. Where flush truss is being used (as in this example), the branding on the webs will face towards the top of the truss and toes of the channel will face down. For a non-flush or back to back truss the flanges of the webs face up and no notches are provided at the web ends.



Step 6 - Align holes and fix connection with a locating truss screw

Using part identifier numbers layout the webs in accordance with the Assembly Sheet. Line up the 6mm locating holes on the ends of the webs with the appropriate holes on the truss chords. If a "flush" truss is being installed the flanges of the web are to face downwards in line with the truss chords. Install a locating truss screw into the aligned holes ensuring that the screw is driven firmly home and does not strip. Should the locating truss screw strip, reduce the driver torque and place a 12-24x20 self drilling screw 20mm minimum from the locating truss screw.



Finished knee web connection (unreinforced)



Finished connection (reinforced)



Step 7 - Overall Quality Check Before inserting any stiffeners or reinforcing screws check the overall dimensions of the truss against the Assembly Sheet.
For a complex shape truss, lay it on top of a previously assembled one and check they are the same.

6.4 ENDUROTRUSS® splicing

Large span trusses may be too large to economically transport and components may be too long to rollform and handle through the manufacturing workshop. The detailing software allows the Trained Software User to set a maximum component length. Where this length is exceeded the software will create a splice to subdivide the component. The splice will be located between truss panel points and close to the centre of the panel.

The 2 bottom chord members connect using the standard notched end as shown in Figure 6.3.

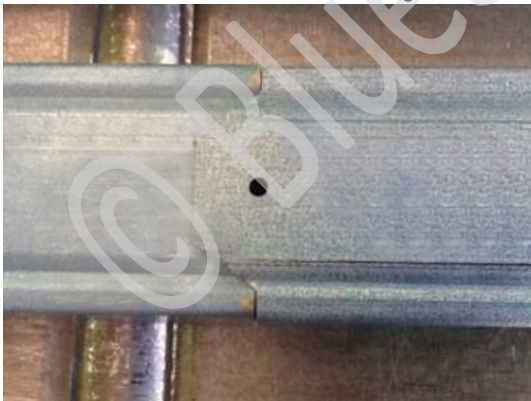

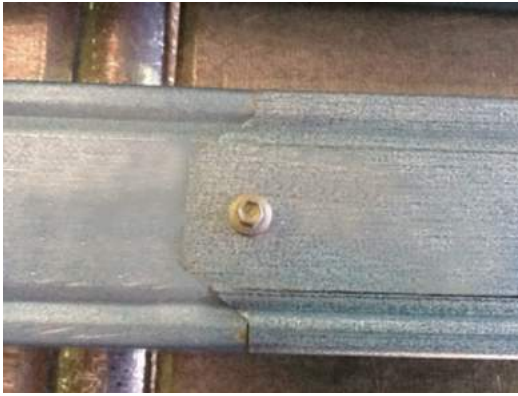

Figure 6.3 Bottom Chord connection at splice

After the chords are connected, a boxing piece is placed over the chords and fixed with 12-14x20 self drilling screws following the connection details in Figure 6.4. Boxing member is Ribbed Channel of the same gauge and depth as the truss.

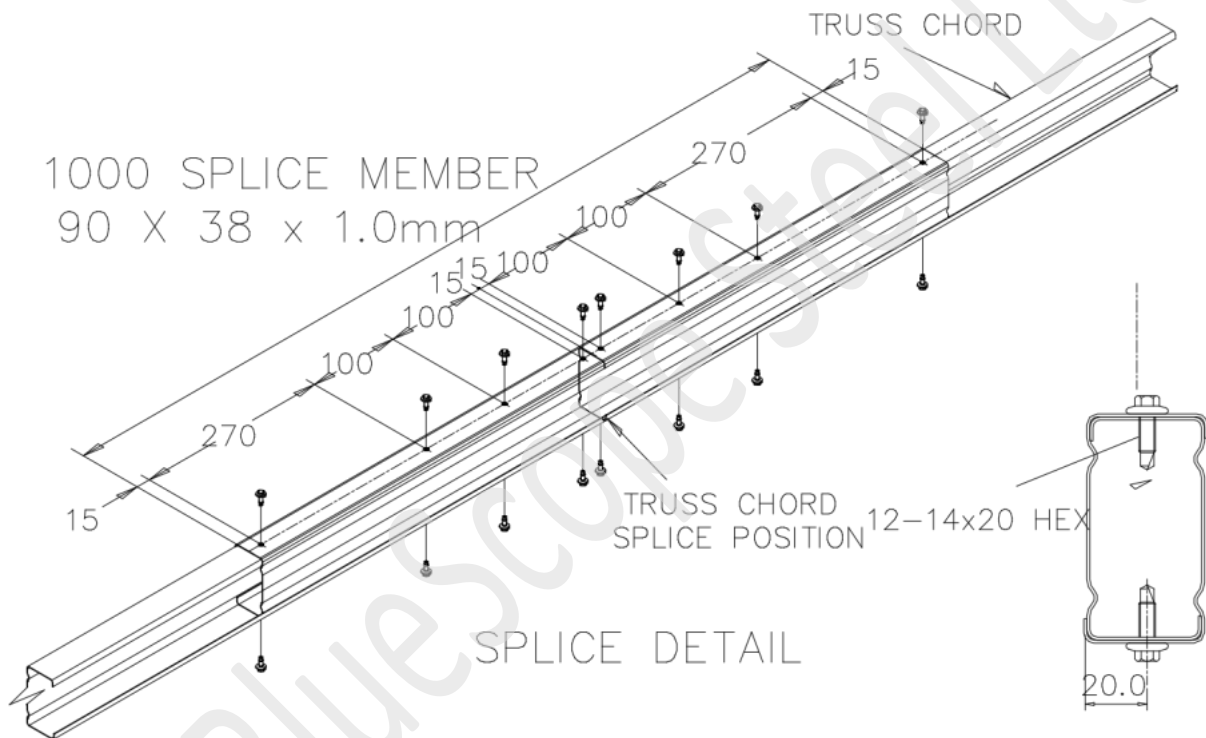

Figure 6.4. ENDUROTRUSS Splice Details

6.5 ENDUROTRUSS® Framing System stiffening and re-inforcement

Refer to the ENDUROCAD® software generated connection drawing and the assembly drawings to identify reinforcing screws and stiffeners required to complete truss assembly. Primary fixing screws are self-locating Trusstite® screws fastened through pre-punched holes, while reinforcing screws are #12-14x20 hex-head self-drilling fasteners, without washers. Stiffening screws should be installed a minimum of 21mm from each other and the locating screw and a minimum distance of 10mm from the edge and 17mm from the end.

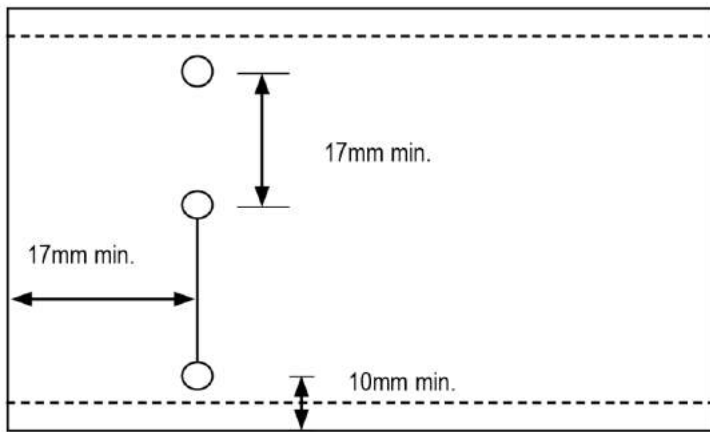

Fig 6.5 Stiffening screw distances

From the appropriate connection drawing, identify the location and type of stiffener and/or the screws required. Install as shown on the drawing. Different stiffeners are specified for various loading and geometry.

6.5.1 Web stiffening

Identify webs requiring reinforcing screws by referring to the code printed on the part or the truss assembly drawing. For example 030-3 refers to three fasteners required on each end of web 030. For larger trusses and flush, an additional screw may be placed in unreinforced webs to strengthen the trusses in the horizontal plane during handling, although they are not required for structural purposes. The position of the additional screw is as shown in Step 6 of Section 6.3.

6.5.2 Apex stiffening

Identify the number and location of reinforcing screws required for chord to apex plate connection by referring to the connection drawing for the apex type. The range of apex stiffening options are shown in **Table 3**.

For example SC-APEX-E1-75-10-5 means to install one locating truss screw and four number #12-14x20 hex head screws.

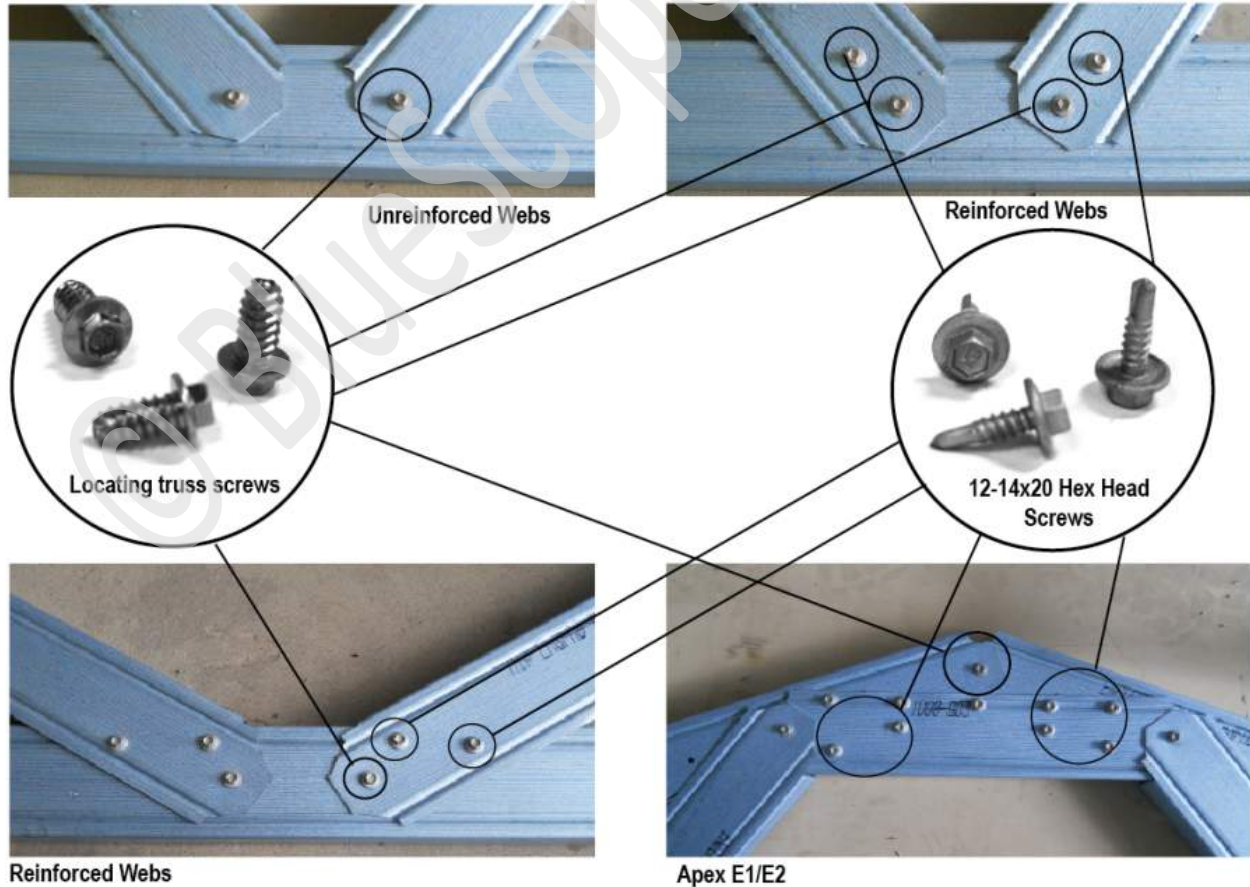
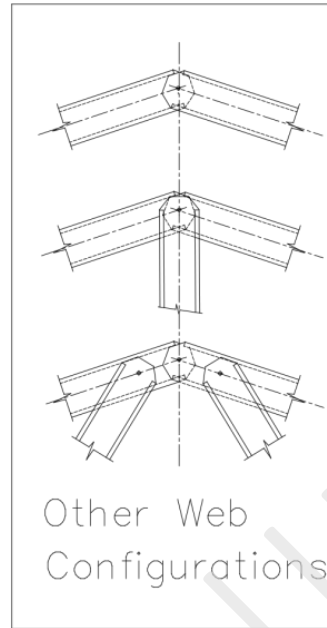
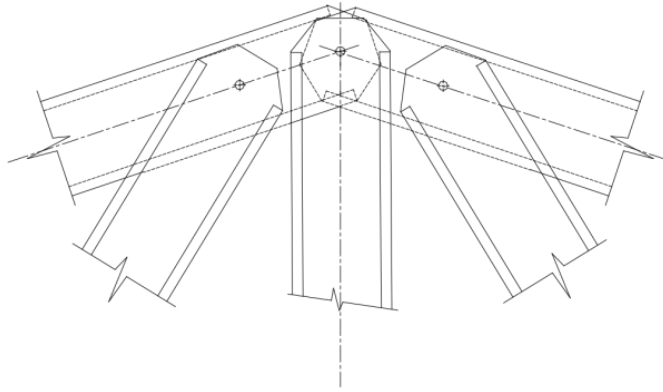

Table 3 Apex types

Apex A



No stiffeners or plates and a single Trusstite® connection

Apex E1

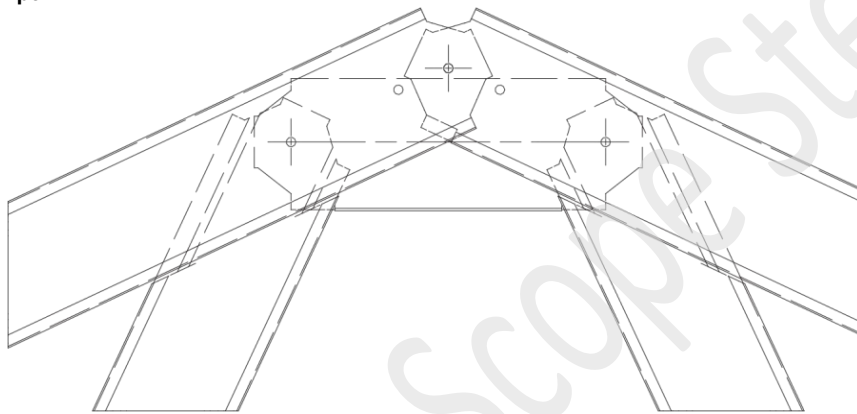

Notched C stiffener plate across apex with webs connected to top chord

Apex HS

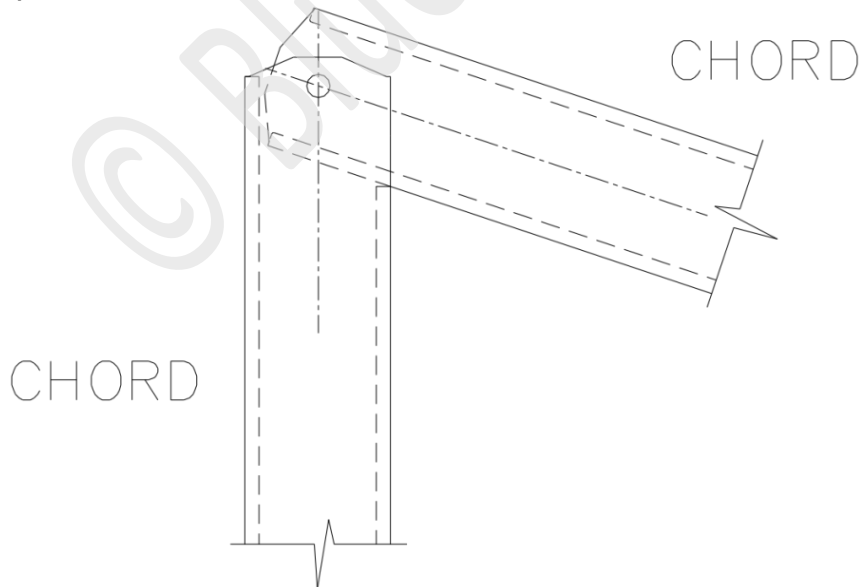

Back-to-back chord sections

Apex F

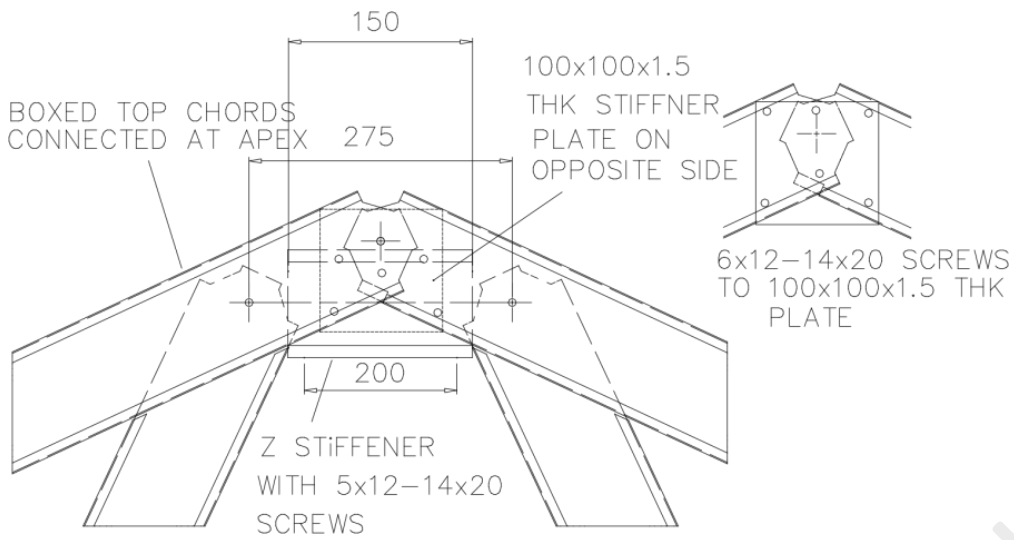

200mm long Z section over 125 x 125mm x 1.5mm stiffener for 90mm section or 100mm x 100mm x 1.5mm stiffener for 75mm section

Apex C

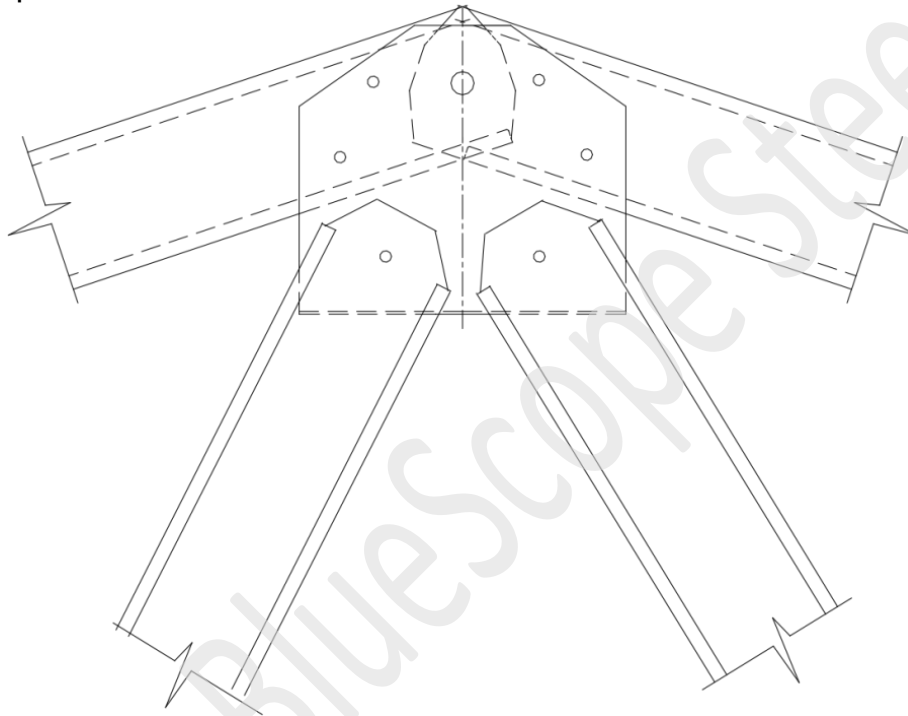

Standard apex plate connection

Apex E2

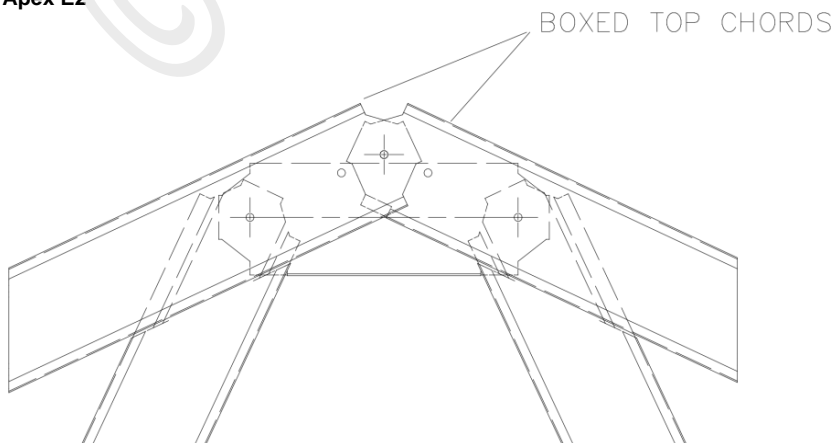

Notched C section with boxed top chords

Apex HSF

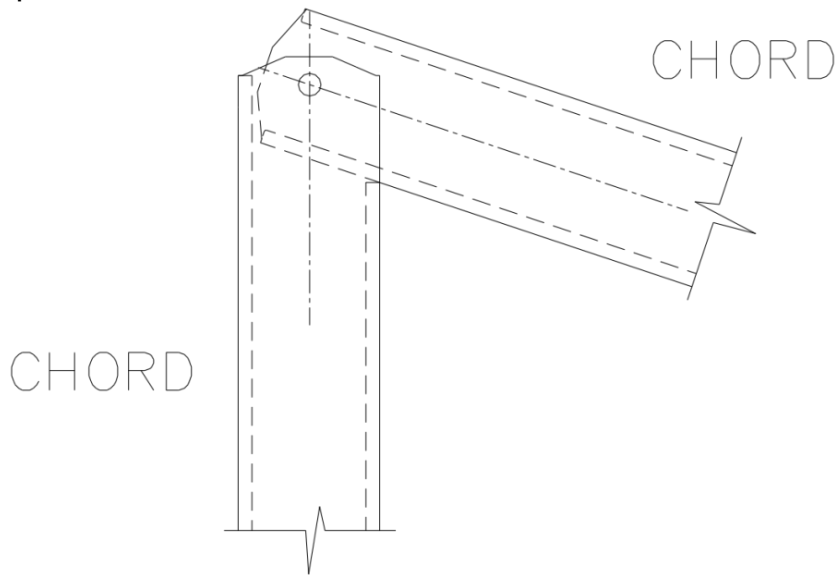

Flush chord connection

6.5.3 Heel Stiffening

A range of heel stiffeners are available to enhance truss capacities and are changed depending on whether a truss or sheet roof is being used. From the appropriate connection drawing, identify the location and type of stiffener and/or the screws required. Install as shown on the drawing.

Heel A

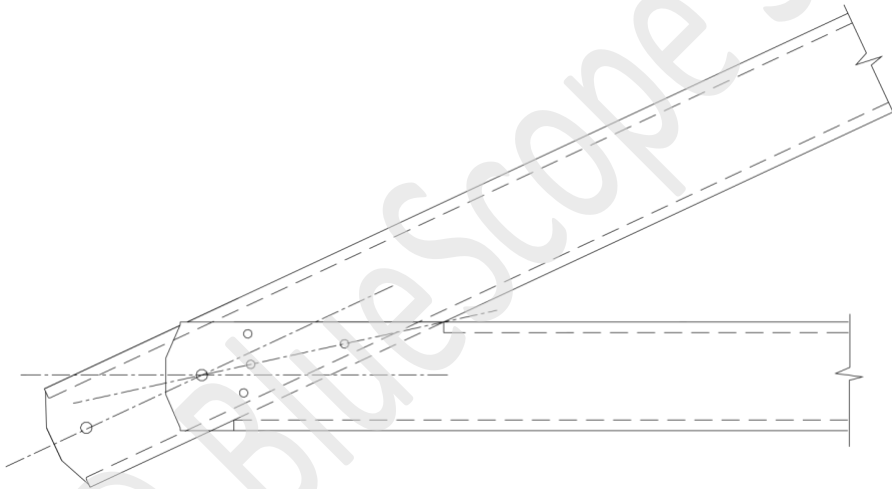

Heel Connection with no stiffener or brackets. Used for lower span tile roof and low wind areas sheet roof

Heel B

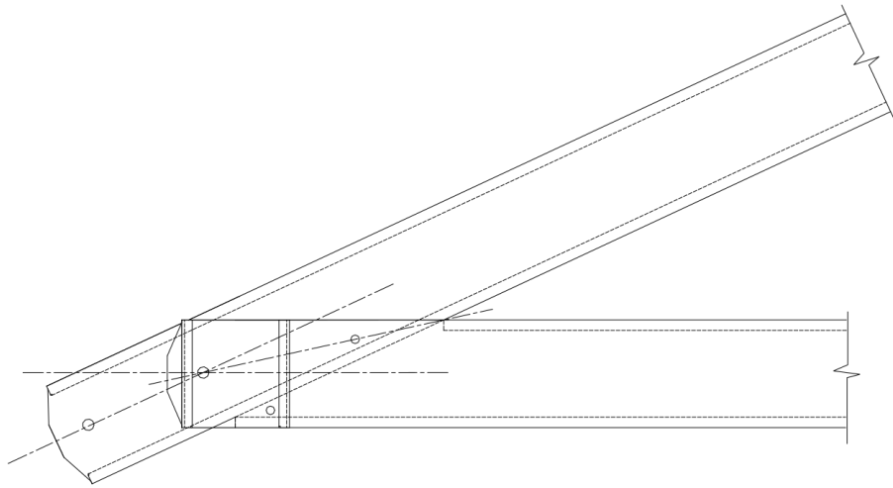

Heel Connection with vertical channel stiffener. Stiffener increases bearing capacity of connection

Heel E1

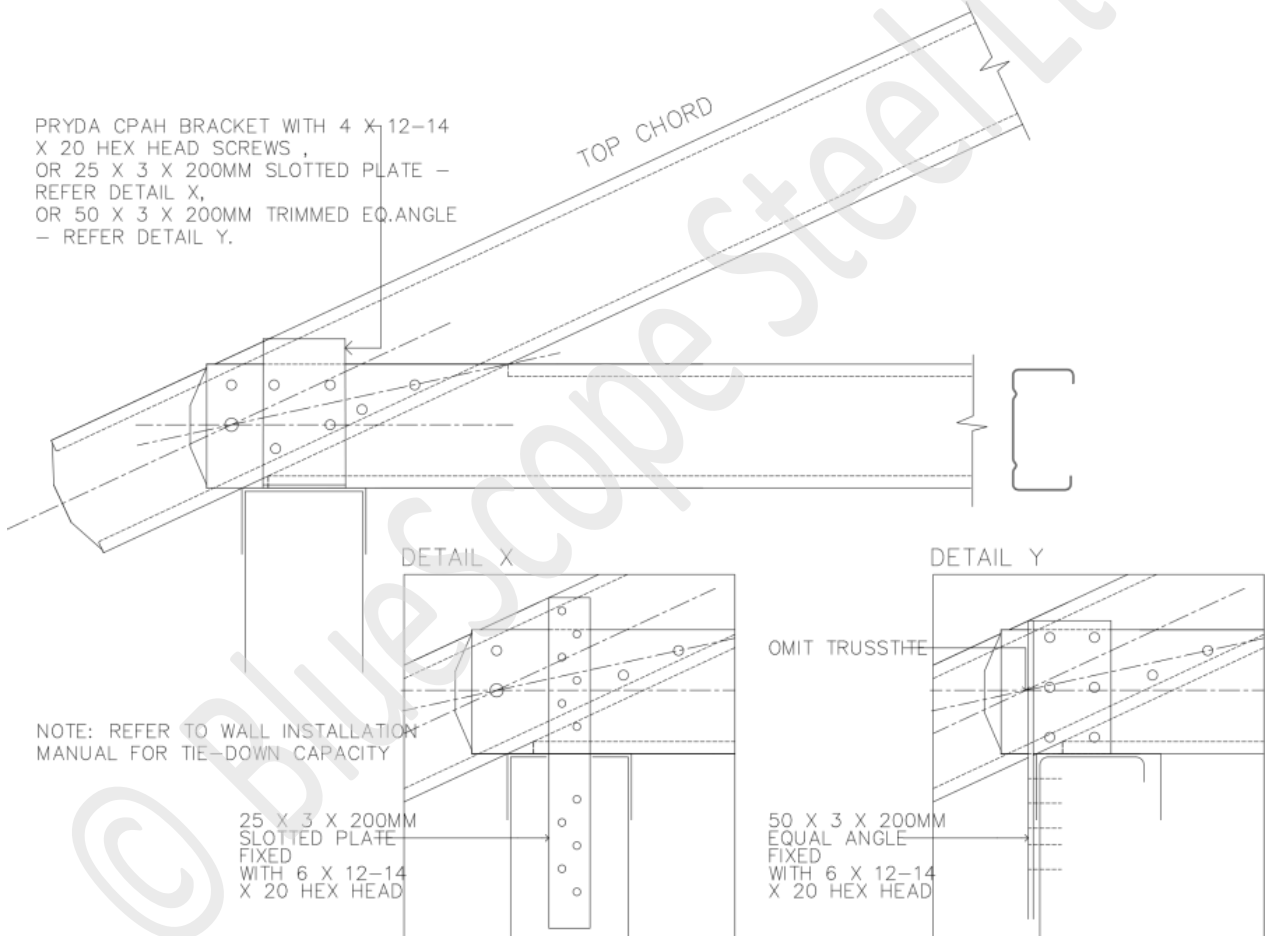

Heel strengthened with CPAH bracket, 25 x 3 x 200mm plate tie or 50 x 50 x 3 x 200mm equal angle tie

Heel E2

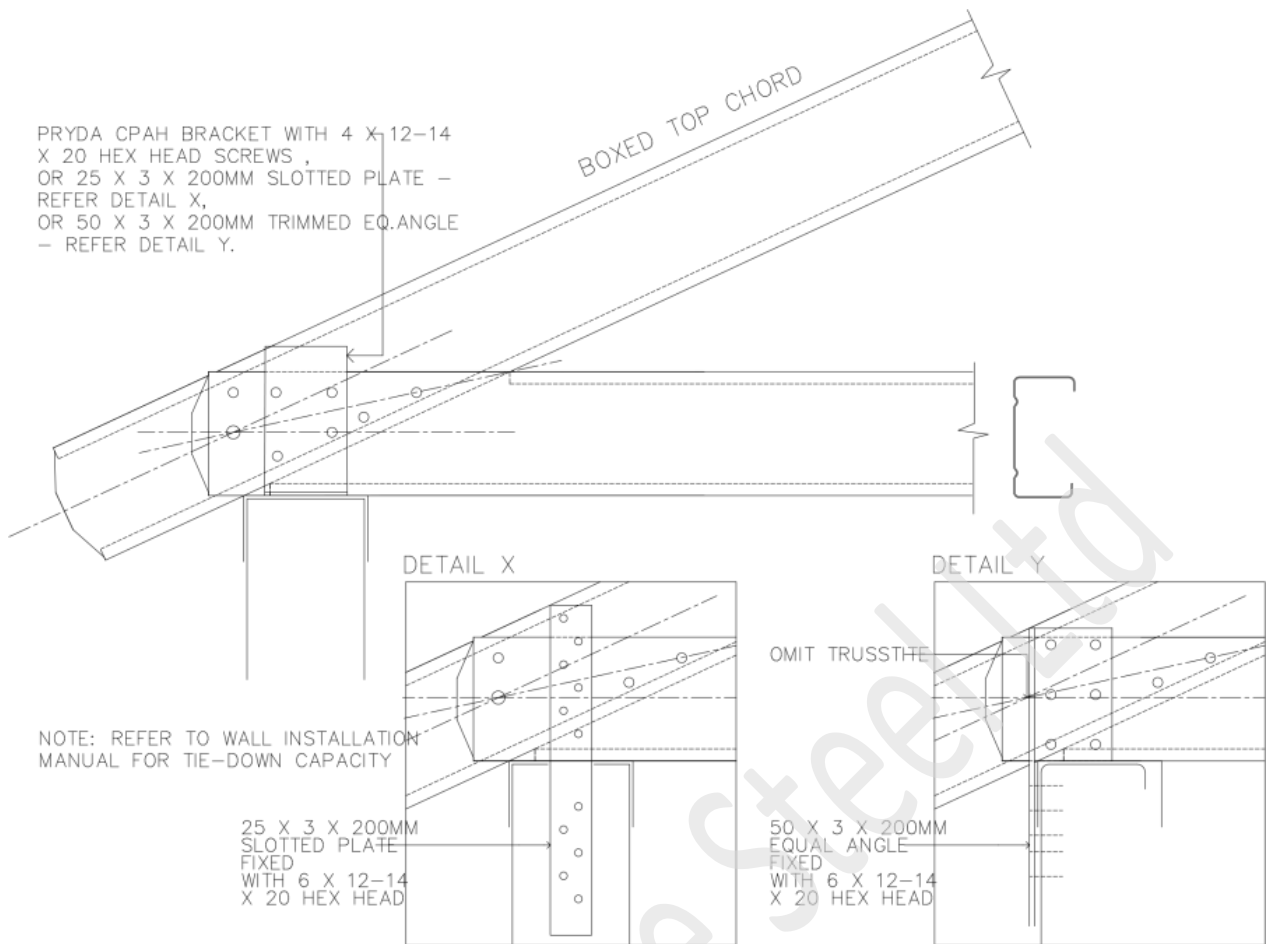

Heel strengthened with CPAH bracket, 25 x 3 x 200mm plate tie or 50 x 50 x 3 x 200mm equal angle tie, with a boxed top chord.

Heel F1

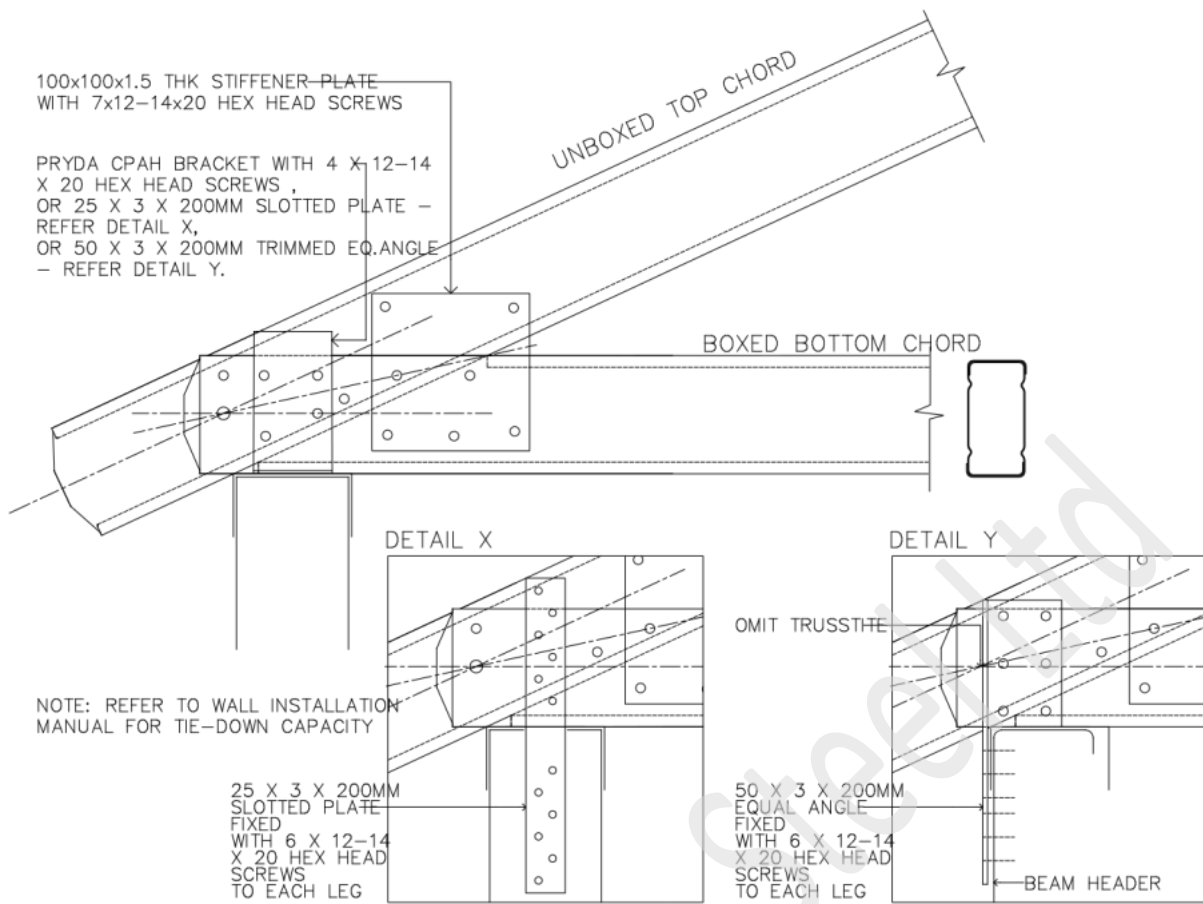

Heel strengthened with CPAH bracket, 25 x 3 x 200mm plate tie or 50 x 50 x 3 x 200mm equal angle tie and 100x100 x1.5mm plate for 75mm truss and 125x125x1.5mm for 90mm truss
Heel F2

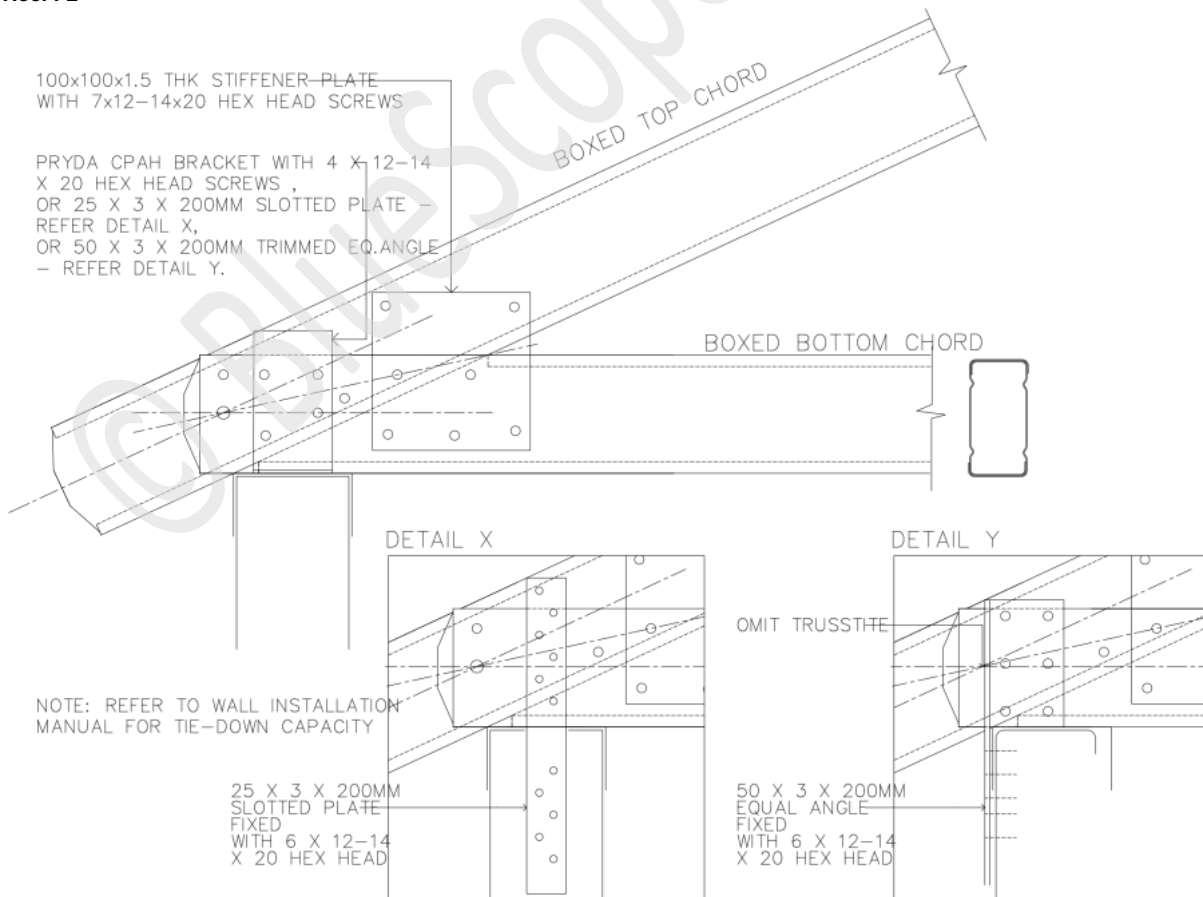

Heel strengthened with CPAH bracket, 25 x 3 x 200mm plate tie or 50 x 50 x 3 x 200mm equal angle tie, and 1.5mm plate with

a boxed top chord 100 x 100 x 1.5mm plate for 75mm truss and 125 x 125 x 1.5mm for 90mm truss

Heel G

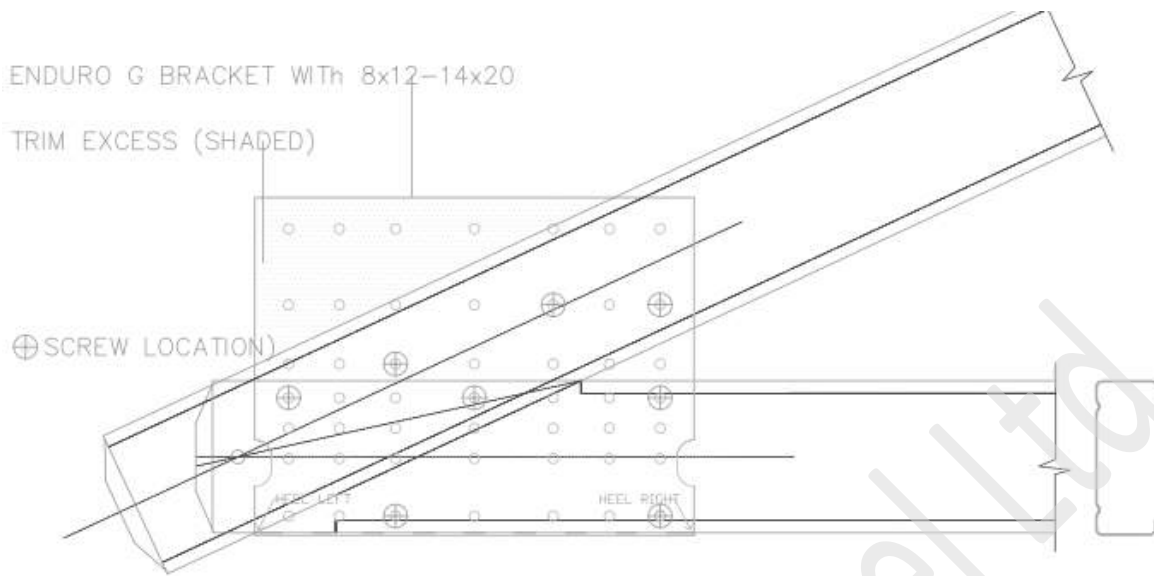

1 TRUSSTITE + 8X12-14X20 HEX SCREWS

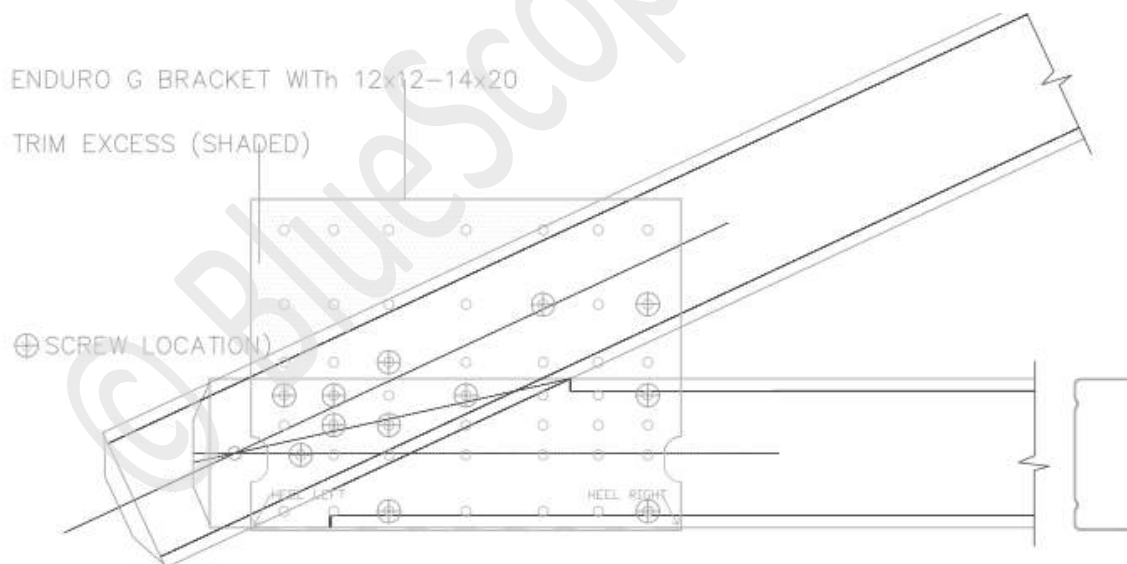

1 TRUSSTITE + 12X12-14X20 HEX SCREWS

Heel strengthened with Heel-G bracket (200x35x1.5 thk)

Heel HS

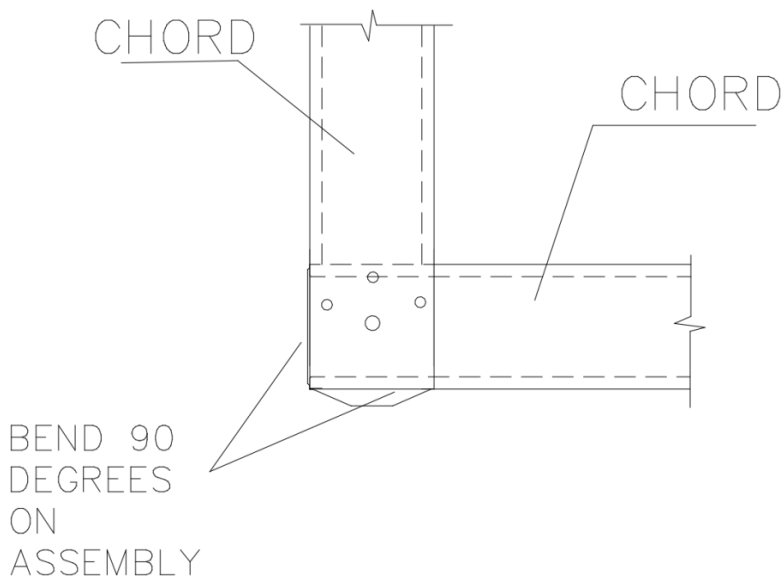

Half Truss Heel where the vertical member is designed as a Chord

Heel HS-F

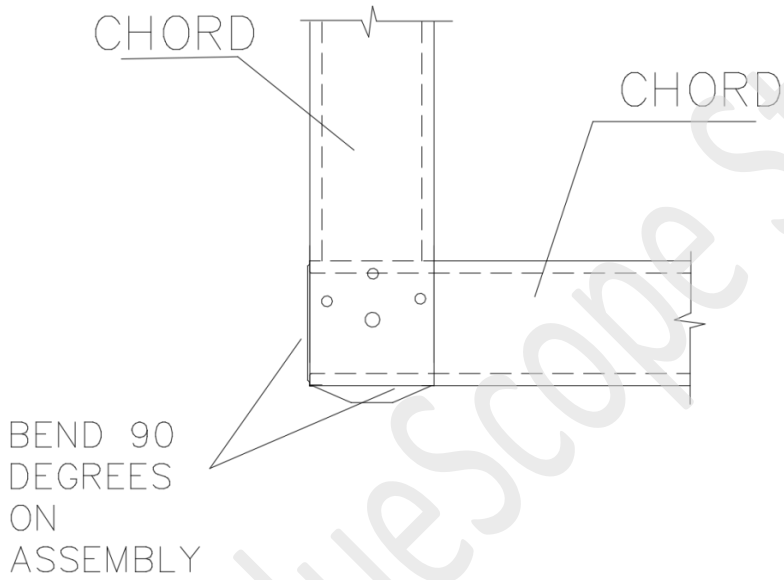

Half truss Heel where the end member has chord attributes and is flush

Heel HS-5-A

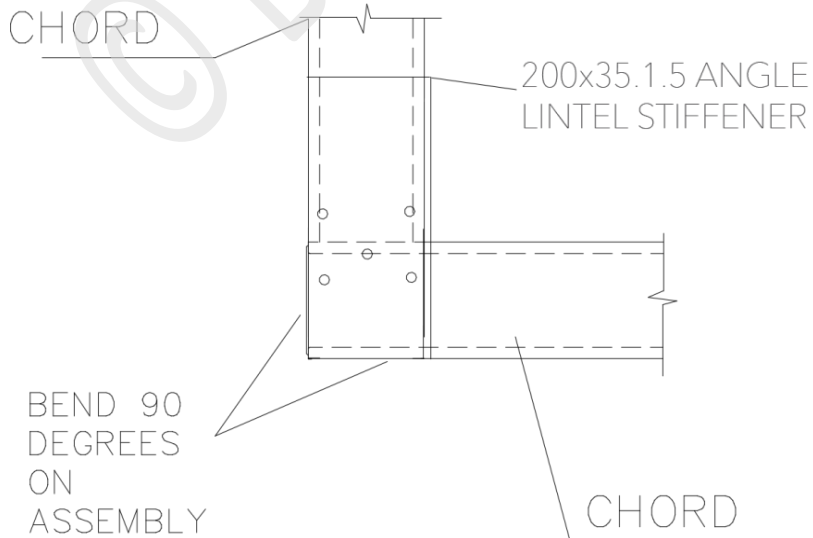

Stiffened version of the HS-F connection using a 200x35x1.5mm lintel section

6.5.4 Knee Stiffening

From the appropriate connection drawing, identify the location and type of stiffener and/or the screws required. Install as shown on the drawing.

The 35 x 35 x 200 x 1.0mm angle stiffener is provided for high compression knee connections (Knee Type D) or a 125mm x 125mm x 1.5mm plate (Knee Type E).

Summary of Knee Stiffeners is below in Table 5.

Knee A

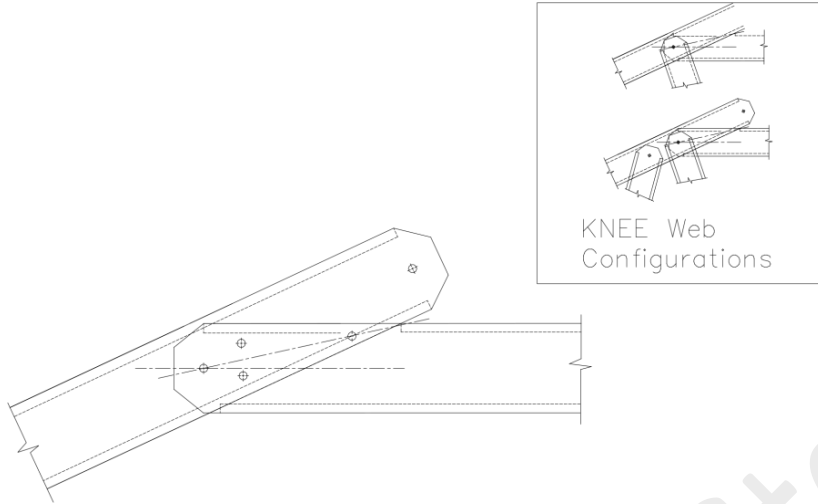

Unreinforced knee

Knee C

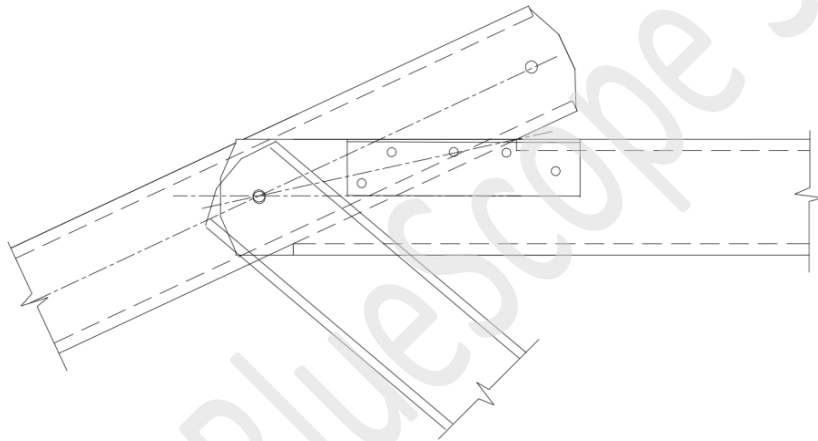

Horizontal 35 x 35 x 1.0mm angle stiffener, 200mm long

Knee E

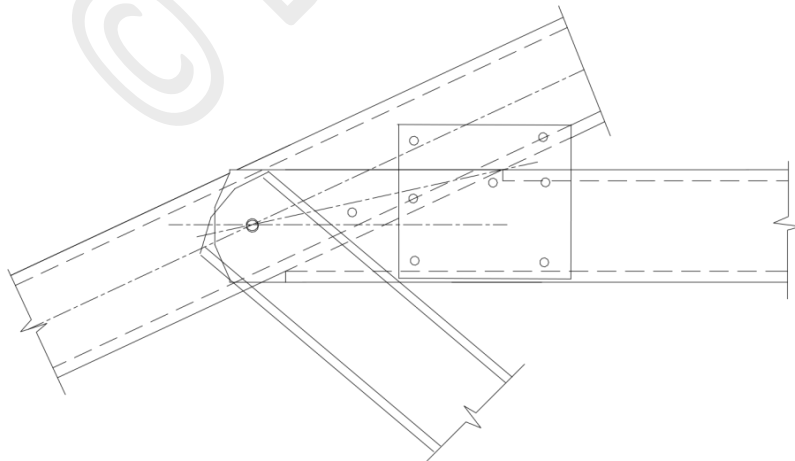

Knee strengthened with 1.5mm plate to top chord preventing buckling Use 100 x 100 x 1.5mm plate with 75mm chords Use 125 x 125 x 1.5mm plate with 90mm chords

6.5.5 Web Stiffening

Web stiffening may be required when flush truss is selected to increase the strength of the web in compression. This is done with a 200 x 35 x 1.5mm angle lintel, minimum 90mm long with the nominated number of fasteners into the connection as is shown in the figure below.

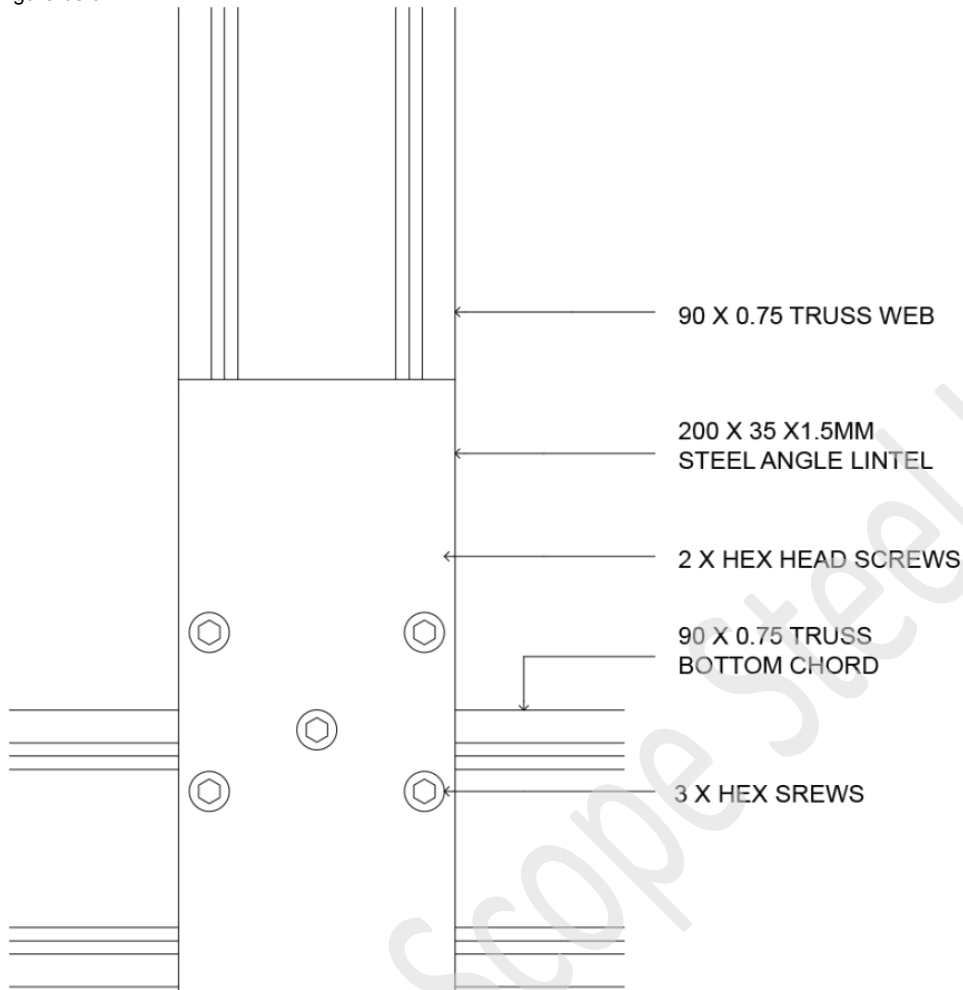
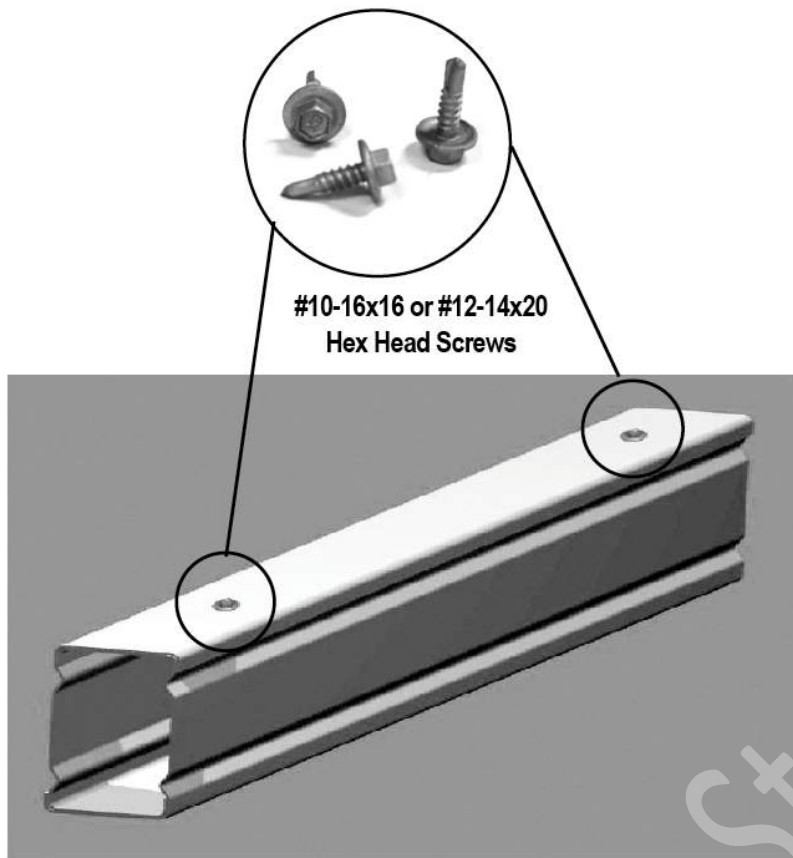

Figure 6.6 - Web stiffener

6.5.6 Chord Boxing

Where called for in the Assembly Sheet, chords are to be boxed using supplied boxing channel. Boxing is to be fixed to the chord using #10-16x16 or #12-14x20 hex head self drilling screws through each flange 50 mm from each end of the boxing and at 600 mm nominal centres along the boxing.



6.5.7 Web Boxing

Where called for in the Assembly Sheet, webs are to be boxed using supplied boxing channel. Boxing is to be fixed to the web using #10 -16x16 or #12-14x20 hex head self drilling screws through each flange 50 mm from each end of the boxing and at the centre of the web.

7.0 Roof construction

7.1 General and design

ENDUROTRUSS® Framing System roof trusses have been designed to engineering standards and it is essential that to perform, as designed, they are handled, erected and braced correctly. The following recommendations apply to roof trusses on standard domestic and light commercial buildings.

The trusses are designed by the ENDUROCAD® design software to suit the specific roof and ceiling geometry and loads applicable site conditions. Additional loading such as Solar Units, Hot Water Tanks, Air Conditioning, etc. require special consideration at the time of design and the placing of these additional loads must be referred back to the designer.

Wind load is an important factor in the design and performance of roof trusses. Ensure that the correct design wind loads have been used and that the tie down of trusses to the wall structure is carried out in accordance with the construction documentation.

7.1.1 Prior to construction

Before commencing roof construction:

1. Check the support structure in particular the plan dimensions, the plumb and level of the support structure, the straightness of the supporting walls or beams and that the structure is adequately braced, stable and tied down. Rectify support structure if found deficient prior to proceeding.
2. Roof trusses must be inspected and any damaged parts must be reported immediately to ensure correct rectification. Approval for site rectification should be obtained from the truss manufacturer.
3. Check that the ENDUROCAD® software generated truss layout matches the building and that all truss set-out dimensions and truss identification marks have been provided.

NOTE:

Truss orientation and Position

The layout drawings specifies the correct truss orientation. **The front of the truss is the flat (unlipped) face of the truss chord. Looking at the truss from this direction identifies the Left and Right hand truss ends.** Ensure trusses are orientated as shown on the truss layout. Trusses must be positioned within 5mm from their specified position.

Roof Truss Numbering

During the detailing / fabrication process the roof trusses are numbered to accurately identify them. These numbers are shown on the roof truss layout and form part of the truss branding (refer Section 6). Trusses may have identical shape but may differ in the web configuration or internal connections. Ensure that the correct truss is used in its specified location on the roof.

Safety

Ensure that all barriers or scaffolding used in order to comply with safe work practices are installed so as not to damage or overload roof components.

7.1.2 Internal load bearing

Where trusses are supported by internal walls, the truss web configuration will be designed to satisfy the load concentration at the load bearing point. Ensure that the truss is installed such that bottom chord to web connections are within 5mm to the support points. The builder should ensure that these loads are accommodated in the foundation design.

7.1.3 Fasteners

Generally for roof construction #12-14x20mm hex head self-drilling Class 3 screws are used for all structural connections. Use the recommended number shown on the drawings.

In connections, maintain a minimum fastener spacing of 17mm and minimum distance of 17mm to the end of sections and a minimum 10mm from the edge. Refer to Section 6.5 for a diagram showing locations.

7.2 Roof truss set-out

Prior to lifting any trusses into place, mark out the truss locations on the top wall plate, using the supplied Roof Framing Layout as a reference. The trusses may be aligned to load bearing studs. In cases where it is not aligned, sufficient capacity shall be provided for top plate using lintels or stiffeners. Check that design truss spacings have not been exceeded.

If trusses are fixed to the support structure using brackets these are often installed in the marked positions prior to positioning the trusses.

Alternatively service holes may be punched in the top plate above studs to which trusses are to be fixed. These service holes are to act as location points and allow a 25 x 3 x 200mm tie down strap to fit through and fix to the face of the stud.

It is generally best practice to install Girder trusses and Hip ends before proceeding with the installation of standard truss runs.

Whilst erecting roof trusses ensure that each truss is erected in the correct position, correctly orientated with chords aligned with the roof slopes and plumb (using a spirit level).

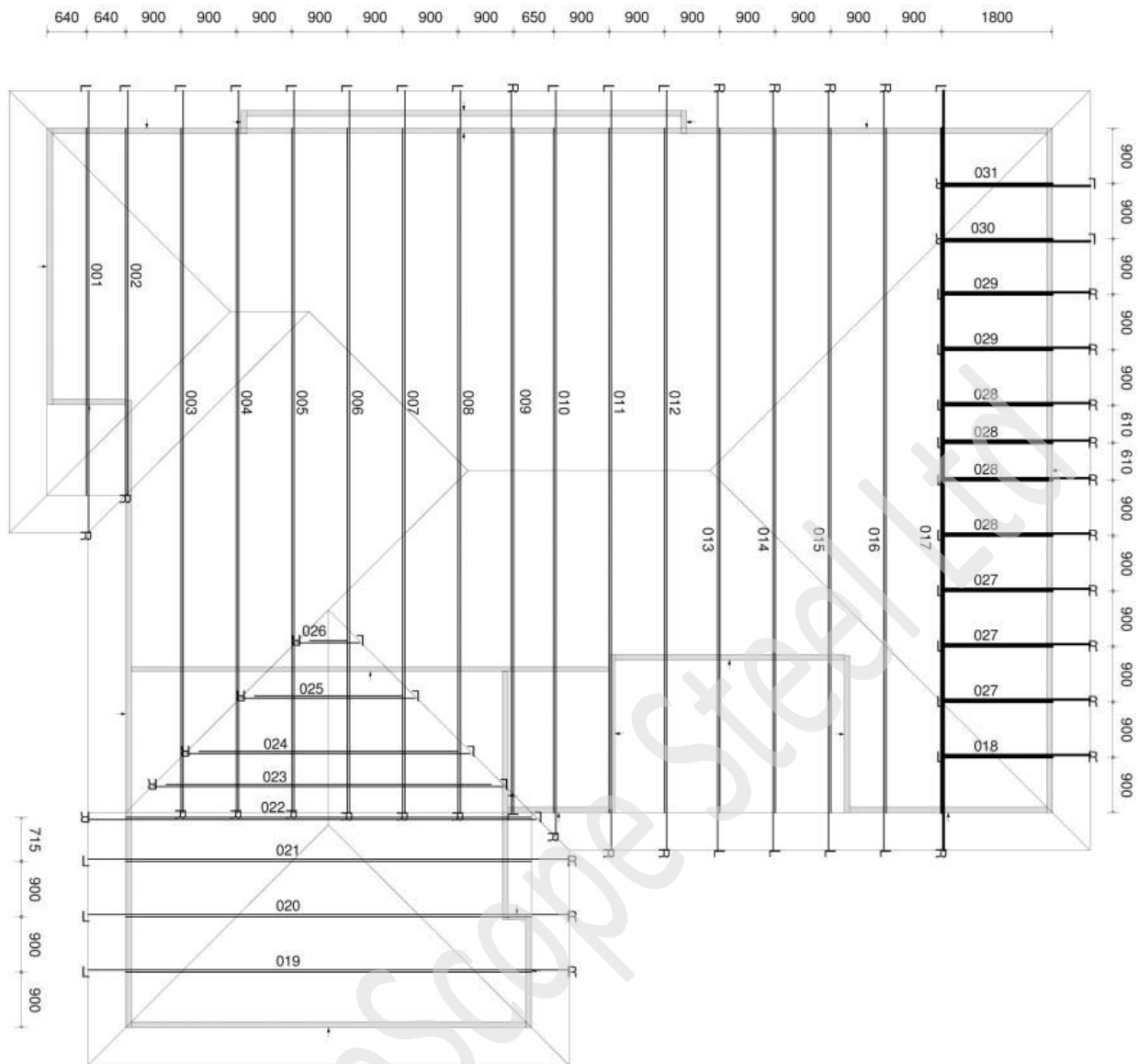

Figure 7.1 Truss layout drawing as generated by ENDUROCADD®

7.3 Gable End Construction

There are essentially three types of gable ends though some variations may be utilised with different wall and roof cladding types.

End support may be provided by using a gable end truss or by extending the end wall to the roof plane for batten support.

Where a gable end truss is used it is usually positioned just inside the end wall where the ceiling battens may be fixed directly to the truss bottom chord. Framing members are attached directly to the truss outside face to support the wall cladding. These framing members may consist of battens or wall studs and must be designed to span between the ceiling plane and the roof plane. Temporary bracing should be employed to maintain stability during erection. Ensure the truss is installed plumb and correctly positioned so that the external cladding line is maintained. Refer to Section 7.9.1 for temporary bracing.

If the gable end wall is extended to the roof plane to provide wall cladding support, the studs must be designed to span from floor to roof. If there is a ceiling plane below the roof plane then the studs must be fixed so as to transfer end wall wind loads into the ceiling plane. Refer Fig. 7.2 for connection details.

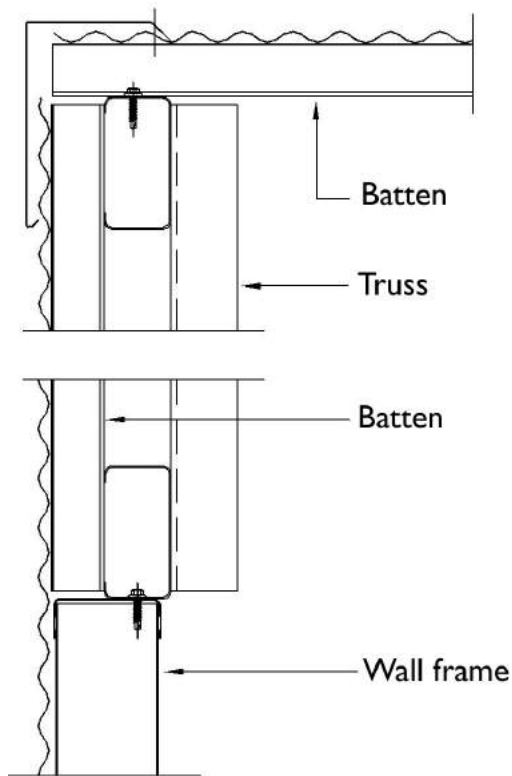

Figure 7.2 Connection detail

Type 1 Flush Gable

For flush gables, roof battens and end wall claddings are directly supported by a raked end wall or a truss fitted with cladding support members. Refer Fig 7.3.

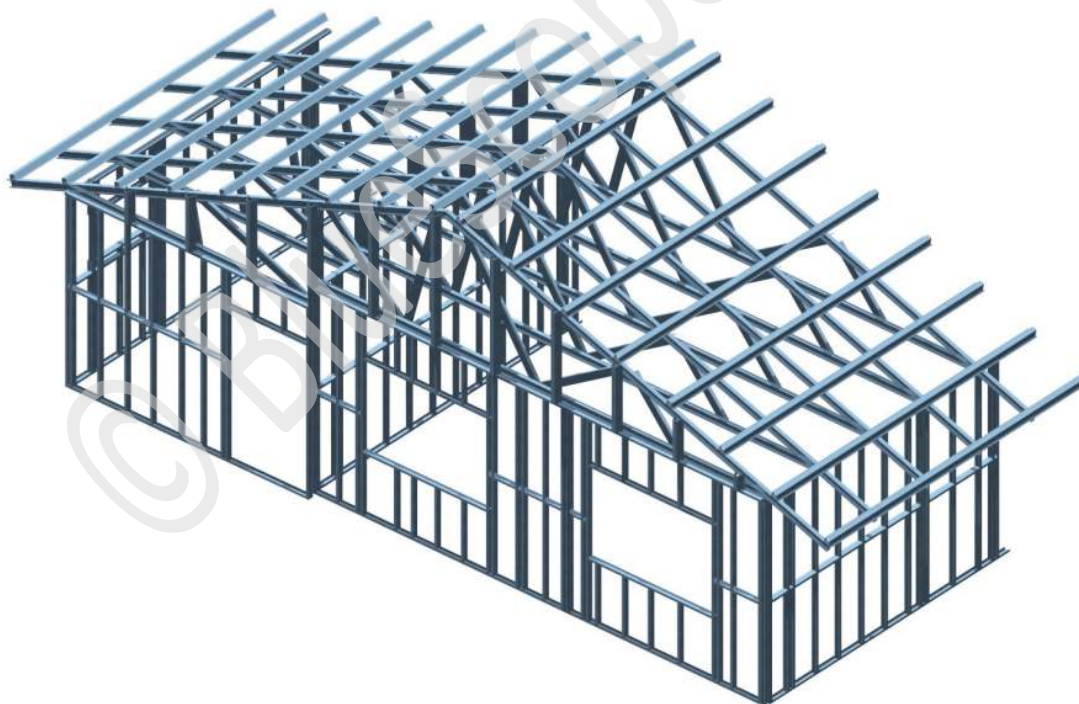

Figure 7.3 Framing and truss configuration for a flush gable

Type 2 Small Verge

In non-cyclonic areas where verges are less than 450 mm, support can generally be provided by the battens as shown in Fig 7.4 and 7.5. A Gable ladder manufactured from wall framing stud and plate is installed under the batten projections to carry the soffit linings, barge fascia and flashings. Where specified, additional ladder support can be provided by doubling the roof battens one truss bay into the roof or by providing structural members such as channels or RHS in lieu of batten support.

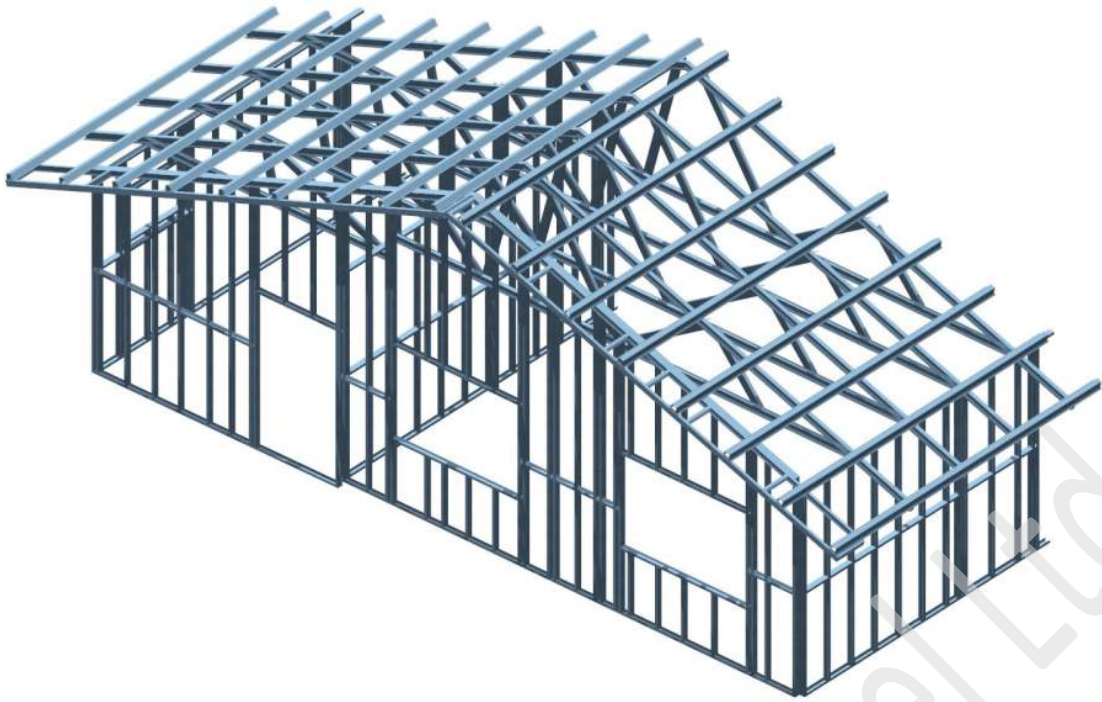

Figure 7.4a Small verge, supported by wall framing

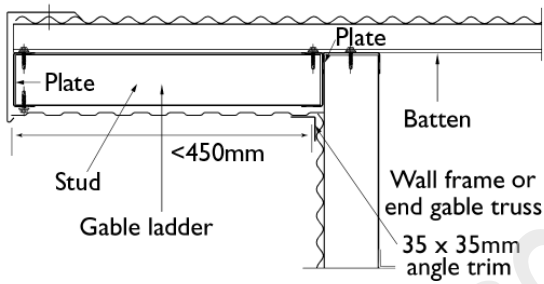

Figure 7.4b Connection detail

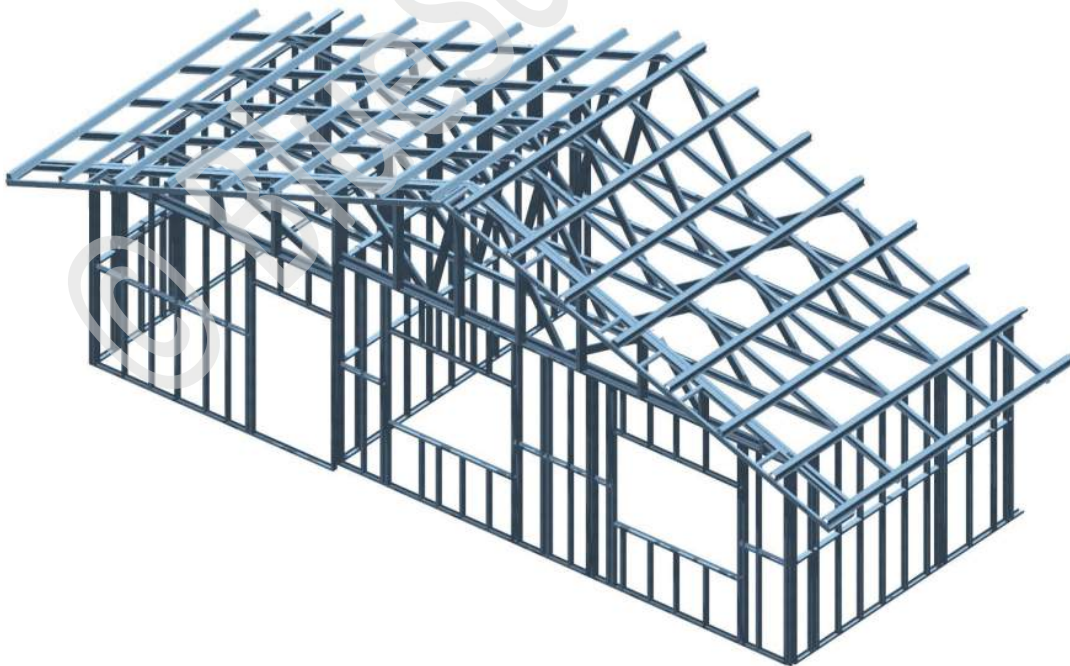

Figure 7.5 Small verge, supported by gable end truss

Type 3 Large verge overhangs

Where insufficient verge support is offered by battens or structural members a Type 3 gable end may be required. Here the end wall is extended below the roof plane enabling a verge ladder to be fixed to the first truss back from the gable end and connected to the gable end wall top plate and cantilevering to form the verge framing as shown in Figure 7.6a. The gable ladder must be designed to suit the load condition, the cladding material and the verge overhang.

For a 75 x 1.0mm or 90 x 1.0mm ladder frame supporting sheet metal cladding, a maximum verge overhang of 900mm is acceptable in non-cyclonic areas using verge framing members at 1200 max centres, and 600mm is acceptable in cyclonic areas using verge framing members at 900mm max centres.

For a tile roof a maximum overhang of 600mm is permitted in non-cyclonic areas only. Larger overhangs can be achieved by modifying the ladder and should be referred to an engineer.

The steps are as follows:-

STEP 1: Study the entire set of architectural and fabrication drawings.

STEP 2: Erect gable trusses in accordance with Section 7.3.

STEP 3: Install gable ladders for small verges by fixing each batten to both gable ladder plates using 1 #12-14x20 screw per batten flange. For large verges, the gable ladder is aligned with the top chord and cantilevers over the end gable wall (or truss).

STEP 4: Fix the gable ladder to the truss or gable end wall using 2 #12-14x20 hex head screws at 1200mm centers for non-cyclonic areas and 900mm centres for cyclonic areas.

STEP 5: Fix battens to the end truss or gable end wall (where extended to the roof plane) and the gable ladder at the verge projection.



Figure 7.6a Large verge overhangs

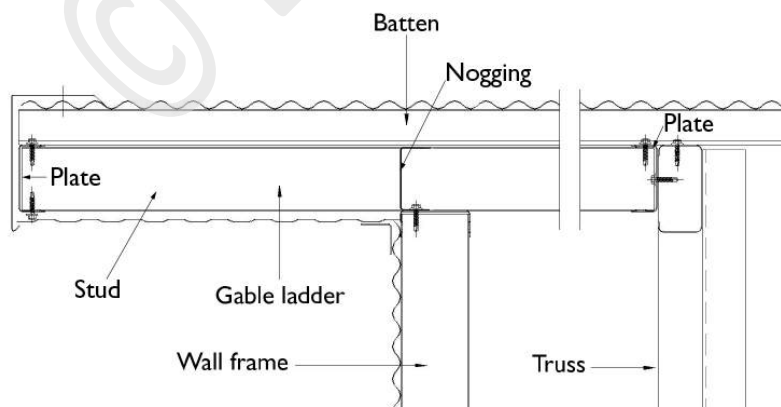

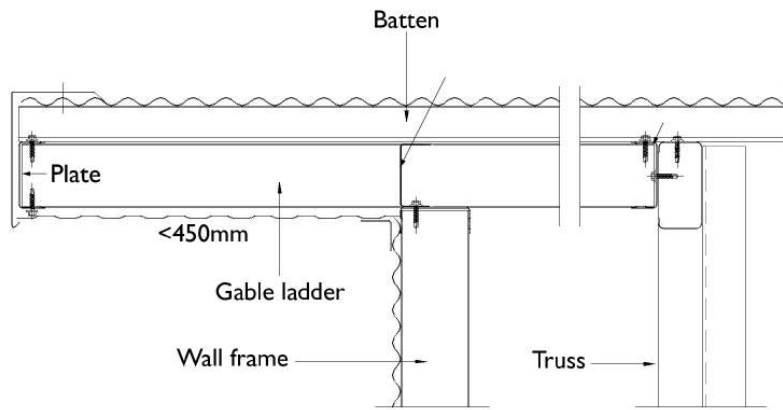

Figure 7.6b Connection detail

7.4 Hip End Construction

Three options are available for hip end construction: Type 1, Type 1A and Type 2. Each option has different configurations for trusses and rafters although the general assembly method is the same. There are also 2 options for hip rafter construction which can be used with each of the hip end and rafter construction methods. A description of these hip end construction options and how they are installed is described in Sections 7.4.1, 7.4.2 and 7.4.3.

There are 2 types of hip rafter construction which can be used with any type of hip end construction: a Vee plate and a boxed hip rafter. A Veed hip rafter is a pre-manufactured piece which extends back to the second truncated truss. The creeper rafters are pre-attached to the Veed hip rafter and support the fascia. There is a left and a right side with the longer rafter aligned with the bent notch on the horn of the truncated truss.

A boxed hip rafter extends up the length of the hip line and consists of 2 pieces of truss section boxed together.



Veed Hip rafter

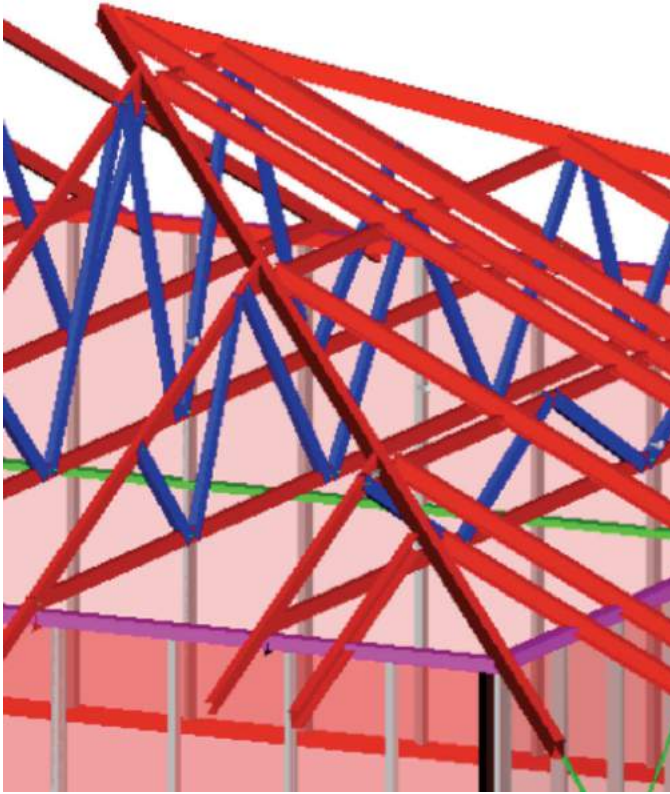

Boxed hip rafter

Below is a summary of the details to use to fix hip rafters::

	Non Cyclonic Tile Sheet	Cyclonic Sheet
Hip rafter to wall – boxed hip	7.7, 7.8, 7.17a & 7.22a	
Hip rafter to wall – Veed rafter	7.10	7.9
Hip rafter to truncated truss – boxed hip	7.11	
Hip rafter to truncated truss – Veed rafter	7.14	7.9
Creeper/Common rafter to top plate	7.18 - 7.20	7.20 & 7.21
Creeper/Common rafter to truncated truss top chord	7.13 - 7.15	7.17

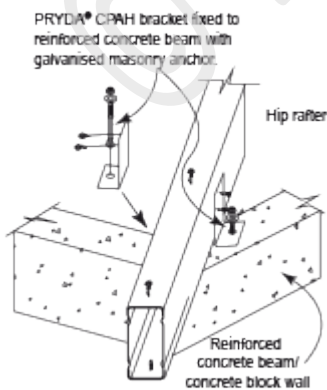

Figure 7.7 Pryda CPAH bracket

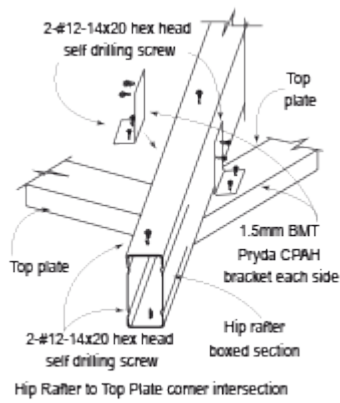

Figure 7.8 Hip rafter to top plate corner intersection

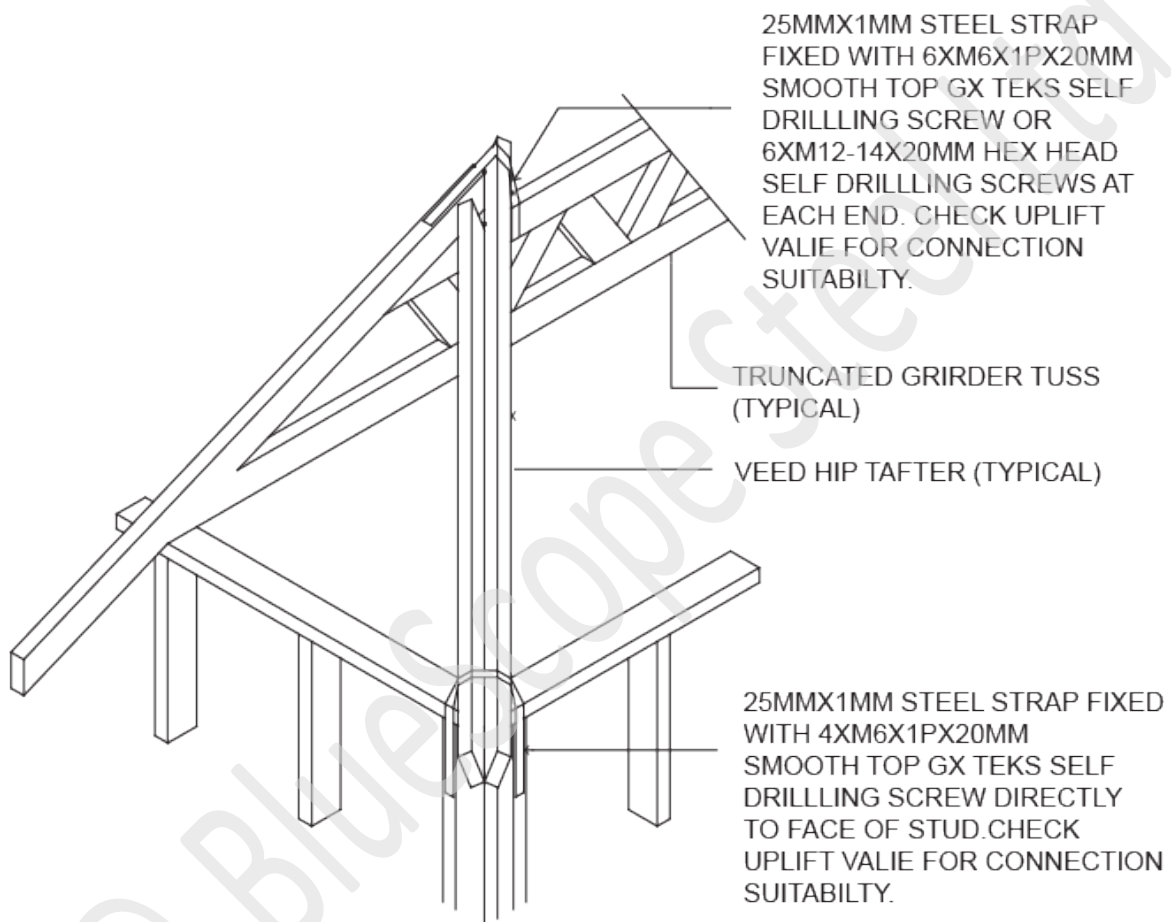

Figure 7.9 Veed hip rafter to wall and truncated truss – cyclonic

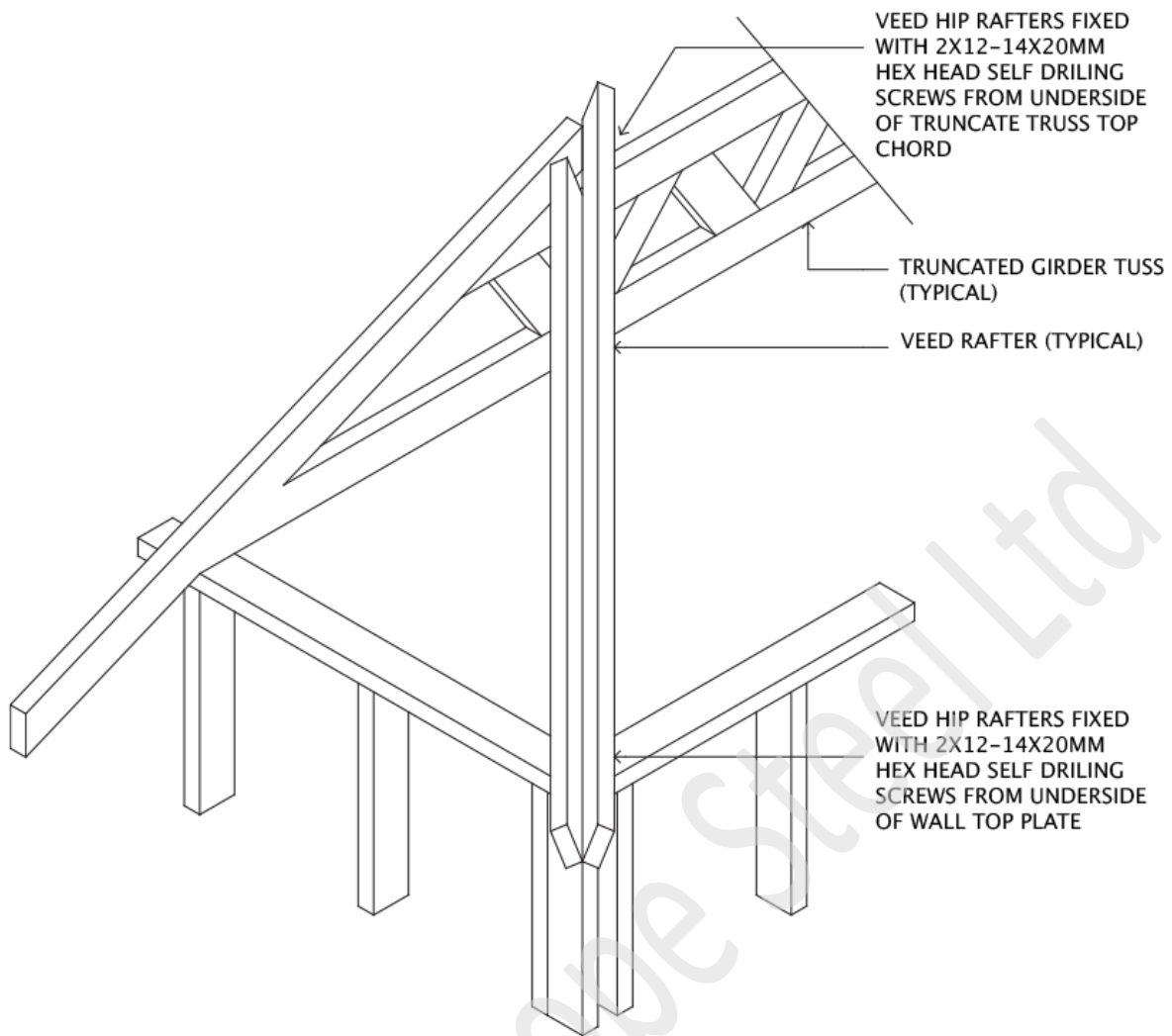

Figure 7.10 Veed common rafter hip

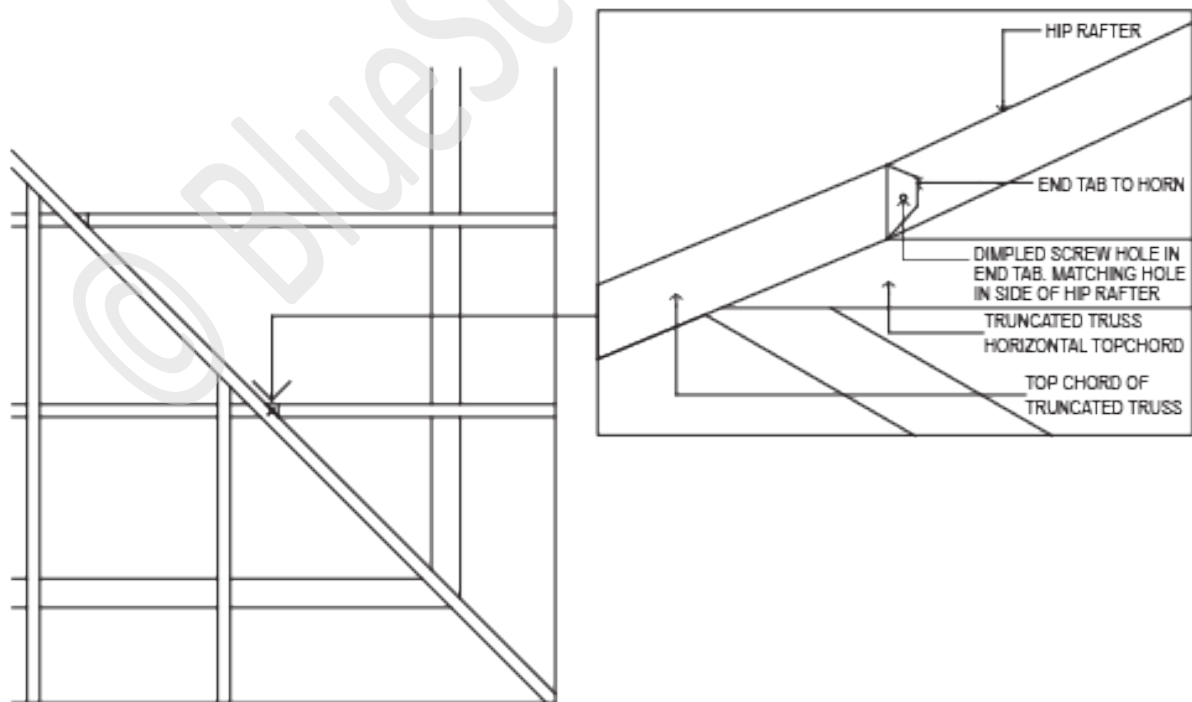
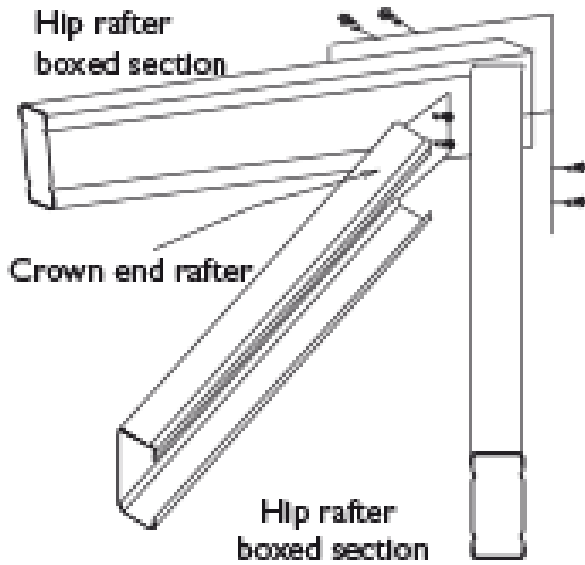

Figure 7.11 Boxed hip rafter

'L' bracket 1.0mm BMT fixed to rafter and top plate with 4 #12-12x20 hex head screws



Crown End Rafter to Hip Rafter

Figure 7.12 Crown end rafter to hip rafter

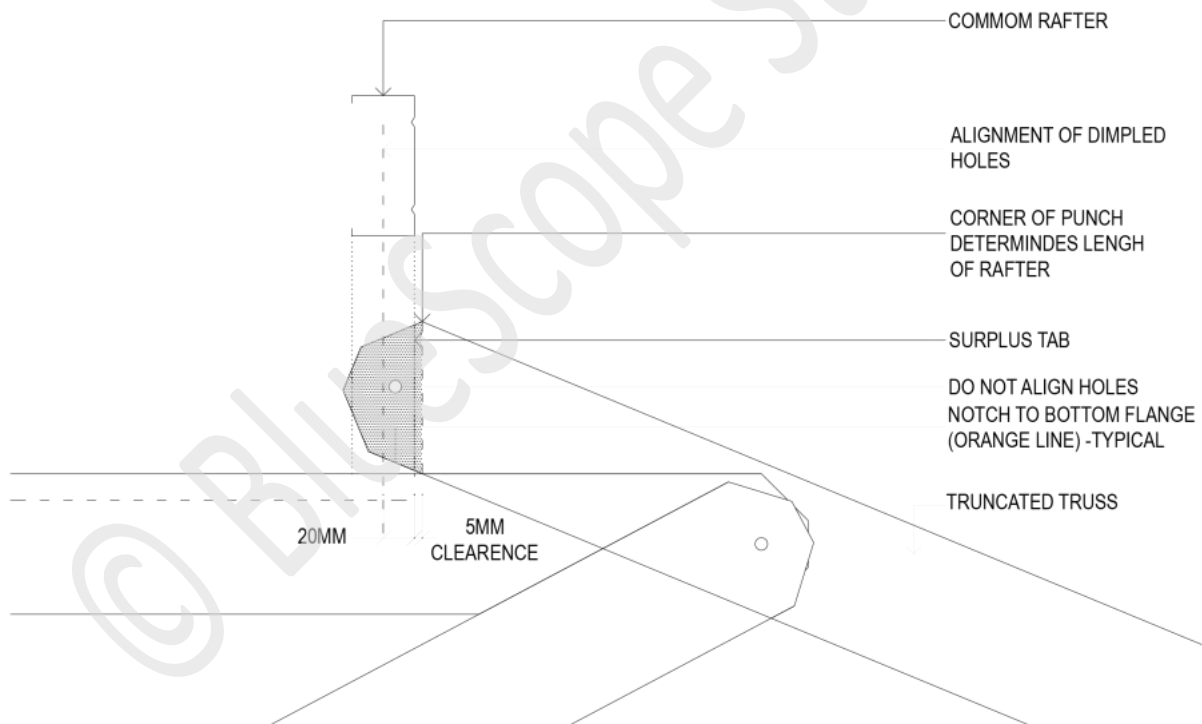

Figure 7.13 Common rafter to truncated truss at hip

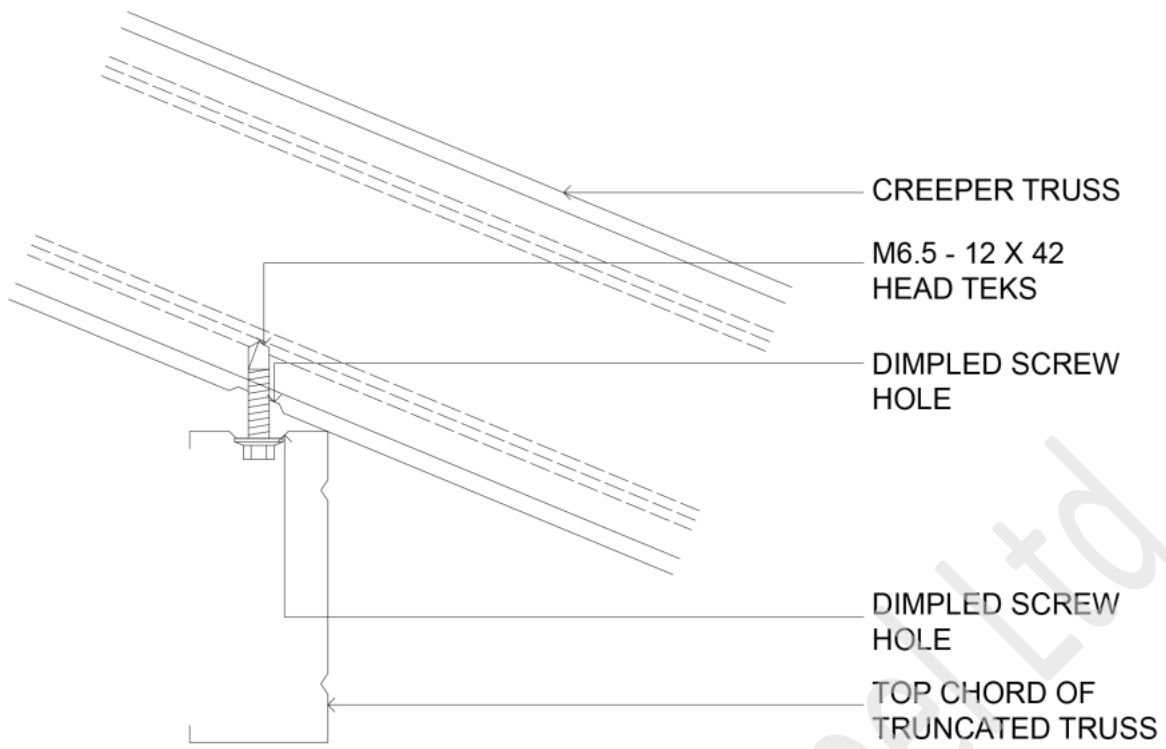

Figure 7.14 Common rafter to truncated truss

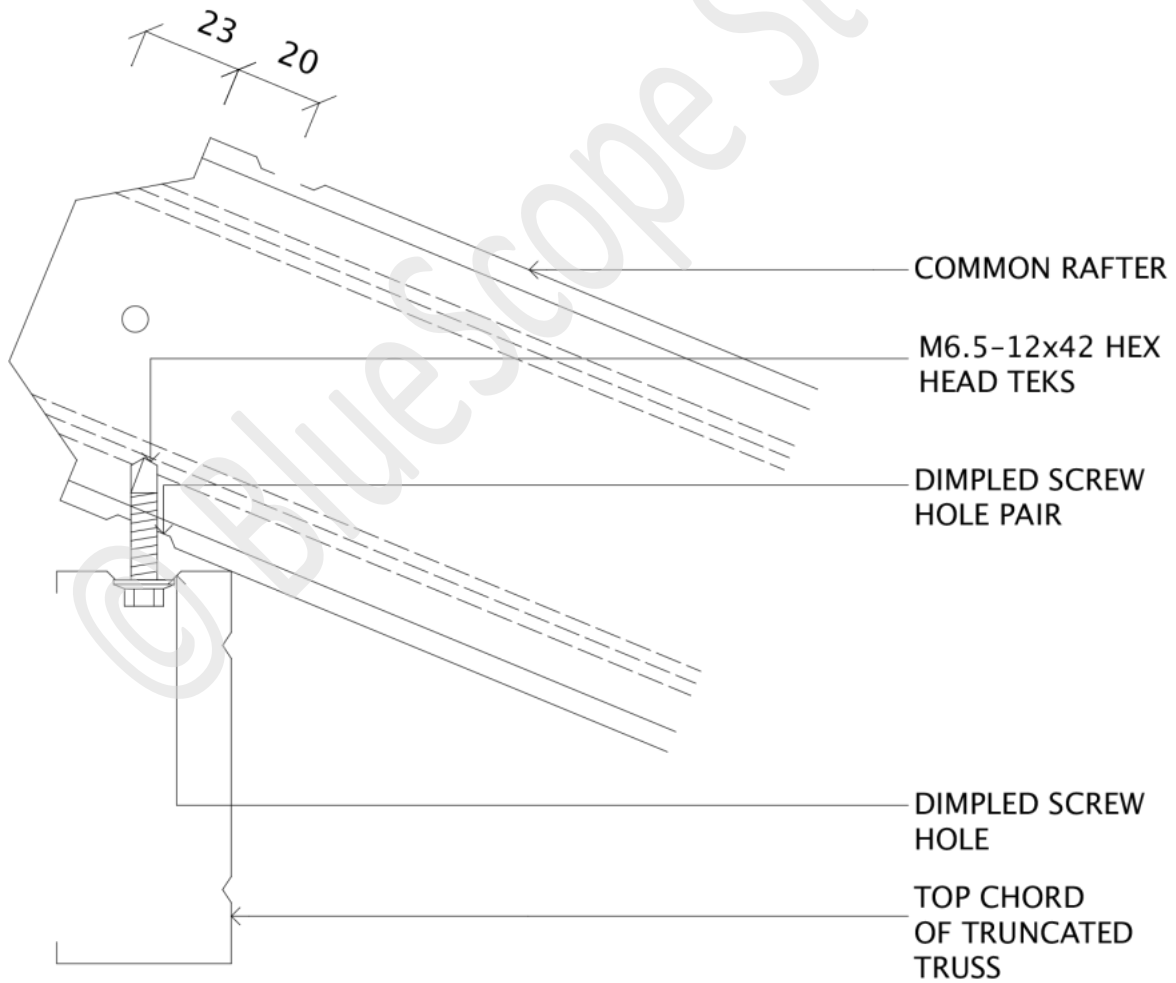

Figure 7.15 Common rafter to truncated top chord end

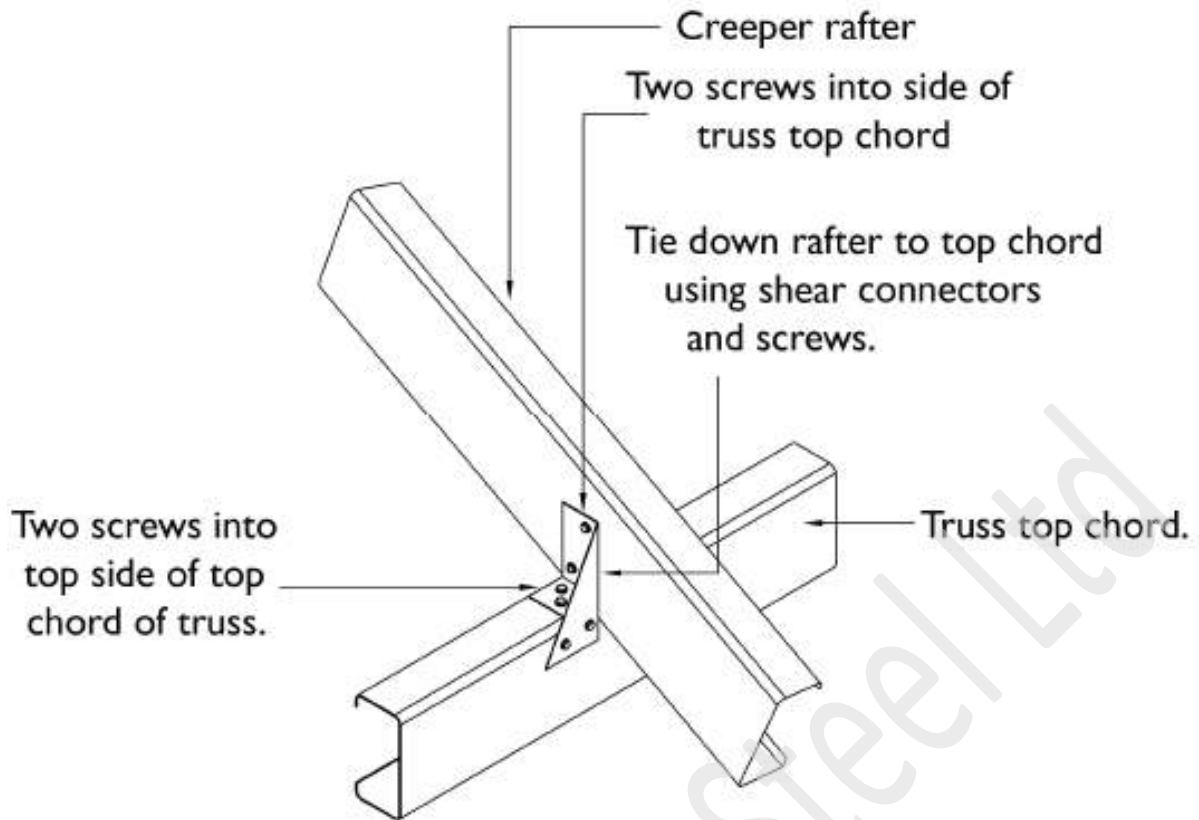

Figure 7.17 Common Rafter to truss top chord using shear connectors. Trip-L-grip shown but Multi-grip or angle may also be used

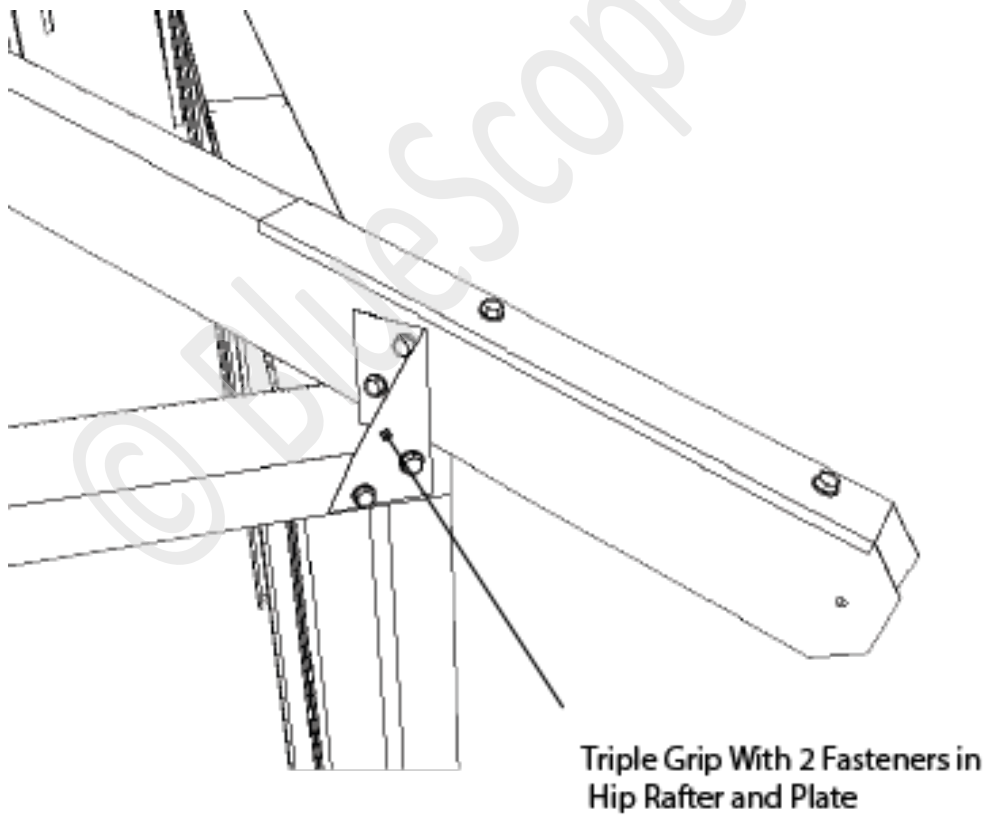

Figure 7.17a Hip rafter tie down using Triple grips. For boxed member option

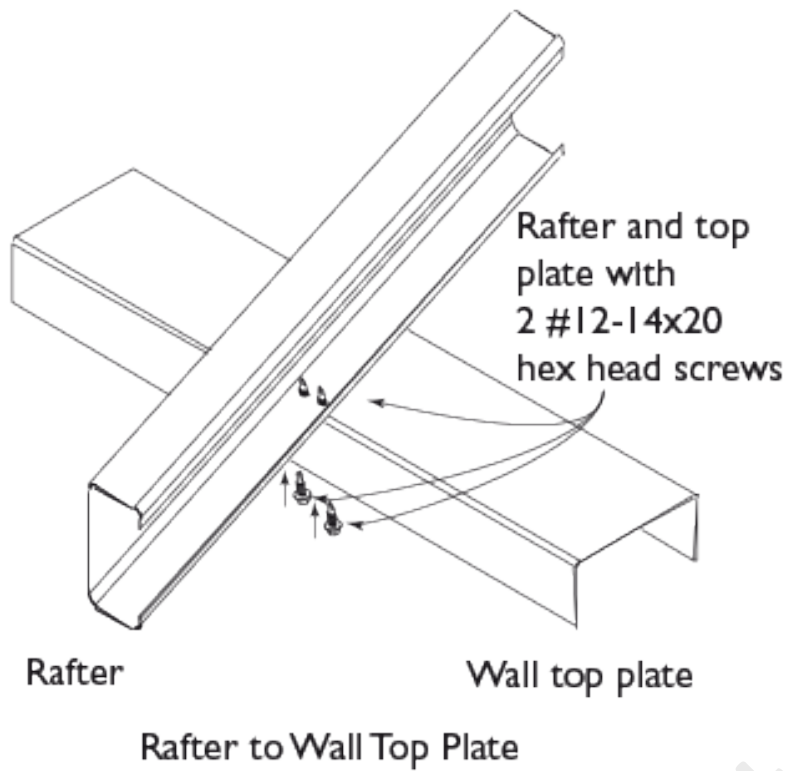

Figure 7.18 Common Rafter/creeper rafter to wall top plate using screws

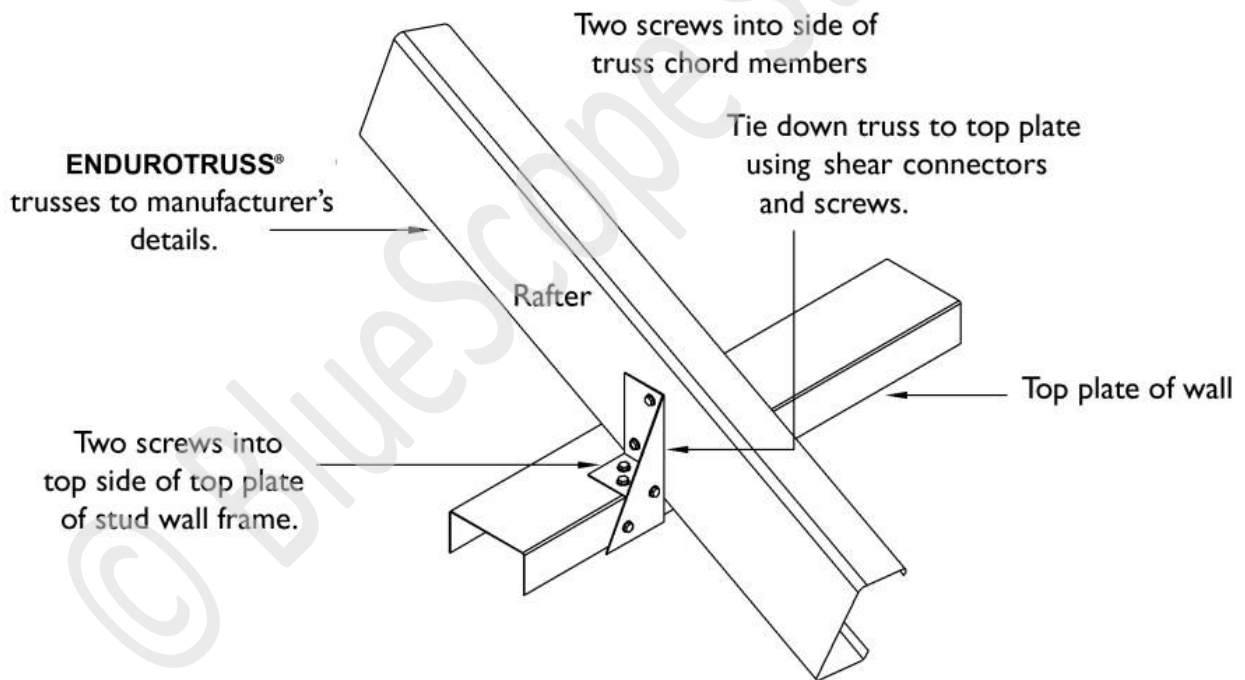

Figure 7.19 Rafter to wall top plate using Pryda® Triple-Grip shear connector

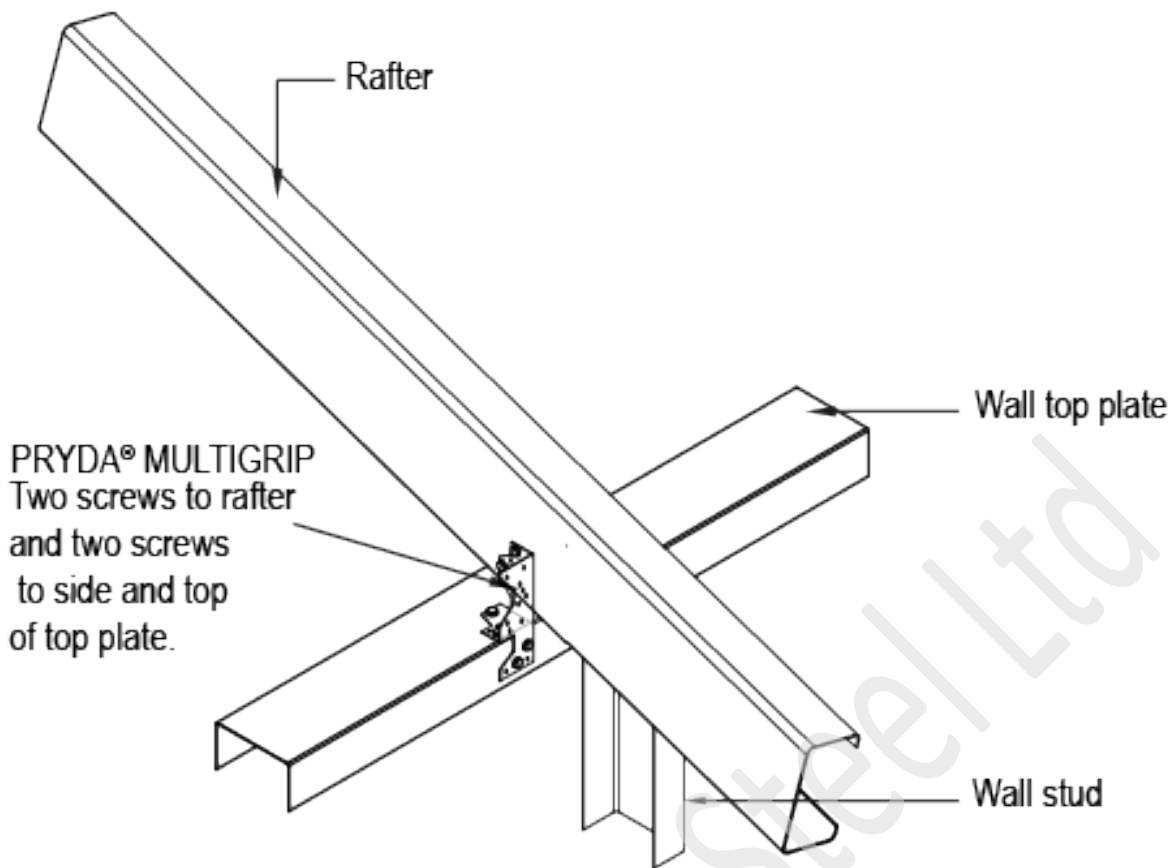

Figure 7.20 Rafter to wall top plate using Pryda® Multi-Grip Plate transition bracket may also be used as shown in Fig. 7.2.2b

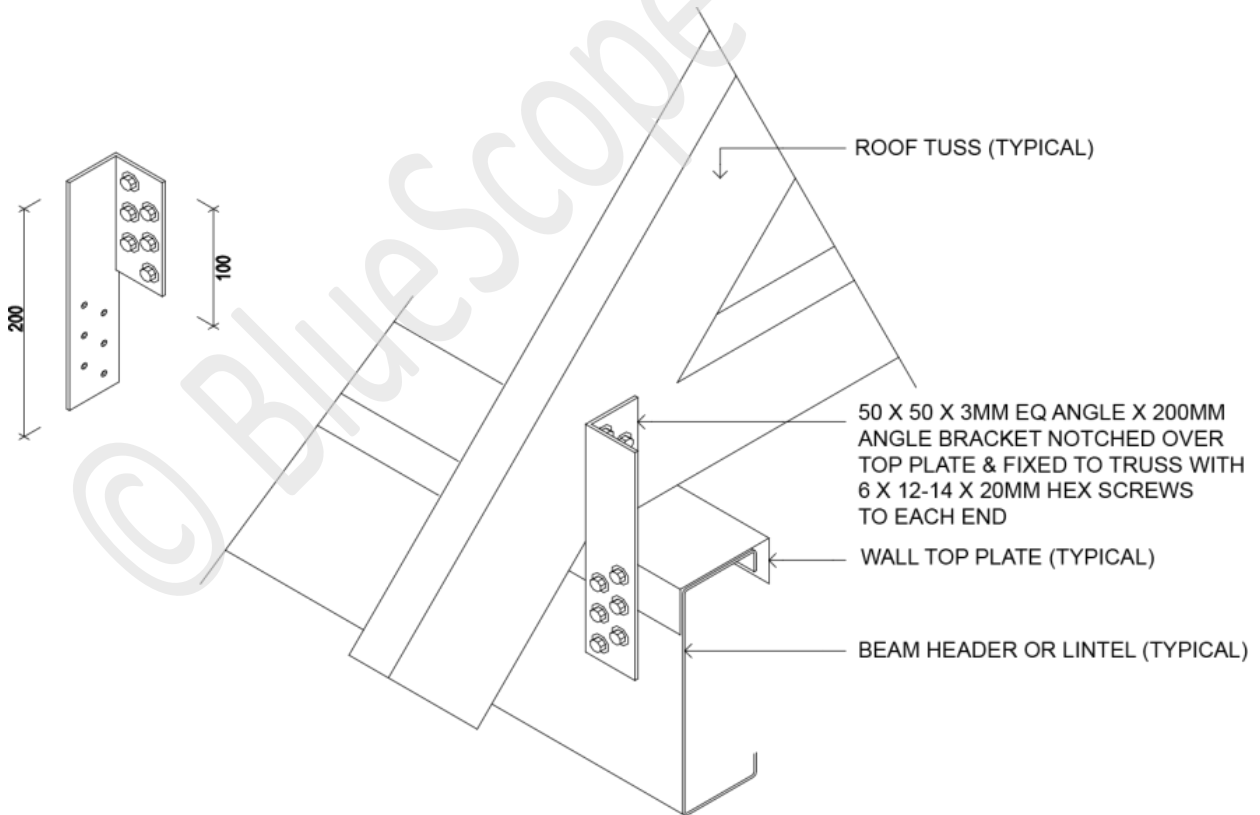

Figure 7.21 Common rafter top plate

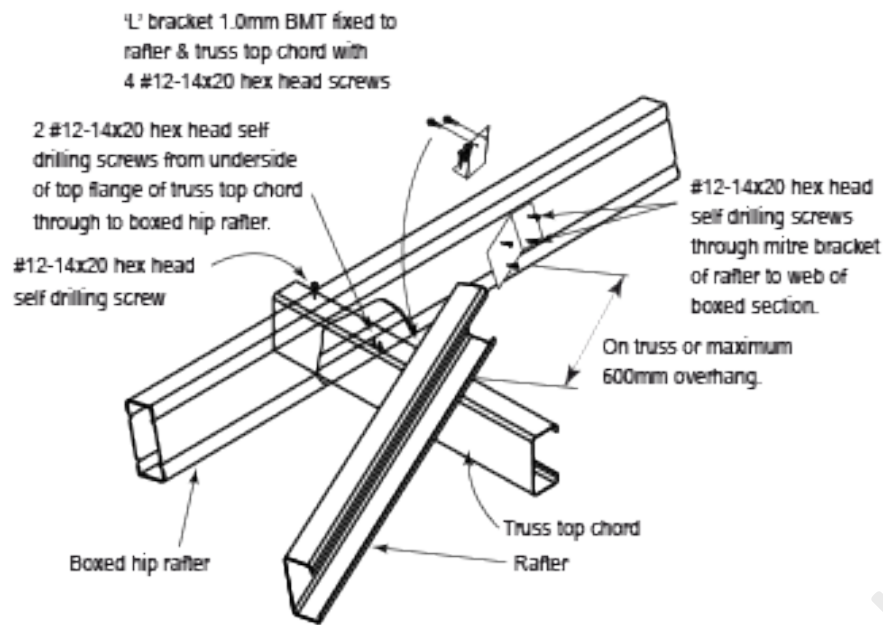

Figure 7.22 Hip/creeper rafter connection

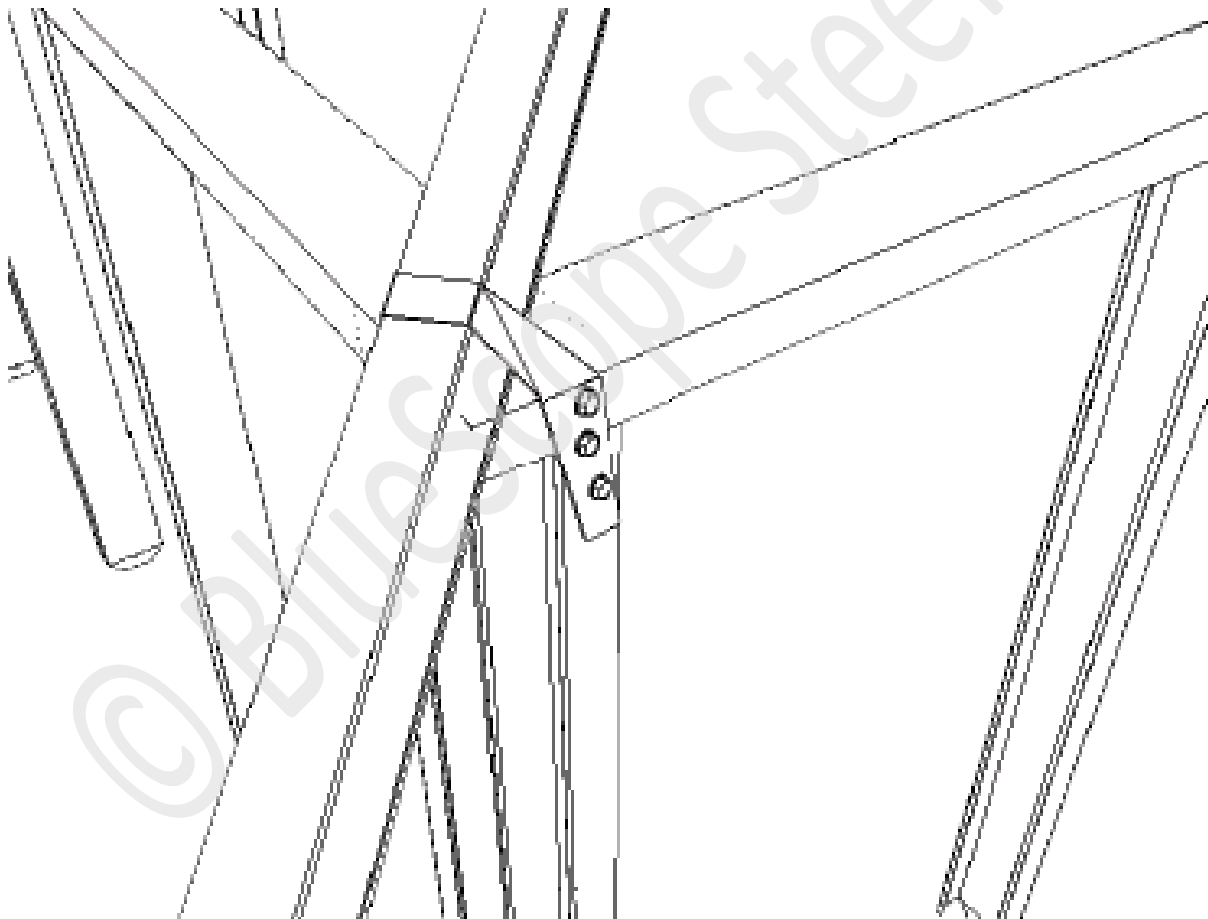

Figure 7.22a Hip rafter tie down using 1.2 x 30mm strap over hip rafter attached with 3x12-14x20 hex head fasteners

7.4.1 Type 1 Hip construction

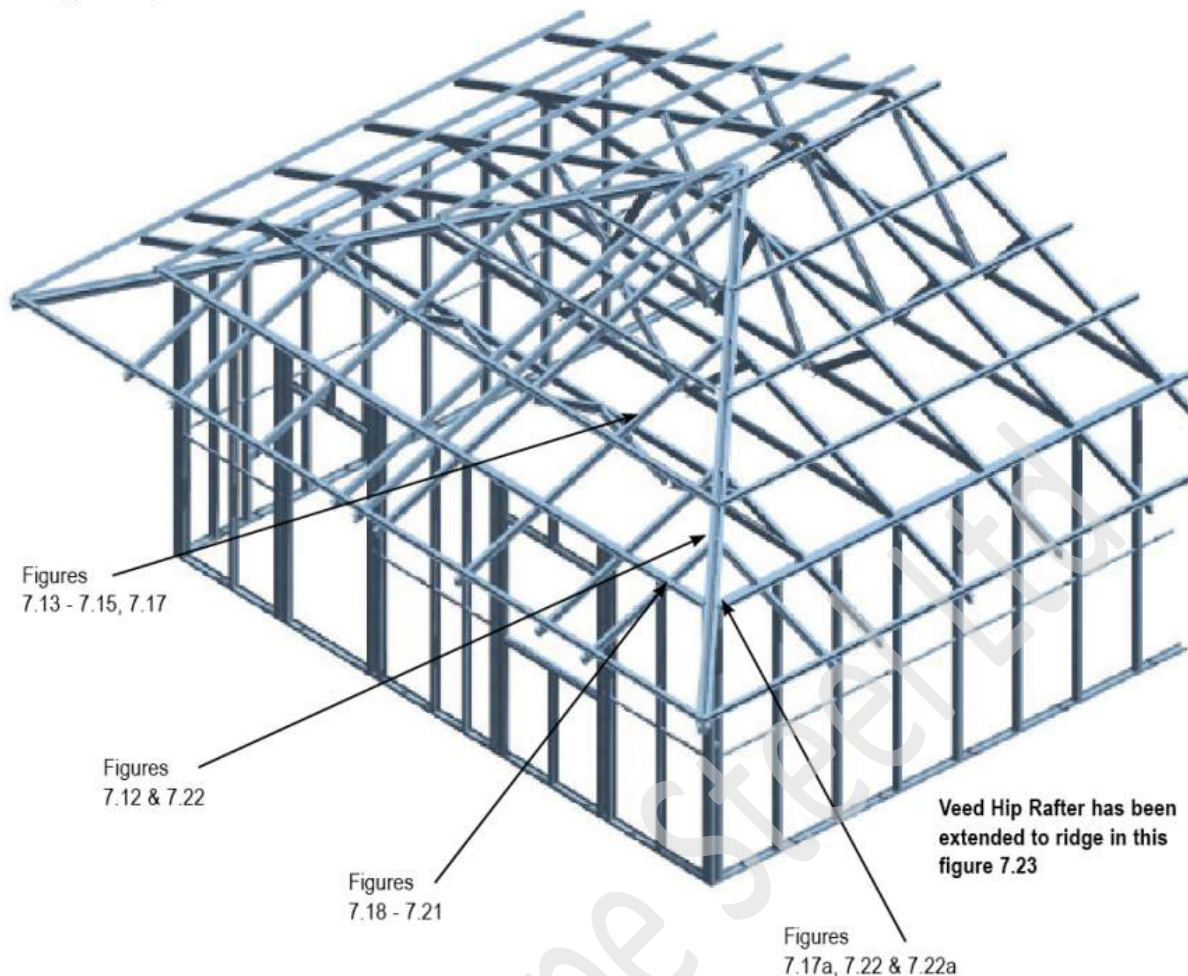

Figure 7.23 Type 1 hip construction

Standard ENDUROTRUSS® Framing System hip end trusses (Type 1 Hips) are generally placed parallel to and at the same spacing as the main roof trusses. The following procedures apply to Type 1 Hip Roof construction.

STEP 1: Study the entire set of architectural and fabrication drawings.

STEP 2: Set out and mark truss positions as per Section 7.2.

STEP 3: Install fixing brackets to support structure in marked positions.

STEP 4: Lift trusses into position, ensuring the webs of the trusses face the hip end wall.

STEP 5: Stand the first station truncated truss in its set-out position and, fix two #12-14x20mm hex head self drilling screws through the fixing bracket at each heel connection into the truss Chord. If erection screw positions clash with truss manufacture fasteners remove these screws and replace with the erection screws through the bracket and into the chords in the same location.

STEP 6: Temporarily brace the truss and ensure it is plumb and straight. This can be done using batten or roof bracing material fixed to the end wall and to the horizontal top chord of the truss.

STEP 7: Repeat Steps 3 and 4 when installing the second, third and subsequent station truncated trusses until all truncated trusses are positioned in accordance with the roof layout.

STEP 8: Hip rafters are provided at hip ends to support roof battens and creeper rafters. There are 3 types of hip rafter options available in the ENDUROTRUSS® system. Note that the trusses will align with the top chords of the truncated trusses via dimple holes that are punched in both the rafters and truncated trusses.

A Boxed Hip Rafter extends from the fascia corner at the eaves to the end of the hip line. It may be fixed to another hip rafter as shown in Fig. 7.12. Depending on the cladding material and wind loads the fixings of the hip rafter may vary. For tile roofs, 2 screws are placed through the truncated top chord into the hip rafter as shown in Fig. 7.14 & 7.15. For bottom of hip rafter, a shear connector is used as shown in Fig. 7.19 and Fig. 7.20.

A Veed Plate Hip Rafter do not continue to the ridge line. The inner channel of the Vee extends from the fascia line to just past first structural truss. The outer channel of the Vee stops short of the first structural truss so that it does not clash with any members of this truss such as the horn, and can be supplied as a standard part. The hip rafters are fixed with 2 #12-14x20 hex head screws from underside of wall top plate through the hip rafter flange.

STEP 9: Creeper rafters are generally designed to extend from the top chord of the truncated truss adjacent to the knee connection, to the fascia line running perpendicular to the truss. Mark the overhang length on the jack rafters using the truss overhang as a

reference. Position the rafter with the correct overhang and in the location shown on the layout. Ensure the common truss spacing is not exceeded in setting the rafter positions. Fix to the truss top chords 7.13 to 7.15 and the external wall top plate in accordance with Figs. 7.18 to 7.21. Continue to install all creeper rafters until the hip end is complete.

STEP 10: Creeper rafters are supported by the hip rafter and the external wall. They are generally short rafters near the corner of the building. Ensure sufficient back span is provided to give the installed rafter sufficient strength. Mark the overhang length on the creeper rafters as per the jack rafters. Install the creeper rafters in the locations shown on the layout drawing fixing to the creeper rafter and the wall top plates as shown in Fig. 7.18 to 7.21. Fix creeper rafter to hip rafter as shown in Fig. 7.10 to 7.22.

NOTE: When all trusses are erected, install wind bracing as specified in Section 7.9 Roof Bracing.

7.4.2 Type 1A Hip construction

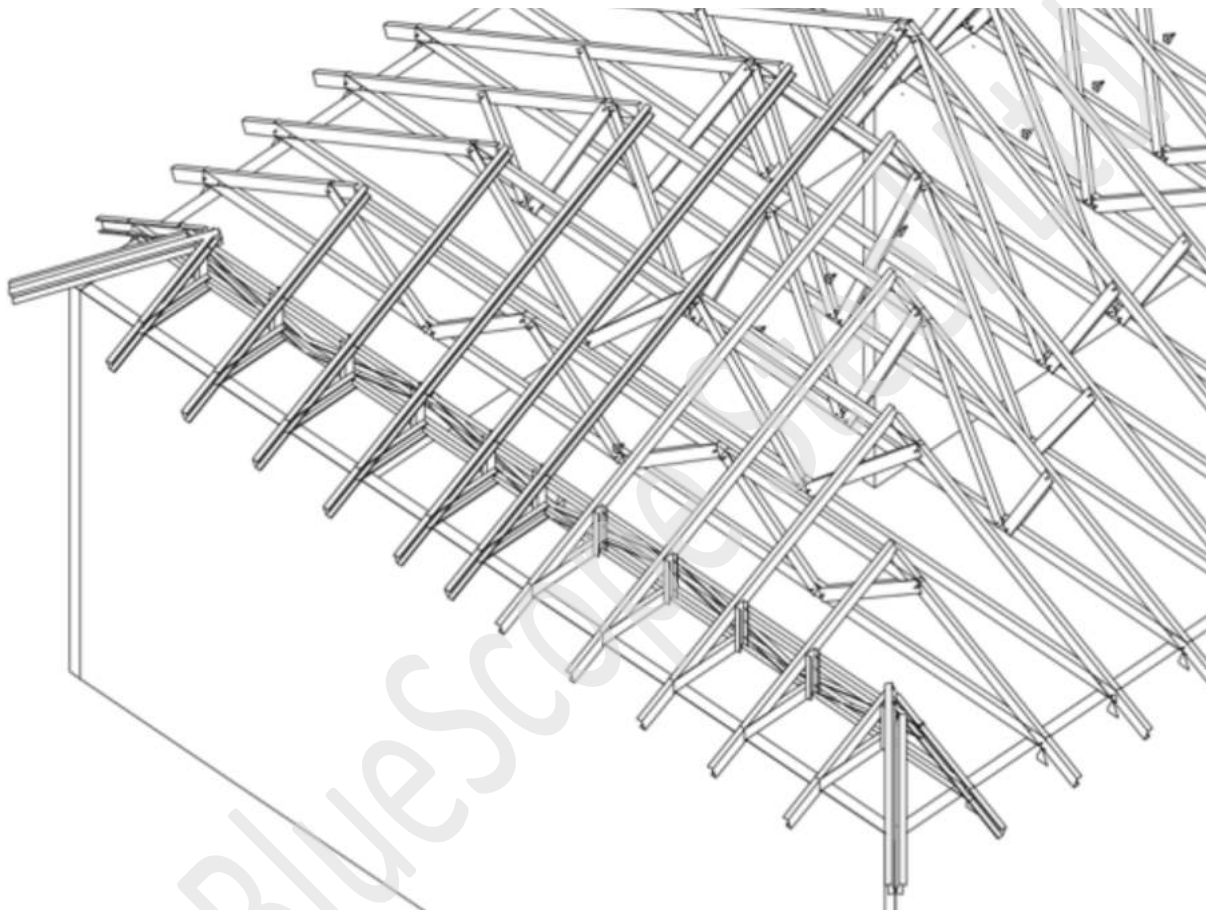

Figure 7.24 Type 1a hip construction

Type 1A is a variation on the Type 1 Hip. The truss layout and design is identical to the Type 1 Hip however the rafters are triangulated between the first station truss and the hip end wall by the addition of a horizontal and vertical member.

Each rafter is thus a simple truss with an extended top chord as shown in Figure 7.24, creating a hybrid of a Type 1 and Type 2 hip.

The purpose of these members is to plumb the first station truncated truss, simplify erection and enable simple installation of rafters where the pitching line is outside the support wall. There is no structural design done on the rafter, ie. it is not treated as a truss and the load distribution on the truncated trusses is treated the same as a Type 1 truss. The rafter assembly utilises SMART technology with assembly using truss assembly screws through pre-punched holes. Assembly is similar to a Type 1 Hip.



Figure 7.24a Installation of a Type 1A hip truss

7.4.3 Type 2 Hip Construction

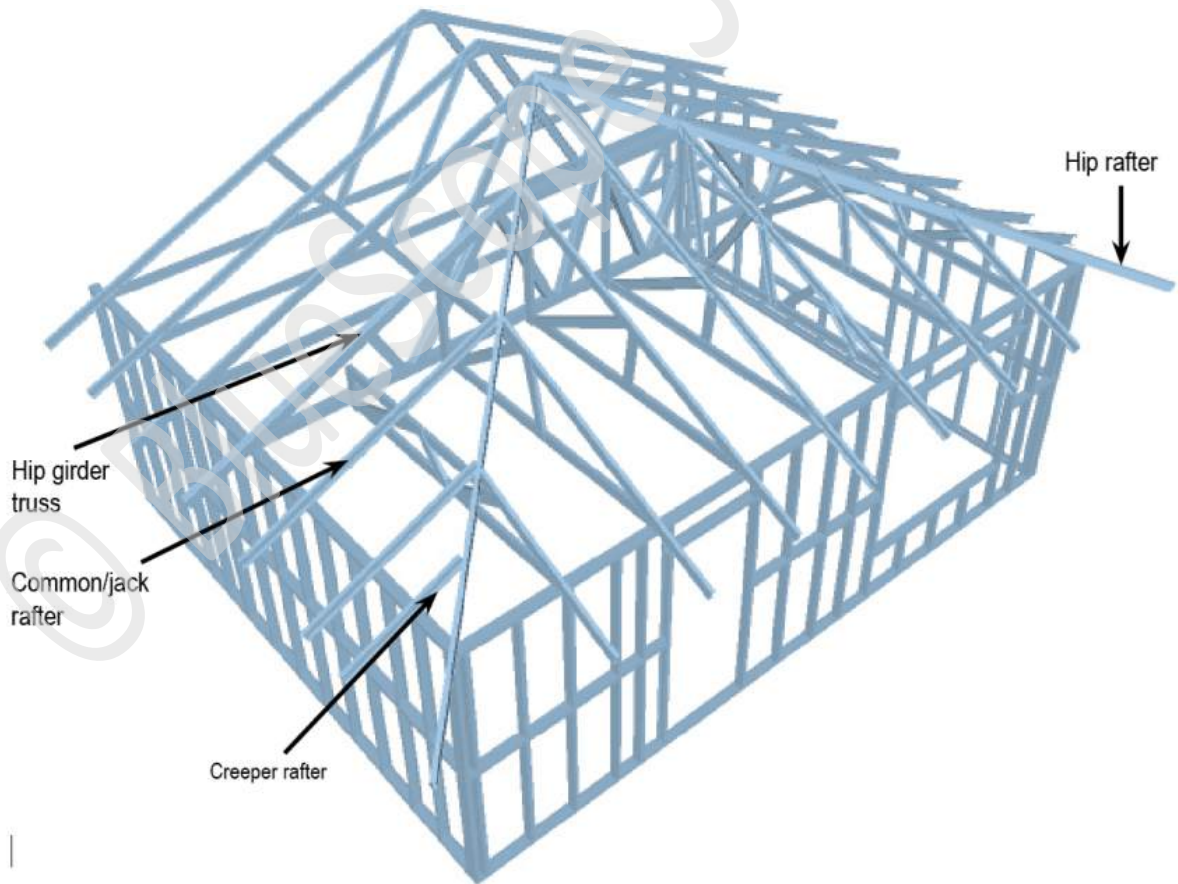

Figure 7.25 Type 2 hip construction

A hip end Girder truss on some large span roofs may be selected. These trusses run parallel to the main roof trusses and pitch half trusses or rafters off this Hip Girder. This is called a Type 2 Hip. The following procedures apply to Type 2 Hip roof construction.

STEP 1: Study the entire set of architectural and fabrication drawings.

STEP 2: Set out and mark truss position as per Section 7.2. Mark Bridge Truss positions on the Hip Girder Truss bottom chord. If the hip girder is a double truss, ensure that the bridge truss location is marked on the correct truss as specified in the girder truss fabrication sheet.

STEP 3: Install fixing brackets to the wall top plates to fix girders, bridge trusses and rafters in marked positions.

STEP 4: Lift girder trusses into position. Note the bottom chord of the Girder trusses is always boxed and that the flat face of the girder faces the hip end wall. If the hip girder is a double truss, install the first ply of the girder truss that is closest to the hip end wall.

STEP 5: Stand the hip girder trusses in its set-out position and fix two #12-14x20mm hex head self drilling screws through the fixing bracket at each heel connection into the truss chord. If erection screw connection clash with truss manufacturer fasteners, remove these screws and replace with the erection screws through the bracket and into the chords in the same location.

STEP 6: Temporarily brace the trusses and ensure that they are plumb and straight. This can be done using batten or roof bracing material fixed to the end wall and to the Horizontal top chord of the truss.

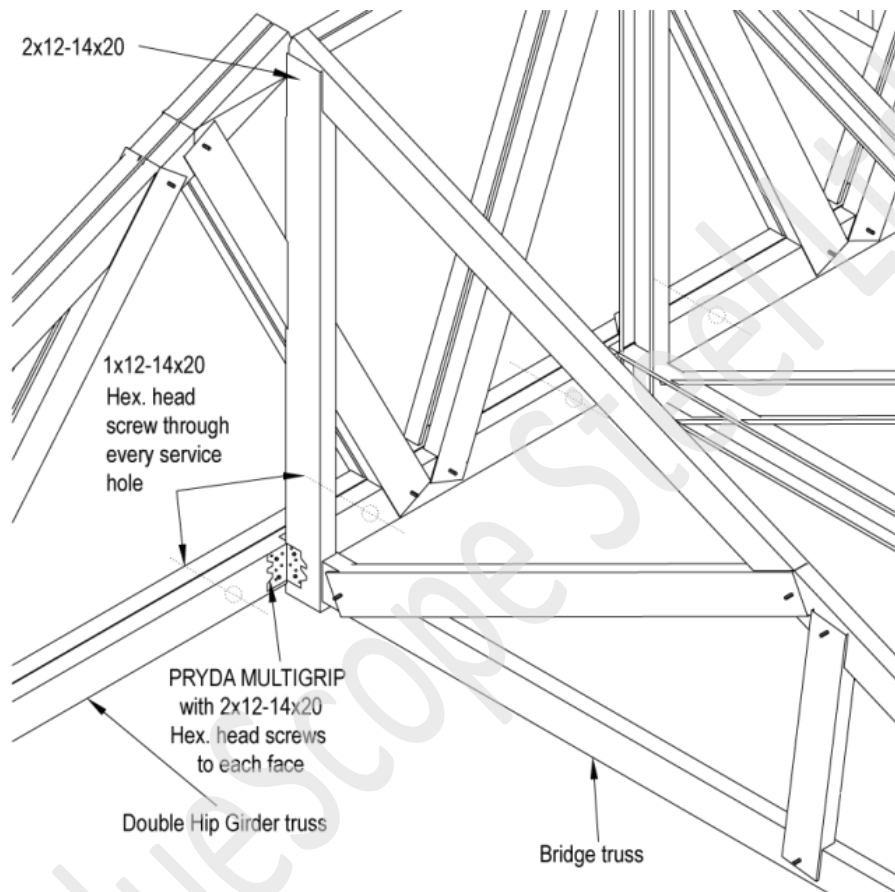

Figure 7.25a Bridge truss to hip girder truss connection

STEP 7: Bridge trusses are designed to span between the hip girder and end wall. Position bridge trusses at the locations marked on hip girder truss bottom chord and wall top plate. Install bridge trusses (half trusses) and fix to the external wall top plate using the tie down specified. Refer to section 7.8 for tie down options. Fix the bridge truss to the top chord of the girder truss with 2/12-14x20 screws through the web of top chord into the end vertical web of the bridge truss.

Fix the bridge truss to hip girder bottom chord as shown in fig. 7.25a. Using a multigrip fixed with 2x12-14x20 hex head screws. The tab on the bottom chord may need to be cut or bent for fixing. Ensure bridge truss spacing is not exceeded.

STEP 8: A single girder truss can be installed using either a 25 x 5mm strap tie down or a 50 x 50 x 3mm angle tie down as is shown in fig 7.25b(ii) or 7.25b(iii). Install the second ply girder truss (if applicable) with the toes of both trusses facing each other and fix it to the brackets as shown in fig 7.25b or 7.25b(i). Install 1x12-14x20 Hex Head screws through EVERY service hole provided on the bottom chord to connect the two trusses together as shown in fig 7.25a & 7.25b(iv).

STEP 9: Refer to step 8 of section 7.4.1 for hip rafter installation. In case of Veed Rafters, the difference is that the shorter rafter is located on the inside of hip while the longer rafter (supported by the truncated truss) is on the outside of the hip.

STEP 10: Refer to step 9 of section 7.4.1 for common / jack rafter installation.

STEP 11: Refer to step 10 of section 7.4.1 for creeper rafter installation.

NOTE: When all trusses are erected, install wind bracing as specified in Section 7.9 Roof Bracing.

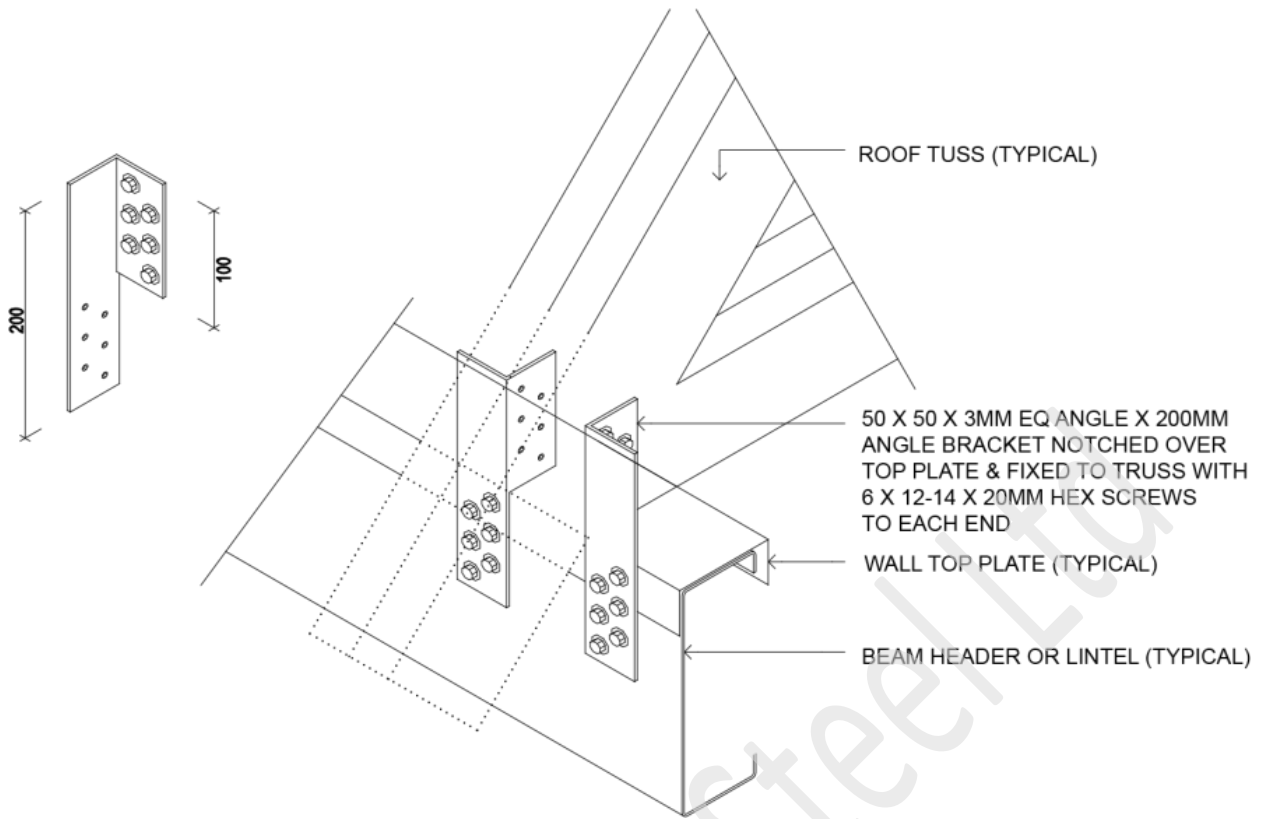

Figure 7.25b Girder truss to wall top plate connection using angle brackets

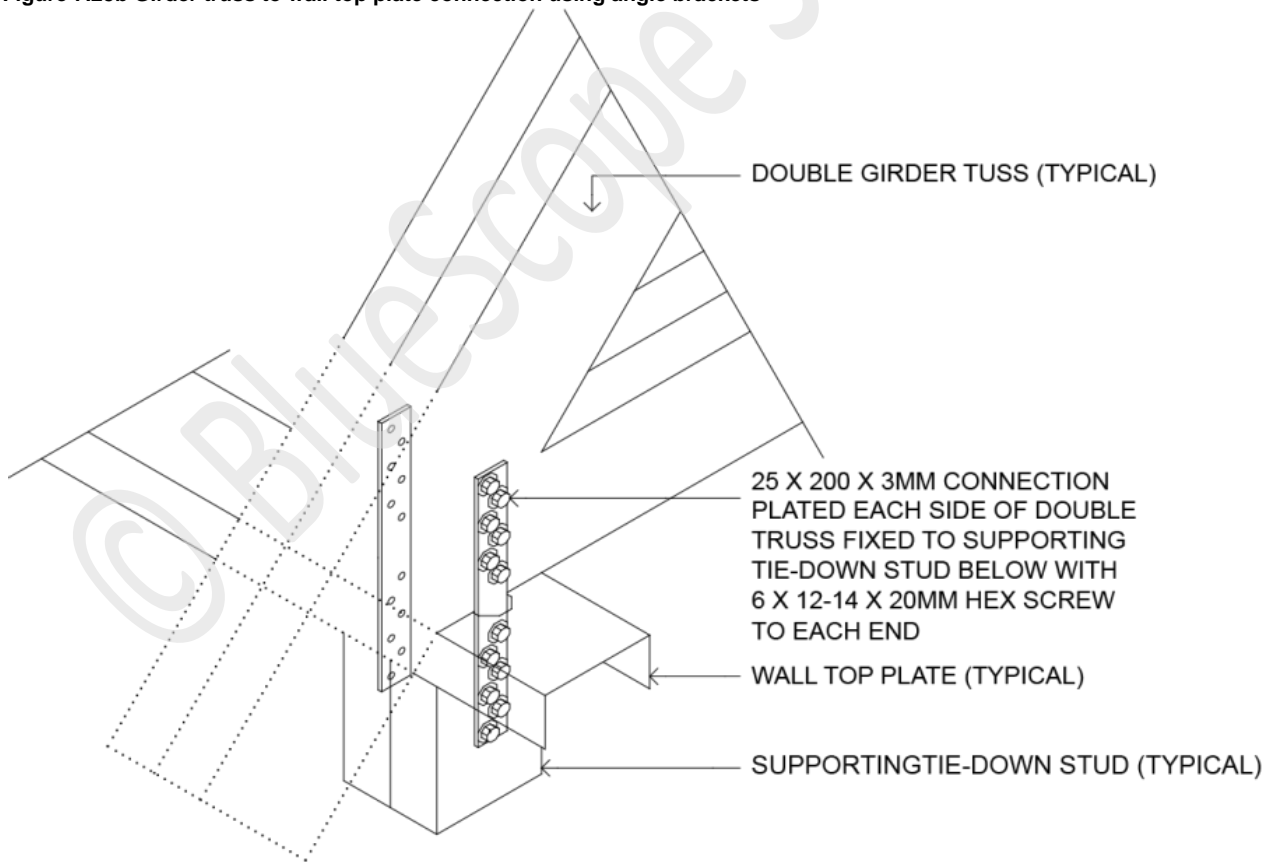

Figure 7.25b(i) Girder truss to wall top plate connection using strap tie downs

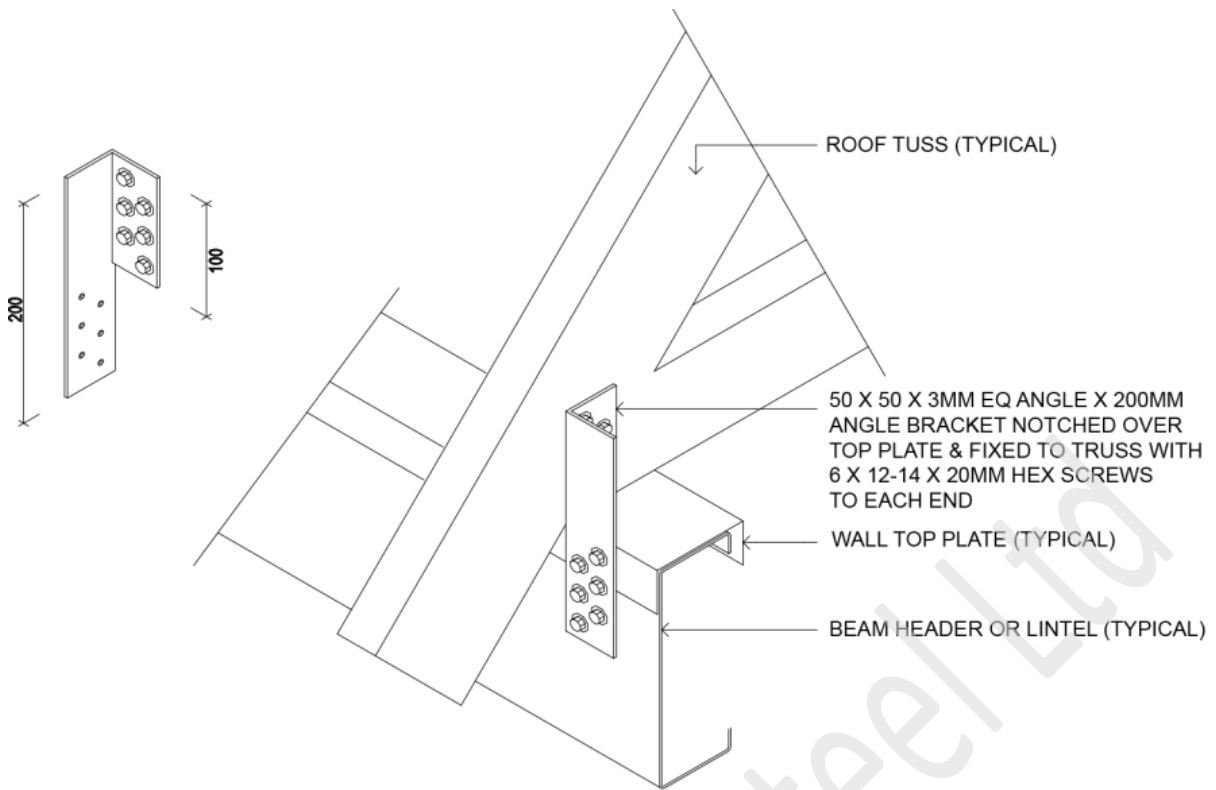

Figure 7.25b(ii) Single girder truss to wall top plate connection using angle tie downs

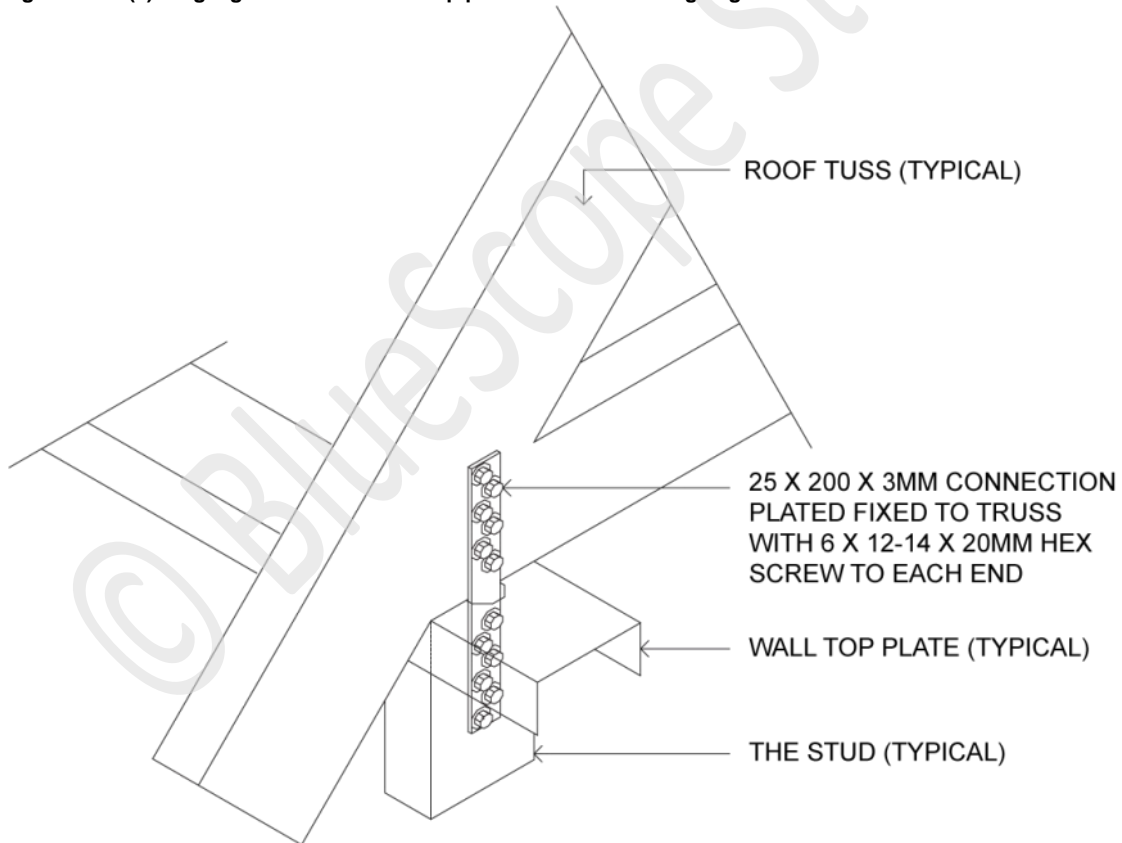

Figure 7.25b(iii) Alternative Truss Hold down for girder trusses

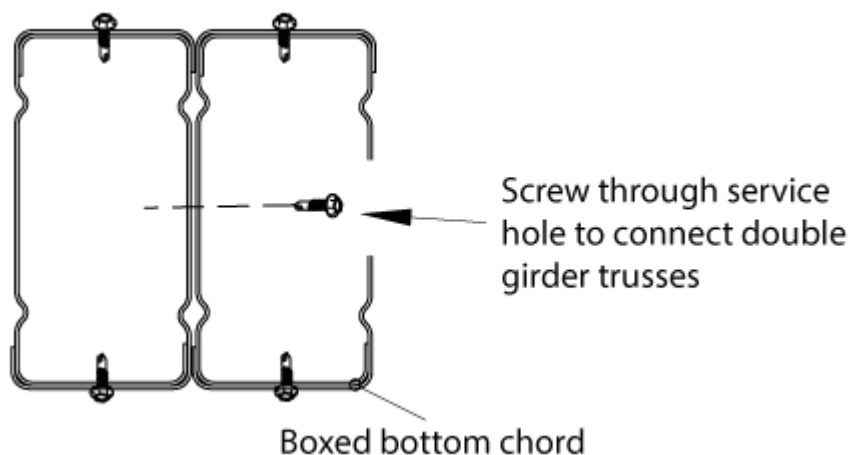

Figure 7.25b(iv) Connection between double girder trusses

7.5 Dutch gable construction



Figure 7.26 Dutch gable

Dutch gable construction

A Dutch gable is similar in construction to a Type 1 hip end. A standard A truss is provided at the nominated set-back position and is provided with a horizontal channel rail to support the rafters. Installation of truncated trusses and rafters is in accordance with the Type 1 hip end construction. The setback position is shown on the truss layout drawing. (Section 7.2).

STEP 1: Study the entire set of architectural and fabrication drawings.

STEP 2: Follow steps 2 to 6 of Section 7.4.1 Hip end construction.

STEP 3: Stand the Dutch gable truss orientated with the webs of the truss facing toward the hip end wall. The rafter support rail is orientated with the toes facing away from the hip end wall. (i.e. the same as the truncated truss chords). This provides a secure fixing of the rafter to the support rail.

STEP 4: Fix the truss to the heel brackets as per Hip end construction.

STEP 5: Temporarily brace the truss plumb and straight.

STEP 6: Install the Hip rafters as per **STEP 8** of section 7.4.1 Hip end construction fixing the rafter to the wall, truncated trusses and Dutch gable truss using the details shown.

STEP 7: Install Jack rafters where shown on the truss layout in accordance with **STEP 9** of Section 7.4.1 Hip. end construction.

STEP 8: Creeper rafters are supported by the hip rafter and the external wall. They are generally short rafters near the corner of the

building. Ensure sufficient back span is provided to give the installed rafter sufficient strength. Mark the overhang length on the creeper rafters as per the jack rafters. Install the creeper rafters in the locations shown on the layout drawing fixing to the creeper rafter and the wall top plates as shown in Fig. 7.9.

Fix creeper rafter to hip rafter as shown in Fig. 7.10, 7.11 and 7.12.

STEP 9: If not factory installed, fix battens to the Dutch Gable truss Chords to suit the fixing requirements of the Dutch gable end cladding. These battens should be spaced to suit claddings and designed to suit the length and loading criteria.

NOTE: When all trusses are erected, install wind bracing as specified in Section 7.9 Roof Bracing.

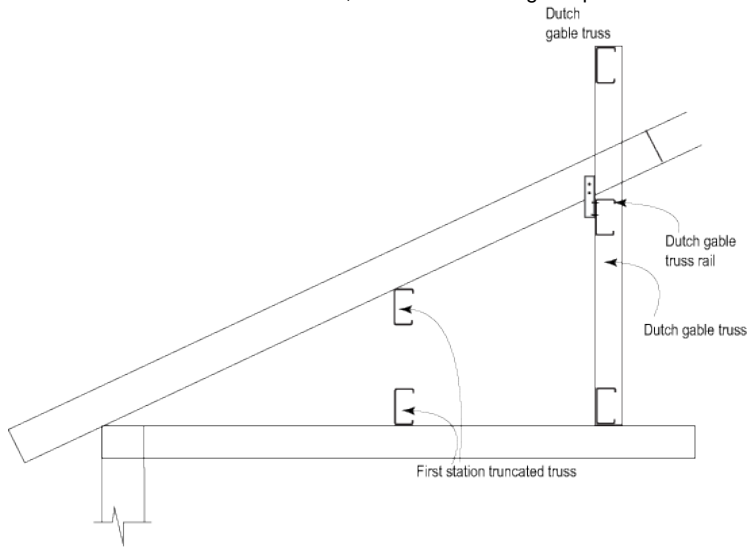

Figure 7.27a Dutch gable truss section view

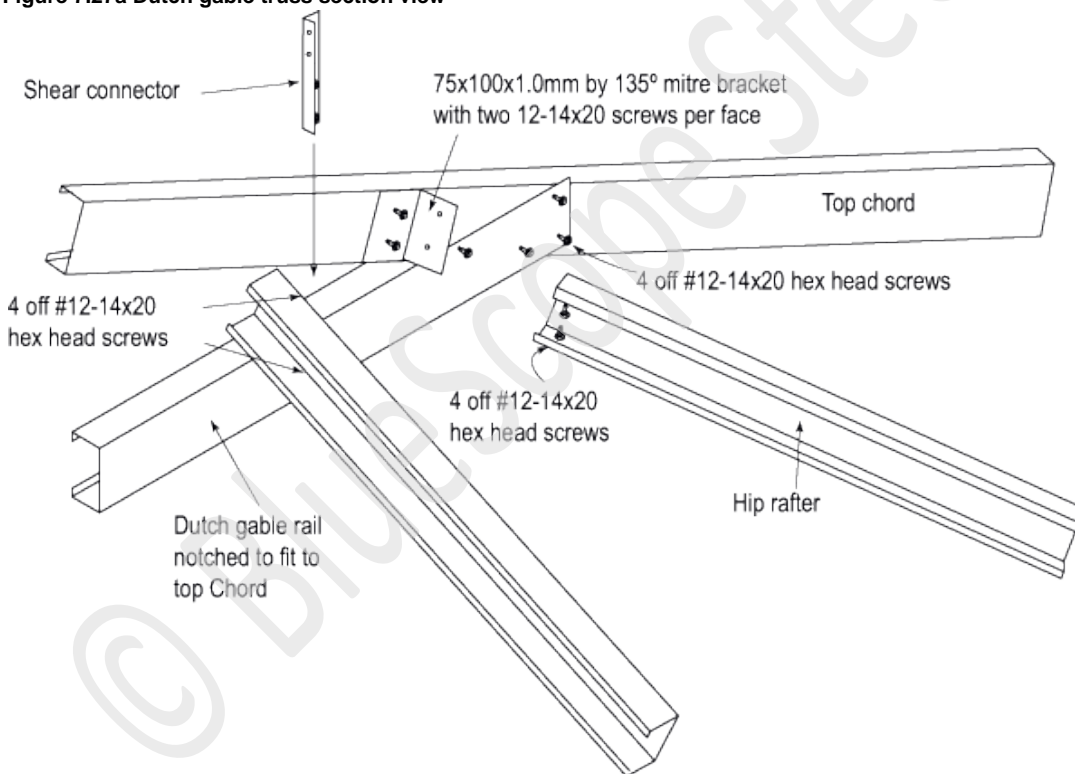

Figure 7.27b Dutch gable rail to top chord connection

7.6 Valley end construction

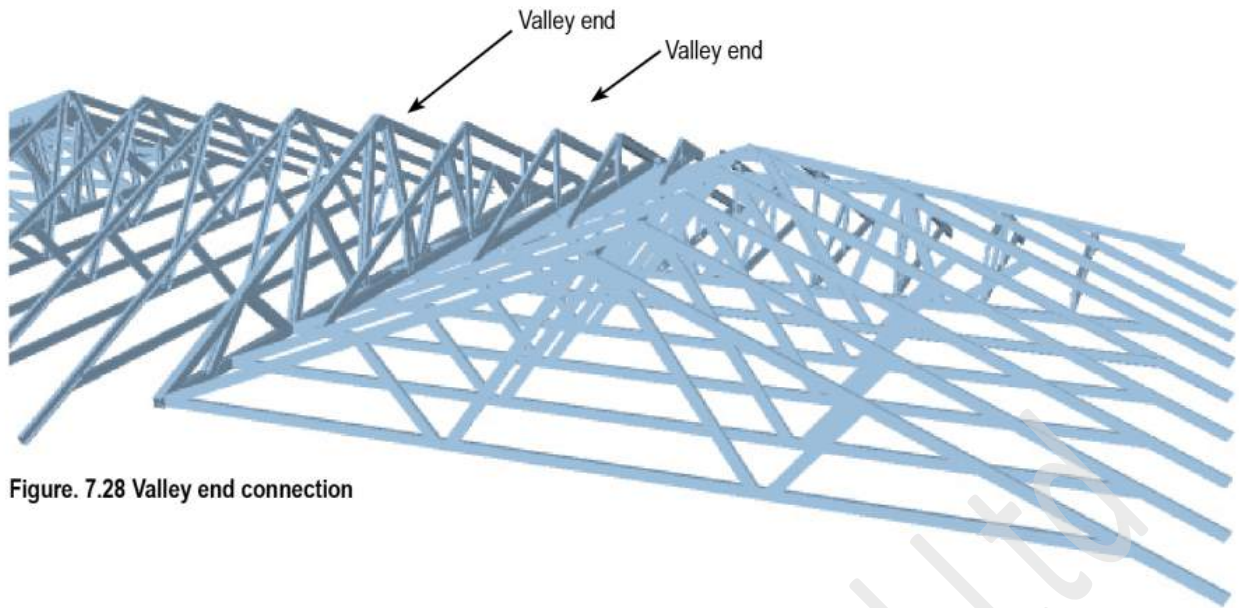

Figure. 7.28 Valley end connection

Fig. 7.28 shows a typical arrangement for bridge trusses supported by a girder truss. Saddle trusses are placed over the bridge trusses to infill the void and form the ridge line. This combination of bridge girder and saddle truss set is called a valley end.

Table 7.8.5 Limit State Design Loads for Pryda® TBJ45 Bracket (Bridge Truss to Girder Truss)

Top Chord	Bottom Chord	Fasteners Bracket to Girder Truss	Fasteners Bracket to Bridge Truss
0.75mm Boxed	0.75mm Boxed	8x#12-14x20	8x#12-14x20
1.0mm Boxed	1.0mm Boxed	8x#12-14x20	8x#12-14x20

7.6.1 Girder-bridge truss connection

STEP 1: Study the entire set of architectural and fabrication drawings.

STEP 2: Set out and mark truss position as per Section 7.2. Mark Bridge Truss positions on the Girder Truss bottom chord. Ensure that the bridge truss location is marked on the correct truss as specified in the girder truss fabrication sheet.

STEP 3: Install fixing brackets to the wall top plates to fix girders, bridge trusses and rafters in marked positions. Attach Pryda TBJ45 brackets to Girder bottom chord web in the marked positions. Note that the bottom chords of the Girder trusses are always boxed and that the brackets are fixed to the web of the bottom chord.

STEP 4: Install the first ply of the girder truss which has the Pryda TBJ45 bridge brackets installed and fix it to the hold down bracket at the heels.

STEP 5: Temporarily brace the girder truss and ensure that it is plumb and straight. This can be done using batten or roof bracing material fixed to the end wall and to the top chord of the truss.

STEP 6: Install the bridge trusses to the external wall and girder truss as shown in Fig. 7.28f.

STEP 7: Install the second ply girder truss (if applicable) with the toes of both trusses facing each other and fix it to the brackets as shown in Fig 7.28d. Install 1x12-14x20 Hex Head screws through EVERY service hole provided on the bottom chord to connect the two trusses together as shown in Fig. 7.28f Install 200 long plate sections with 4x12-14x20 hex- head screws to top chord near apex and midspan of top chord.

STEP: 8 The bridge trusses require to be trimmed at intersection of top and bottom chords. Refer to figure 7.28g.

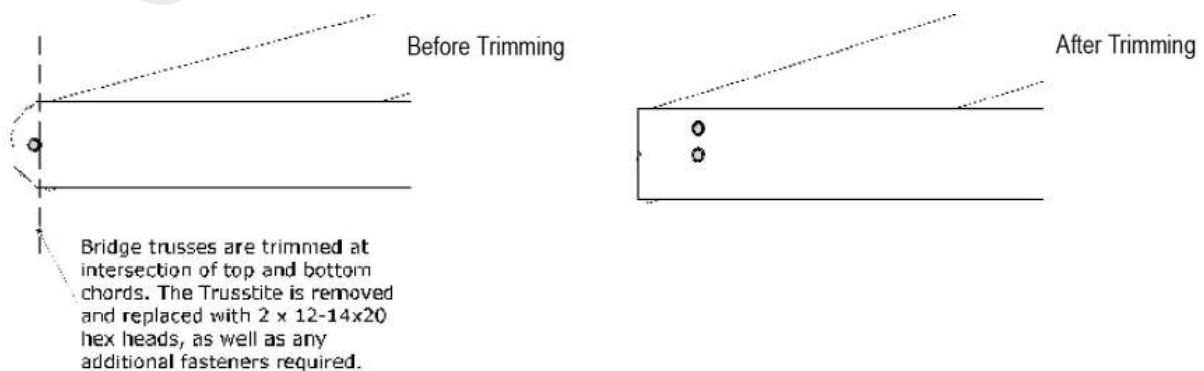

Figure 7.28g

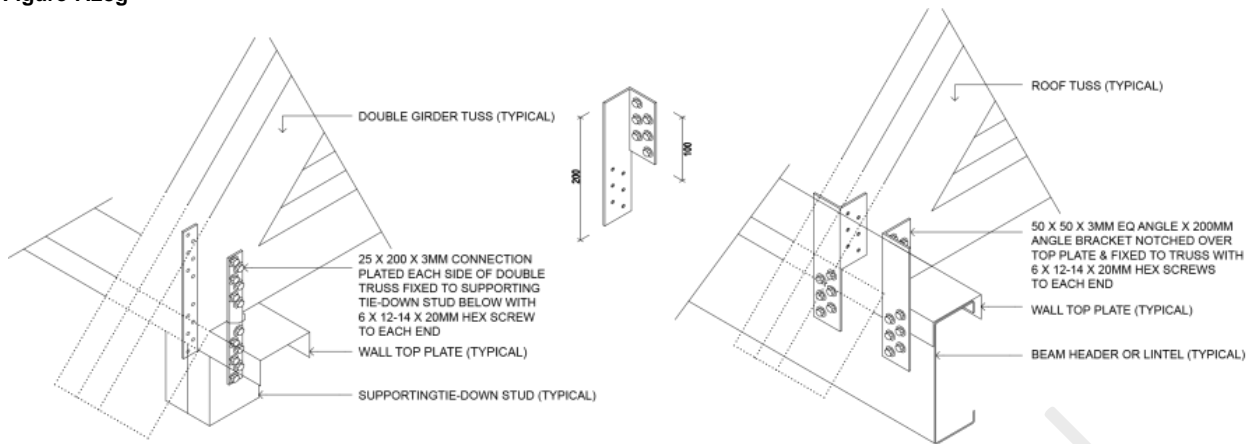

Figure 7.28d Double Girder Truss Hold down with angle and strap tie down option

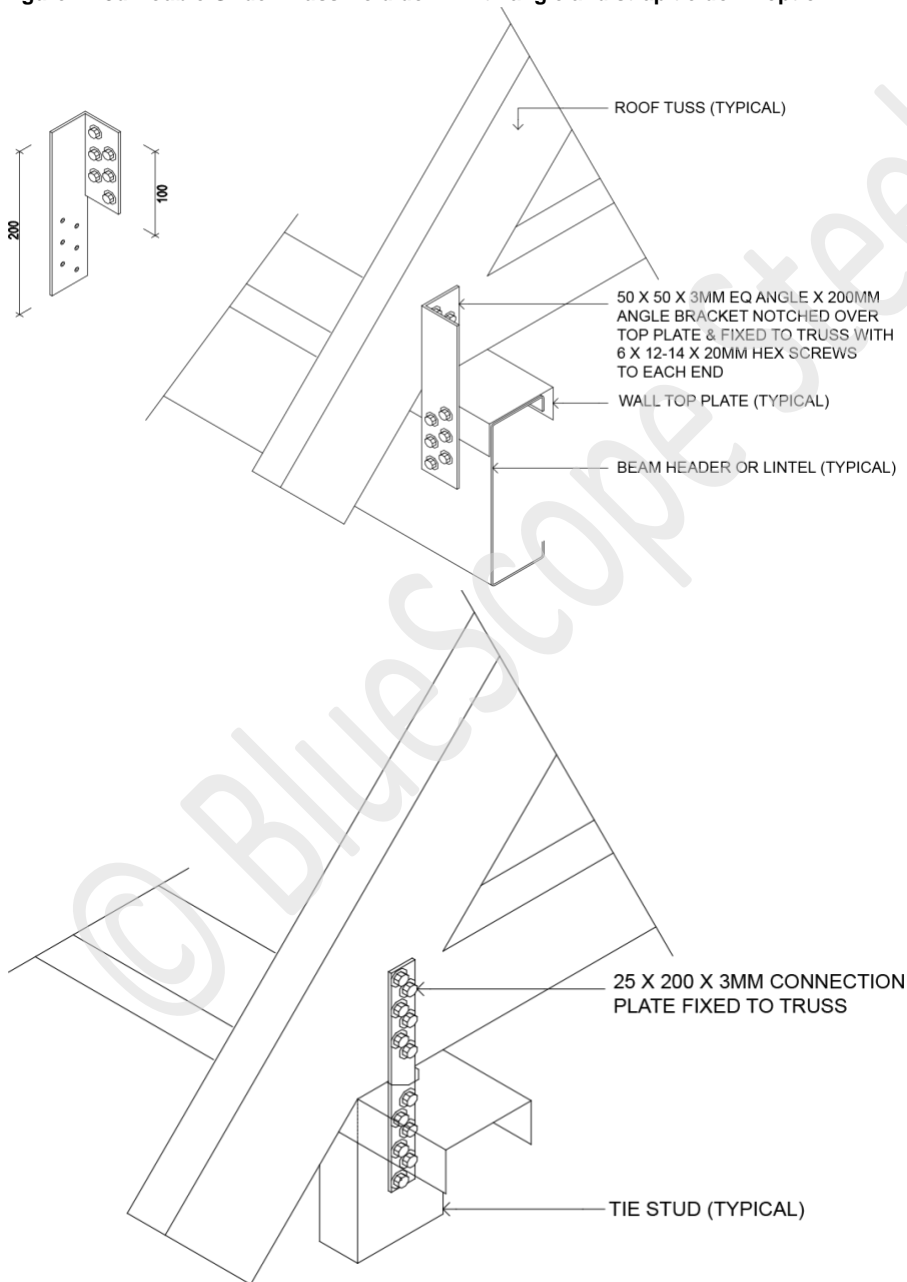

Figure 7.28e Single girder truss hold down

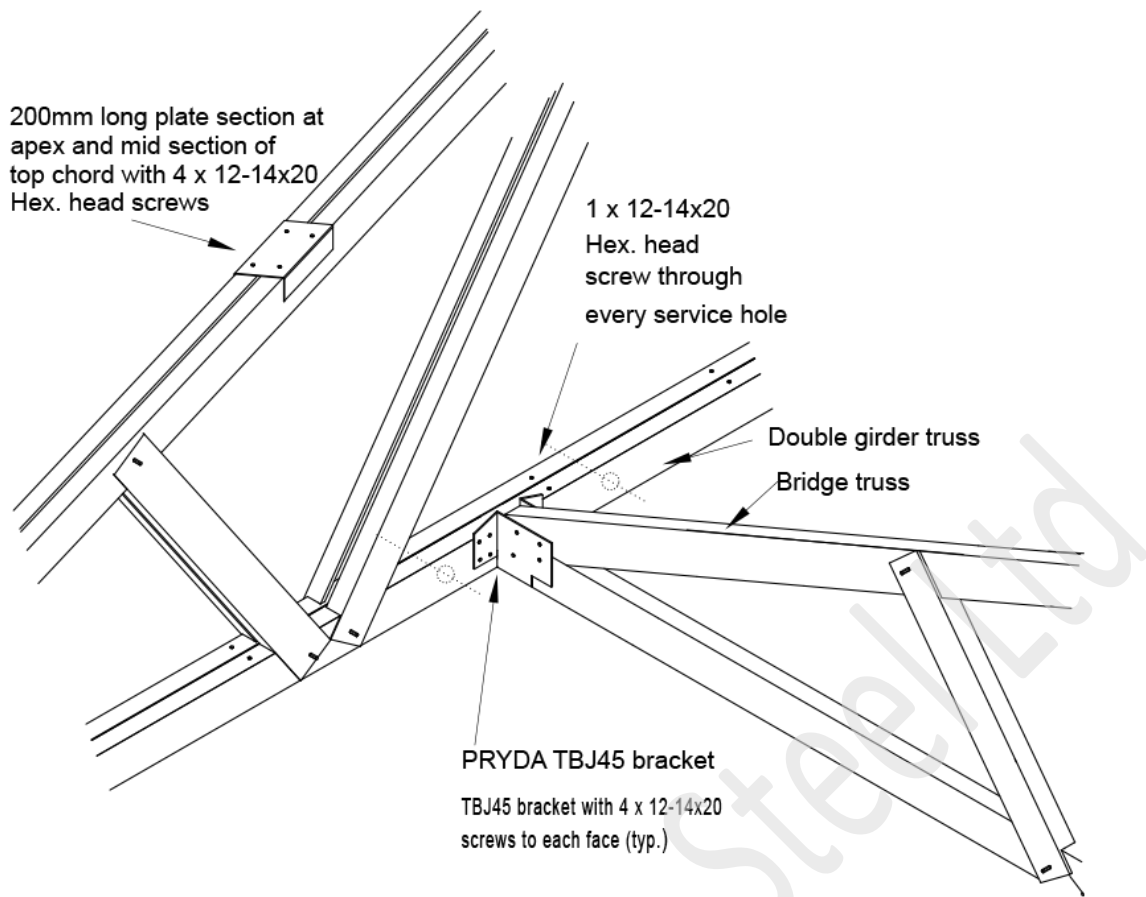

Figure 7.28f Double Girder Truss Connection

7.6.2 Saddle truss construction

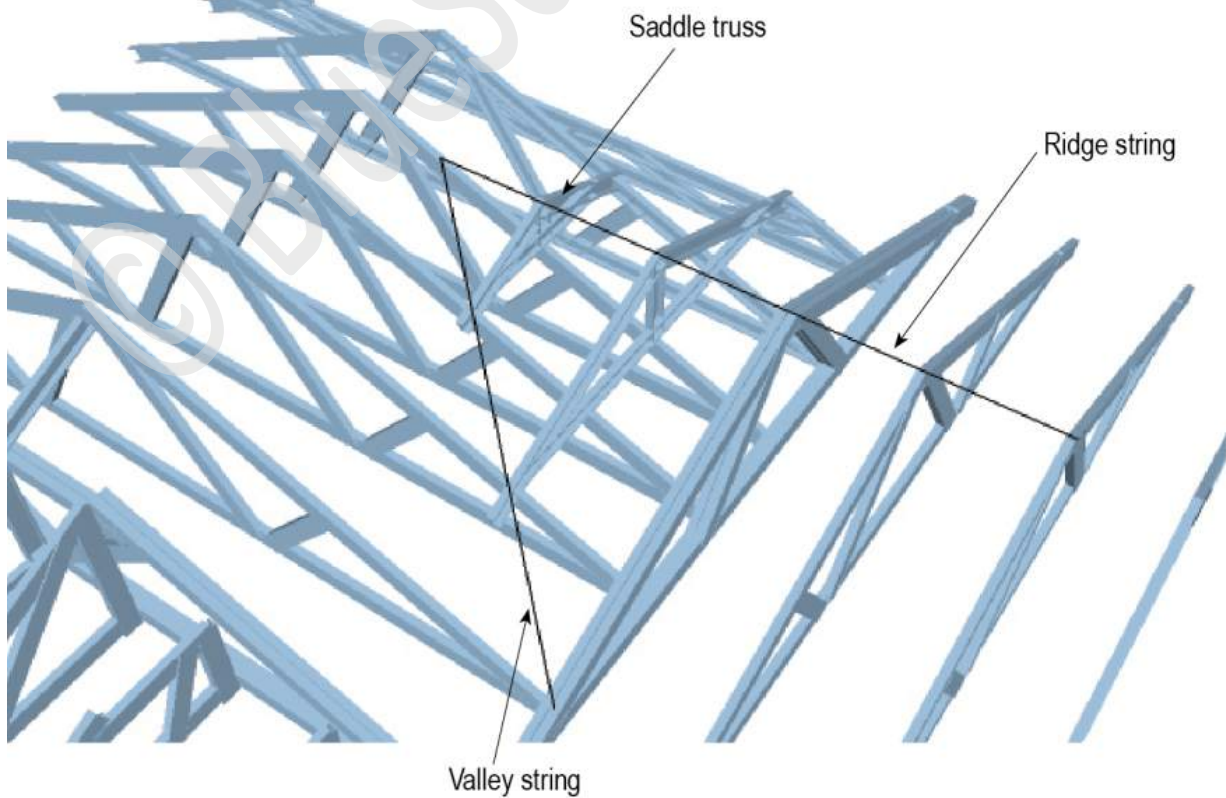

Figure 7.29a Saddle truss detail

STEP 1: Study the entire set of architectural and fabrication drawings.

STEP 2: Fix a string line along the ridge line of your roof and down the valley lines to aid in the positioning of saddle trusses as shown in Fig. 7.29a.

STEP 3: Position the largest saddle truss keeping it parallel to the edge of the main roof. With the open face of the bottom chord facing down the slope and the webs facing up the slope, adjust the truss positions so that the long points of the foot cut line up with the valley string lines.

STEP 4: When the saddle truss is standing plumb, the apex line should line up with the apex string line.

STEP 5: Fix the bottom chord of the saddle trusses to the top chord of the underlying truss with an angle bracket as shown in Fig. 7.29c.

STEP 6: Repeat steps 3, 4 and 5 for subsequent saddle trusses until the saddle block is complete.

STEP 7: Temporarily brace the apex of the saddle trusses.

NOTE 1: The smallest saddle truss will require a trimmer to be installed below it for extra support as shown in Fig. 7.29b.

NOTE 2: When all trusses are erected, install wind bracing as specified in Section 7.9 Roof Bracing.

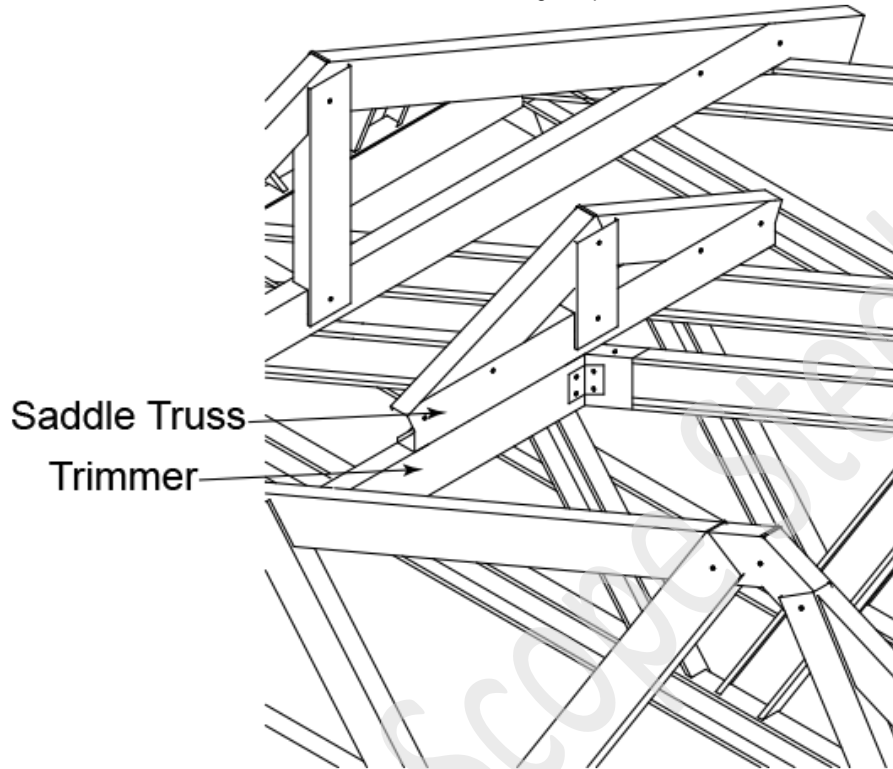

Figure 7.29b Saddle truss trimmer detail

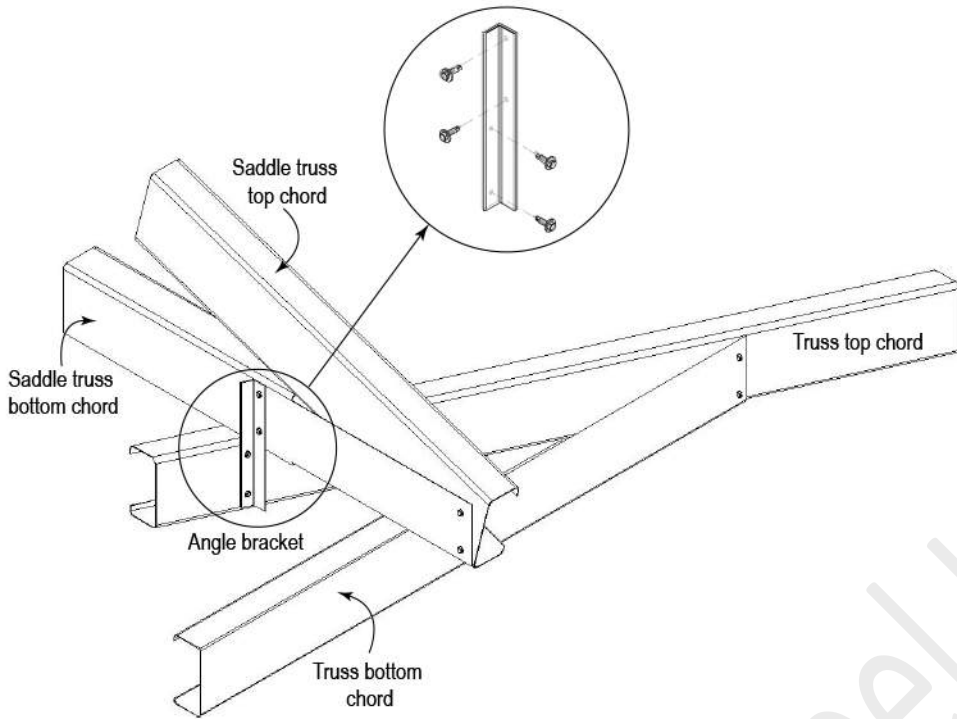

Figure 7.29c Saddle truss connection

7.6.3 Radial Roof

A diagrammatic representation explaining the various elements of a radial truss is shown in Figure 7.30. Radial trusses consist of the following elements:-

Girder truss. This is the same as standard girder trusses.

Barrel. This is connected to two vertical members on the girder truss and rotates around. A picture of the barrel including dimensions is shown in Figure 7.30a

Primary trusses. These are half trusses attached to the barrel radiating out from a central point on the girder truss and sit at the hip corners of the roof. NOTE: the max length for half trusses to be used is 6m.

Secondary trusses. These are half trusses that are in between the primary trusses. They are placed when the Primary truss spacing exceeds the standard truss spacing in between the primary trusses at the eave line and may be attached to the face of the Barrel. These trusses typically remain perpendicular to the pitching line.

Intermediate trusses. These are the remaining trusses that are may be required between the Primary and Secondary trusses if the spacing is greater than the truss spacing at the eave.

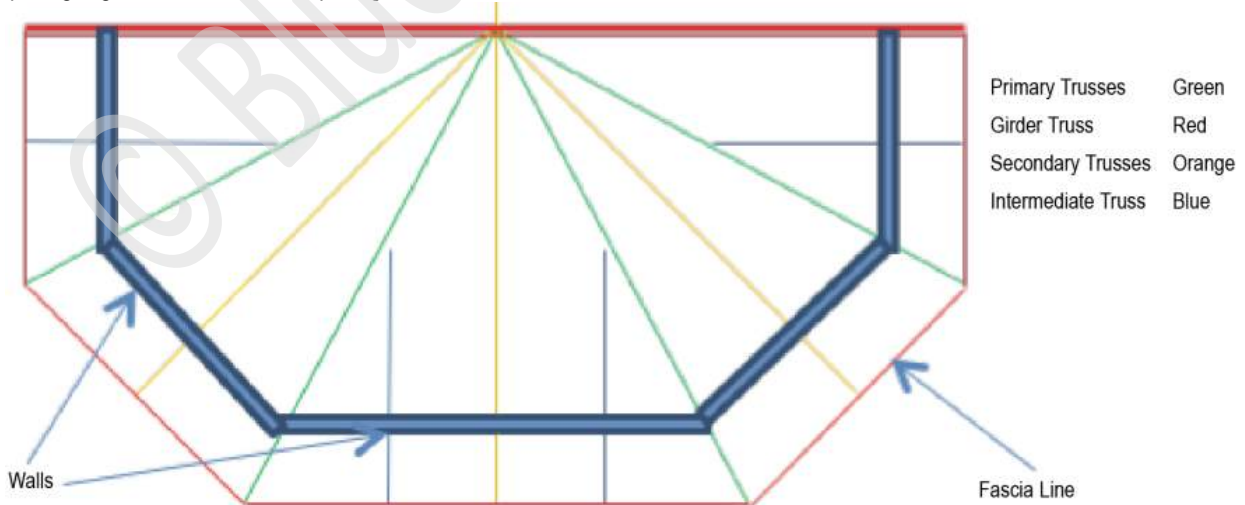

Figure 7.30 Radial truss key components

STEP 1: Study the entire set of architectural and fabrication drawings. The Truss components in this area include the Girder, Primary, secondary and intermediate flush trusses.

STEP 2: Set out and mark truss positions as per Section 7.2.

STEP 3: If the Barrel(s) (pressed metal bracket(s)) have been sent as loose items, please fix to Girder truss as per the drawing

below. The flat face of the girder truss provides a smooth face to attach 2 vertical rails which, in turn, support the barrel(s). Depending on the height of the truss will depend if there are one or two barrels. The lower barrel will be connected with a Trusstite through a pre-punched self-locating hole in the barrel, which is aligned with a self-locating hole in the vertical section and the truss chord. A total of 5 screws with either 12-14x20 hex head fasteners or 1 x Trusstite and 4x12-1x20 fasteners attached on each side of the barrel into the vertical section. The top barrel will usually be site fixed so the top chords of the half trusses do not clash, and will be fixed with 5x12-1 4x20 hex head fasteners.

STEP 4: Install fixing brackets to support structure in marked positions.

STEP 5: Lift Girder into set-out position. And fix two #12-14x20mm hex head self-drilling screws through the fixing bracket at each heel connection into the truss Chord. If erection screws positions clash with truss manufacture fasteners remove these screws and replace with the erection screws through the bracket and into the chords in the same location.

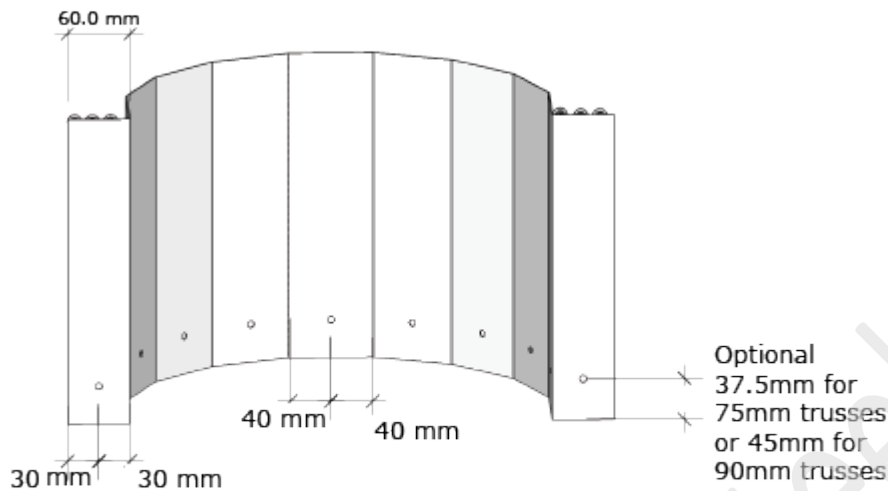

All holes are in the center of each segment of the barrel and are located 37.5mm from the end for a C75 truss or 45mm for a C90 truss

Figure 7.30a Barrel Brackets Details

STEP 6: Temporarily brace the truss and ensure it is plumb and straight. This can be done using batten or roof bracing material fixed to the end wall and to the top chord of the truss.

STEP 7: The Hip trusses (noted as the primary trusses) are next. Lift and place as per set out. Most commonly these hips run over the corners of the building. They are to be attached at the wall frame as per Figure 7.8 and 7.9. Depending upon the wind, dead load and span fixings needed. At the barrel end of the hip (primary) trusses, the bottom chord has a tab extending 40mm past the vertical chord. This is manually bent 90 degrees so the 6mm locating hole can be used to align the bottom of the truss to pre-punched holes in the barrel to get the correct height. The top chord on the other hand extends and runs over the barrel to give a more complete hip line and for battens to connect to. Half trusses are connected onto the face of the barrels with an additional 4x12-14x20 hex head fasteners as per Figure 7.30c(i) and 7.30c(ii). Or If not using the Trusstite use 5x12-14x20 hex head fasteners. The load from the half truss is transferred to the barrel with these fasteners.

NOTE: These fastenings can be made from front or back faces of the barrel.

STEP 8: Lift the secondary trusses following the same set out as Step 7 and the same process where it meets the barrel but will actually sit perpendicular to the wall frame and can be attached to the wall frame with hold down methods suitable.

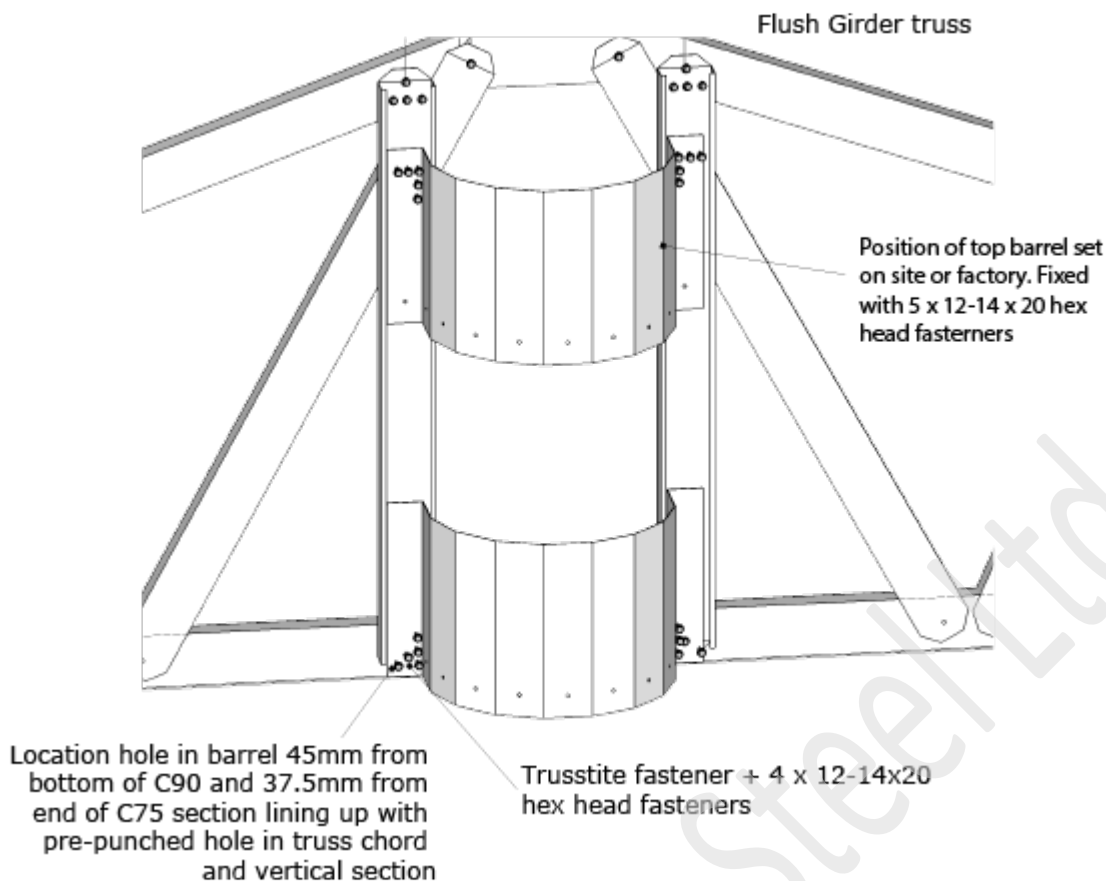

Figure 7.30b Position of barrels on vertical section

STEP 9: Lift the remaining intermediate trusses into their required position and use the same tie down fixing on the wall frame as per the secondary trusses. Where these intermediate trusses join to the primary trusses ensure that some partial boxing plate is added (to the open side of the primary truss) and fixed with 4x12-14x20 hex head fasteners through the flanges towards the ends of this piece. These intermediate trusses have an extension to the top chord that will manually need to be bent to fix to the primary truss as this area. This bent tab is attached with 2x2-14x20 fasteners through this top chord extension into the top chord of the oncoming truss. The bottom chord also is extended of this intermediate truss and follows the same partially boxing method as just described. Refer to figures 7.30d(i) and 7.30d(ii).

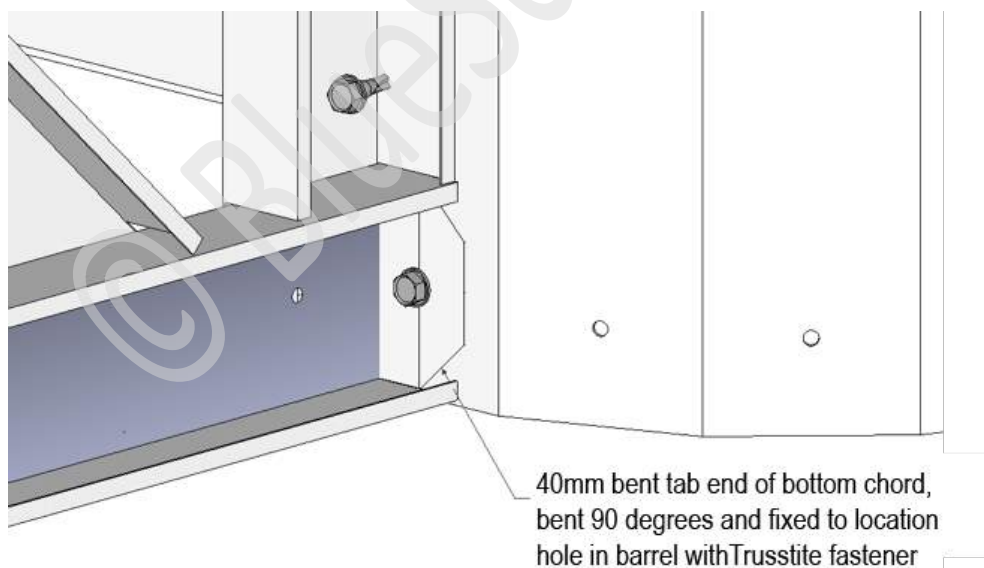
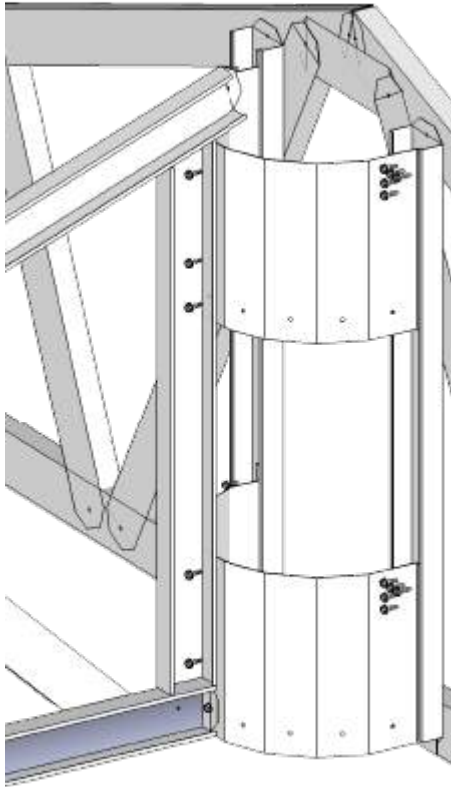

Figure 7.30c(i) Bend tab at end of half truss to locate the bottom chord onto a pre-punched hole in the barrel



Fasteners can also be installed from back of barrel.

Figure 7.30c(ii) Connecting half trusses to barrels with 1 x Trusstite and 5 x 12-14x20 hex head fasteners

Half trusses are connected onto the face of the barrel with an additional 5 x 12-14x20 hex head fasteners as per Figure 7.30(ii). The fasteners can be screwed through the back of radial to truss if required. The load from the half truss is transferred to the barrel with these fasteners.

The end of the intermediate truss top chord extends past the primary truss by 40mm. It is notched on both flanges and is manually bent, and attached with 2 x 12-14x20 hex head fasteners.

The end of the intermediate truss bottom chord extends past the primary truss by 40mm. It is notched on both flanges and is manually bent, and attached with 2 x 12-14x20 hex head fasteners.

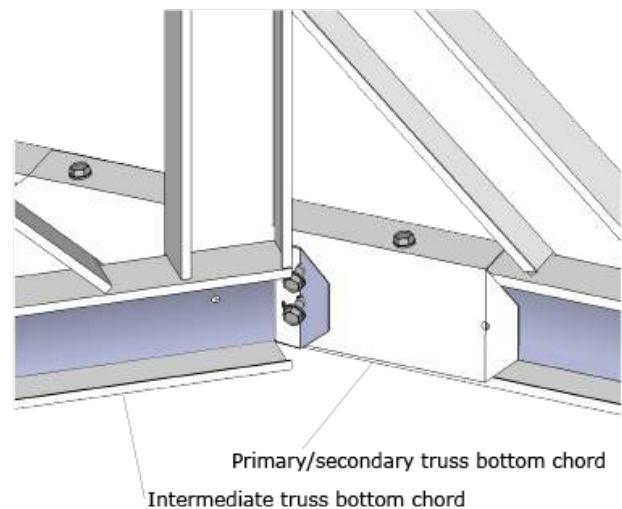
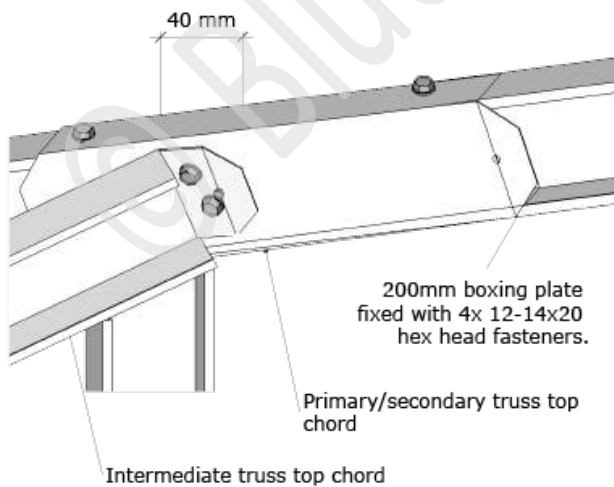

Figure 7.30d(i) Connection between primary and intermediate truss (Top Chord) and Figure 7.30d(ii) Connection between primary and intermediate truss (Bottom Chord)

7.7 Common roof block construction

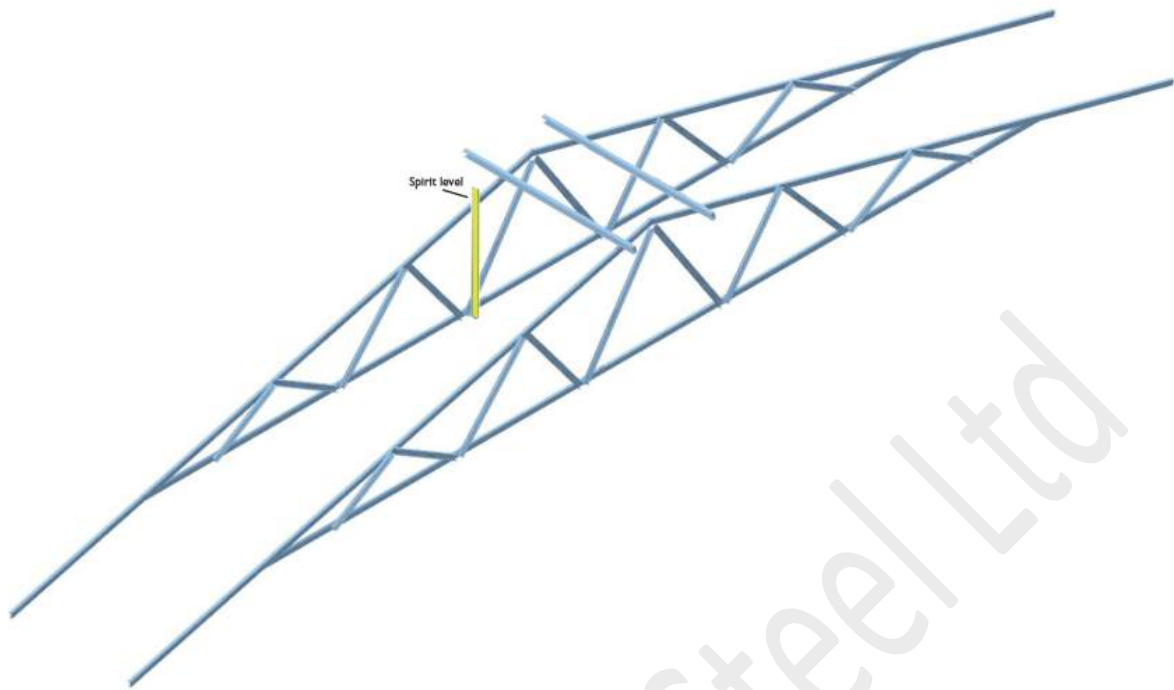

Figure 7.31 Use spirit level to plumb truss

STEP 1: Study the entire set of architectural and fabrication drawings.

STEP 2: Mark out truss positions on the top plate as per the Roof Framing Layout. Refer to Section 7.2 Roof Truss Set-Out.

STEP 3: Install gables, hips and Dutch gables in accordance with Sections 7.3, 7.4 and 7.5 of this manual. Install remaining trusses in their set-out positions and secure using two #12-14x20mm hex head tek screws through the fixing bracket at each heel connection into the side of the top plates. Temporarily brace as close as possible to the apex of each truss to plumb and straighten.

NOTE 1: To keep trusses in-line, simply maintain a straight line at the apex of all trusses this can be done using a string line. Alternatively, run a string line along a common point on the trusses.

NOTE 2: When all trusses are erected, install wind bracing as specified in Section 7.9 Roof Bracing.

7.8 Truss and Rafter Tie Down Connections

The designer should specify the tie down system to be used for each job with reference to ENDUROCADD® truss and rafter reactions and standard connection design capacities. The truss and rafter reactions to be resisted are calculated by the ENDUROCADD® software, however a ready reckoner on the reactions to be resisted under a range of roof truss spacings, spans and wind loads are shown in tables 7.8.2a, 7.8.2b and 7.8.2c. Note that these tables may be more conservative than the values calculated by the ENDUROCADD® software.

Table 7.8.2a. Truss Downward Reactions for a Tile Roof in a non-cyclonic region

1000mm Overhang	TRUSS DOWNWARD REACTIONS AT TOP PLATE (KN) UNDER TILE ROOF								
	TRUSS CENTRES (mm)								
	600			900			1200		
Truss Span	N1	N2	N3	N1	N2	N3	N1	N2	N3
4	3.08	3.39	4.02	4.42	4.89	5.84	5.76	6.39	7.66
5	3.50	3.86	4.59	5.06	5.60	6.69	6.62	7.33	8.79
6	3.93	4.33	5.15	5.70	6.31	7.53	7.47	8.28	9.91
7	4.36	4.81	5.71	6.35	7.02	8.38	8.33	9.23	11.04
8	4.79	5.28	6.28	6.99	7.73	9.22	9.19	10.17	12.17
9	5.22	5.75	6.84	7.63	8.44	10.07	10.04	11.12	13.30
10	5.64	6.23	7.41	8.27	9.15	10.91	10.90	12.06	14.42
11	6.07	6.70	7.97	8.92	9.86	11.76	11.76	13.01	15.55

12	6.5	7.17	8.53	9.56	10.56	12.61	12.61	13.96	16.68
13	6.93	7.65	9.10	10.20	11.27	13.45	13.47	14.90	17.81
14	7.36	8.12	9.66	10.84	11.98	14.30	14.33	15.85	18.93
15	7.79	8.59	10.22	11.49	12.69	15.14	15.18	16.80	20.06

Table 7.8.2b Truss Uplift Reactions at Top Plate under a Sheet Roof – Non-Cyclonic

1000mm Overhang	TRUSSUPLIFT REACTIONS AT TOPPLATE (KN) UNDER SHEET ROOF									
	Truss Span	TRUSS CENTRES (mm)								
		600			900			1200		
	N1	N2	N3	N1	N2	N3	N1	N2	N3	
4	1.16	1.77	3.00	1.74	2.65	4.50	2.32	3.54	6.00	
5	1.32	2.02	3.43	1.98	3.02	5.14	2.64	4.03	6.85	
6	1.48	2.26	3.85	2.22	3.40	5.78	2.96	4.53	7.70	
7	1.64	2.51	4.28	2.46	3.77	6.41	3.28	5.02	8.55	
8	1.80	2.76	4.70	2.70	4.14	7.05	3.60	5.51	9.40	
9	1.96	3.00	5.13	2.94	4.51	7.69	3.91	6.01	10.25	
10	2.12	3.25	5.55	3.17	4.88	8.33	4.23	6.50	11.10	
11	2.28	3.50	5.98	3.41	5.25	8.96	4.55	7.00	11.95	
12	2.43	3.74	6.40	3.65	5.62	9.60	4.87	7.49	12.80	
13	2.59	3.99	6.83	3.89	5.99	10.24	5.19	7.98	13.65	
14	2.75	4.24	7.25	4.13	6.36	10.88	5.50	8.48	14.50	
15	2.91	4.49	7.68	4.37	6.73	11.52	5.82	8.97	15.35	

Table 7.8.2c Truss Uplift Reactions at Top Plate under a Sheet Roof – Cyclonic

1000mm Overhang	Truss Uplift Reactions at Top Plate under a Sheet Roof – Non-Cyclonic						
	TRUSS SPAN (m)	TRUSS CENTRES (mm)					
		600			900		
	C2	C3	C4	C2	C3	C4	
4	6.01	9.04	12.36	9.02	13.56	18.54	
5	7.01	10.55	14.42	10.52	15.83	21.63	
6	8.01	12.06	16.48	12.02	18.09	24.72	
7	9.02	13.56	18.54	13.52	20.35	27.81	
8	10.02	15.07	20.60	15.03	22.61	30.90	
9	11.02	16.58	22.66	16.53	24.87	33.99	
10	12.02	18.09	24.72	18.03	27.13	37.08	

Note:

- 1) The wind pressure coefficients to determine Truss Uplift Reactions are based on AS 4055-2011 Table 3.1
- 2) Truss uplift reactions are based on most critical design conditions (slope, input parameters of Pressure Coefficients from AS 4055 etc.).
- 3) Accurate uplift reactions to suit the truss /building layout configuration and AS 1170.2 wind pressure coefficients can be obtained from ENDUROCADD® Software Engineering sheet output.

Based on the reactions selected from Tables 7.8.2a, 7.8.2b or 7.8.2c an appropriate tie down shall be selected. The selection of an appropriate tie down depends on a number of factors:-

1. The thickness of the truss chord;
2. The thickness of the top plate;
3. The thickness of the stiffening piece;

4. Whether the trusses are landing in between studs, are directly tied to a stud or above a 200 x 30 x 1.5mm lintel;
5. The type of tie down selected;
6. The tie down should be selected AFTER the truss, top plate, stud, and stiffener thicknesses have been determined, and whether the studs are aligned under trusses or will be attached to a 1.5mm thick lintel. The top plate should be checked for truss downward reactions. The tie downs can be selected in the ENDUROCADD® software and shown on tie down sheets, however Table 7.8.3 can also be used as a guide based on a selection of truss and wall frame configurations.

Table 7.8.3 – Connection Capacity of various configurations of truss chords, studs, top plates and tie downs

Top Plate Thick	Min. Truss Chords Thick	Top plate stiffener used	Min. Stud & Stiffener Thick	Connection Capacity (kN)										
				Tie Down type***										
				A	2A	B	2B	C	2C	D	E	F		
0.75	0.75	Yes	0.75	3.8	5.6	4.9	5.6	5.6	5.6	-	-	-	-	-
1.0	0.75	Yes	1.0	3.8	7.6	4.9	8.5	8.4	8.5	-	-	-	-	-
1.0	0.75	Yes	1.2	3.8	7.6	4.9	9.3	8.4	9.3	-	-	-	-	-
1.0	1.0	Yes	0.75	4.4	7.4	6.0	7.4	7.4	7.4	-	-	-	-	-
1.0	1.0	Yes	1.0	4.4	8.5	6.0	8.5	8.5	8.5	-	-	-	-	-
1.0	1.0	Yes	1.2	4.4	8.8	6.0	9.3	9.3	9.3	-	-	-	-	-
1.2	0.75	Yes	0.75	3.8	7.4	4.9	7.4	7.4	7.4	-	-	-	-	-
1.2	0.75	Yes	1.0	3.8	7.5	4.9	9.6	8.4	9.6	-	-	-	-	-
1.2	0.75	Yes	1.2	3.8	7.5	4.9	9.8	8.4	12.3	-	-	-	-	-
1.2	1.0	Yes	0.75	4.4	7.4	6.0	7.4	7.4	7.4	-	-	-	-	-
1.2	1.0	Yes	1.0	4.4	8.8	6.0	9.6	9.6	9.6	-	-	-	-	-
1.2	1.0	Yes	1.2	4.4	8.8	6.0	12.0	12.3	12.3	-	-	-	-	-
0.75*	1.0	No	0.75	-	-	-	-	-	-	27	-	-	-	-
0.75	1.0	No	1.0	-	-	-	-	-	-	-	23.7	-	-	-
NA**	0.75	NA	NA	-	-	-	-	-	-	-	-	-	18.6	-

Note: each option assumes that the plates are connected to studs with 1 x M6x1Px15mm smooth top fastener on each side of the plate.

- Option requires a 200 x 35 x 1.5mm lintel to be installed.
- For bolting to a masonry wall or structural steel connection with a minimum M12 bolt through a 50 x 3mm square washer.

A 2 in front of the connection type denotes a double connection into a boxed section.

A description of the Tie Down types is shown in Table 7.8.4

Table 7.8.4

C Plate Transition Bracket

Plate transition bracket hold down
4 x #12-14 x 20 hex head fasteners between bracket and truss, and 2 x M6x1Px18mm Smooth Top Tek screws from bracket into each side of top plate for a total of 8 fasteners. Transition part thickness must have the same minimum thickness as the top plate.

D 50x50x3.0 Equal Angle

50x50x3MM x200mm Equal Angle bracket hold down detail
The 50 x 50 x 3mm x200mm Equal Angle bracket hold down is to be fixed with 6x12-14x20 Hex head or 6xM6 x 1P x 18mm self drilling screws into both the truss and the wall frame for a total of 12 screws.

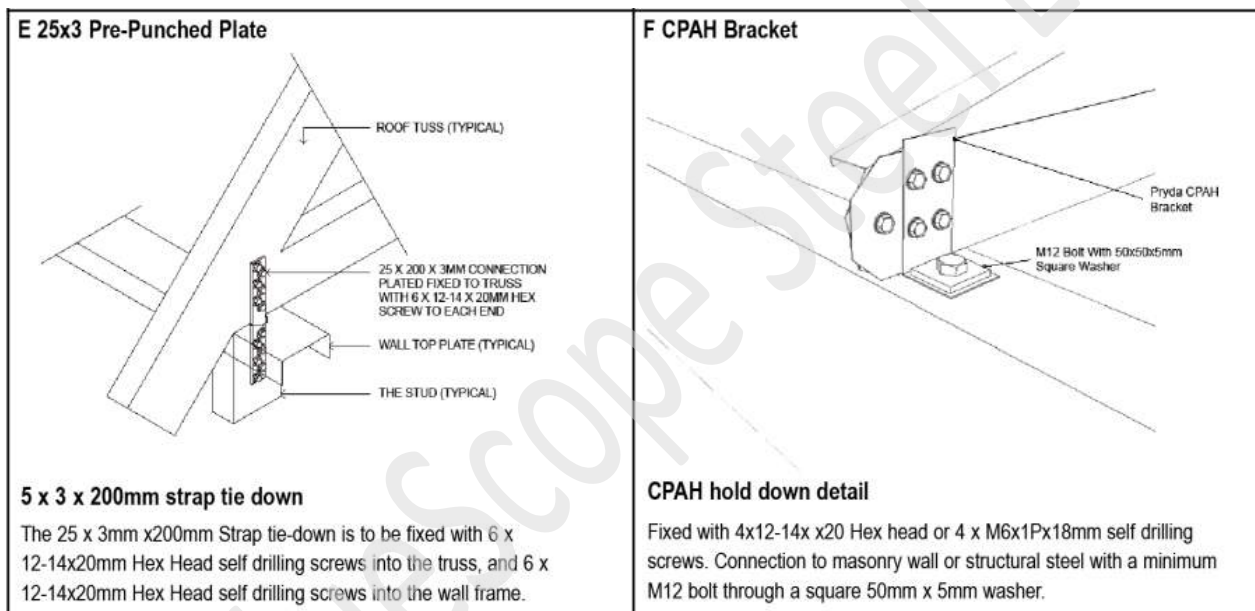
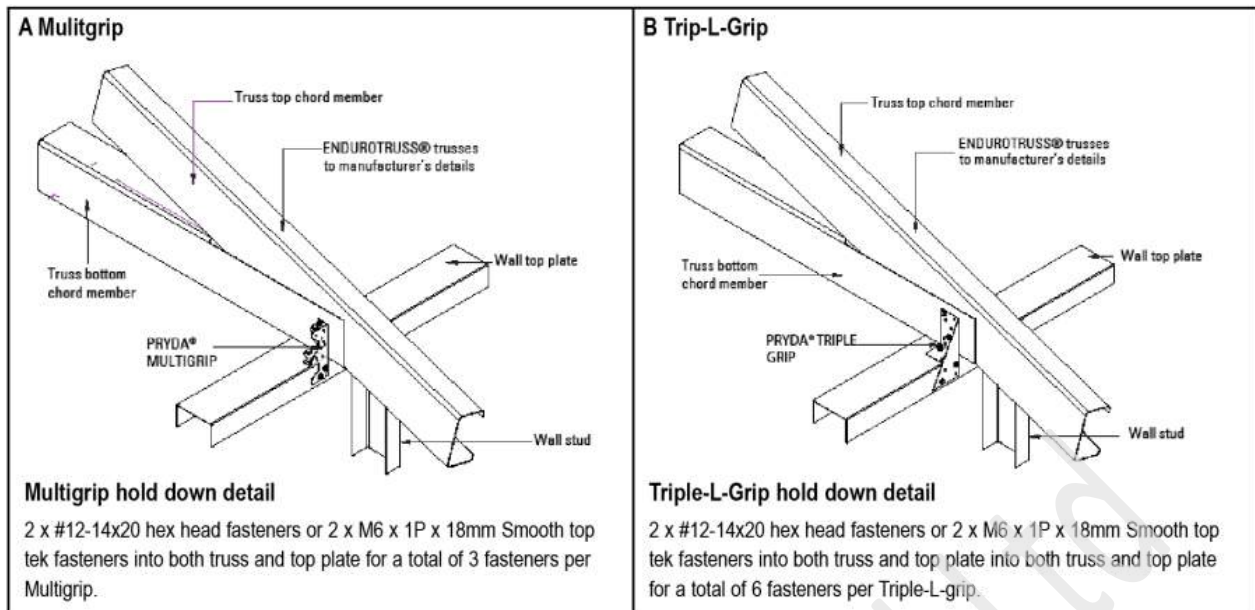

7.8.1 Boxed Tie Downs

To attach a tie down to the reverse side of a truss or rafter the section will need to be boxed with a 200mm long boxing piece. This boxing piece can be cut back from a piece of scrap steel and attached to the truss. For apex trusses the boxing piece will be connected to the top chord of the trusses as per Figure 7.32. For half trusses with vertical chords the boxing plate may be attached to either the vertical or horizontal chords as per Figure 7.33.

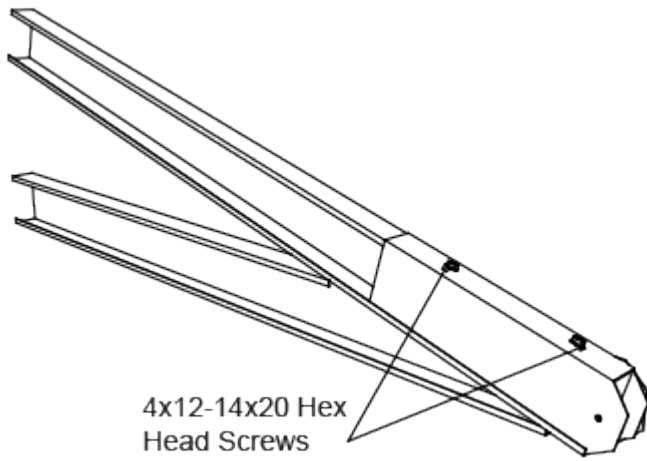

Figure 7.32 figure boxing piece to truss top chord

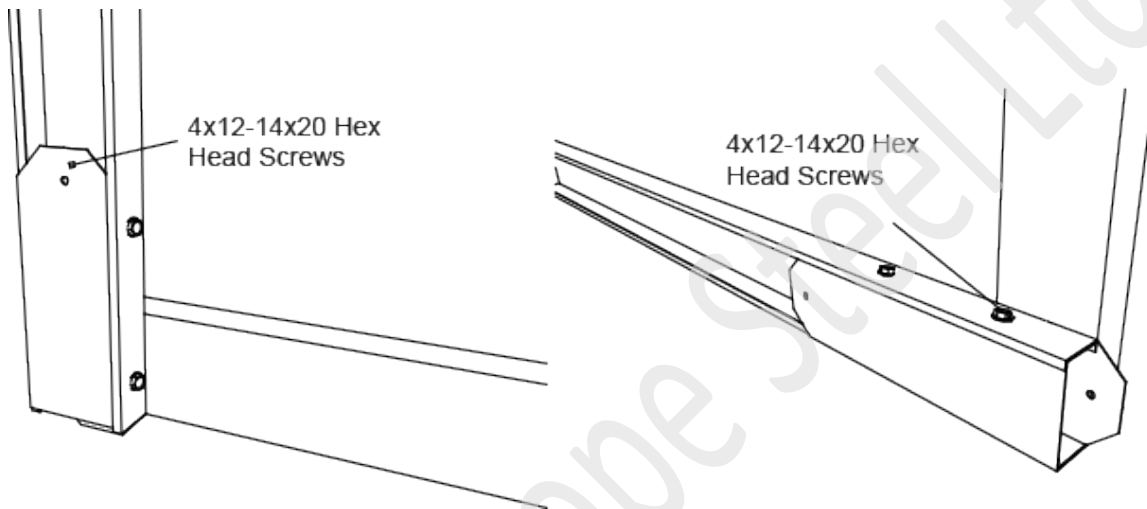

Figure 7.33 200mm boxing piece fixed to either horizontal or vertical chords on a half truss

Tie downs are then fixed to the boxing piece using the quantities of fasteners shown in Table 7.8.4 for the respective tie downs. An example of the tie down methodology is shown in Figure 7.34 for triple grips. Other tie downs are fixed in a similar manner.

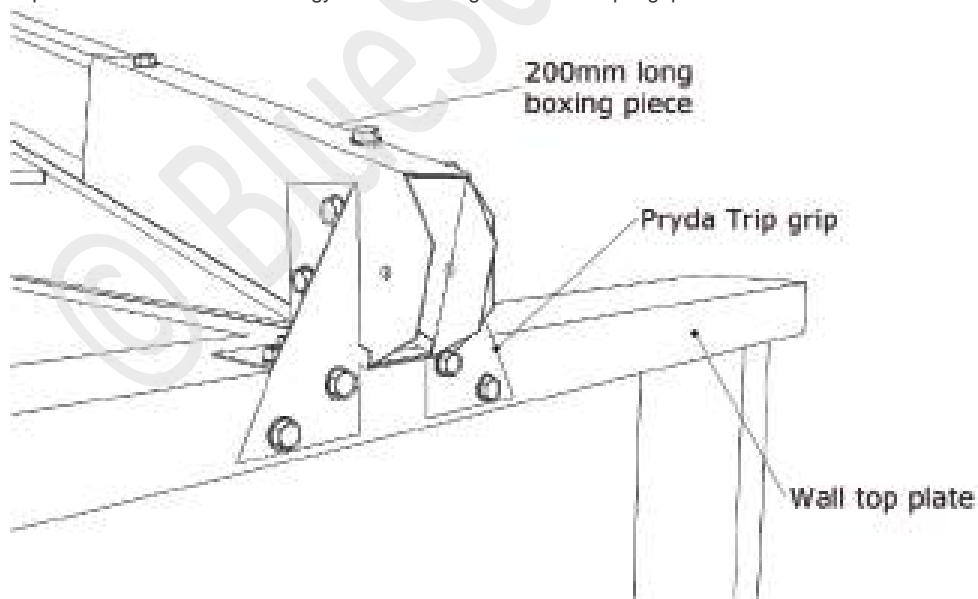

Figure 7.34 Fixing double tie downs to truss and top plate (Triple grips shown)

7.9 Roof bracing

Roof bracing can be broadly classified into four groups:-

1. Temporary bracing for installed top chord
2. Roof cross bracing
3. Bottom chord bracing
4. Web bracing

An example of roof cross bracing is shown in Figure 7.35.

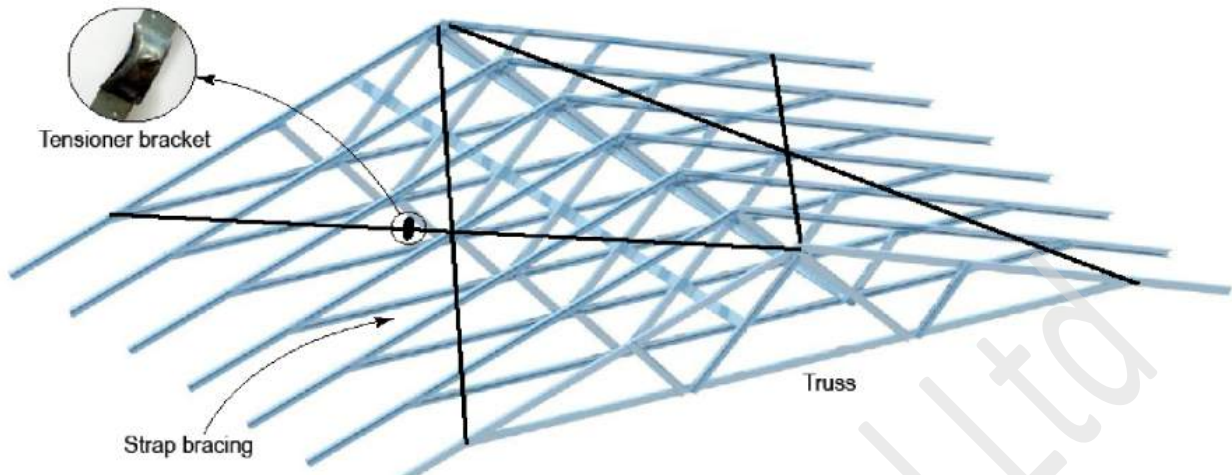

Figure. 7.35 Roof cross bracing using strap bracing

7.9.1 Temporary bracing

Temporary bracing should be in place to support trusses until all bracing is installed. Temporary ties should be made in accordance with Table 7.9.1. Ties should be fixed to each truss with a minimum of one #12-14x20 screw. Steelbrace is not acceptable for temporary bracing.

Temporary braces may be truss or batten sections. Minimum sizes are shown in table 7.9.1 below. Unless requested, temporary bracing materials are not supplied. Care should be taken that supplied parts used as temporary bracing are removed after permanent bracing is installed for use in their intended location.

Table 7.9.1 Size of temporary ties

Truss spacing	To Top Chord	To Bottom Chord
Up to 1200	TOPSPAN@40 x 0.55/ C7555 / C9055 @ maximum 3m spacings	@22 x 0.42/ C7555 / C9055 @ maximum 3m spacings

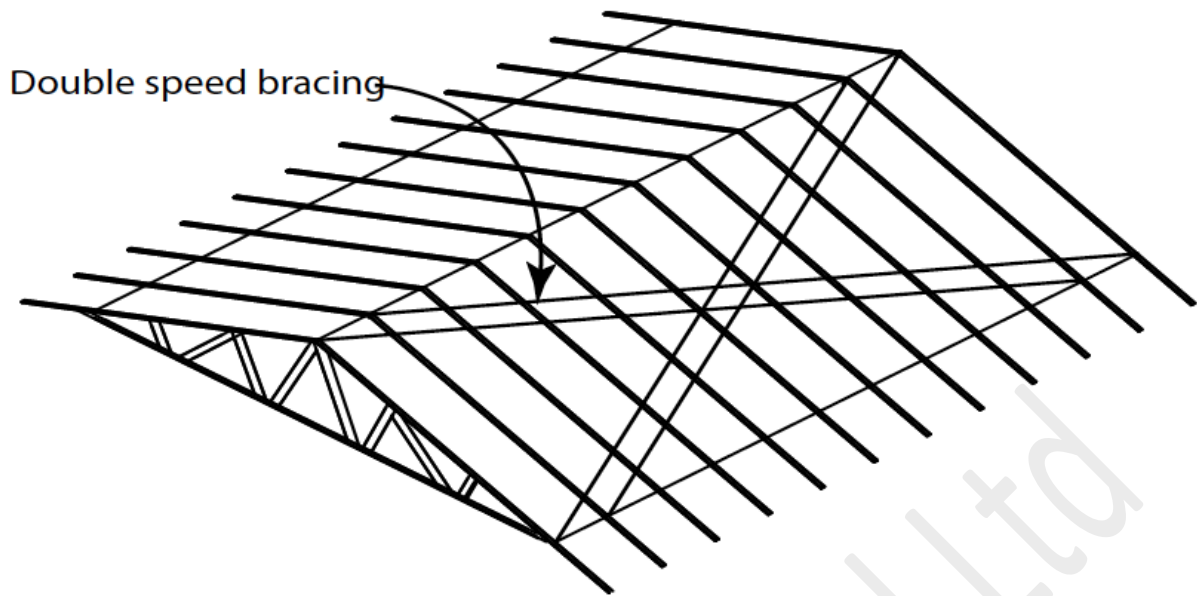

Fig. 7.36 Double speed brace

7.9.2.1 Cross Brace

Speed strap brace must be a minimum 32 x 1.2mm (min.) with minimum tension capacity of 8.4 kN. Bracing may be larger and may have a bend to make installation easier by keeping the bracing straight without any sagging. Proprietary bracing system may be used conforming to AS 4440:2004. Where single speed brace is insufficient, double speed brace needs to be provided as shown in Fig. 7.36. Refer to the table below for single or double speed brace. Strap bracing with tensioners is another form of cross bracing.

7.9.2.2 Fixings

Bracing should be fixed to apex of A-truss as shown in Fig. 7.36b.

Bracing should be fixed to wall top plate adjacent to truss positions as shown in Fig 7.36c. Fix bracing to each intermediate truss using 1 x 12-14x20 hex head screws as shown in Fig 7.36a.

For cantilevered trusses and cut-off/half trusses, bracing should be fixed as shown in Fig 7.36e.

Step 1 Apex fixing

Fasten the brace to the outside edge of the top chord of the gable end truss at the apex and lay it diagonally down the slope, at an angle 30° - 45° to the truss line.

Step 2 Wall fixing

Fix the other end to the outer flange of the top wall plate. Ensure that the trusses are plumb.

Step 3 Tensioning

When all the braces have been installed, check that trusses are plumb and straight, and are effectively tied together with temporary battens. Where strap brace is used, fix bracing to the apex of the first truss and at the wall adjacent to the last truss as shown in Fig. 7.35. Tension bracing before fixing to intermediate trusses with tensioner bracket and fix strap to each truss.

Fix braces to the upper face of the top chord at each intersection.

Figure. 7.36a Brace to chord connection

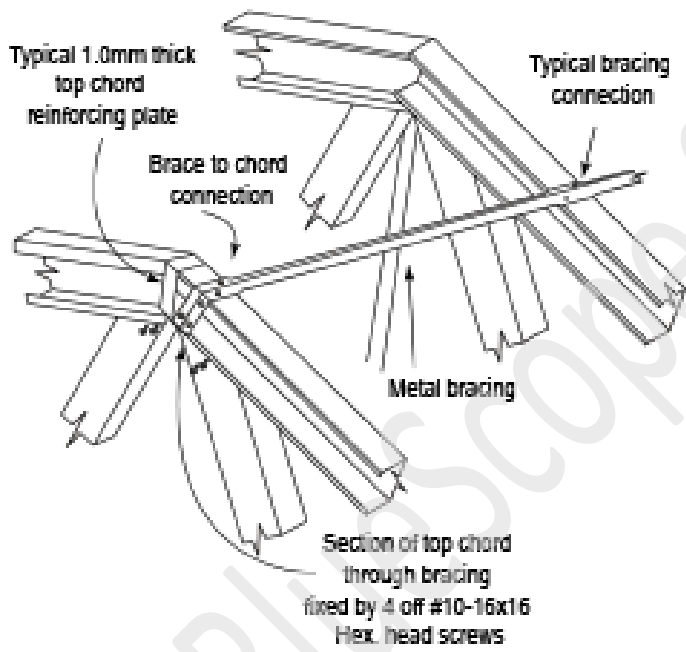
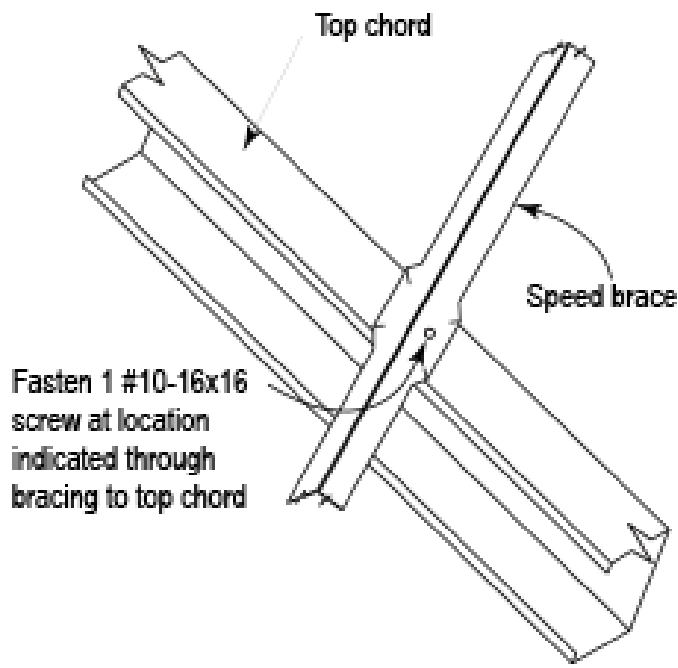

Figure 7.36b End fixing at apex

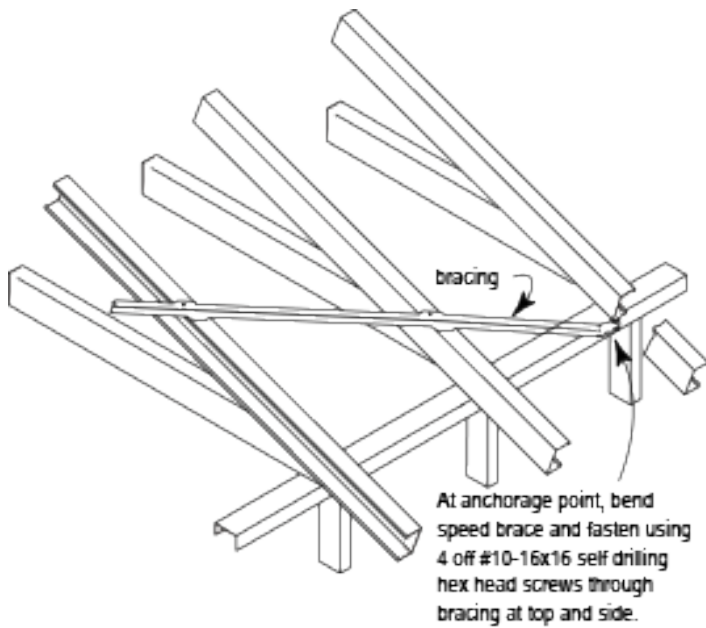

Figure 7.36c Fixing at anchorage point at wall top plate

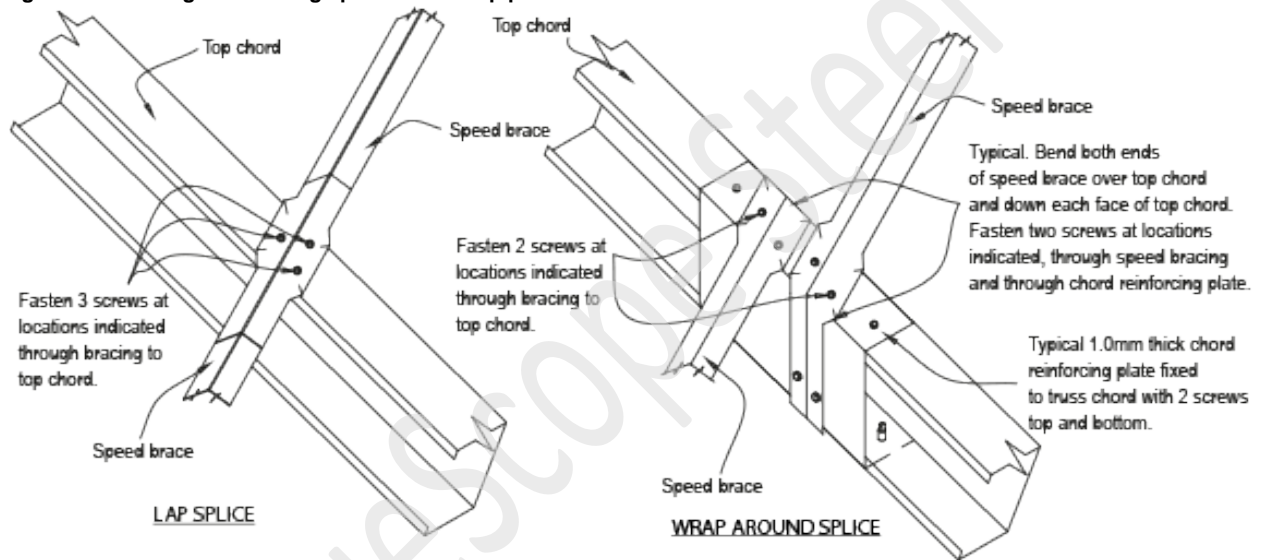
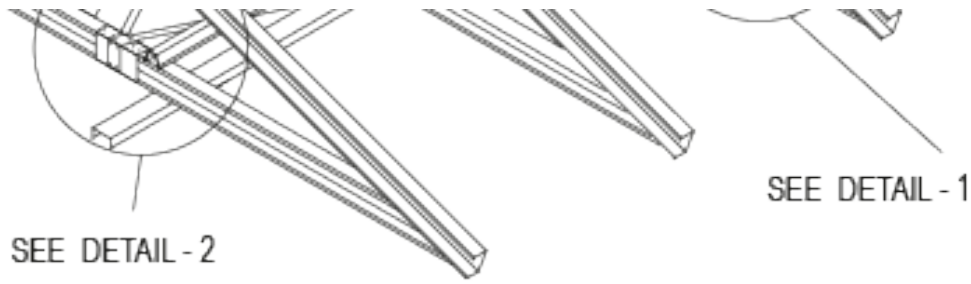

Fig 7.36d Typical splice detail





Locate and fold down speed strap bracing to vertical face of bottom chord of truss. Fasten speed bracing to vertical face of bottom chord with 4 screws.

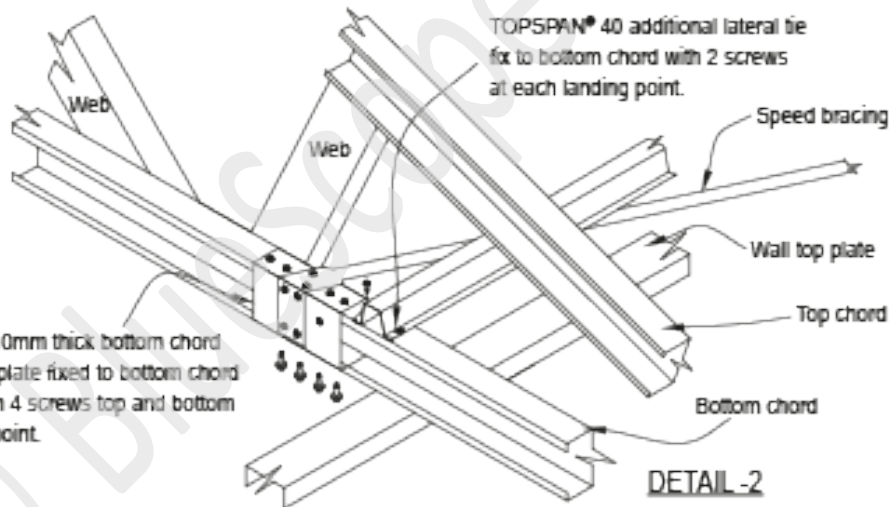
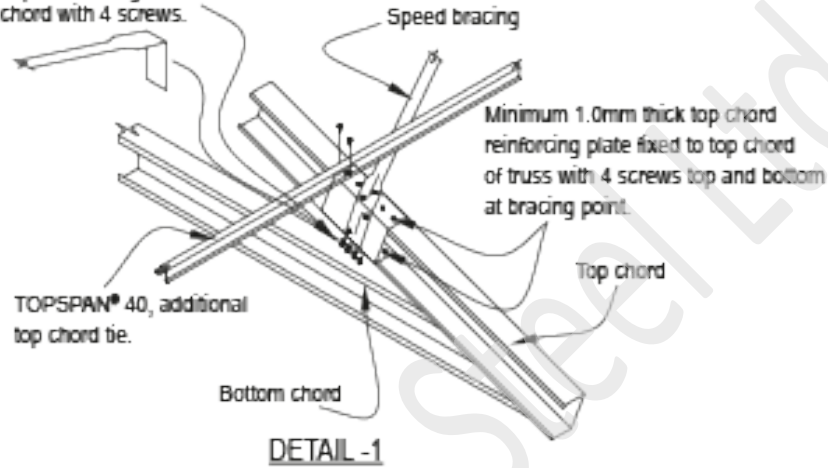
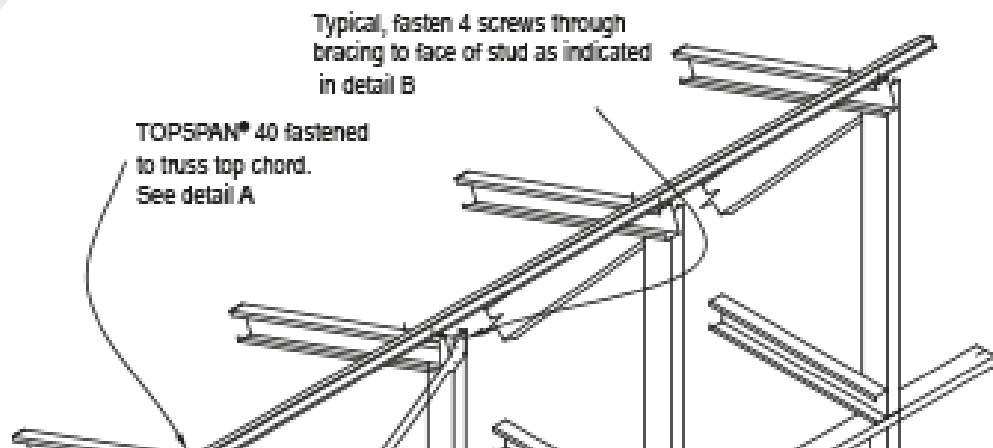

Figure 7.36e Fixing details for cantilevers



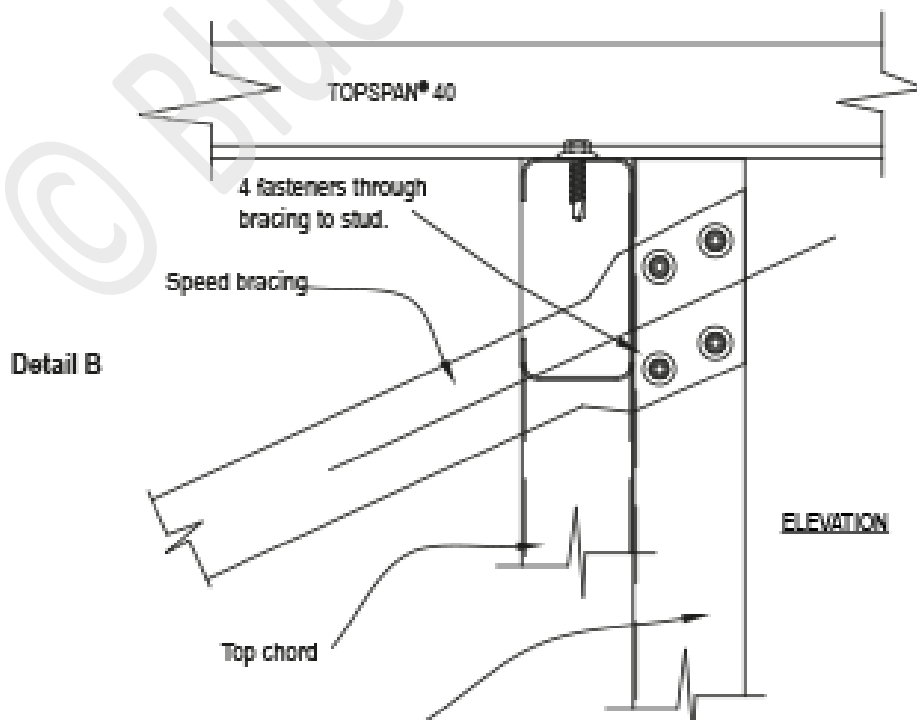
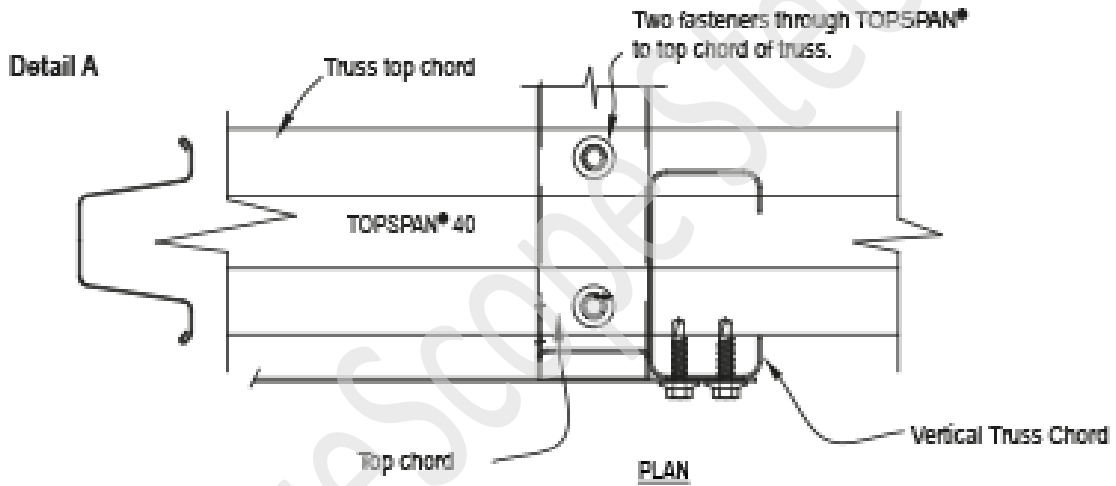
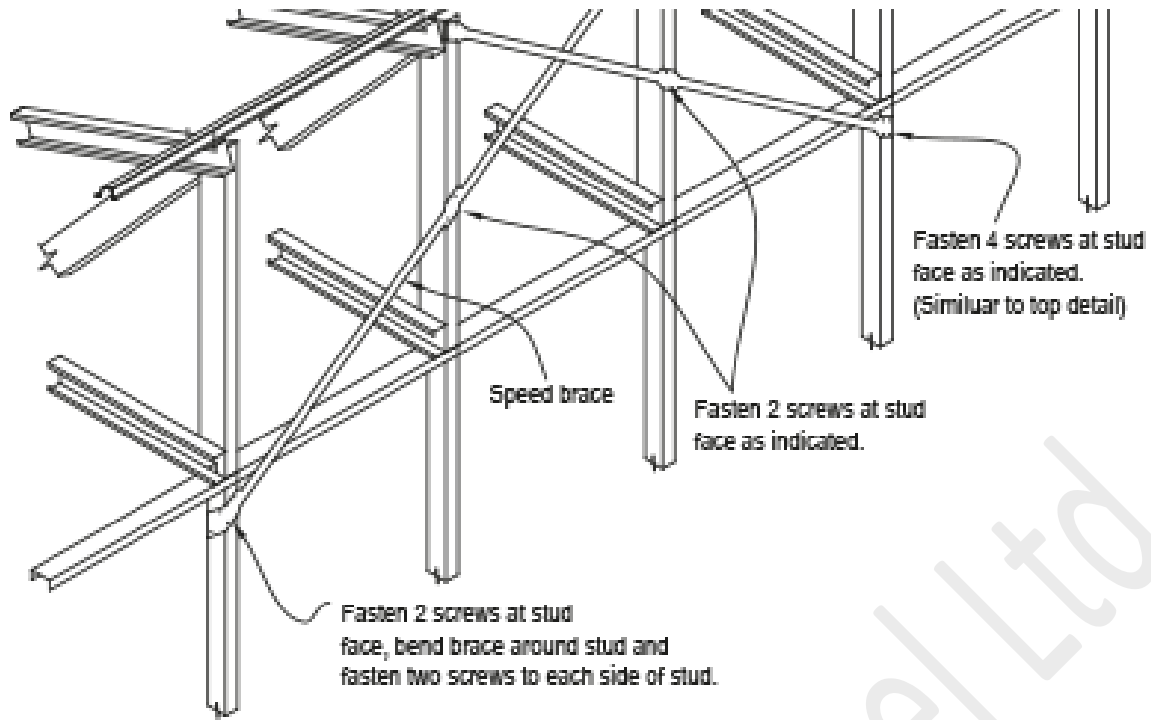

Figure 7.36f Fixing details for cut off or half trusses

7.9.2.3 Bracing Layout

The type and layout of the top chord steel brace are related to the truss span, shape and loading of the roof. The area of the standard truss overhangs is not required to be braced.

7.9.2.3.1 Gable roof bracing layout

© BlueScope Steel Ltd

Truss Spans up to 8m

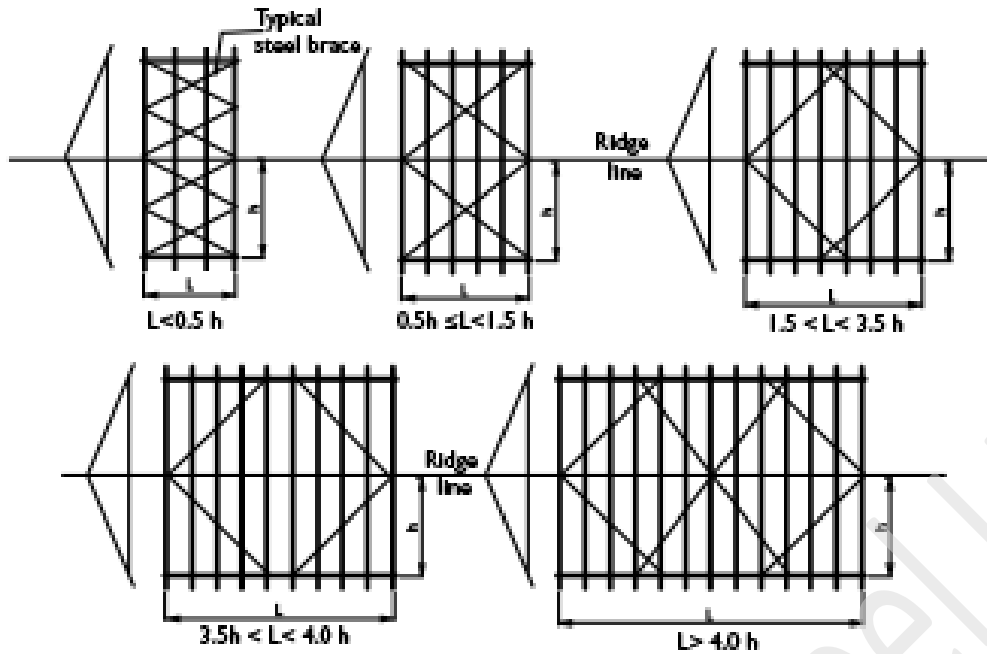

Truss Spans over 8m and up to 13m

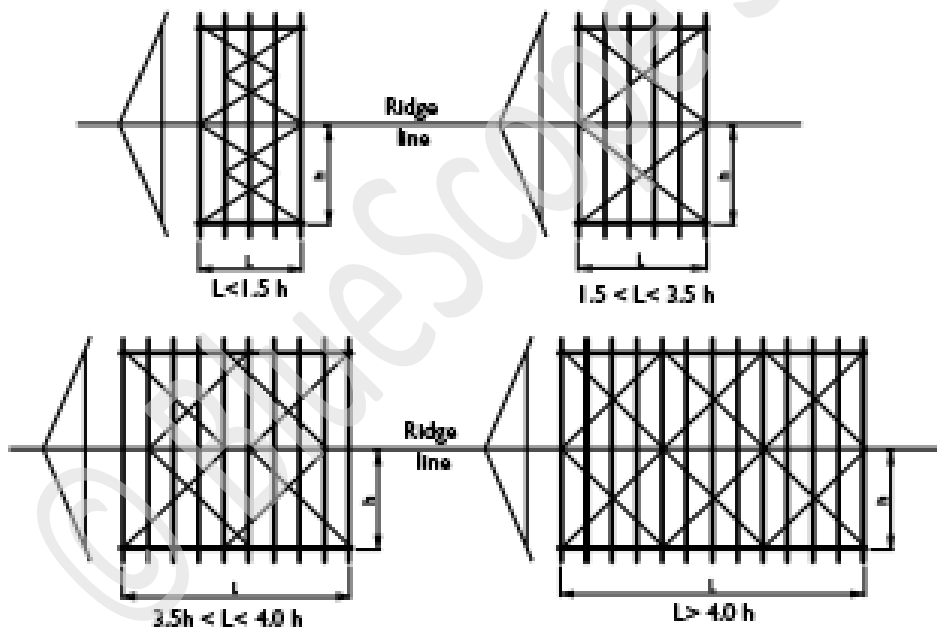

Choose the appropriate bracing pattern based on the size and shape of the roof.

Truss Spans 13 - 16m

Truss Spans 13-16m

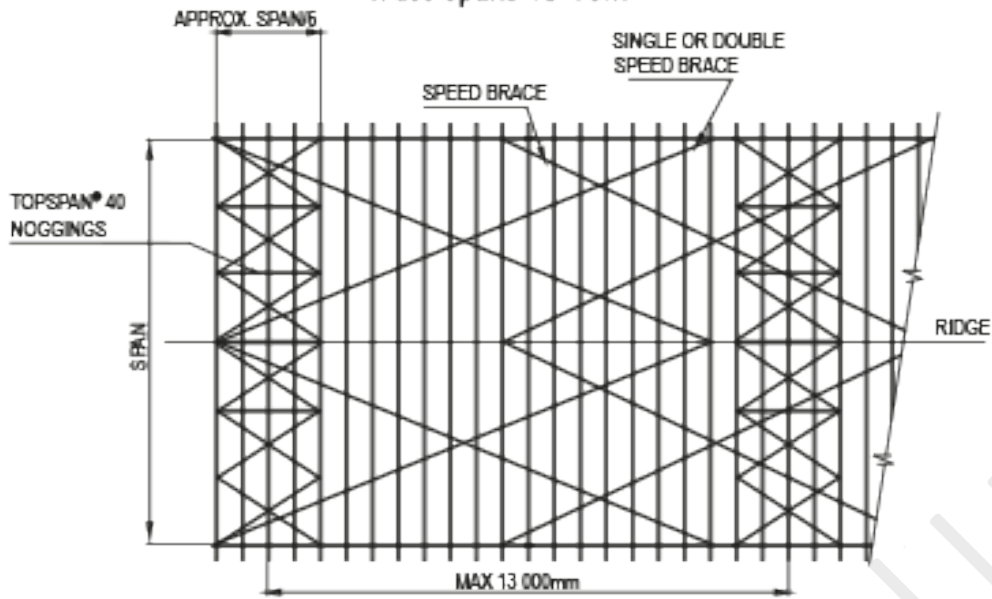

7.9.2.3.1 Hip Roof

For roofs with hip zone, the hip rafter serves as bracing and no additional top chord bracing is required in this zone.

If the portion of the roof between the hip end or Dutch-hip ends (L) is greater than half span of roof truss (h), then the roof shall be braced as per gable roof.

Roof length $L >$ half-span of roof truss, h .

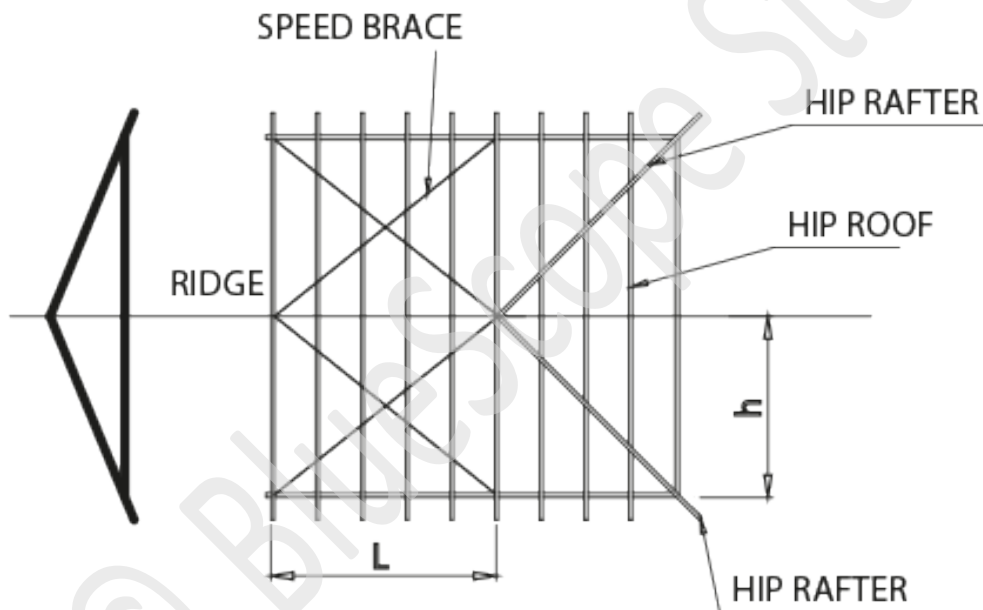

Roof length $L <$ half-span of roof truss, h

Truss Spans up to 8m Truss Spans over 8m and up to 13m Ridge

Roof length $L <$ half-span of roof truss, h

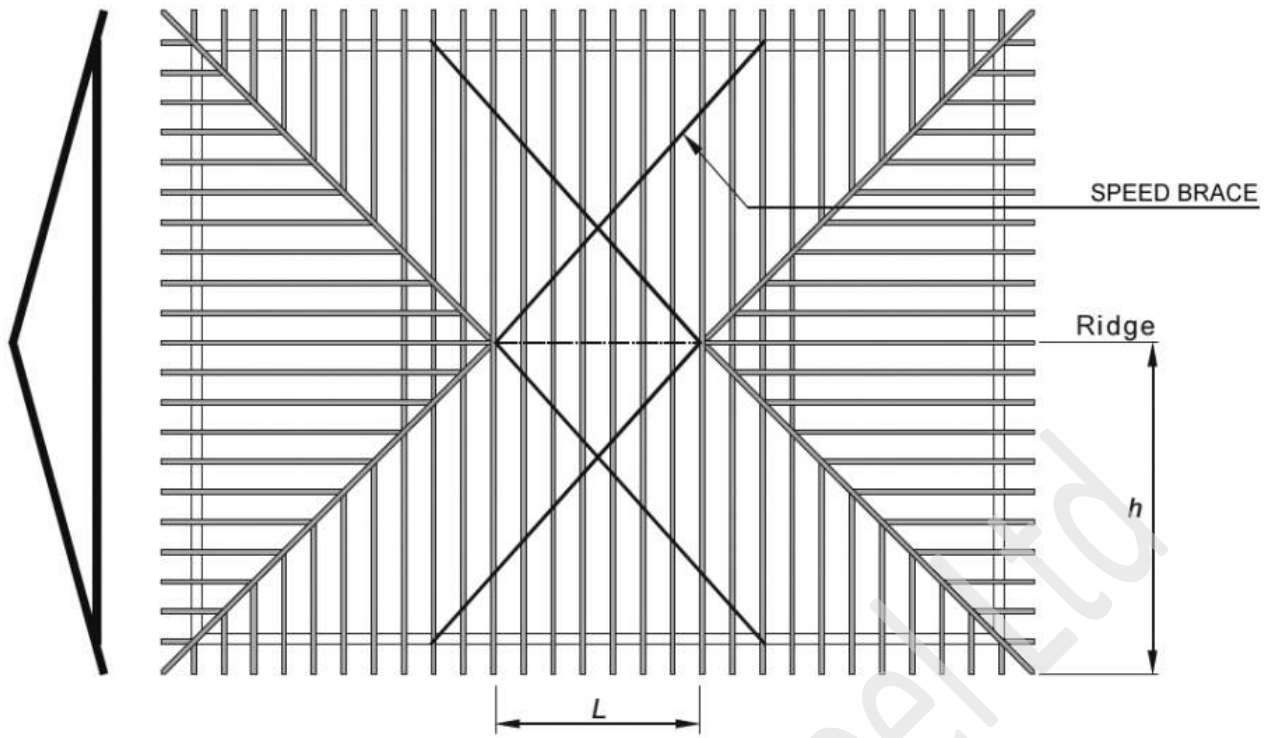

7.9.2.3.1 Dual Pitched Roof

On dual-pitched or cut-off roofs where the ridge line is not central on the building, each side of the ridge shall be considered as a separate case and gable end details shall be applied.

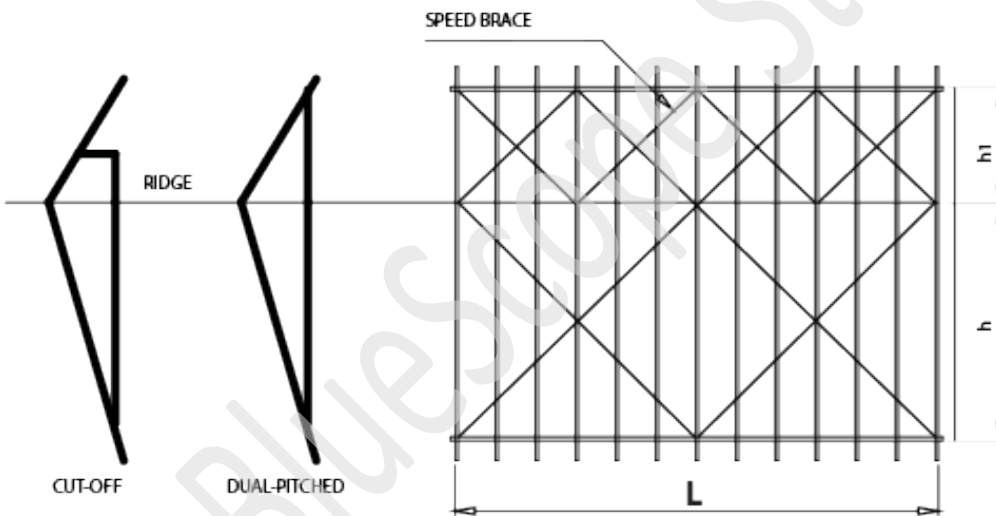

7.9.2.3.1 Bell Roof

For bell trusses, the speed brace should be spliced at the bell breaks as shown below. Refer to Fig. 7.37 for typical steel brace splice detail.

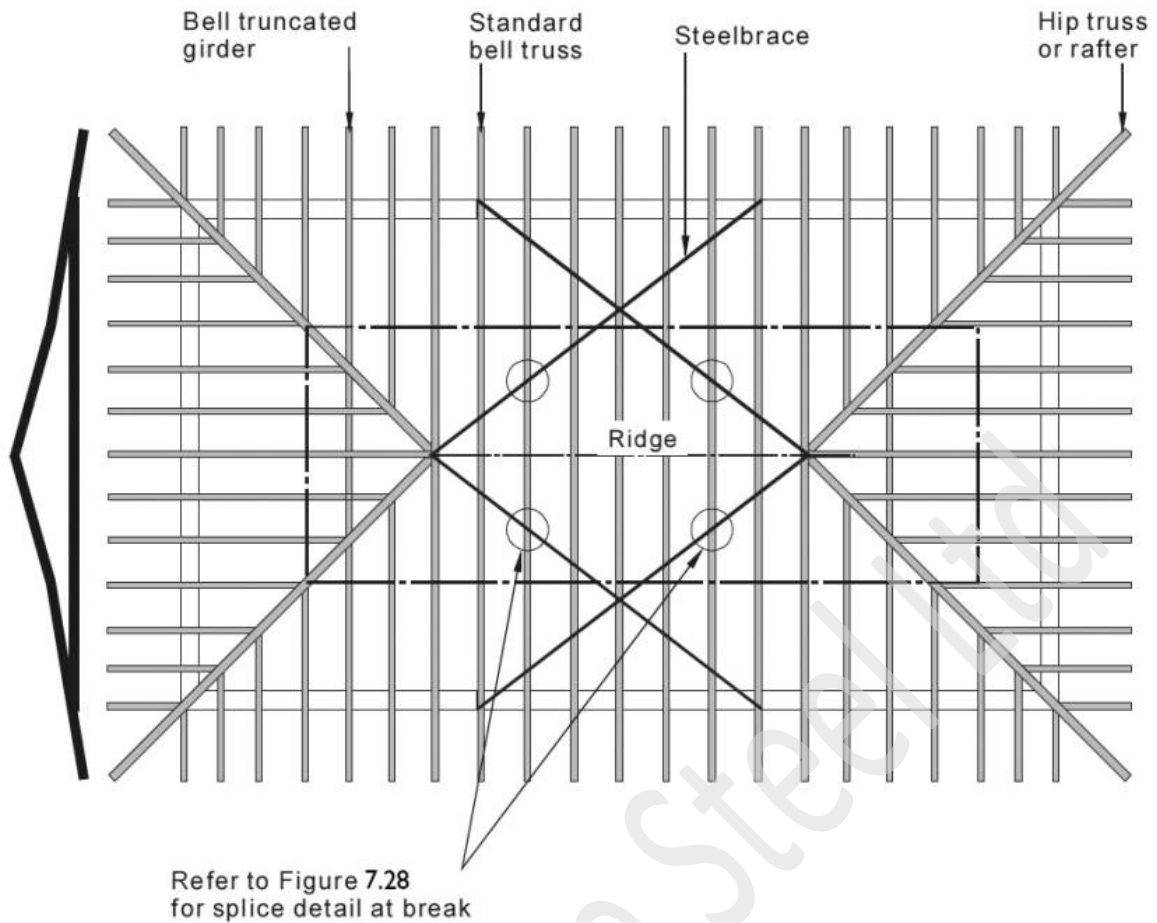

7.9.3 Bottom chord bracing

Bottom chord bracing is required to provide restraint to bottom chords of trusses when they are in compression due to wind uplift. Where ceiling battens are mechanically fixed to the bottom chord of trusses, using screw fasteners the ceiling battens (along with ceiling sheeting) provide adequate bottom chord bracing.

For suspended ceilings, clip on battens or exposed bottom chords where ceiling battens do not provide lateral restraint, bottom chord ties shall be provided.

Bottom Chord bracing consists of bottom chord ties and diagonal bracing.

Bottom chord ties may be roof battens or truss chord material (Minimum TOPSPAN® 22) fixed to each at spacing specified by roof designer and used in the truss design. The diagonal bracing may be minimum 32 x 1.2 strap brace fixed at each end in accordance with the bracing layout, tensioned and then fixed to each intermediate truss bottom chord. Refer to Figures 7.36a and 7.36c for details and numbers of screws.

Ties and bracing to be fixed to supporting walls to transfer bracing loads to the structure.

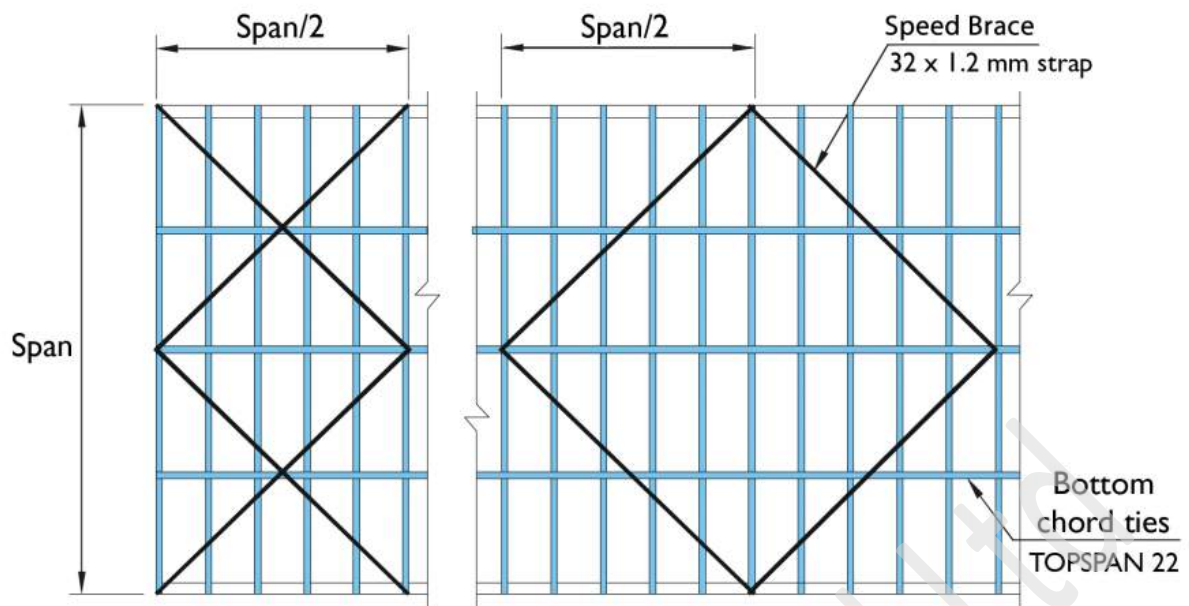

Figure 7.37a Typical bottom chord ties bracing layout

7.9.4 Web bracing

The slenderness and capacity of web members of longer lengths can be enhanced by boxing of sections or by providing lateral restraints. The lateral restraint extends out at right angles to the plane of the truss and along the building and is braced back to the ceiling on roof plane at each end of building. Fig. 7.38 (a) shows ties which are suitable for cases when trusses are parallel to each other and webs of trusses line up. A web rail is suitable when trusses are parallel to each other but the webs do not line up, as illustrated in Fig. 7.38 (b).

Web rails are usually 75 x 38 x 1.0mm or 90 x 38 x 1.0mm channel and the lateral ties are usually specified as TOPSPAN® 40. The Trained Software User will advise if lateral bracing is required. Typical web rail and lateral ties fixing details are shown in Fig. 7.38 (c).

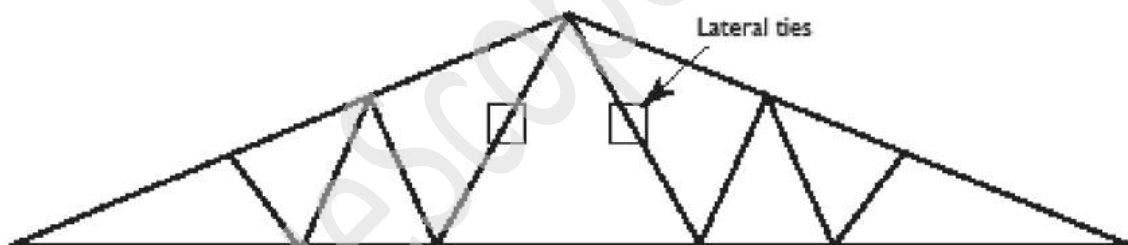

Figure 7.38a

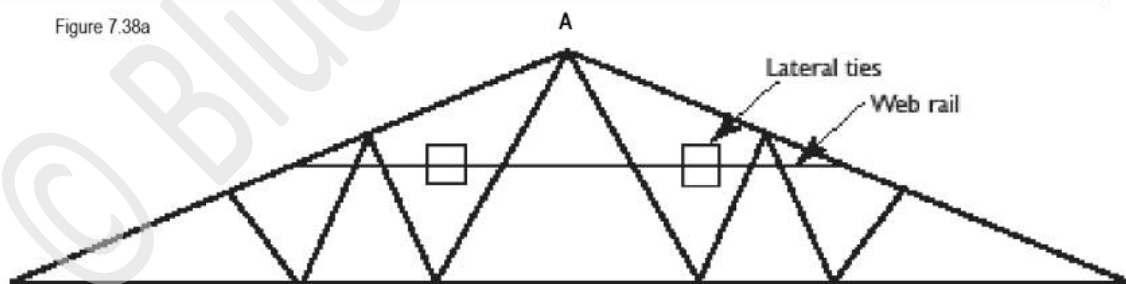

Figure 7.38b

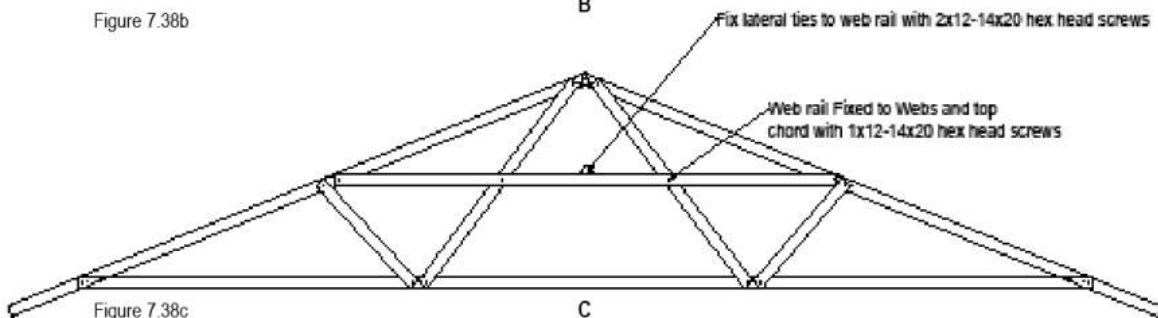

Figure 7.38c

Web rail Fixed to Webs and top chord with 1x12-14x20 hex head screws Fix lateral ties to web rail with 2x12-14x20 hex head screws

7.10 Battens

7.10.1 Ceiling battens and plasterboard angles

Ceiling battens must be fitted immediately after the roof trusses have been installed. By fixing the ceiling battens at this stage the roof trusses will be laterally restrained without the need of bottom chord ties.

STEP 1: When all trusses are erected, install ceiling battens to the underside of the bottom chords. Ceiling battens can be spaced at 600mm centres or 450mm centres depending on the type of plasterboard that will be used for the ceiling (check the specifications). Ceiling batten sizes shall be selected from batten manufacturer's technical literature and sized to suit span, spacings and loads.

NOTE: Ceiling battens spacing is dependent on ceiling lining. For suspended ceilings, lateral restraints must be provided at spacings specified by the building designer.

STEP 2: Fix the ceiling battens with two #10-16x16mm hex head self drilling screws, one into each flange of the batten into the bottom chord of the truss.

STEP 3: Plasterboard angle must be used at the intersection of the ceiling batten/load bearing wall junction to support the ends of the ceiling battens.

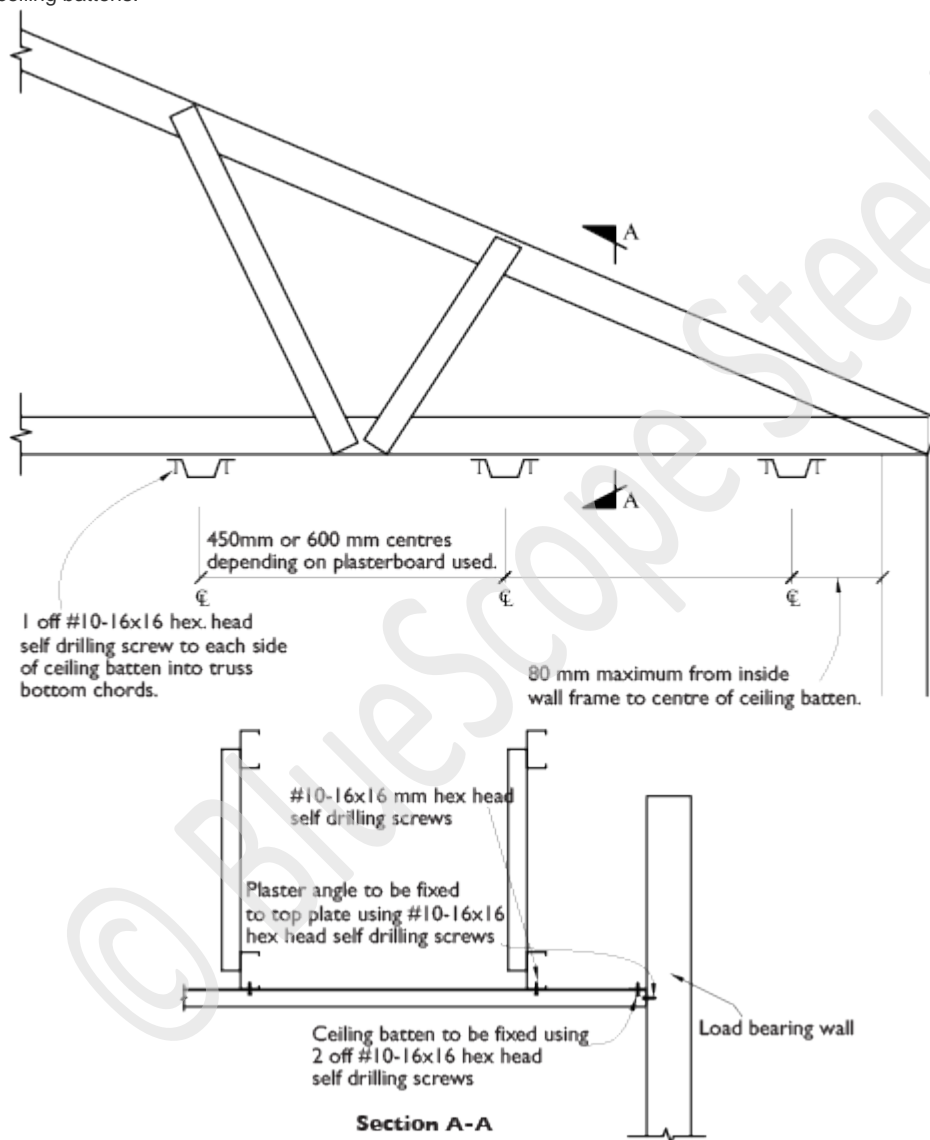

Refer to Figure 7.39a

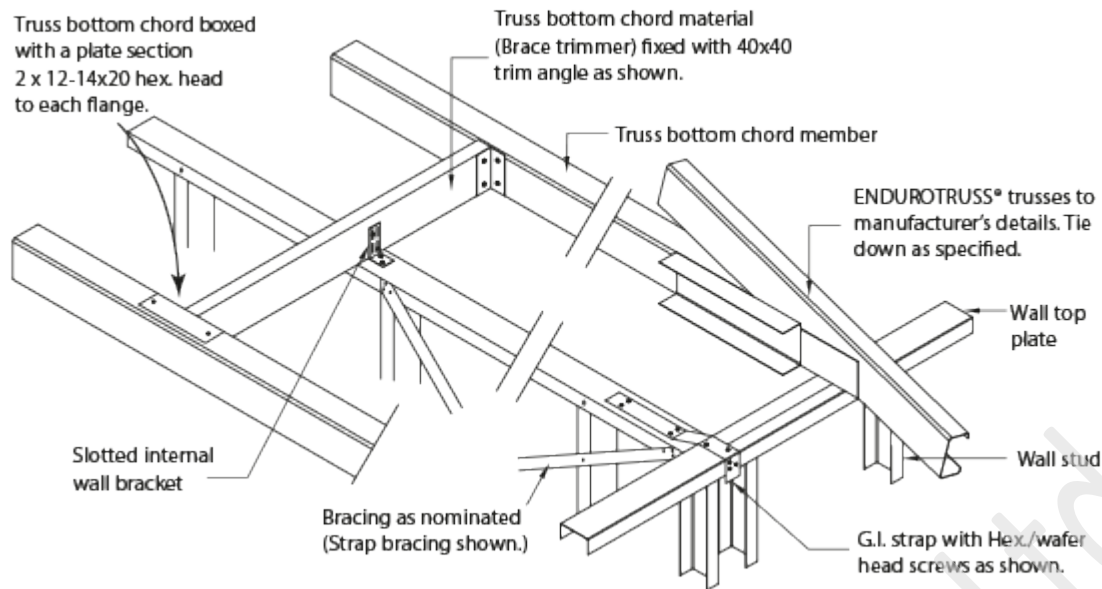

7.10.2 Internal wall support and shear transfer

Figure 7.39b Transfer of Racking Loads to Internal Bracing Walls - Internal Wall Parallel to Trusses

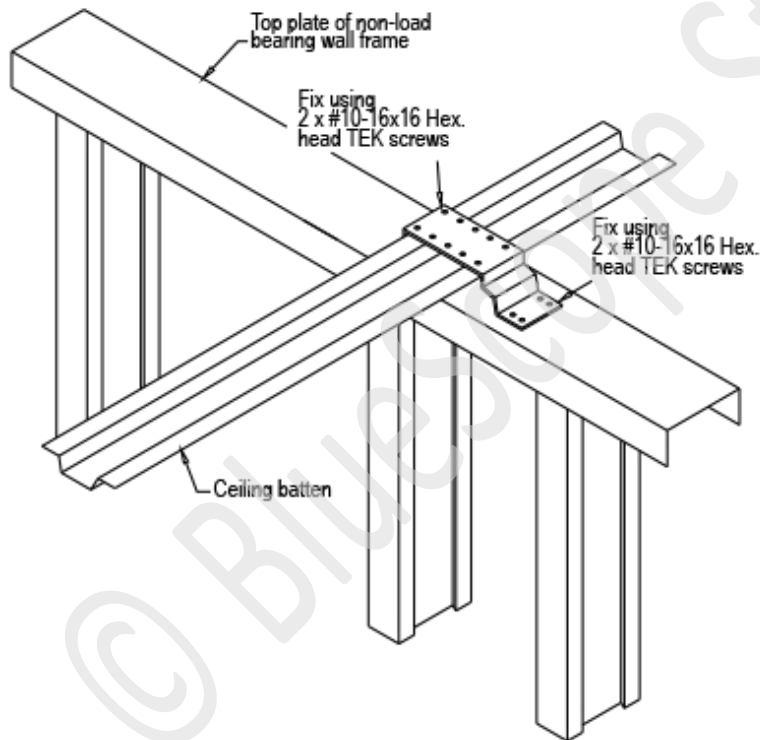

It is important that the truss can move up and down in this bracket so screws should be able to slide. To enable the trusses to slide ensure the fastener is placed in the middle of the slot and it is not over tightened.

For shear transfer, refer to Wall Installation manual.

STEP 4: Fix one #10-16x16mm hex head self drilling screw down through the top of the bracket and into the top of the ceiling batten to stop the bracket sliding.

STEP 5: Bend the bracket down to the top plate of the internal wall and fix two #10-16x16mm hex head self drilling screws through the foot of the bracket into the top plate.

Refer to Figure 7.39a

STEP 6: Install hitch brackets to the bottom chord of trusses at a maximum of 1200mm centres. Fix two #10-16x16mm hex head self drilling screws into the side of the flat face of the bottom chord.

STEP 7: Now fix two #10-16x16mm hex head self drilling screws through the foot of the bracket into the top plate.

Refer to Figure 7.39b

7.10.3 Roof battens and spacings

The bracing of top chords is achieved via the overlying roof battens. Ensure roof batten spacings and fixings provide the restraint assumed in the truss design.

STEP 1: Maximum roof batten spacing is specified by the user in ENDUROCADD® and shown on the output documentation. Batten spacings are usually defined in sheet manufacturer's tables. Batten spacing of 900mm batten centres should be used unless otherwise specified for sheet roofs. Ensure both spacings do not exceed the maximum used by the Trained Software User in the design. Roof batten sizes shall be selected from the manufacturer's technical literature and sized to suit span, spacing and loads.

STEP 2: Fix roof battens to trusses using #10-16x16mm hex head self drilling screws, to both batten flanges at each truss. Roof battens shall be fixed to every truss, including each ply of girder truss.

NOTE: For roofing fix a roof batten each side of the line formed from the intersection of the jack rafters and the chords of the truncated trusses to finish the hip roof line. Use two #12-14x20mm hex head self drilling screws at each intersection.

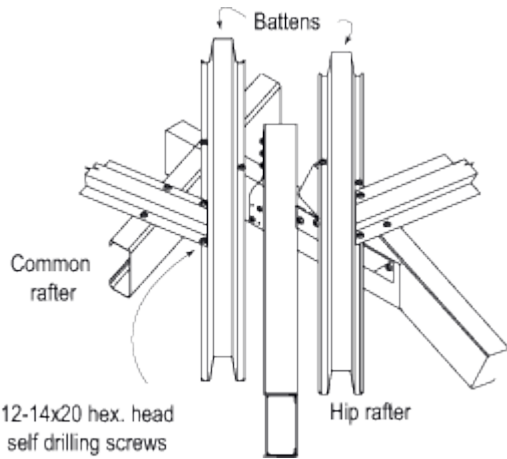

Figure 7.35 Hip rafter and batten arrangement

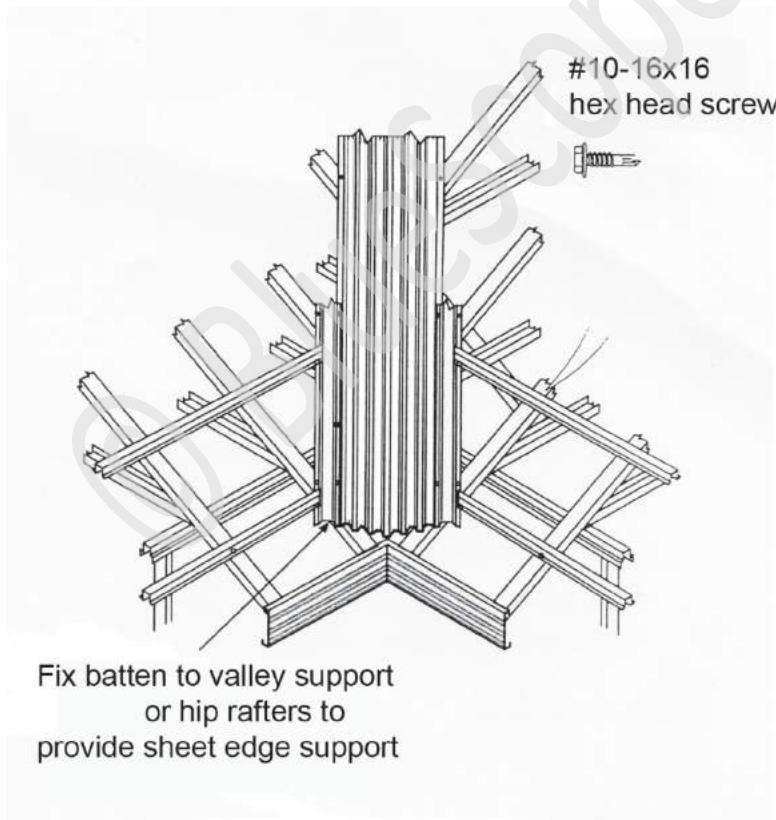











Figure 7.36 Valley gutter arrangement

7.11 Fasteners

The class of fasteners should be as stipulated in AS3566.

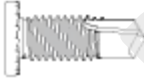

Fasteners used should be BlueScope Steel approved.

The fasteners below are suitable for fixing structural steel frames together, as specified below:

Description		Uses
	5/16" - 12x17 hex head #17-15x15 hex head with trilobular thread forms	Structural connections on trusses
	12-14x20mm hex. head self drilling screw	Structural fixing screw, tiles roof truss fixing, girder/truss heel bracket fixing, roof
	10-16x16mm Wafer head self drilling screws	Flush fixing screw where flush surface finish is required, e.g. Plasterboard® corner angles
	M6.5 - 12 x 42 hex head self drilling screw	Fixing common rafters to truncated truss top chords
	14-10x20mm hex head	Structural fixing screw low wind area
	6-20x50mm CSK wing self drilling screws	Architraves, reveals and skirtings General finishing and fixing timber screw
	6-20x65mm CSK self drilling screws	Architraves, reveals and skirtings General finishing and fixing timber screw
	6-18x30mm bugle needle point self drilling screws	Plasterboard fixing to ceiling battens
	6-20x25mm bugle drill point self drilling screws	Plasterboard fixing to wall frame studs
	8-18x25 SEH extended point self drilling screws	Fibrous cement fixing screw (wet areas)
	M6 x 1P x 18mm Smooth Top Gx Teks Frame Screw	Stiffening stud to plate connections, connecting lintels to plates, and attaching bracing

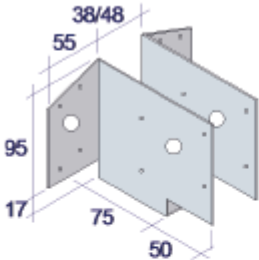
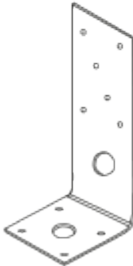
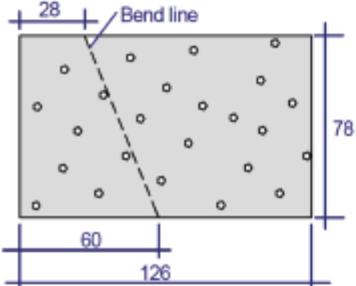
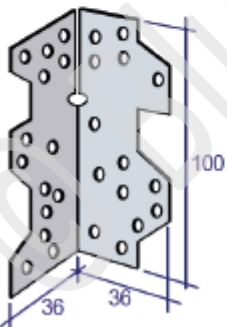
7.12 Components

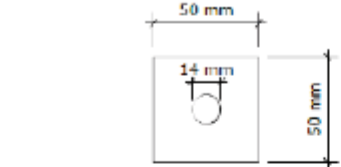
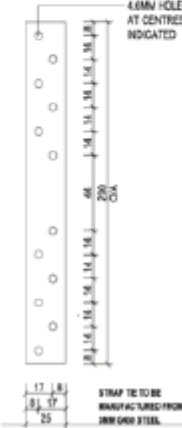
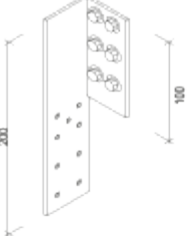
Picture	Description	Application	Supplier
	Bridge Truss Boot TBJ45 1.6mm BMT Zincform G450 Z275	Z275 Bridge Truss Boot	Pryda
	CPAH Hold down bracket 1.9mm BMT Zincform G450 Z275	Hold down bracket	Pryda
	Hip Mitre Plate 1.9mm BMT Zincform G450 Z275	Hip Mitre Plate	Pryda
	Triple Grip (left or right hand) 1.6mm BMT Zincform G450 Z275	Tie Down	Pryda
	MultiGrip	Tie Down	Pryda

Picture	Description	Application	Supplier
 <p>Washer - 5mm thick galvanized steel</p>	50 x 50mm Square Galvanized Washer	Washer For Tie Down	General
 <p>6MM HOLES AT CENTRES INDICATED</p> <p>STRAP TO BE MANUFACTURED FROM JMW 5000 STEEL</p>	25 x 3 x 200mm Steel Tie-Down Strap	Combination Heel and Truss Tie-Down Plate	
 <p>50 x 50 x 3 x 200mm Notch Equal Angle Tie-Down-Left and Right</p>	50 x 50 x 3 x 200mm Notch Equal Angle Tie-Down-Left and Right	Combination Heel and Truss Tie-Down Plate	
 <p>Transition Section Connection</p>	Transition Section Connection	Truss Tie-Down	ENDUROFRAME
 <p>Apex Plate</p> <p>Type C Apex</p>	Apex Plate	Type C Apex	ENDUROFRAME

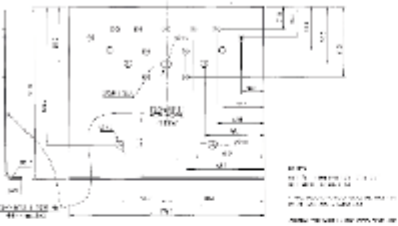
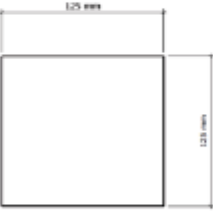
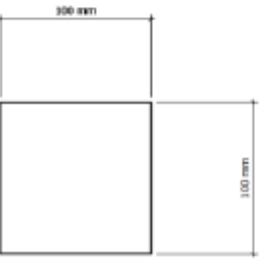
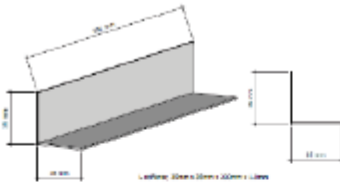
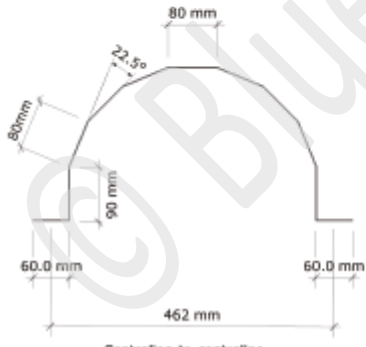
Picture	Description	Application	Supplier
	25 x 3 x 200mm Steel Tie-Down Strap	Elbow Bracket	Pryda
	Heel and Knee Stiffening Plate 125x125x1.5 for 90mm System	Heel and Knee Stiffening Plate	Pryda
	Heel and Knee Stiffening Plate 100x100x1.5 for 75mm System	Heel and Knee Stiffening Plate	ENDUROFRAME
	Knee Stiffener For Type C 35mm x 35mm x 200mm x 1.0mm		
	Angle lintel - 200 x 35 x 1.5mm Galvanized Section Minimum 90mm Long	Truss Web Stiffener	
	All holes are in center of the barrel and are located 37.5mm from the end for a C75 truss or 45mm for a C90 truss. Height 300, thickness 1.5 mm material.		

8.0 Definitions of terms

Gable ladder: A pre-fabricated panel used to form a gable overhang.

Common Rafter: A member on a hip end supported by truncated trusses and supporting roof battens.

Creep Rafter: A member on a hip end supported by the hip rafter and end wall supporting roof battens.

Hip Rafter: A prefabricated member from channel section running down the hip ridges supporting creeper rafters and battens.

Whaling Plate: A length of chord section fixed to the outside face of a dutch gable truss to support common rafters.

Bridge Bracket: Connects a bridge truss to a girder truss.

Wind Bracing: Bracing fitted diagonally over the roof plane from the top plate to the ridge line to transfer bracing loads in to the supporting structure.

Bottom Chord Tie: A section fixed at right angles to the bottom chord to provide lateral restraint.

Temporary Braces: Structural sections used to brace trusses in position before the application of permanent bracing. Temporary bracing must be fastened for solid support.

Bottom Chord Tie: A section fixed at right angles to the bottom chord to provide lateral restraint.

Bracing Strap: Light-gauge metal strap 25x1 used to brace roof frames. Two straps diagonally opposed on one plane form one brace.

Bracing- Roof: Bracing fitted diagonally over a roof plane from the top plate to the ridge line to transfer bracing loads in to the supporting structure.

Bracing Wall: Component fixed to the face of a wall panel to provide shear strength in the plane of the wall. Bracing may be Strap, Panel or K type.

Chords: Steel components forming the external perimeter of a truss.

Cladding: Wall or roof lining- Covering to structural frame to provide weather protection to the building.

Dutch Gable (Dutch Hip): A block end type where the rafter face is truncated by a vertical face some distance back from the hip end pitching line.

Eave Block: A block outside the building pitching perimeter defining the extent of rafter or truss top chord extension past the pitching line

Gridlines: A series of equal spaced vertical and horizontal reference lines with origin at the building Start point. They offset in both polar directions towards the 2 ends of the building. Grid-lines may form the basis of stud-spacing, truss spacing or wall cladding joint location.

Heel: The truss connection at an end support point.

Hip Line: The interface between block faces where the difference between the 2 adjoining block top faces is more than 180 degrees

Load Bearing Wall: A wall which carries vertical loads from the construction above and or lateral loads resulting from the wind. Internal or external walls may be load bearing.

Non-Load Bearing walls: Internal walls which do not support roof or floor loads are considered non load-bearing. However Internal walls may be used as lateral bracing walls and are required to resist internal wind pressures.

Panel Point: The connection point of a truss web to a chord.

Pitching line: The external perimeter of a buildings roof. It is the intersection between the bottom of a truss bottom chord and the bottom of a truss top chord or for cut off or half trusses of the bottom chord and the external face of the end chord. It is often aligned with the external face of an external wall.

Rafter Crown: A rafter positioned at the centre of a standard hip face running from the intersection point of the hip lines to the outside edge of the eave block.

Rafter Face: A top face of a roof block whose battens are supported by rafters. Standard faces are triangular and extend over the entire width of a rectangular block end.

Rafters - Creeper: Rafters positioned in a hip that are not supported by trusses but by hip rafters, load bearing walls or fascias only.

Rafters - Common: Rafters positioned in standard locations extending from hip rafter to fascia supported by truncated trusses.

Rafters - Hip: Hip rafters provide rafter and batten support at the edge of a rafter face where the difference between the 2 adjoining block top faces is more than 180 degrees.

Rafters - Valley: Valley rafters provide rafter and batten support at the edge of a rafter face where the difference between the 2 adjoining block top faces is less than 180 degrees.

Ridge: The interface between two block faces where the difference between the 2 adjoining block top faces is more than 180 degrees.

Shear wall: This is the structural system consisting of flat tensile braces, studs and hold-down connectors. It is used to resist racking loads and is discretely placed within a wall panel to transfer racking loads to the foundation. Wall breakpoints should NOT be placed within the location of a shear wall brace.

Soffit: The finished underside of a roof overhang or porch ceiling that covers the rafter bottoms or eaves.

Truss Station: In a Hip end the truss station is its position from the hip end pitching line expressed in terms of mm or truss spans. eg where trusses are spaced at 600mm centres the first or 600mm station truss is placed 600mm from the hip end pitching line.

Valley End: A combination of Girder Truss supporting bridge trusses in an adjoining roof block and Saddle trusses forming the ridge line between the 2 blocks.

Valley Line: The interface between two block faces where the difference between the 2 adjoining block top faces is less than 180 degrees.

Webs: Steel Members that join the top and bottom chords of a roof or floor Truss, which form triangular patterns usually carrying tension or compression forces.

Trained Software User: A person who has been through a structured training program under the supervision of an approved trainer. That person must hold a current certificate from BlueScope Steel stating they are qualified to design and detail residential structures, utilising the ENDUROCAD® software, which are fit for manufacture and erection.

9.0 References

AS4055: 2011 Wind Loads for Housing

AS4440: 2004 Installation of nail plated timber roof trusses

AS3566.1: 2002 Self-drilling screws for the building and construction industries

NASH Handbook Low Steel Framing, National Association of Steel Framed Housing 2011

NASH Standard - Residential and Low Rise Steel Framing: Part 1, Design Criteria, National Association of Steel Framed Housing 2005

AS1397:2011 Steel sheet and strip - Hot-dipped zinc-coated or aluminium/zinc-coated - Continuous hot-dip metallic coated steel sheet and strip - Coatings of aluminium, zinc and magnesium

Disclaimer, warranties and limitation of liability

This publication is intended to be an aid for all trades and professionals involved with specifying and installing

ENDUROTRUSS® products and not to be a substitute for professional judgement.
Except to the extent to which liability may not lawfully be excluded or limited, BlueScope Steel Limited will not be under or incur any liability to you for any direct or indirect loss or damage (including, without limitation, consequential loss or damage such as loss of profit or anticipated profit, loss of use, damage to goodwill and loss due to delay) however caused (including, without limitation, breach of contract, negligence and/or breach of statute), which you may suffer or incur in connection with this publication.

© Copyright BlueScope Steel Limited 27 April 2016
Information, brochures and your local distributor:

www.enduroframe.com

BLUESCOPE, TOPSPAN, TRUECORE ENDUROFRAME, ENDUROTRUSS, ENDUROCADD and ENDURO are all registered trademarks of BlueScope Steel Limited, ABN 16 000 011 058. Pryda®, BattenZip® and Tek® are registered trademarks of ITW Australia Pty Ltd.

LikeBe the first to like this

No labels

© BlueScope Steel Ltd