

ENDURO FRAME[®]

ENDUROTRUSS[®] Roof System Installation Manual



The smart, simple solution to roof framing.



ENDUROTRUSS® Roofing System Installation Manual

- 1.0 Scope of manual
 - ENDUROTRUSS® Product performance
- 2.0 On-site handling
 - 2.1 Slings
 - 2.2 Roof trusses exposure and storage
- 3.0 Tools & equipment
- 4.0 Points for construction
- 5.0 Truss identification
- 6.0 Truss Assembly
 - 6.1 ENDUROTRUSS® Framing System marking and branding
 - 6.2 Chord to chord connection identification
 - 6.3 Fasteners
 - 6.4 ENDUROTRUSS® Framing System assembly
 - 6.4 ENDUROTRUSS® splicing
 - 6.4.1 Splicing of Boxed Chords
 - 6.4.2 Splicing Boxed Chords
 - 6.5 ENDUROTRUSS® Framing System stiffening and re-inforcement
 - 6.5.1 Web stiffening
 - 6.5.2 Apex stiffening
 - 6.5.3 Heel Stiffening
 - 6.5.4 Knee Stiffening
 - 6.5.5 Web Stiffening
 - 6.5.6 Chord Boxing
 - 6.5.7 Web Boxing
 - 6.5.8 Web Supports
 - SUP Connection
 - SUP A Connection
 - SUP B Connection
 - SUPB-F Connection
 - 6.5.9 Elbow Stiffening
 - 6.6 Boxed Eaves
- 7.0 Roof construction
 - 7.1 General and design
 - 7.1.1 Prior to construction
 - 7.1.2 Internal load bearing
 - 7.1.3 Fasteners
 - 7.2 Roof truss set-out
 - 7.3 Gable End Construction
 - 7.4 Hip End Construction
 - 7.4.1 Type 1 Hip construction
 - 7.4.2 Type 1A Hip construction
 - 7.4.3 Type 2 Hip Construction
 - 7.4.4 Truncated trusses
 - 7.4.5 Hip Rafter Construction
 - 7.4.5.1 Boxed Hip Rafters
 - 7.4.5.2 Veed Hip Rafters
 - 7.4.5.3 Hip Truss
 - 7.4.6 Common Rafters
 - 7.4.6.1 Common Rafters on Dutch Gables
 - 7.4.7 Crown Rafters
 - 7.4.8 Creeper Rafters
 - 7.5 Dutch gable construction
 - 7.6 Valley end construction
 - 7.6.1 Girder-bridge truss connection
 - 7.6.2 Saddle truss construction
 - 7.6.3 Support for Lower Valley Ends
 - 7.6.4 Radial Roof
 - 7.7 Common roof block construction
 - 7.8 Truss and Rafter Tie Down Connections
 - 7.8.1 Boxed Tie Downs
 - 7.9 Roof bracing
 - 7.9.1 Temporary bracing
 - 7.9.2 Cross Bracing
 - 7.9.2.1 Fixings
 - 7.9.2.2 Bracing Layout
 - 7.9.2.3 Gable roof bracing



ENDUROTRUSS-InstallationManual.j

- layout
 - 7.9.2.4 Hip Roof
 - 7.9.2.5 Dual Pitched Roof
 - 7.9.2.6 Bell Roof
 - 7.9.3 Bottom chord bracing
 - 7.9.4 Web bracing
- 7.10 Battens
 - 7.10.1 Ceiling battens and plasterboard angles
 - 7.10.2 Internal wall support and shear transfer
 - 7.10.3 Roof battens and spacings
- 7.11 Fasteners
- 7.12 Components
- 8.0 Definitions of terms
- 9.0 References

General notes to be read before you use this manual:

1. This Manual has been prepared for a range of roof framing designs using ENDUROTRUSS® building components manufactured or supplied by BlueScope Steel, its licensed manufacturers or dealers.
2. The ENDUROFRAME® Building System has been designed as a complete framing system.
3. All erection and connection details must be made in accordance with the relevant standard connection drawing details contained in this manual or its supplements, or drawings output from the ENDUROCADD® software.
4. Before commencement of any fabrication or construction develop a safety management plan to cover key risks. Key risks include, but are not limited to:
 - a. Working at heights
 - b. Electrical safety
 - c. Cuts and scratches
5. Consider and install the appropriate level of safety equipment to manage identified risks. Safety equipment that may be required includes:
 - a. Personal protective equipment including safety glasses, gloves, hearing protection (when using power tools) and sunscreen;
 - b. Appropriate fall protection equipment including guard rails, scaffolds, ladders, elevated platforms, safety mesh, and fall restraint harnesses
6. A temporary earth should be established during the construction of steel frames and, upon completion, the steel house frames must be permanently earthed in accordance with the requirements of local electricity authorities.
7. You should check with your local workplace health and safety authority to see what safety measures you need to put in place prior to and during construction. It is the responsibility of the installer/erector to ensure all local safe work practices are adhered to and the safety of the whole site is maintained at all times.
8. For wiring in steel wall frames, nylon grommets shall be installed to run electrical cables through.
9. Where insufficient detail is included in this manual for your project, seek specialist advice.
10. Before you commence construction:
 - a. You should check with your local government authority to see if any form of prior permission or approval is required;
 - b. If you want to build or construct any attached structure, you should seek advice from a suitably qualified engineer to verify the capacity of your existing structure to withstand any additional load arising from the attached structure. You should also check with your local government authority to determine any specific requirements for the attachment to existing structures;
 - c. You should check with your local workplace health and safety authority to see what safety measures you need to put in place prior to and during construction. It is the responsibility of the installer/erector to ensure all local safe work practices are adhered to and the safety of the whole site is maintained at all times.
 - d. Contact info@enduroframe.com.au
11. Refer to <http://www.truecore.com.au> for locations where the ENDUROFRAME® Building System can be warranted.

Important disclaimer about this construction manual

Date of Issue

This manual was issued on September, 2014. BlueScope Steel may make changes to this Manual in its sole discretion. You should check you are using the current version of the Manual before you start construction. Refer to <http://www.enduroframe.com> to check version.

Conditions of Use

If you use this manual, you acknowledge and agree that your use is subject to the terms and conditions in this manual. BlueScope Steel, its agents, officers, employees, subcontractors or consultants make no representations, either expressed or implied, as to the suitability of the information and data in this manual for your particular purposes. It's your responsibility to ensure the design you use is appropriate for your needs, the products you have purchased, your site and structural limitations and your building and construction capabilities. It is recommended that you obtain qualified expert advice.

Use of Genuine Materials

Structures in this manual must only be built or constructed using those genuine ENDUROTRUSS® building components made from TRUECORE® steel and made with the ENDURO® rollformer or recommended third party products. Except as otherwise provided in these terms, any warranties only apply to you (if at all) if you use the genuine BlueScope Steel or recommended third party products and method of construction.

Check Delivery

It is important that you check all materials delivered to site against your invoice before you use them in your building or construction to ensure all components have arrived, are of the appropriate quality and are ready for installation.

Limitation of Liability

By using this manual, you accept the risks and responsibility for all losses, damages, costs and other consequences resulting directly or indirectly from using this manual. Except to the extent to which liability may not lawfully be excluded or limited, BlueScope Steel will not be under or incur any liability to any person for any direct or indirect loss or damage (including, without limitation, consequential loss or damage such as loss of profit or anticipated profit, loss of use, damage to goodwill and loss due to delay) however caused (including, without limitation, breach of contract, negligence, breach of statute and/or in equity), which may be suffered or incurred in connection with this Manual.

All rights reserved. No part of this brochure may be reproduced, stored in a retrieval system, or transmitted in any form or by any means, electronic, mechanical, recording or otherwise, without written permission of BlueScope Steel Limited. ABN 16 000 011 058.

1.0 Scope of manual

This manual has been prepared for the construction of a trussed roof within the following parameters:

- Only ENDUROTRUSS® Framing System components made from TRUECORE® steel and made with the ENDURO® rollformer can be used
- Erection details cover construction for cyclonic and non-cyclonic buildings. (See Table below.)
- Other spacings may require additional engineering
- Trusses suitable for both sheet roof cladding and tiled construction.

This installation manual covers the installation according to the following wind classifications, roof types and truss spans.

Table 1 - Wind categories covered by this installation manual

Wind Classification	Truss Spacing	N1	N2	N3	C1	C2	C3	C4
Tiled Roof	600mm	Y	Y	Y	N	N	N	N
	900mm	Y	Y	Y	N	N	N	N
	1200mm	Y	Y	Y	N	N	N	N
Sheet Roof	600mm	Y	Y	Y	Y	Y	Y	Y
	900mm	Y	Y	Y	Y	Y	Y	Y
	1200mm	Y	Y	Y	N	N	N	N

Y = yes N = no

ENDUROTRUSS® Product performance

The ENDUROTRUSS® Framing System has been designed in accordance with relevant Australian Standards and the requirements of the Building Code of Australia 2013.

The roof framing system will perform as specified by the ENDUROCAD® 2013 software output documentation if installed in accordance with the recommendations and details set down in this manual and related references.

This manual contains vital information. **PLEASE READ IT CAREFULLY.**

For more information and technical support, contact: info@enduroframe.com.au

Maximum Design Gust Wind Speed (Vh) at Height (h)

Wind Classification	Maximum design gust wind speed (Vh)	
	Serviceability limit state (m/s) (Vh,s)	Ultimate limit state (m/s) (Vh,u)
N1	26	34
N2	26	40
N3	32	50
N4	39	61
N5	47	74
N6	55	86

C1	32	50
C2	39	61
C3	47	74
C4	55	86

Taken from AS4055-2012 Page 5 Table 2

The ultimate roof framing solution

The ENDUROTRUSS® Framing System is your opportunity to gain the competitive edge in roof construction - with added peace of mind.

It is a hassle-free and competitive system delivering a superb job without the need for specialist 'steel skilled' site labour.

You benefit from:

- ENDUROTRUSS® Framing System parts are unique, and the design is patented to keep you ahead
- On-site you receive exactly what you need — no wastage
- Just-in-time delivery means you get what you want — when you want it — and there is less likelihood of damage on site
- The ENDUROTRUSS® Framing System uses the ENDUROCAD® roof design software package, a sophisticated design and detailing package
- The ENDUROTRUSS® system is self locating eliminating the requirement for jigs to assemble even hip rafters have pre-punched holes to self-align with truncated trusses on site
- The ENDUROTRUSS® Framing System only requires fastening on one side which greatly speeds up assembly
- Trusses can either be factory or site assembled giving flexibility in delivery and installation of trusses
- Fully engineered and certified, light-weight steel roof framing
- Parts can be linked together which assists in finding and sorting components for assembly, or pre-cut for factory assembly off the rollformer
- Roof designs for most shapes of roof and ceilings
- All parts are inkjet marked making identification simple
- Easy site assembly that requires minimum skill
- The ENDUROTRUSS® system is installed similar to timber trusses making installation by timber crews simple, using standard timber brackets available for some connections;
- Available in back to back or in-line 'flush' format to reduce the volume on a truck when assembled
- Accurate dimensions

The steel framing advantage

Steel house framing has been well established in Australia for many years. Steel house frames and ENDUROTRUSS® roofing frames are safe and stable – above all:

- They don't rot or warp
- Geometrically complex trusses can be considered due to the self-jigging nature of the trusses
- They are light and easy to erect
- They provide you with very flat roof planes
- They are pre-cambered for straight ceiling lines
- They can be site assembled by people with minimal skill

Who uses The ENDUROTRUSS® Framing System?

Any builder who wants to deliver a quality job at a competitive price.

How does the ENDUROTRUSS® Framing System work?

The heart of the ENDUROTRUSS® Framing System is the patented steel truss which is computer designed and manufactured. The computer system does everything from designing the framing, to supplying the documentation, to controlling the manufacturing equipment.

Simply give your drawings to an ENDUROTRUSS® Framing System Trained Software User and they will do the rest. We input your design data and computer-controlled roll-formers produce the required parts.

How do you use ENDUROTRUSS®?

Apart from the drawings and certification mentioned above, you get delivered to your building site the lengths of roll-formed section required for every truss (and the screws). There are no mistakes because the parts only fit one way, and all parts have identification marks printed directly onto the steel.

Before starting installation, carefully read this installation manual. Further information on fabricating and installation of the ENDUROTRUSS® Framing System can be obtained from videos which can be found at www.enduroframe.com.au/building/assembly_and_installation_videos

Fabrication check sheets and quality control sheets that demonstrate the quality control requirements for assembling the ENDUROTRUSS® system are available from your local ENDUROTRUSS® manufacturer or by contacting info@enduroframe.com

All installation shall be done in accordance with this manual.

Framing System market difference

Make the great leap forward

Read the contents of this Installation Manual and discover how the ENDUROTRUSS® Framing System can work for you.

The ENDUROTRUSS® Framing System only requires fastening on one side which greatly speeds up the assembly process.

When designed and manufactured correctly, the trusses are certified to comply with the structural engineering software requirements of the BCA.

2.0 On-site handling

2.1 Slings

Trusses must be fully supported in either horizontal or vertical planes when being transported. Care must be taken when tying down and lifting trusses not to put an excessive pressure on chords, webs or joints. For transporting trusses in horizontal planes where a solitary Trusstite screw is used in a chord to web connection, an additional screw may be inserted to provide additional stiffness, especially for "flush" trusses.

Most trusses for single storey work may be lifted by hand, however where craning is required, sling trusses or truss pieces from top chord panel points as shown in **Figure 2.1**. Slings should be located at equal distances from truss centre lines and be approximately one-third to one-half the truss length apart.

The angle between the sling legs should be 60 degrees or less and where truss spans are greater than 9000 mm, spreader bar should be used.

Where a truss span exceeds 9000 mm, a spreader bars with attachment to web-chord should be used. Never lift trusses by the apex joint alone.

Note: When manoeuvring any materials by hand, take care not to damage components. Components should be inspected on arrival to site. Damaged components may affect structural integrity.

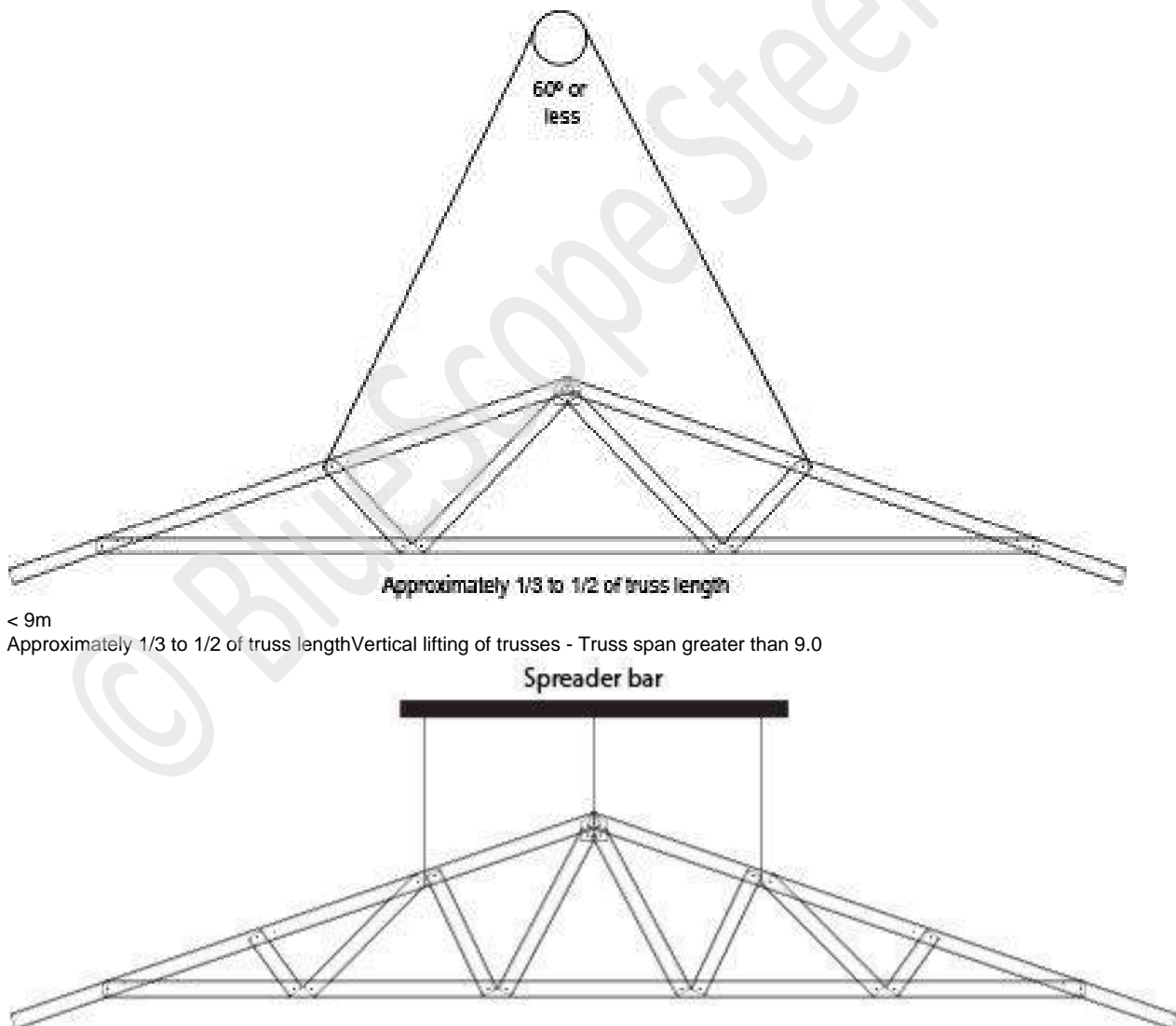

Figure 2.1 Handling

2.2 Roof trusses exposure and storage

Where trusses are stored on site, they should be blocked above firm ground so that they do not come into contact with the soil and to protect them from ground water:

1. If the trusses are stored horizontally, as shown in **Figure 2.2**, the blocking should be at 2.0m to 2.5m centres or as required at joints, to prevent bending of the trusses. Avoid using copper, chemically treated timber or EPDM based materials as blocking.
2. If the trusses are stored vertically as shown in **Figure 2.3**, they should be supported at the designed support locations or bottom chord panel points, and in a manner that will be prevented from tipping or toppling.
3. The truss chords should be sloped such that water drains off.

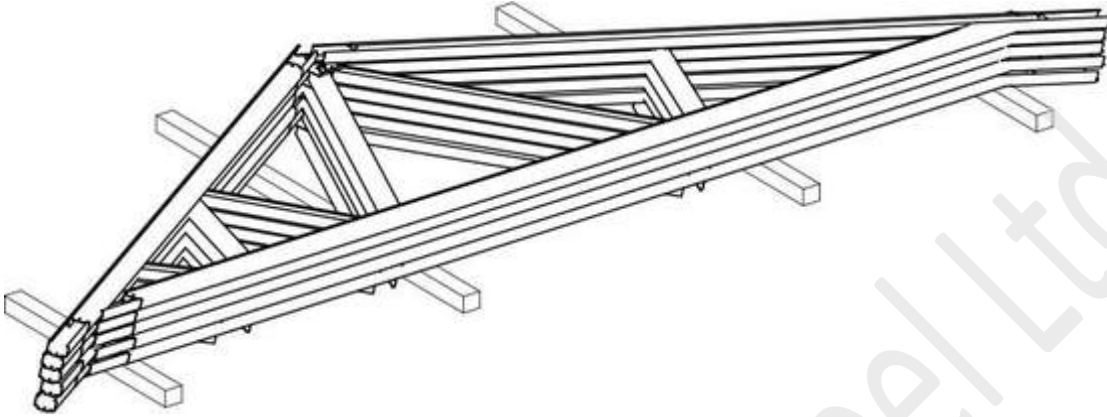

Figure 2.2 Trusses stacked horizontally

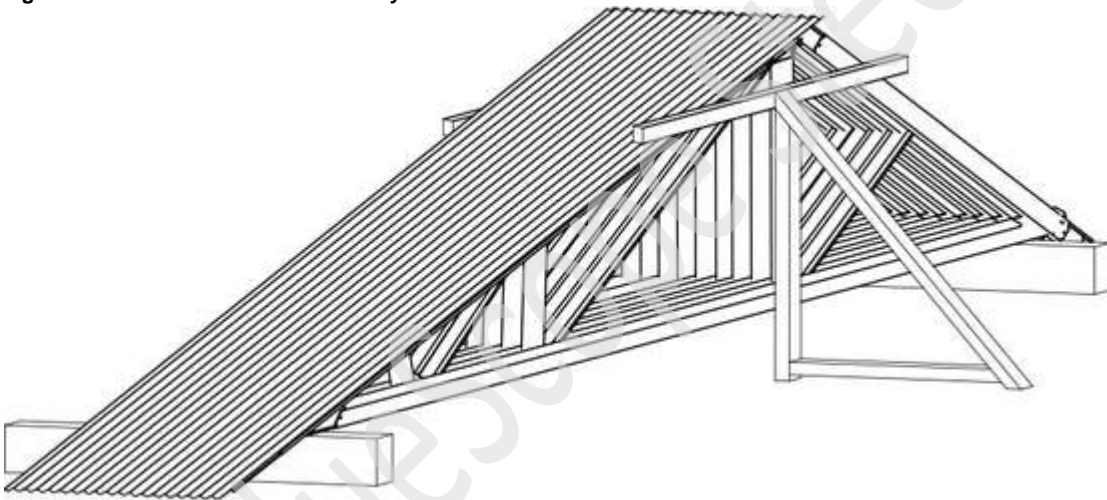

Figure 2.3 Trusses stacked vertically

3.0 Tools & equipment

Required On-site Equipment

When erecting an ENDUROTRUSS® Framing System, the following tools and safety equipment may be required.

Power Tools

- screw gun
- metal cutting saw
- hand held metal cutting saw
- angle grinder

Tool Accessories

- 8mm (5/16") hexagon socket
- Magnetic nutsetter or extension bar (length up to 150mm)
- Suitable metal cutting blade
- 8mm spanner or socket

Hand Tools

- double action tin snips

- Locking sheet metal pliers
- spirit level preferably magnetic
- chalk line
- step ladder
- vice grips
- measuring tape

Essential Safety Equipment

- eye protection (safety goggles)
- hearing protection (when using power tools)
- protective gloves
- earth leakage circuit breaker for electrical goods
- all protection harness
- scaffolding, ladders, etc.



Angle grinder



Tin snips



Locking sheet metal pliers



IRWIN.

Compare

Irwin Impact 5/16" x
100mm Magnetic Nutsetter

Magnetic nutsetter



IRWIN.

Compare

Irwin 76-120mm Magnetic
Screw Guide

Magnetic Screw Guide



Measuring tape



Screw gun



Metal cutting saw



Hand held metal cutting saw

4.0 Points for construction

Trusses must be installed plumb and straight

While erecting the roof, trusses must be fixed plumb and straight. After fixing, if a bow or tilt is evident, the trusses have not been installed correctly. In this case, the problem must be rectified before proceeding further.

THE TRUSSES MUST NOT BE MODIFIED ON SITE WITHOUT FIRST SEEKING ADVICE FROM A TRAINED SOFTWARE USER OR ENGINEER.

Correct direction of ENDUROTRUSS® chord profile

The direction of the channel section used for the chord should be as depicted on Truss Assembly diagrams in (see Figure 5.11.) Trusses should be oriented as shown on the truss layout drawing provided and ensure load bearing points shown on the assembly drawings align with load bearing walls.

Material specification

ENDUROTRUSS® sections are roll-formed from TRUECORE® steel complying with AS1397:2011. The standard ENDUROTRUSS® sections are shown in **Figure 4.1**. In the grade shown, the number prefixed with G indicates minimum yield stress in MPa; and the number prefixed with Z or AM indicates minimum coating mass in g/m².

- 0.55mm BMT, TRUECORE® G550 AM150 steel
- 0.75mm BMT, TRUECORE® G550 AM150 steel
- 1.00mm BMT, TRUECORE® G550 AM150 steel
- 1.20mm BMT, TRUECORE® G500 AM150 steel

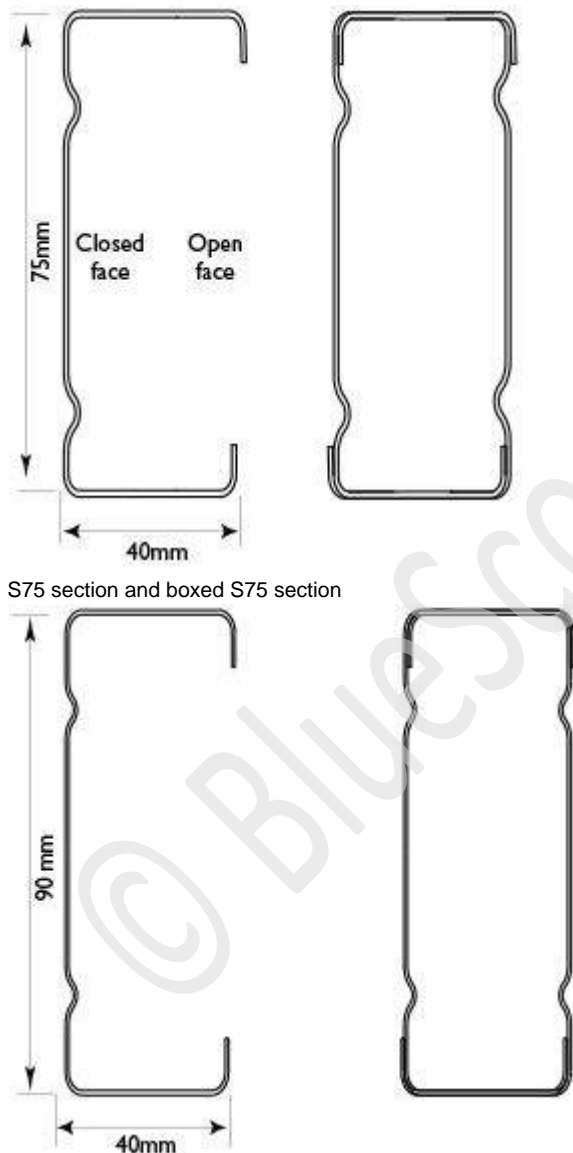

S100 section and boxed S100 section
Figure 4.1 Section types

Straightness

Trusses and rafters must be installed with an overall out of plane straightness not greater than L/500 where L is the length of the member as shown in **Figure 4.2**.

Differential in vertical bows between adjacent members must not exceed 1/150 of their spacing or 6mm whichever is less.

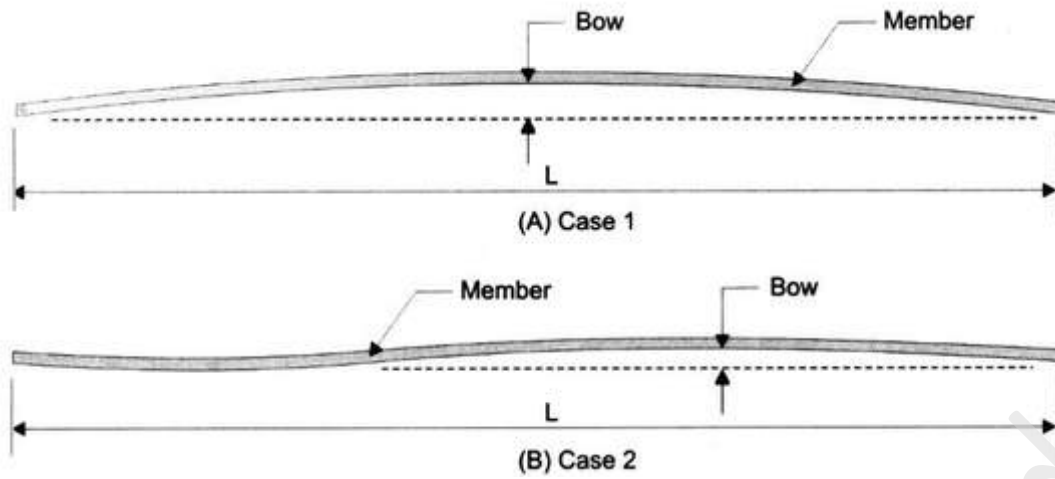

Figure 4.2 Straightness

Plumb

Out of plumb at any point along the length of the truss from top to bottom, must not exceed the minimum of $h/100$ or 20mm unless the trusses are specifically designed to be installed out of plumb. (See Figure 4.3 below)

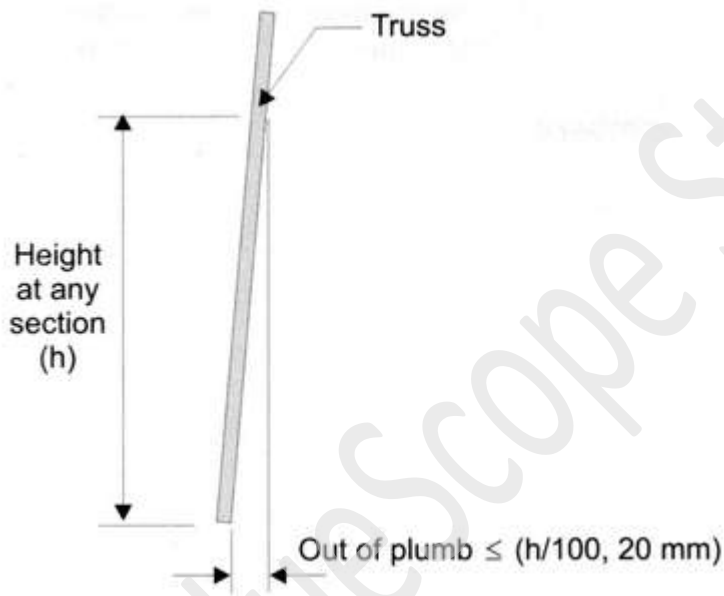

Figure 4.3 Plumb

5.0 Truss identification

A summary of the description of trusses is shown in Figures 5.1 and 5.2, and a glossary of terms is indicated below.

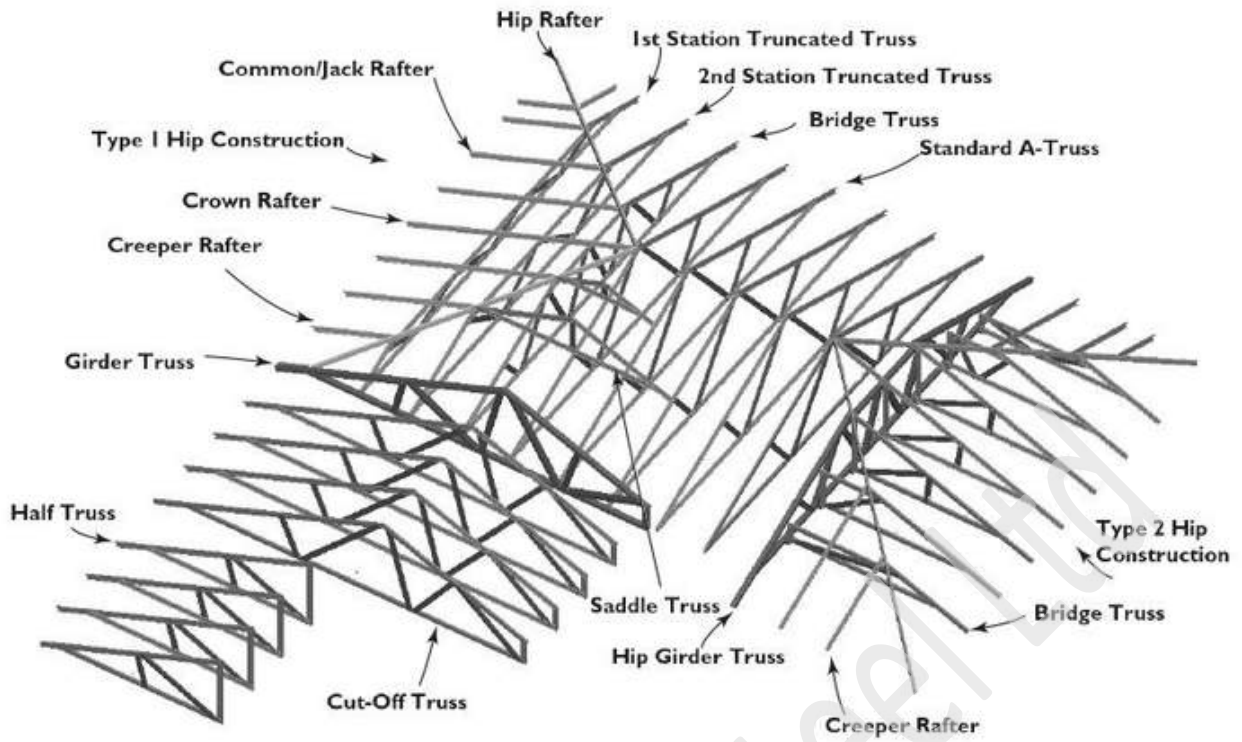

Figure 5.1 Typical Roof truss components

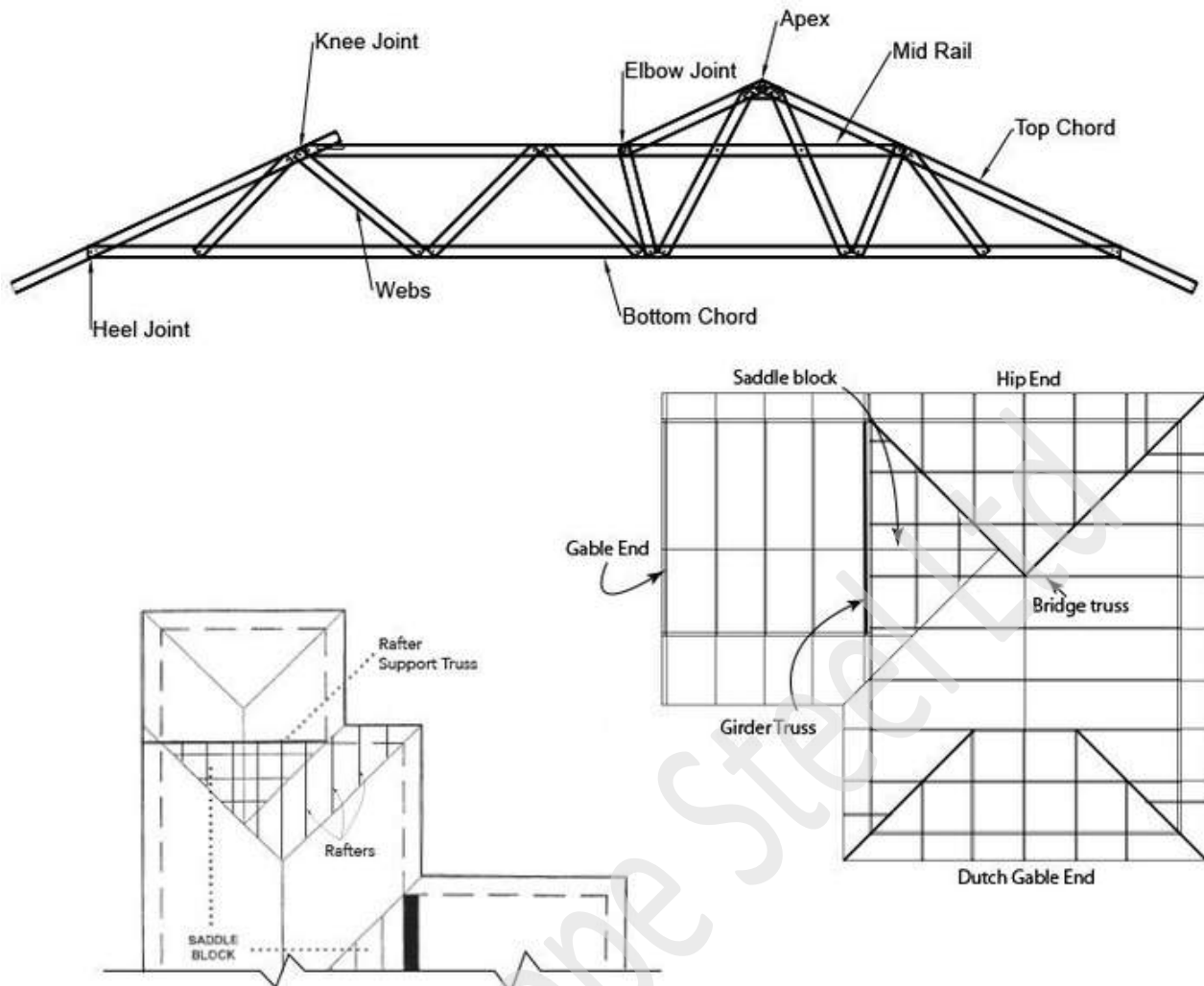

Figure 5.2 Roof truss components (plan view)

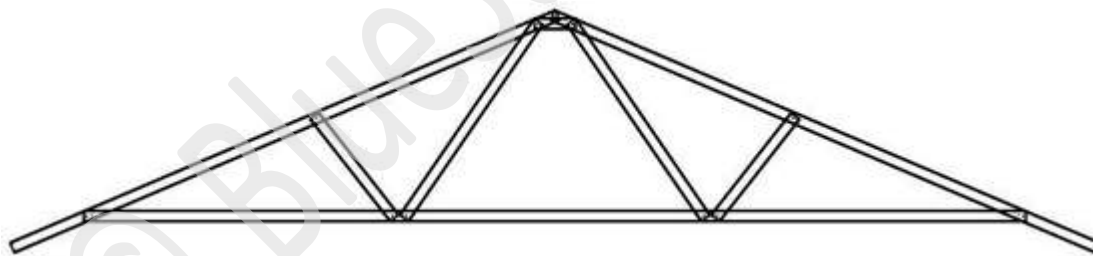

Figure 5.3 Standard 'A' Truss/ Dutch Gable Truss

5.1) Standard A-Truss: An A-framed truss supported at both ends by load bearing walls. It forms the main gable roof block (Refer to Figure 5.3).

5.2) Dutch Gable Truss: A Dutch Gable truss is formed when whaling plates are fixed to the flat face of an A-truss to support common rafters.

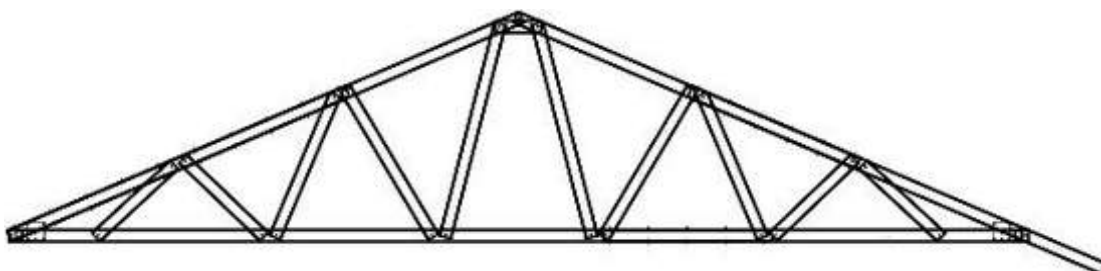

Figure 5.4 Girder Truss

5.3) Girder Truss: A structural truss at the end of a roof block that supports incoming trusses from an adjoining block (bridge trusses). A girder truss may replace a supporting wall or beam. It can be used to support bridge trusses and may be used in lieu of an internal load bearing wall or beam (Refer to **Figure 5.4**). A girder truss may be either a single truss or a pair of trusses installed lip to lip.

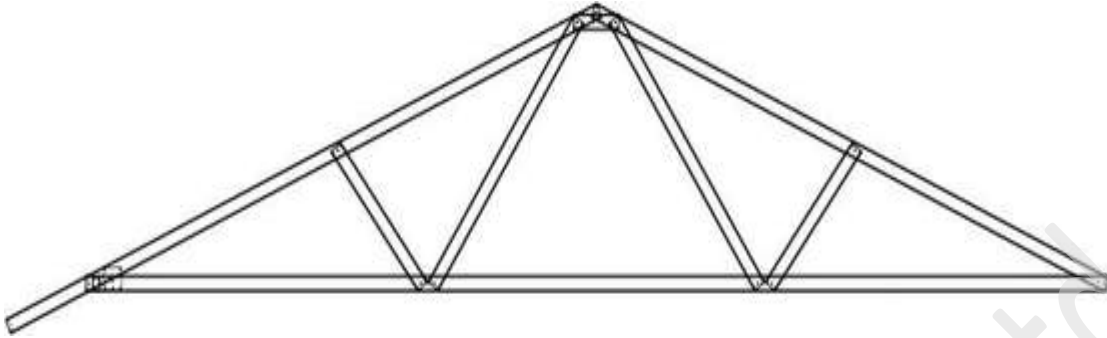

Figure 5.5 Bridge Truss

5.4) Bridge Truss: This truss type can be either a standard truss or a truncated truss with the overhang removed at the heel. A TBJ45 bridge bracket is fitted to connect the truss to a beam or girder truss (Refer to **Figure 5.5**).

5.5) Creeper Support Truss: A truss which has an angle lintel fixed to the flat face of the bottom chord. It is used to support the ends of the creeper rafters when a roof incorporates an internal hip.

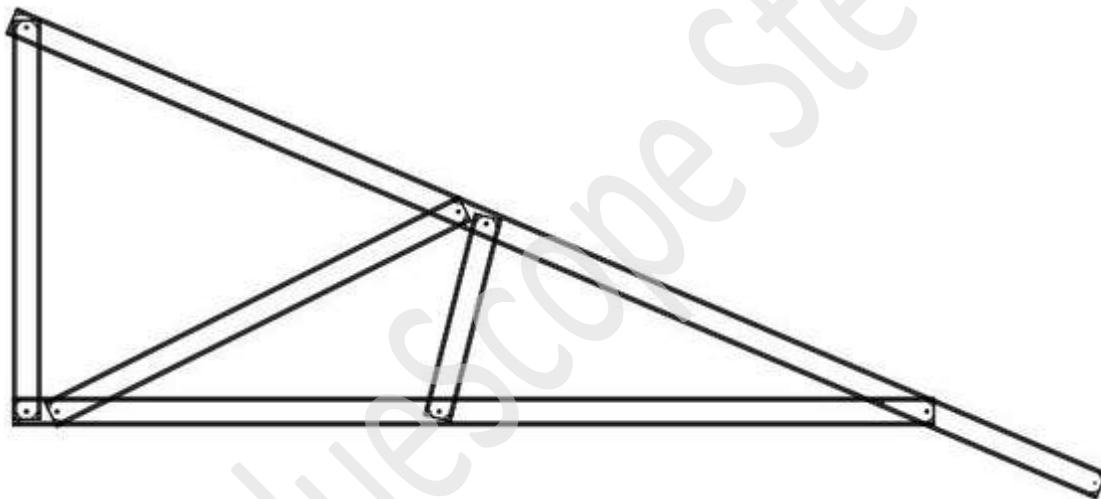

Figure 5.6 Half Truss

5.6) Half Truss: A triangular shaped truss with the end web fixed vertically and at 90 degrees to the bottom chord. It is commonly used to form verandah roofs on the lower floor of two storey homes (Refer to **Figure 5.6**).

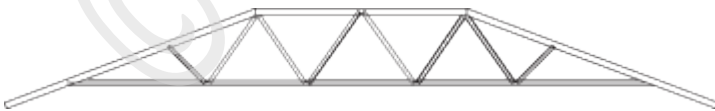

Figure 5.7 Truncated Truss/Hip Girder Truss

5.7) Truncated Truss: A truss of varying depth with a horizontal top chord. Truncated trusses are usually used to form a hip end (Refer to **Figure 5.7**).

5.8) First Station Truncated Truss: The first truncated truss in from hip end wall.

5.9) Second Station Truncated Truss: The second truncated truss from hip end wall.

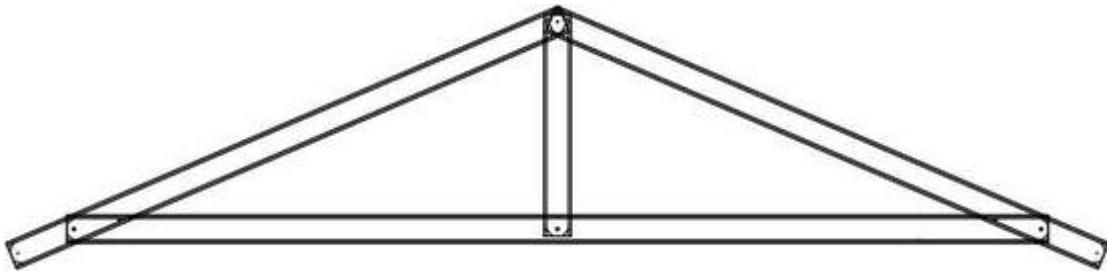

Figure 5.8 Saddle Truss

5.10) Saddle Truss: A-truss with the top chords cut at the heel to form a foot cut. It is used to form a valley line when two roof planes intersect. Saddle trusses are supported by trusses or rafters below (Refer to **Figure 5.8**).

5.11) Truncated Saddle Truss: A saddle truss with a horizontal top chord used to form a valley line when two roof planes intersect with a hip end close to the valley. It supports hip end rafters.

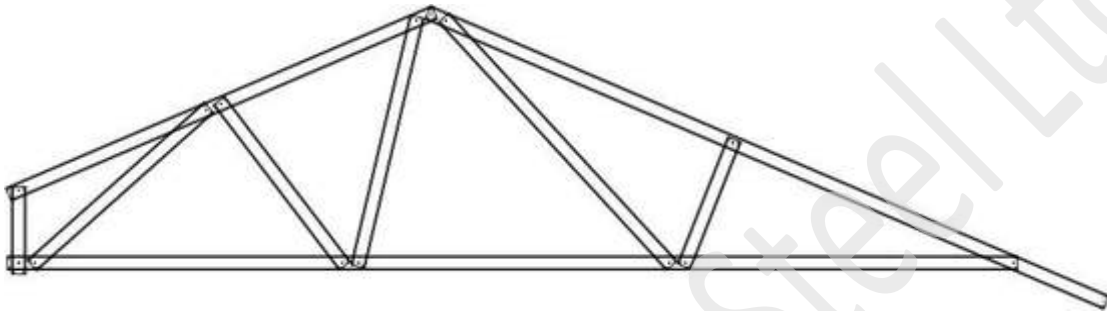

Figure 5.9 Cut-off truss

5.12) Cut off truss: A standard truss with a cut to one or both ends.

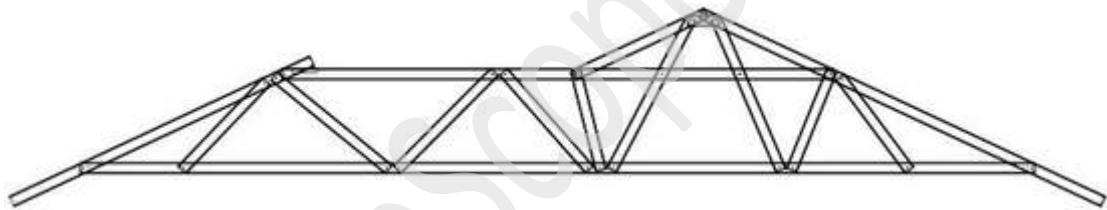

Figure 5.10 Peak truss

5.1.13) Peak truss: A truss that helps to create four or more roof faces. The Peak truss may support one or more hip and valley lines.

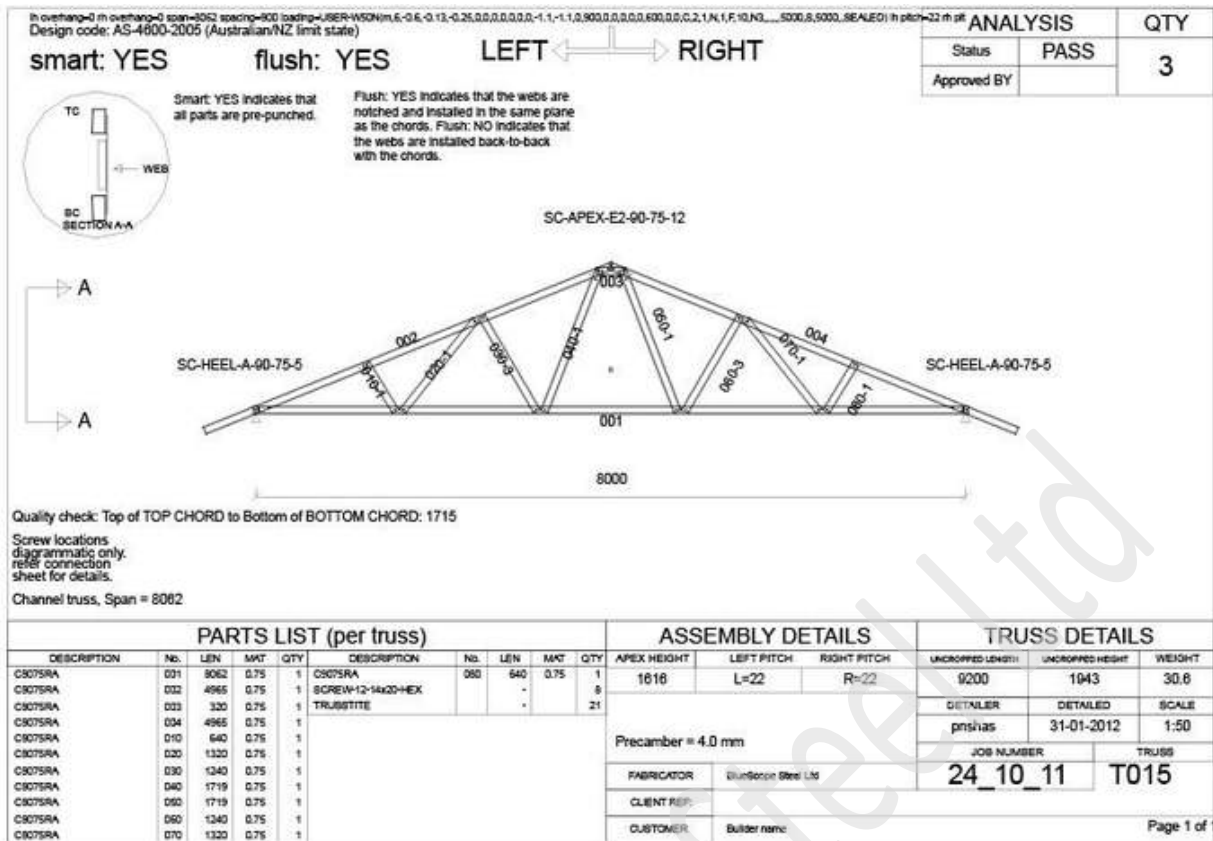

Figure 5.14: A typical truss assembly sheet as produced by ENDUROCAD® SOFTWARE.

6.0 Truss Assembly

6.1 ENDUROTRUSS® Framing System marking and branding

All ENDUROTRUSS® Framing System parts are coded with information to assist erectors in the assembly process. This matches the part information shown on the assembly drawings.

All ENDUROTRUSS® Framing System parts are coded with the following:

- Part Number
- Truss Number
- Job Name/Number
- Part Length
- Part Usage.

They also contain the rollformer number and date of manufacturing for traceability purposes.

With this information, erectors can identify what the part is and where it is intended to be used in the structure. The illustration below shows how the coding works. The sections are marked when produced in accordance with **Section 6.1** of this manual.

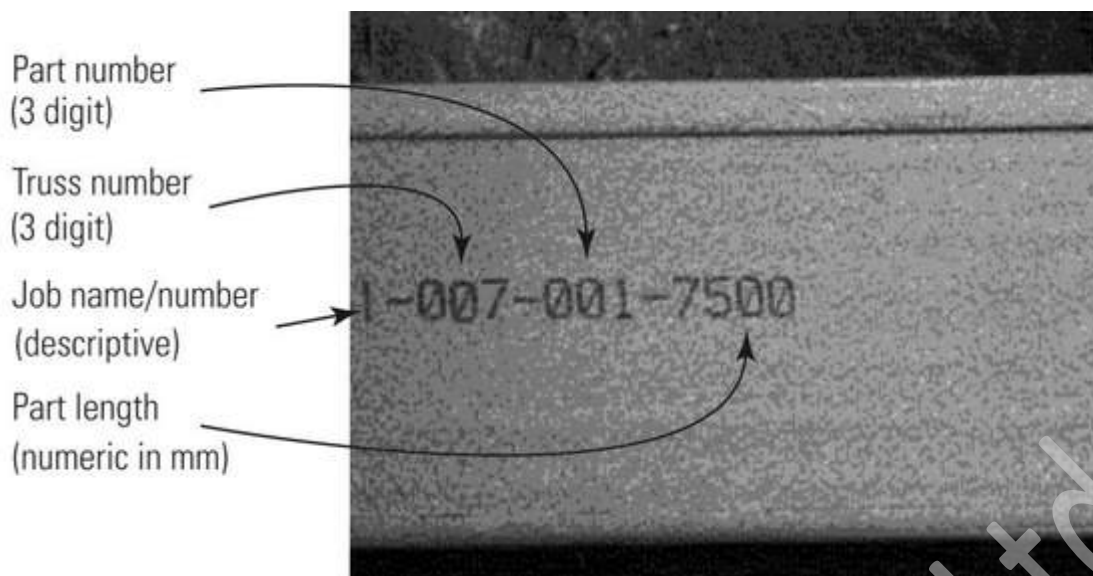

Figure 6.1 Marking and branding

So the above example illustrates that this member is for Job Number 1, it is part of truss number 7 (as numbered by the software in the construction drawings), it is part number 1 and is 7500mm in length.

6.2 Chord to chord connection identification

Connections are identified on the truss assembly sheet by a connection code. The connection detail is displayed on an ENDUROCADD® software generated connection sheet showing all the connections used in the specific job. The chord to chord connection code is displayed next to the connection on the assembly sheet. (Refer to Figure 6.2.)

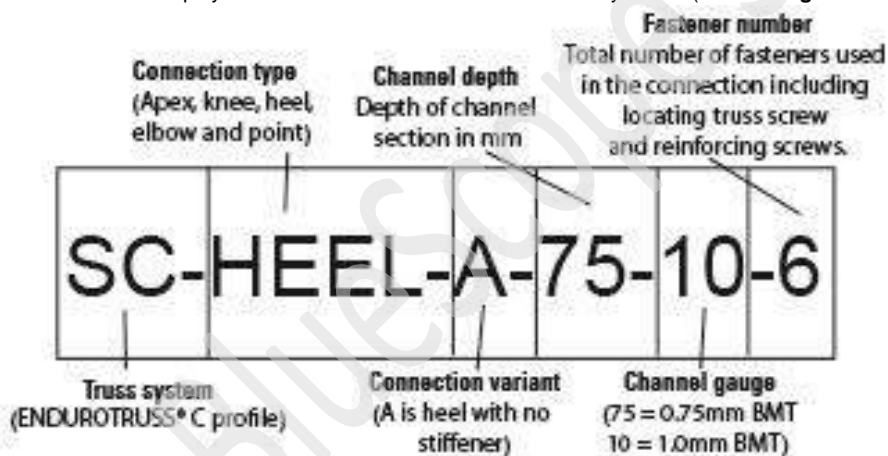

Figure 6.2 Connection identification

The connection code is explained using the above example

Example SC-HEEL-A-75A-75-10-6

Field 1 The truss system- in this case ENDUROTRUSS® C profile

Field 2 The connection type - Options:

APEX, KNEE, HEEL, ELBOW and CHORD POINT

Field 3 The Connection- Type A is a heel for a tiled and sheet roof

Field 4 The depth of the channel section

Field 5 The gauge of the channel - 10 is 1.0 BMT and 75 is 0.75 BMT

Field 6 The number of fasteners used in the connection. Includes any locating truss screw, reinforcing screws or stiffener connection fasteners.

6.3 Fasteners

Truss members are joined together with two types of fasteners.

A locating Trusstite truss screw which is a hex-head fasteners with a trilobular thread for fixing through pre-punched holes and a #12-14x20 hex-head self drilling reinforcing fasteners. Fasteners should always be supplied by the manufacturer of the trusses and

be in accordance with the specifications described in the ENDUROFRAME® Design Manual for mechanical and coating properties. All fasteners should have a minimum Class 3 coating. The specifications of the locating Trusstite truss screw may be either:

- #17-15x15 hex. head or
- 5/16"-12x17 hex. head screw.

The use of the correct fasteners in the quantities shown in the truss fabrication drawings are essential to ensure the design capacity of the trusses are achieved.

The following illustrations show the typical steps for assembly of a truss. In this example the webs are linked for ease of locating the parts.

6.4 ENDUROTRUSS® Framing System assembly

The following illustrations show the typical steps for assembly of a truss.



Step 1: Part Identification

Unpack the trusses and sort into truss lots using the branding as a guide. Identify the chords and webs from the branding information on the parts.



Step 2: Truss Layout & Chord Assembly

Identify the chords and lay them down on a level surface or assembly table and align as per assembly drawing. The chords should be pre-notched allowing parts to overlap as shown. Pre-punched holes are provided for locating truss screw to connect the chords at the apex, heel and knee.

Note: branding is on the side flange which will be on the inside of the truss chords which can aid in laying out.

Step 3: Align holes and install a locating truss screw - fix at heels

When carrying out the primary assembly of the heel align notch holes as shown and install a locating truss screw in holes.



Step 4: Fix at apex or knee and install a locating truss screw

Align notch holes as shown and install a locating truss screw in holes.



Step 5: Web Installation

Separate linked webs by cutting or snapping pieces apart. If webs are joined they will be attached in the order required for assembly (Left to right). Snip or snap the webs apart and position each one over the truss chords near their final location. Where flush truss is being used (as in this example), the branding on the webs will face towards the top of the truss and toes of the channel will face down. For a non-flush or back to back truss the flanges of the webs face up and no notches are provided at the web ends.



Step 6: Align holes and fix connection with a locating truss screw

Using part identifier numbers layout the webs in accordance with the Assembly Sheet. Line up the 6mm locating holes on the ends of the webs with the appropriate holes on the truss chords. If a "flush" truss is being installed the flanges of the web are to face downwards in line with the truss chords. Install a locating truss screw into the aligned holes ensuring that the screw is driven firmly home and does not strip. Should the locating truss screw strip, reduce the driver torque and place a 12-24x20 self drilling screw 20mm minimum from the locating truss screw.



Finished knee web connection (unreinforced)



Finished connection (reinforced)



Step 7: Overall Quality Check Before inserting any stiffeners or reinforcing screws check the overall dimensions of the truss against the Assembly Sheet.

For a complex shape truss, lay it on top of a previously assembled one and check they are the same.

6.4 ENDUROTRUSS® splicing

Large span trusses may be too large to economically transport and components may be too long to rollform and handle through the manufacturing workshop. The detailing software allows the Trained Software User to set a maximum component length. Where this length is exceeded the software will create a splice to subdivide the component. The splice will be located between truss panel points and close to the centre of the panel.

The two bottom chord members connect using the standard notched end as shown in **Figure 6.3**.



Figure 6.3 Bottom Chord connection at splice

After the chords are connected, a boxing piece is placed over the chords and fixed with 12-14x20 self drilling screws following the connection details in **Figure 6.4**.

Boxing member is Ribbed Channel of the same gauge and depth as the truss.

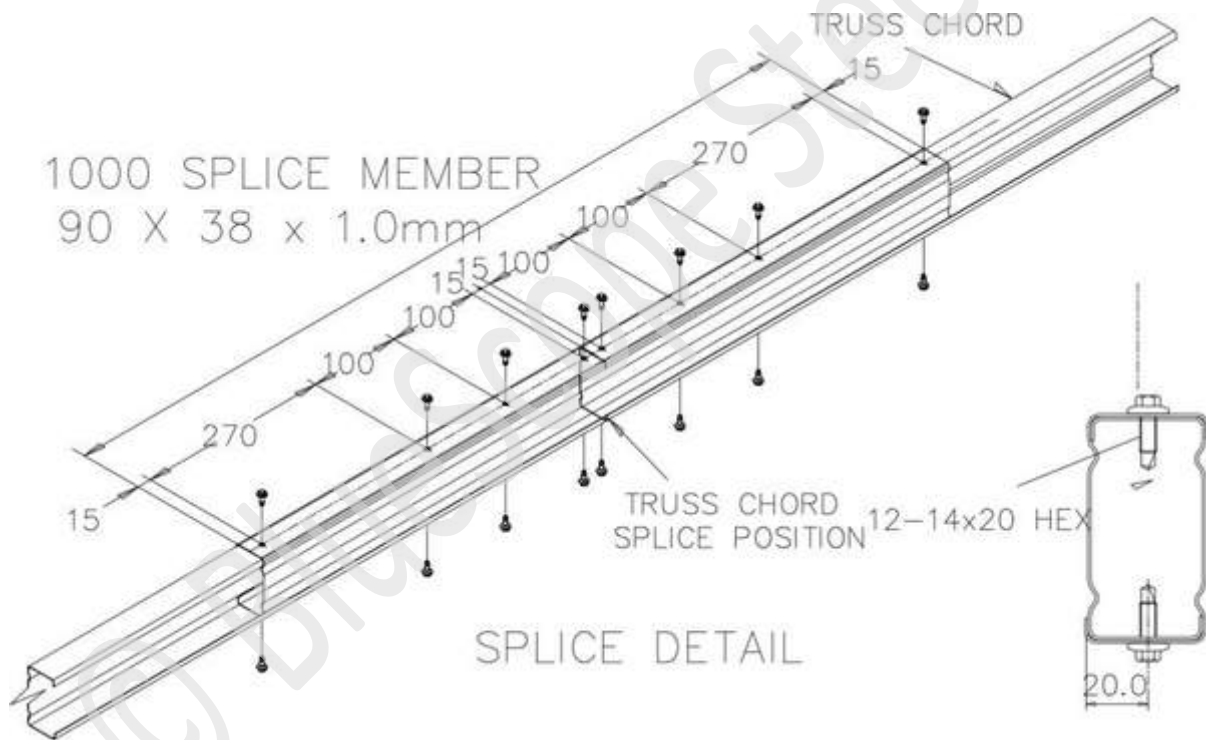

Figure 6.4. ENDUROTRUSS® Splice Details

6.4.1 Splicing of Boxed Chords

Splicing of boxed chords is to be in accordance with the following diagram.

Note: The splice points for the individual members must be separated by a minimum of 600mm

A piece of U section stiffener the same gauge as the chords is to be housed over the spliced sections and extend 250mm either side and fixed with the recommended number of M6-1P x 18mm smooth top Tek screws.

Where the splice is separated by more than 1500mm it is more practical to apply a 500mm length of U section stiffener to each join and fixed with 6 x M6-1P x 18mm smooth top Tek screws to each end.

6.4.2 Splicing Boxed Chords

To maintain a minimum 600mm separation on the individual splice locations, the splice is to be placed at a minimum of 300mm off centre of the required cut point. The chord boxing sections are then to be installed reversed end-on-end to offset the splice location.

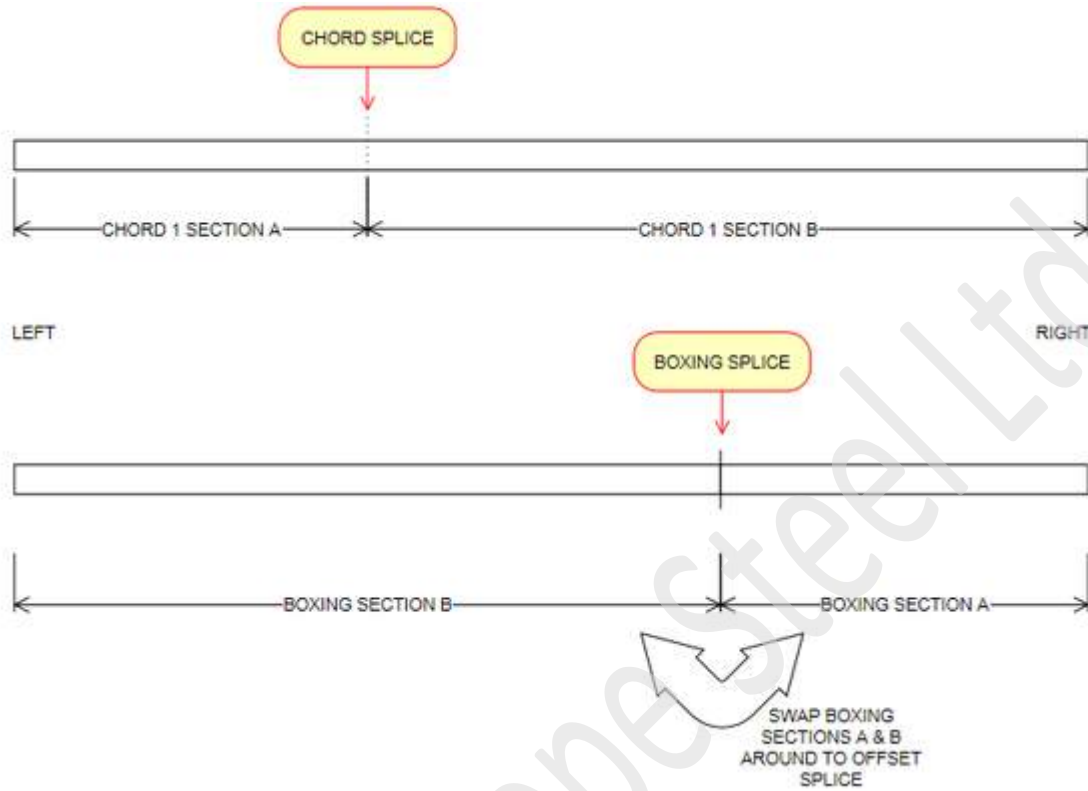

6.5 ENDUROTRUSS® Framing System stiffening and re-inforcement

Refer to the ENDUROCAD® software generated connection drawing and the assembly drawings to identify reinforcing screws and stiffeners required to complete truss assembly. Primary fixing screws are self-locating Trusstite screws fastened through pre-punched holes, while reinforcing screws are #12-14x20 hex-head self-drilling fasteners, without washers. Stiffening screws should be installed a minimum of 21mm from each other and the locating screw and a minimum distance of 10mm from the edge and 17mm from the end.

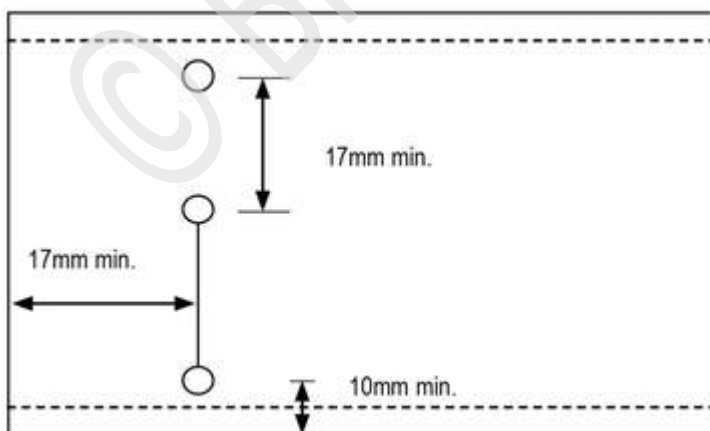

Figure 6.5 Stiffening screw distances

From the appropriate connection drawing, identify the location and type of stiffener and/or the screws required. Install as shown on the drawing. Different stiffeners are specified for various loading and geometry.

The following posters can be used to summarise the location of screws in connections. They can be printed in A0 and laminated and

placed next to locations where trusses are to be assembled.



6.5.1 Web stiffening

Identify webs requiring reinforcing screws by referring to the code printed on the part or the truss assembly drawing. For example 030-3 refers to three fasteners required on each end of web 030. For larger trusses and flush, an additional screw may be placed in unreinforced webs to strengthen the trusses in the horizontal plane during handling, although they are not required for structural purposes. The position of the additional screw is as shown in step 6 of **Section 6.3**.

6.5.2 Apex stiffening

Identify the number and location of reinforcing screws required for chord to apex plate connection by referring to the connection drawing for the apex type. The range of apex stiffening options are shown in **Table 3**.

For example SC-APEX-E1-75-10-5 means to install one locating truss screw and four number #12-14x20 hex head screws.

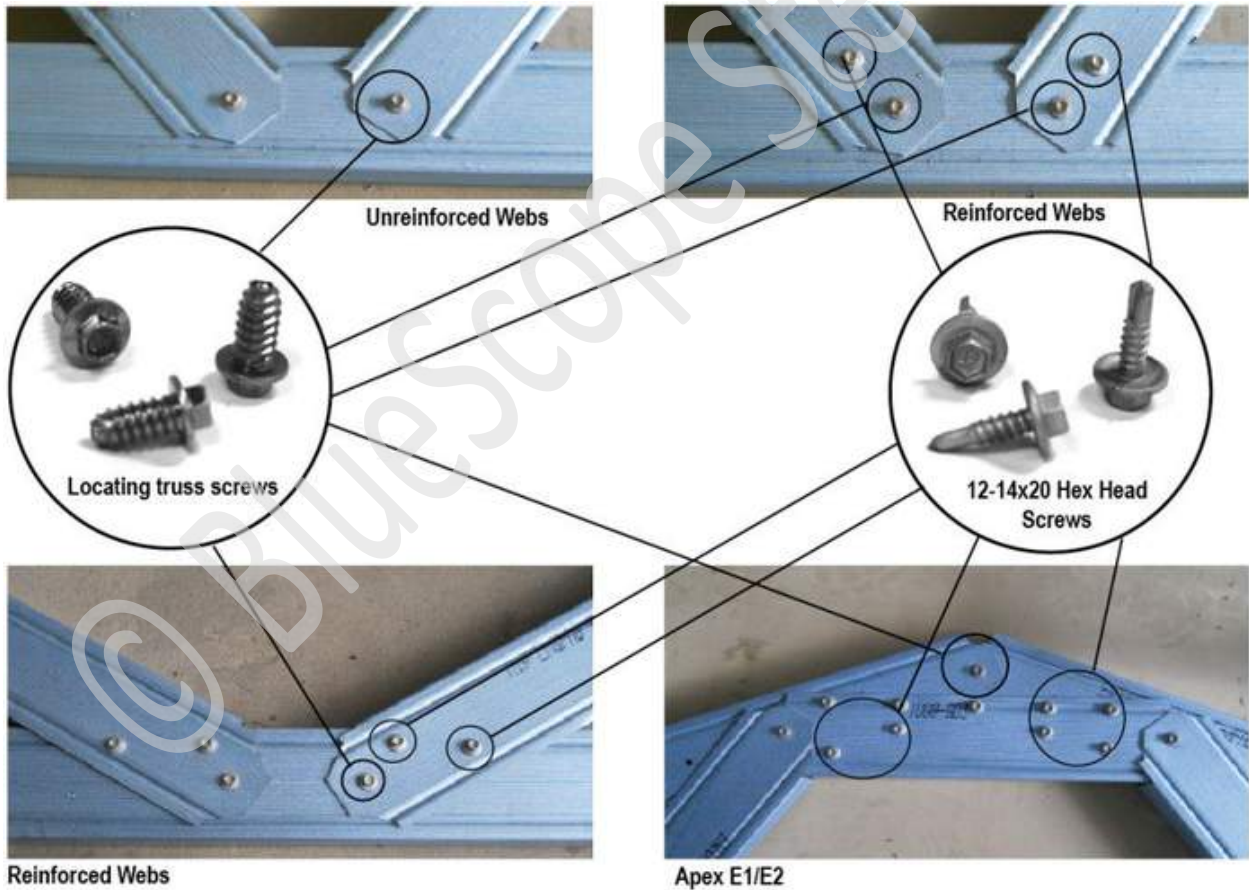
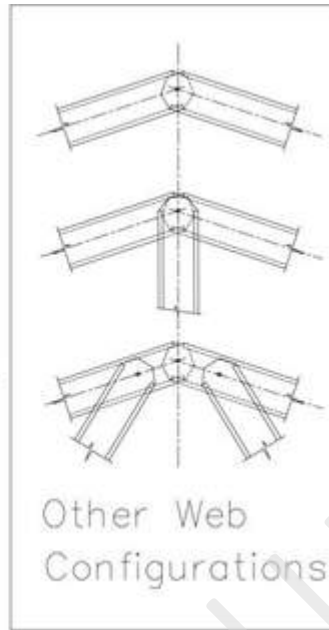
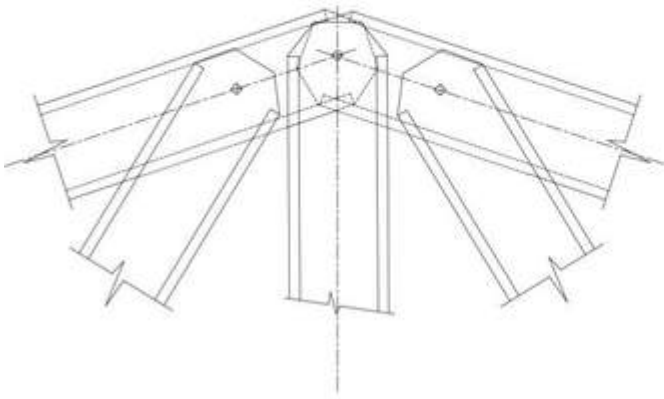

Table 3 Apex types

Apex A



No stiffeners or plates and a single Trusstite connection

Apex E1

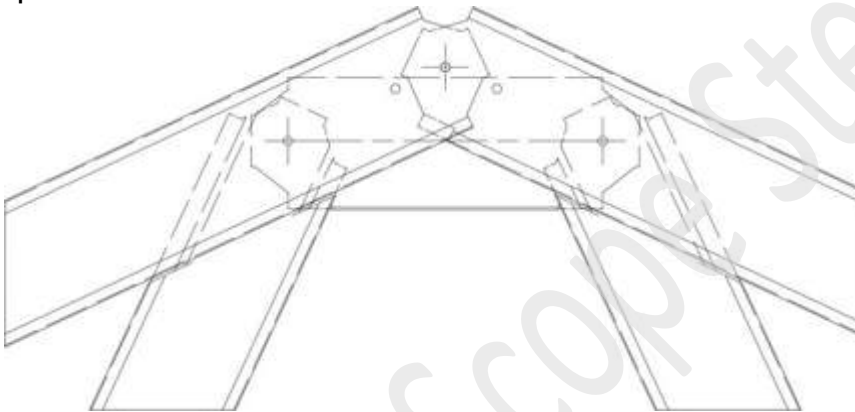

Notched C stiffener plate across apex with webs connected to top chord

Apex HS

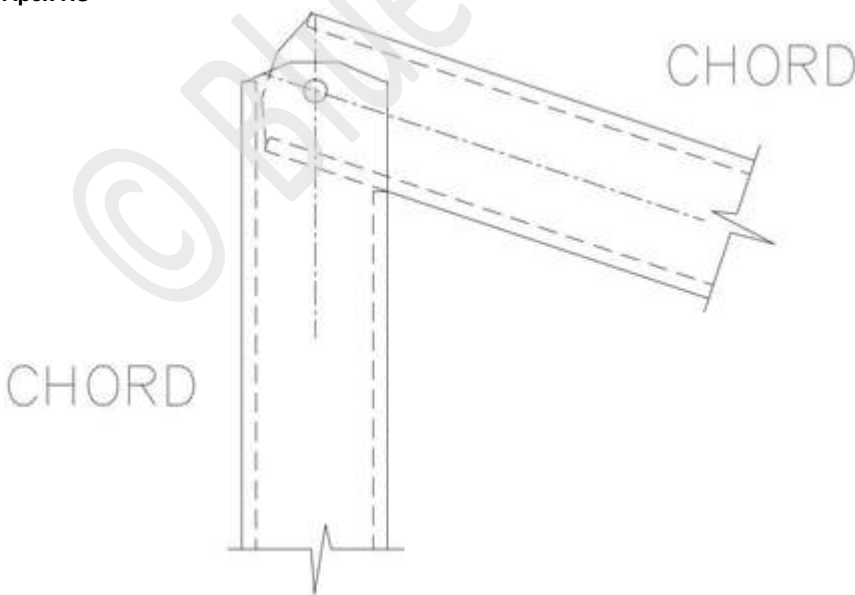

Back-to-back chord sections

Apex F

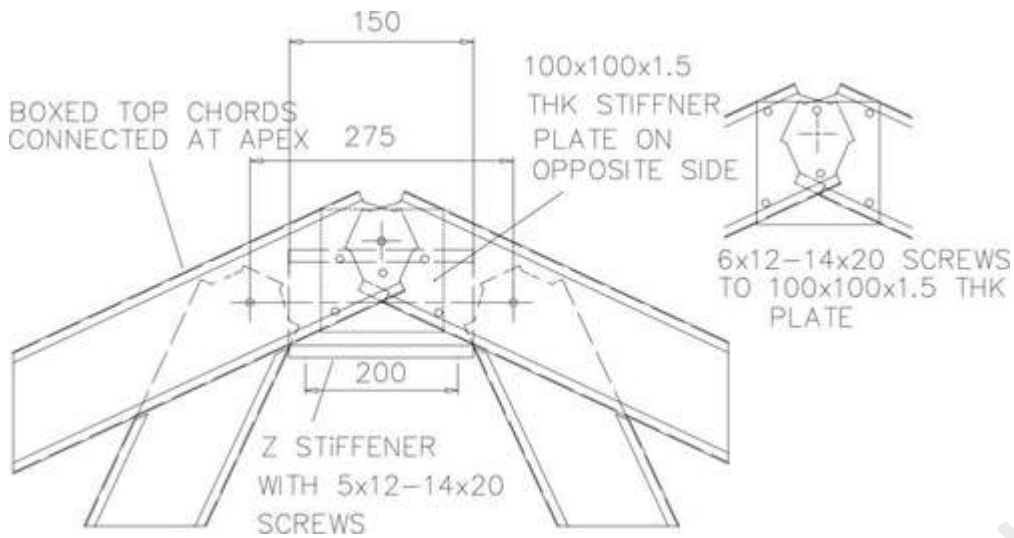

200mm long Z10015 section over 125 x 125mm x 1.5mm stiffener for 90mm section or 100mm x 100mm x 1.5mm stiffener for 75mm section

Apex C

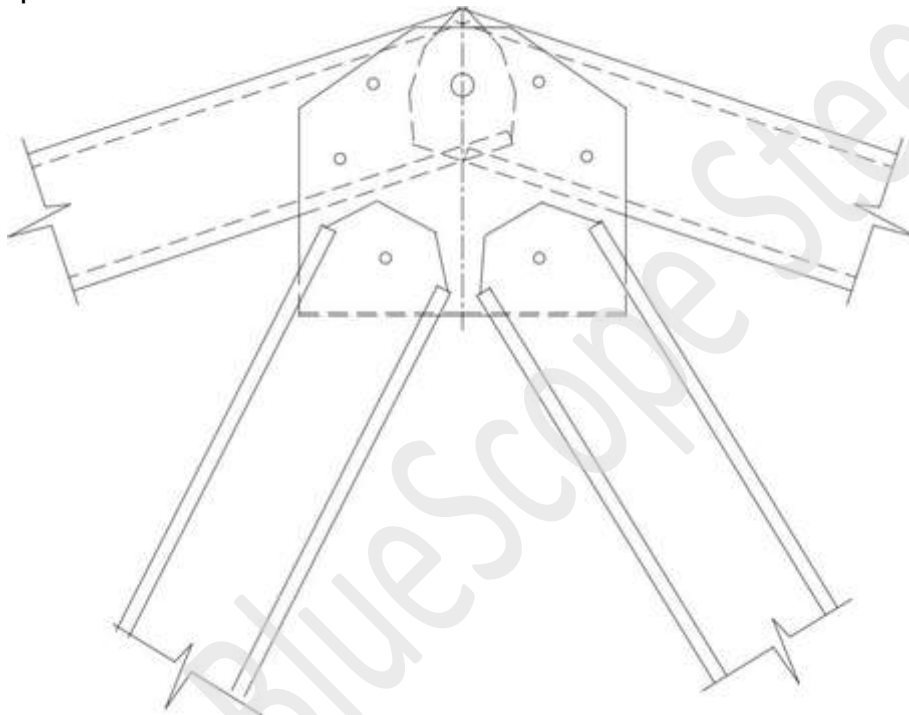

Standard apex plate connection

The fabrication drawing for the Apex C connection plate is located at this link - [Smart Truss Apex Plate P11350-2.pdf](#).

Apex E2

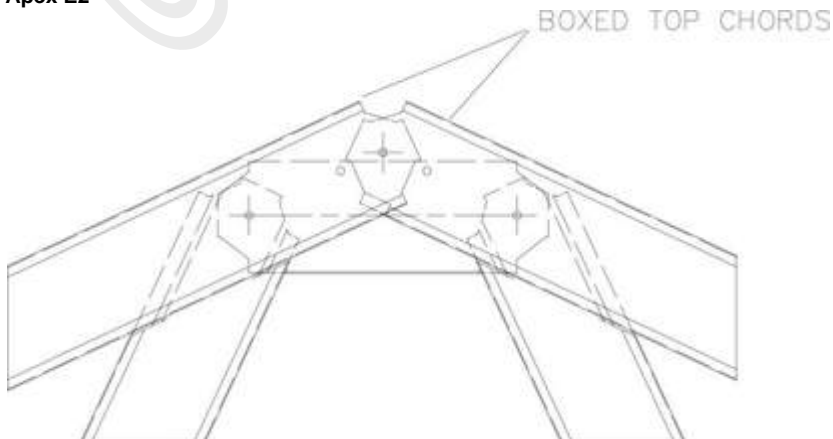

Notched C section with boxed top chords

Apex HSF

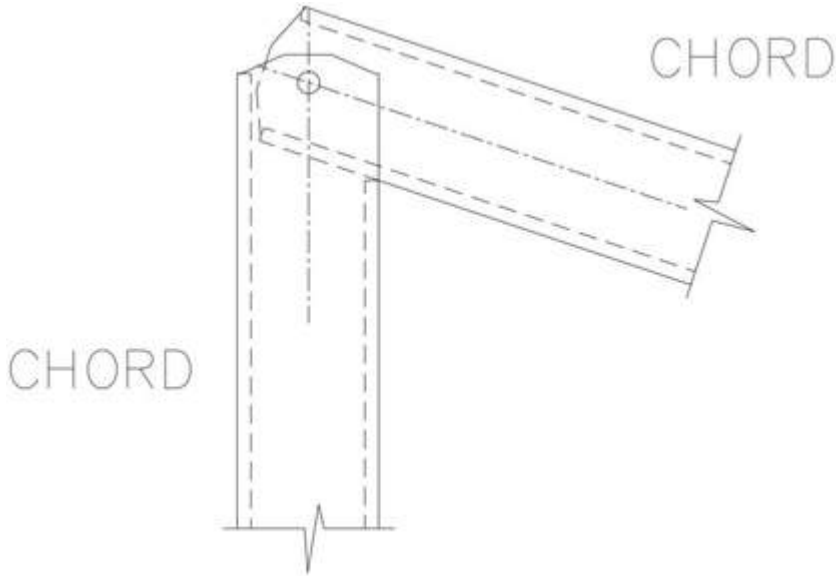

Flush chord connection

6.5.3 Heel Stiffening

A range of heel stiffeners are available to enhance truss capacities and are changed depending on whether a truss or sheet roof is being used. From the appropriate connection drawing, identify the location and type of stiffener and/or the screws required. Install as shown on the drawing.

Heel A

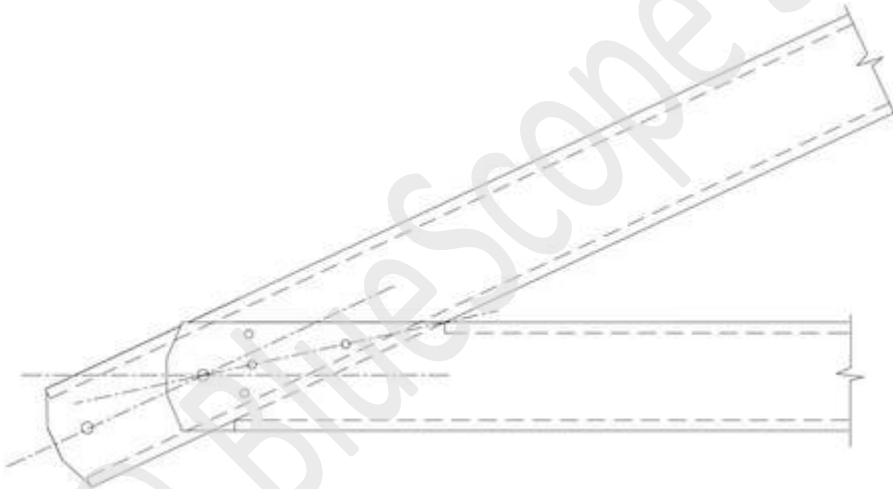

Heel Connection with no stiffener or brackets. Used for lower span tile roof and low wind areas sheet roof

Heel B

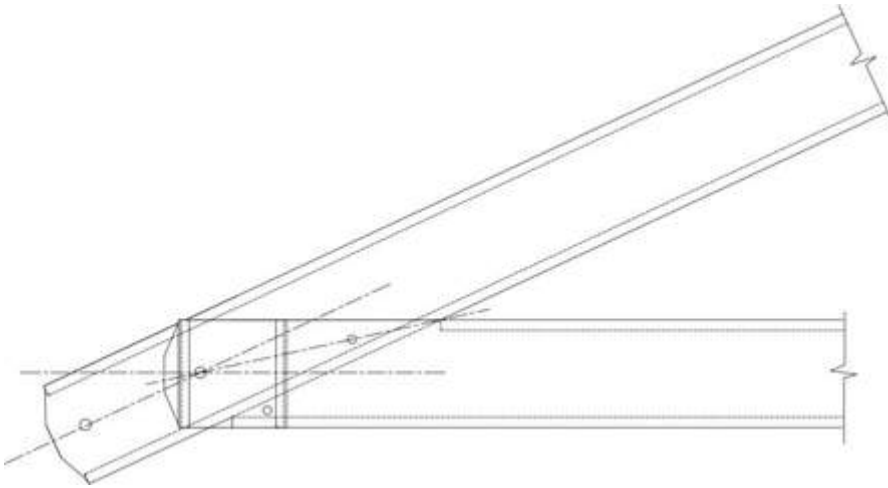

Heel Connection with vertical channel stiffener. Stiffener increases bearing capacity of connection

Heel E1

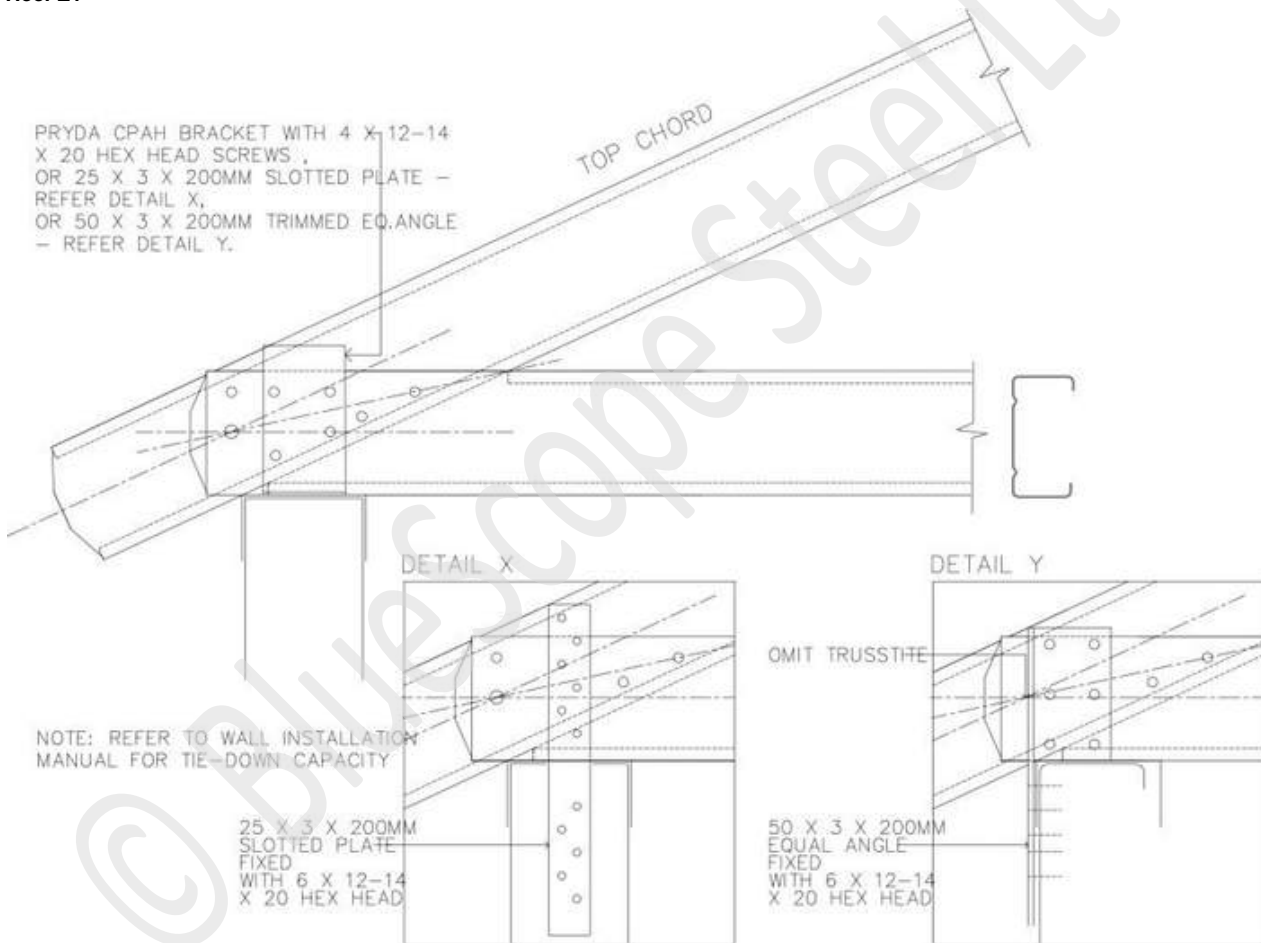

Heel strengthened with CPAH bracket, 25 x 3 x 200mm plate tie or 50 x 3 x 200mm equal angle tie

Heel E2

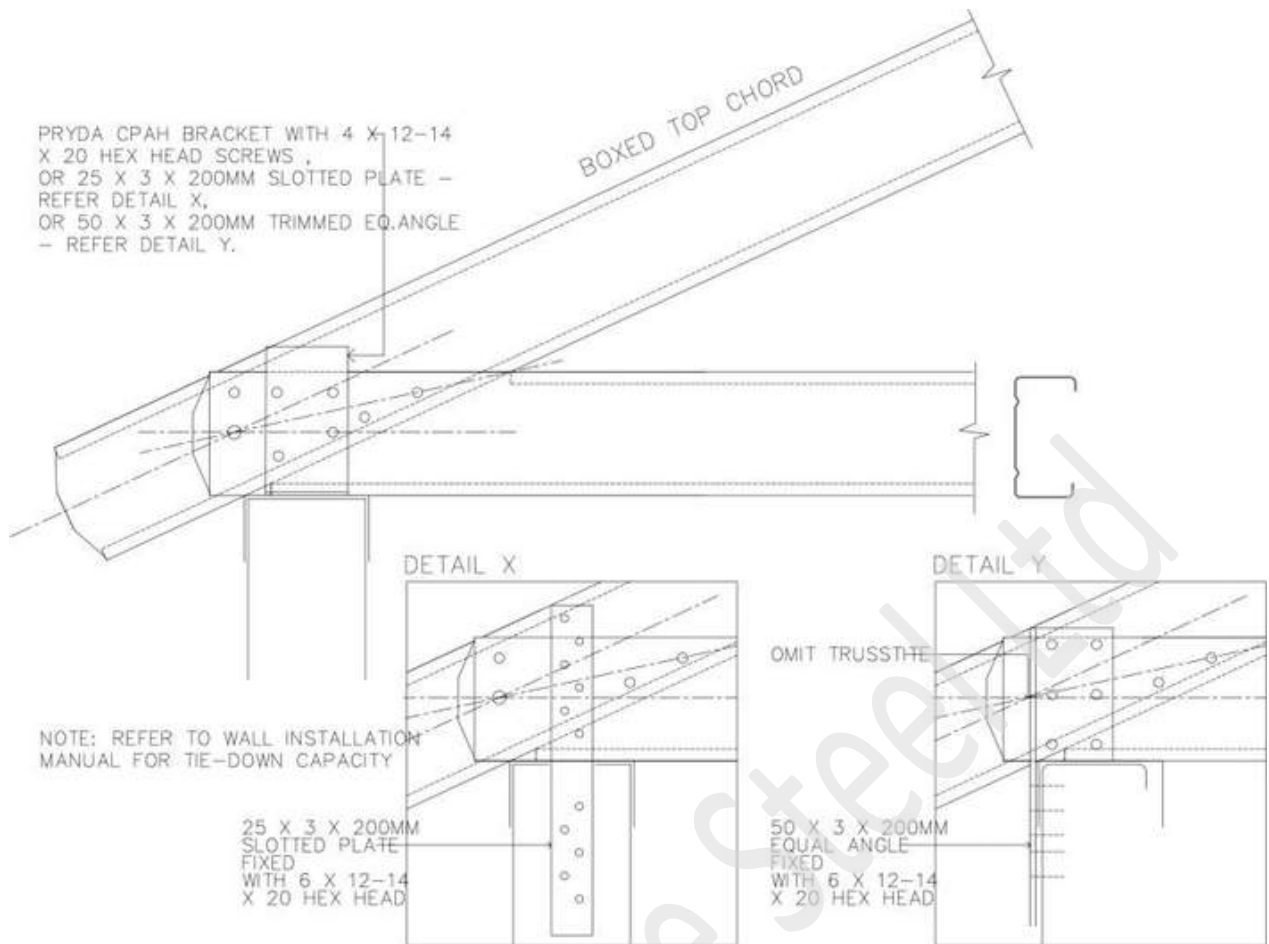

Heel strengthened with CPAH bracket, 25 x 3 x 200mm plate tie or 50 x 50 x 3 x 200mm equal angle tie, with a boxed top chord.

Heel F1

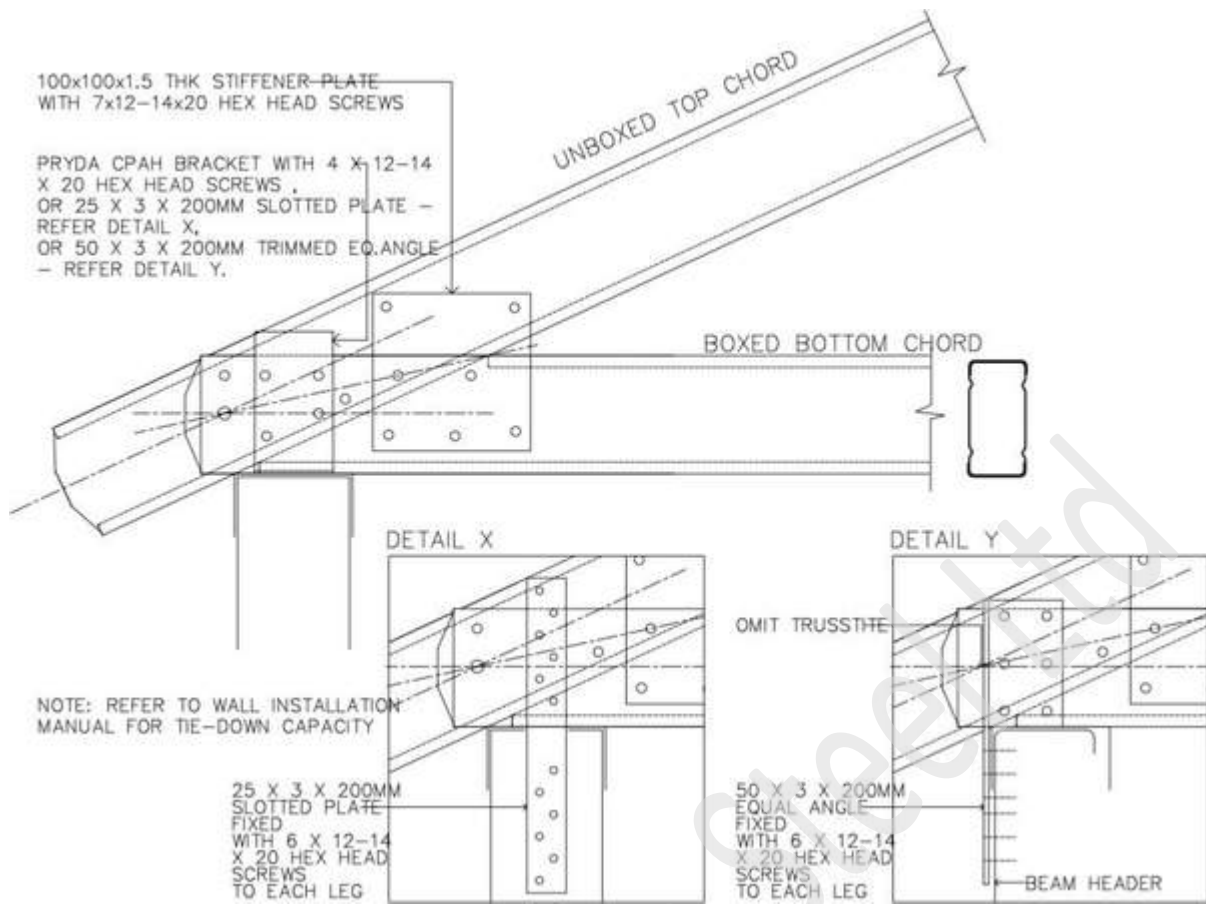

Heel strengthened with CPAH bracket, 25 x 3 x 200mm plate tie or 50 x 50 x 3 x 200mm equal angle tie and 100x100 x1.5mm plate for 75mm truss and 125x125x1.5mm for 90mm truss

Heel F2

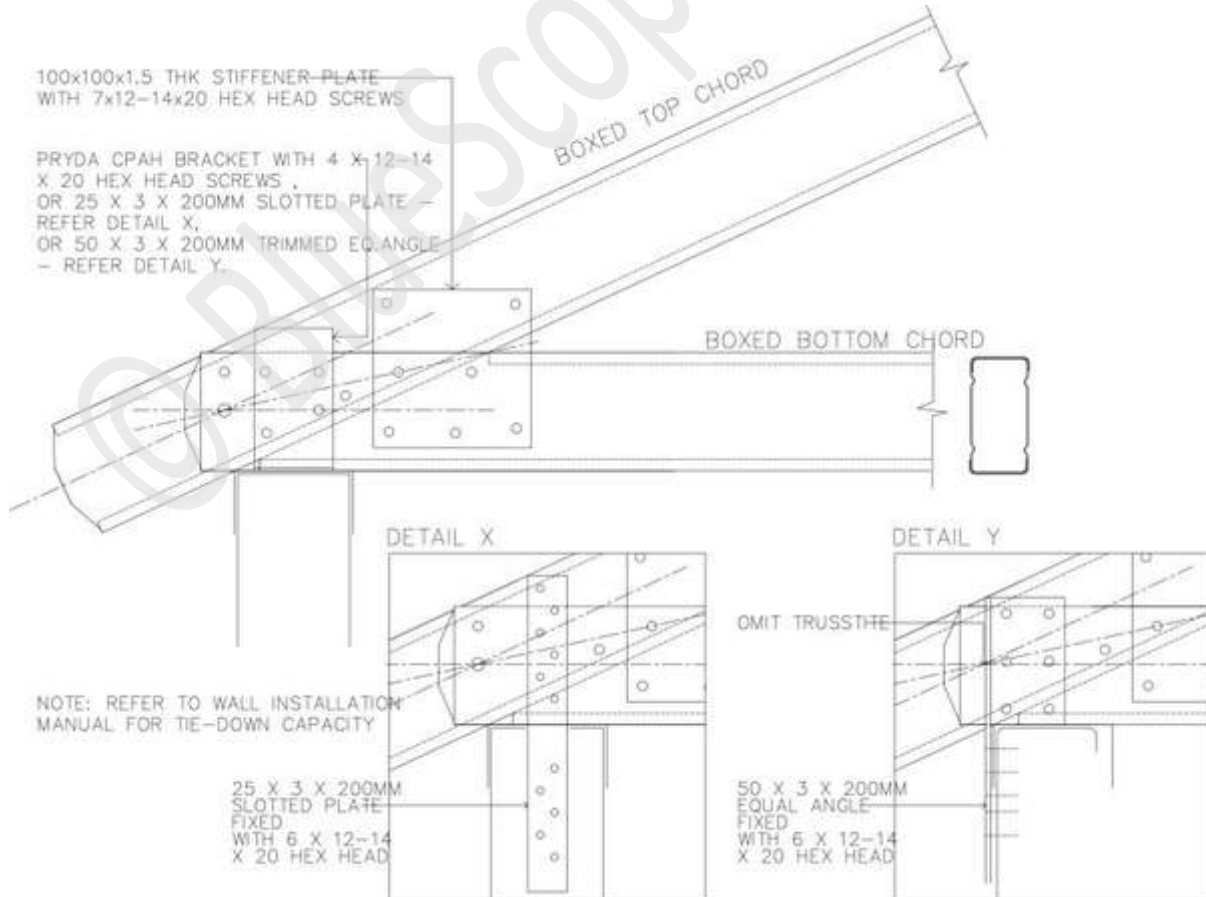

Heel strengthened with CPAH bracket, 25 x 3 x 200mm plate tie or 50 x 50 x 3 x 200mm equal angle tie, and 1.5mm plate with a boxed top chord 100 x 100 x 1.5mm plate for 75mm truss and 125 x 125 x 1.5mm for 90mm truss

Heel G

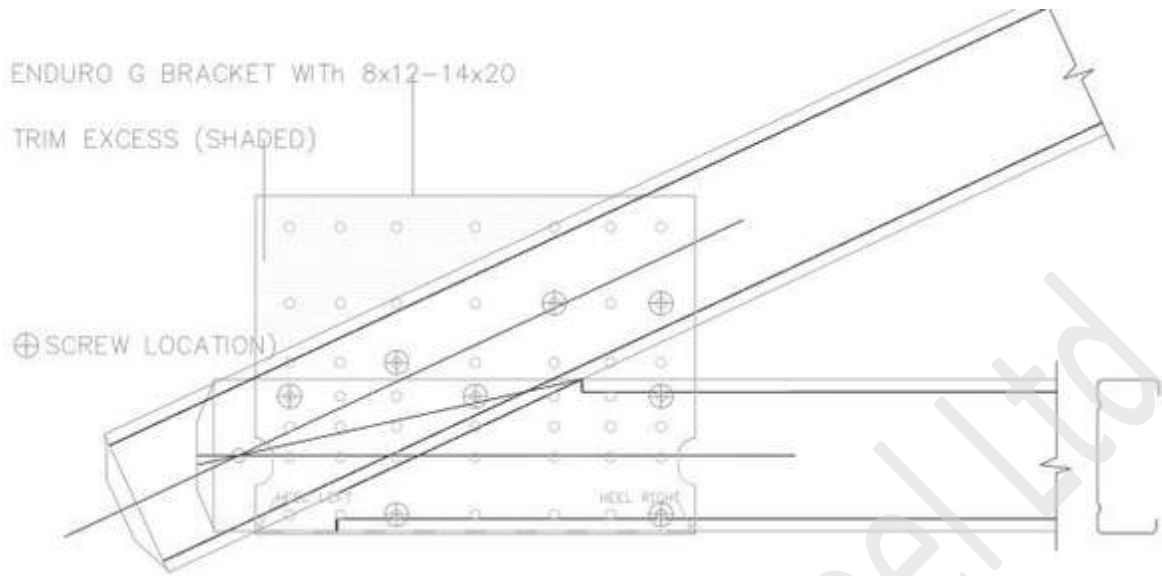

1 TRUSSTITE + 8X12-14X20 HEX SCREWS

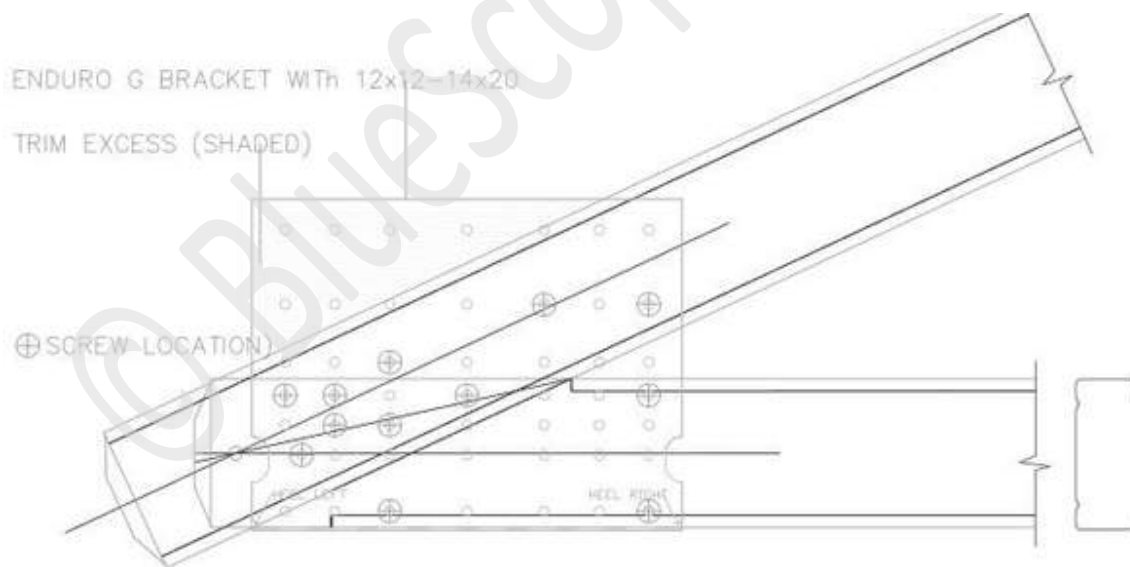

1 TRUSSTITE + 12X12-14X20 HEX SCREWS

Heel strengthened with Heel-G bracket (200x35x1.5 thk)

Heel HS

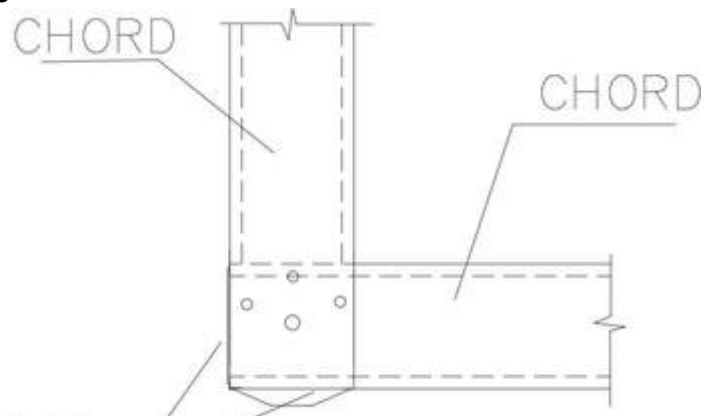

BEND 90 DEGREES ON ASSEMBLY

Half Truss Heel where the vertical member is designed as a Chord

Heel HS-F

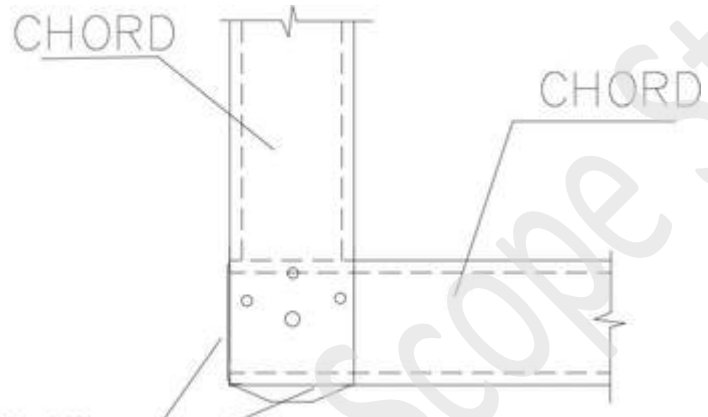

BEND 90 DEGREES ON ASSEMBLY

Half truss Heel where the end member has chord attributes and is flush

Heel HS-5-A

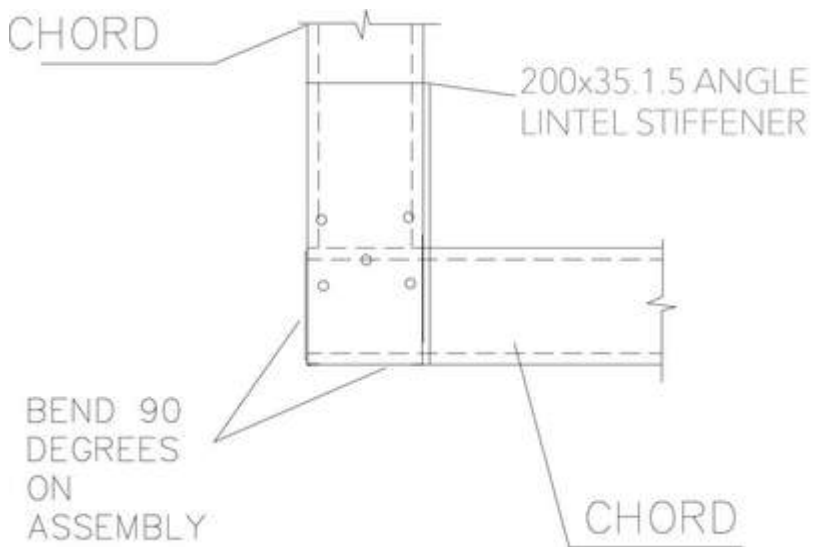

Stiffened version of the HS-F connection using a 200x35x1.5mm lintel section

6.5.4 Knee Stiffening

From the appropriate connection drawing, identify the location and type of stiffener and/or the screws required. Install as shown on the drawing.

The 35 x 35 x 200 x 1.0mm angle stiffener is provided for high compression knee connections (Knee Type D) or a 125mm x 125mm x 1.5mm plate (Knee Type E).

Summary of Knee Stiffeners is below.

Knee A

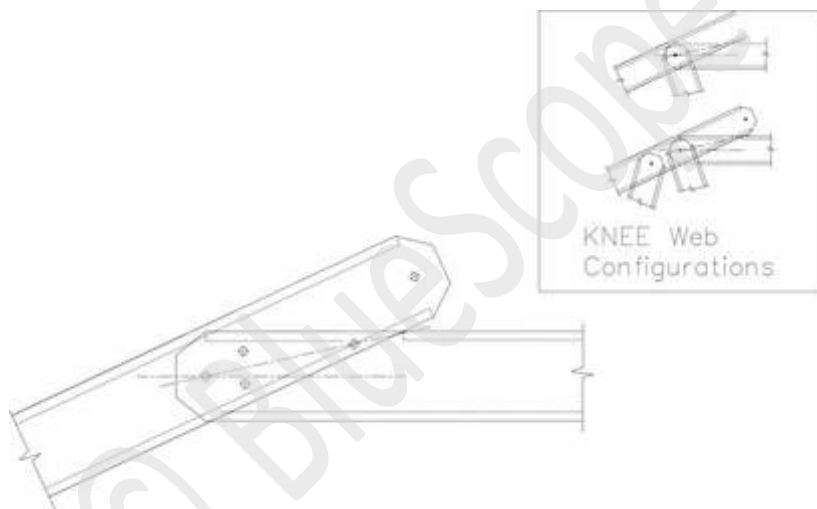

Unreinforced knee

Knee C

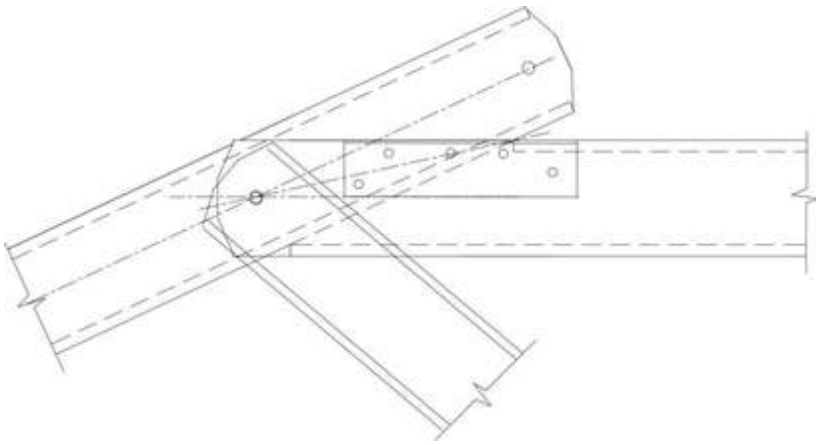

Horizontal 35 x 35 x 1.0mm angle stiffener, 200mm long

Knee E

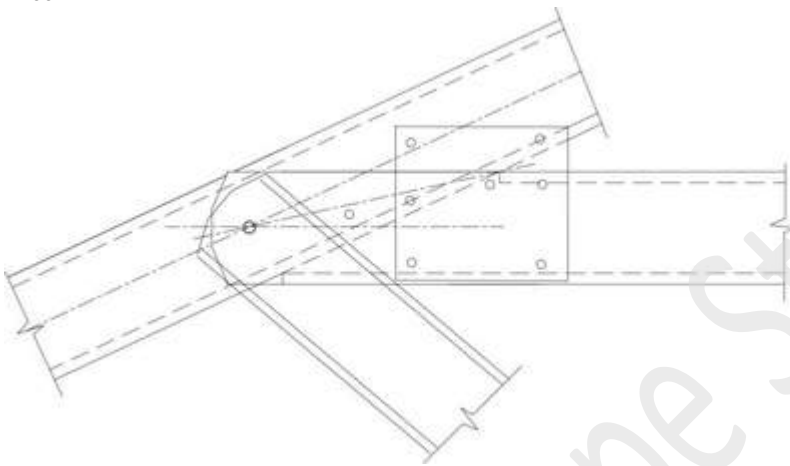

Knee strengthened with 1.5mm plate to top chord preventing buckling Use 100 x 100 x 1.5mm plate with 75mm chords Use 125 x 125 x 1.5mm plate with 90mm chords

6.5.5 Web Stiffening

Web stiffening may be required when flush truss is selected to increase the strength of the web in compression. This is done with a 200 x 35 x 1.5mm angle lintel, minimum 90mm long with the nominated number of fasteners into the connection as is shown in the figure below.

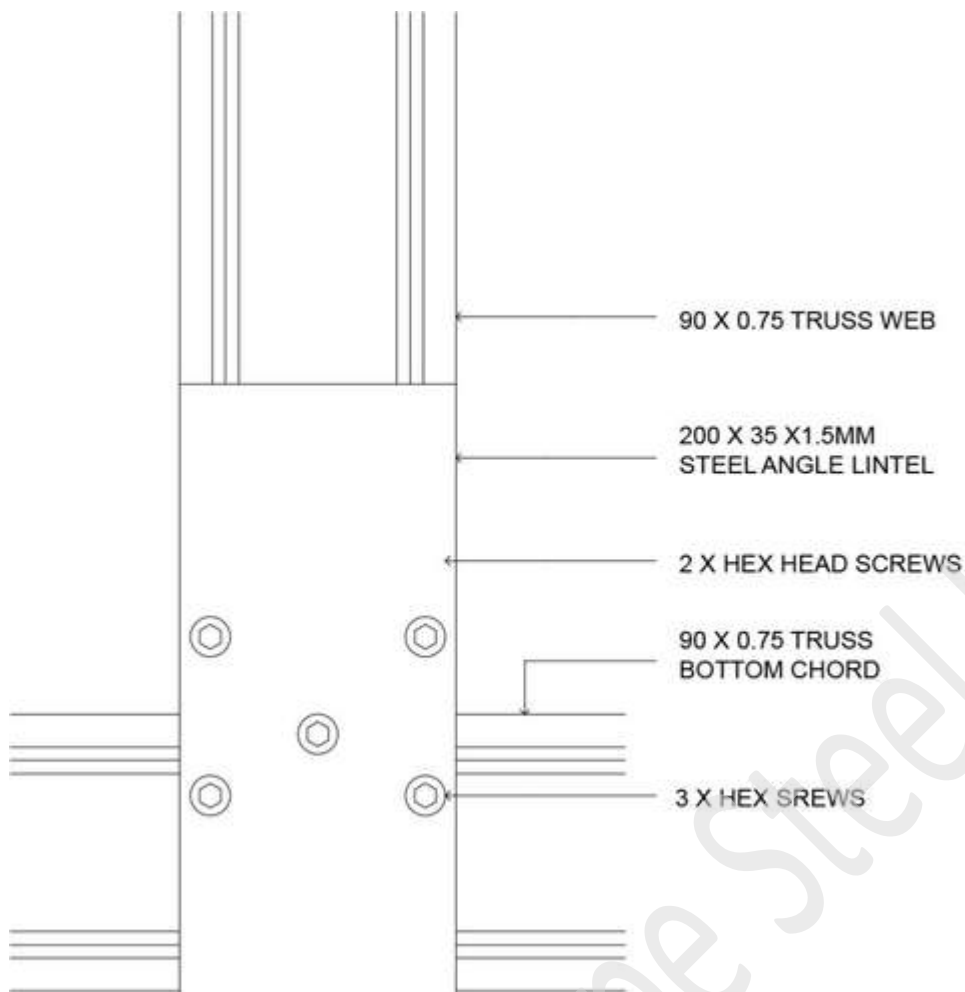
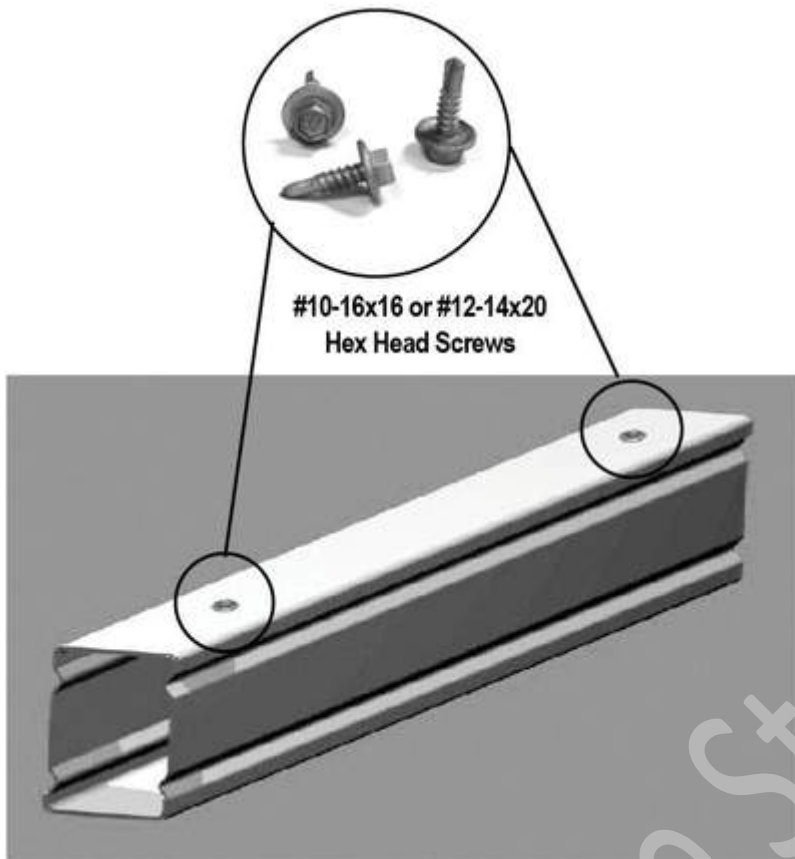

Figure 6.6 - Web stiffener

6.5.6 Chord Boxing

Where called for in the Assembly Sheet, chords are to be boxed using supplied boxing channel. Boxing is to be fixed to the inside flanges of chords using either #12-14x20 hex head self drilling screws, 10-16 x 16mm wafer head self drilling screws, or M6,0 x1P x 18,0 Smooth Top Gx Teks self drilling screws as per the diagram below. These are fixed 50mm from each end of the boxing and at 600 mm nominal centres along the boxing. Where fasteners will be fixed into the flanges of the boxed chords during the installation process in the locations described here (ie. due to the installation of tie down brackets, ceiling or roof battens, etc) they may be

omitted during the fabrication process. In this case the fabricator should provide clear instructions to the installer on the required location of screws to meet the boxing requirements.



6.5.7 Web Boxing

Where called for in the Assembly Sheet, webs are to be boxed using supplied boxing channel. Boxing is to be fixed to the web using #10 -16x16 or #12-14x20 hex head self drilling screws through each flange 50 mm from each end of the boxing and at the centre of the web.

6.5.8 Web Supports

There are 3 types of web connections at support points that are used by the ENDUROCAD® software:-

- **SUP connection** - this is used when truss webs are located above an internal load bearing wall or beam, and there is no failure in bearing.
- **SUPA connection** - this is used when truss webs are located above an internal load bearing wall or beam, and increased bearing is required by stiffening the bottom chord with a boxing section which is 250mm long in minimum 0.75mm BMT material
- **SUPB connection** - this is used when a single vertical web is attached back-to-back to a bottom chord. This is automatically inserted by the software when a support point is within 50 - 500mm of a heel connection, or where the user manually inserts a vertical web above a support.
- **SUPB-F connection** - this is used when a single vertical web is attached flush to a bottom chord. This is automatically inserted by the software when a support point is within 50 - 500mm of a heel connection, or where the user manually inserts a vertical web above a support.

SUP Connection

The SUP support is used when truss webs are located above an internal load bearing wall or beam and are inclined. In this case the numbers of reinforcing screws are indicated on the truss webs. This connection is used where there is no failure in bearing of the bottom chord.

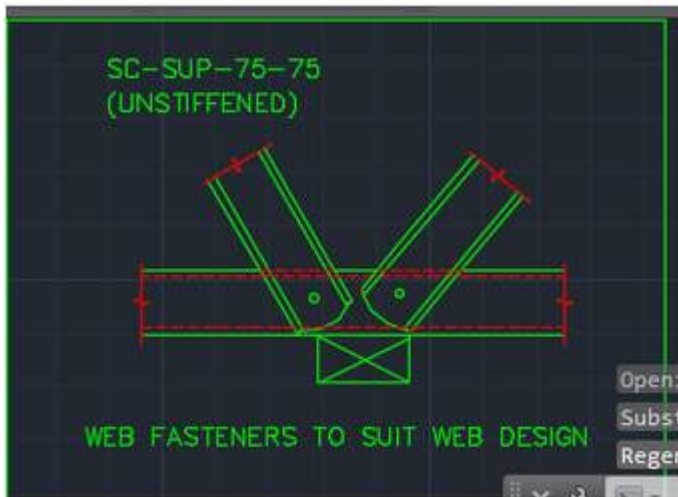

Installers may choose to add a minimum 250mm boxing piece in minimum 0.75mm material onto trusses where there is insufficient space to attach a tie down bracket between the webs. In this case, the boxing piece is attached to the chord using 3 x 12-14x20hex head or 3 x M6x1P flat fasteners on each flange of the boxing piece

SUP A Connection

The SUPA support is used when truss webs are located above an internal load bearing wall or beam and are inclined, and increased bearing is required by stiffening the bottom chord with a boxing section which is a minimum of 250mm long in minimum 0.75mm BMT material. The number of re-inforcing screws are indicated on the truss webs. This boxing piece is attached to the chord using 3 x 12-14x20hex head or 3 x M6x1P flat fasteners on each flange of the boxing piece. The numerical control data is not generated for production, and is constructed using scrap material. The truss tie down connection may be attached to either face of the truss bottom chord.

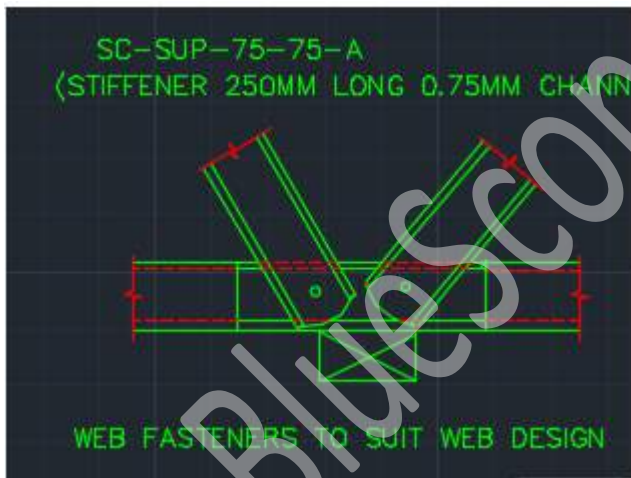

SUP B Connection

The SUPB connection is used when a support point is between 50 - 500mm of an eave, and the ENDUROCAD® software automatically inserts a back-to-back web. The minimum length of the vertical web is 195mm (if we start at the bottom of the vert web, there is 25 mm tab below the bottom chord, 45 mm up to the trusstite (attaching the web to the CL of the bottom chord), 100 mm to the next trusstite (attached to the top chord), then 25 mm tab. All add up to 195mm). This is so there is a sufficient space to operate the RW punch for a 90mm section (the punch has holes spaced at 100mm) and still fit within the part length. The tab of the web is extended past the bottom flange of the bottom chord such that the flanges of the web are perpendicular with the bottom flange of the bottom chord of the truss. The truss assembler shall manually bend or cut the tab off the truss.

The number of re-inforcing screws are indicated on the truss webs, however there shall be no fewer than 2 screws in the web to bottom chord connection - 1 x TRUSSTITE and 1 x 12-14x20 hex head fasteners.

The design values for these connections are derived from the HEEL-HS connections.

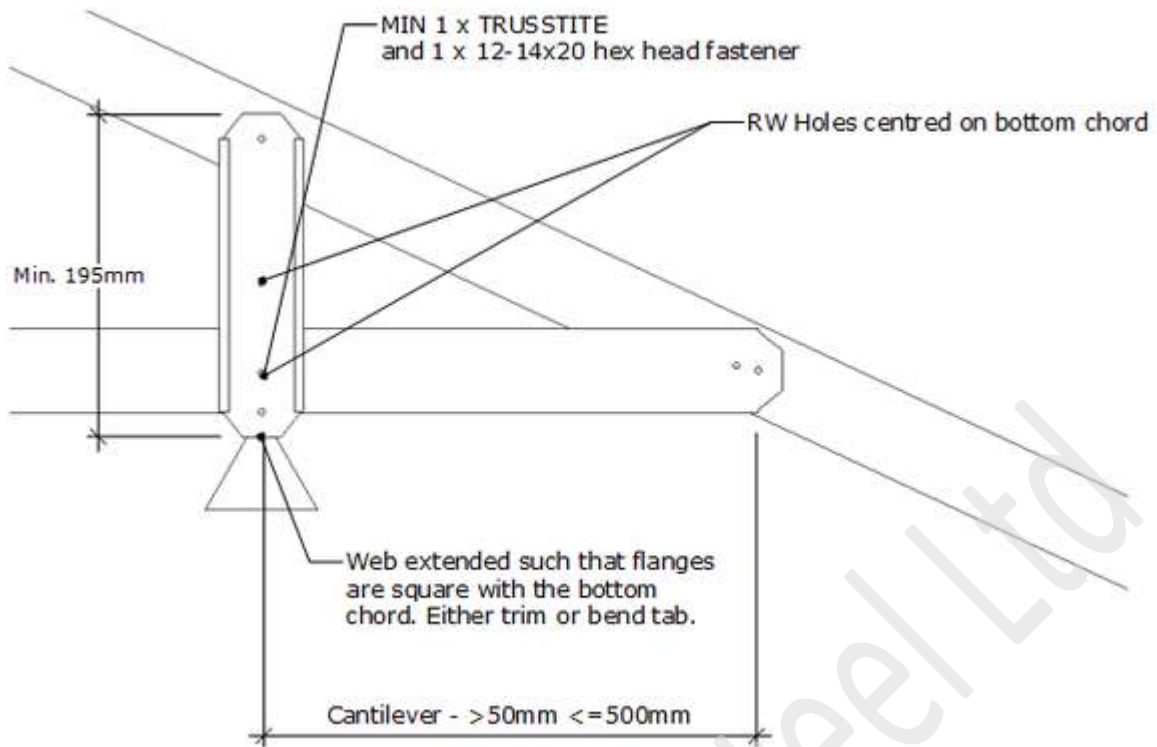

SUPB Connection when cantilever is between 50mm - 500mm from heel connection

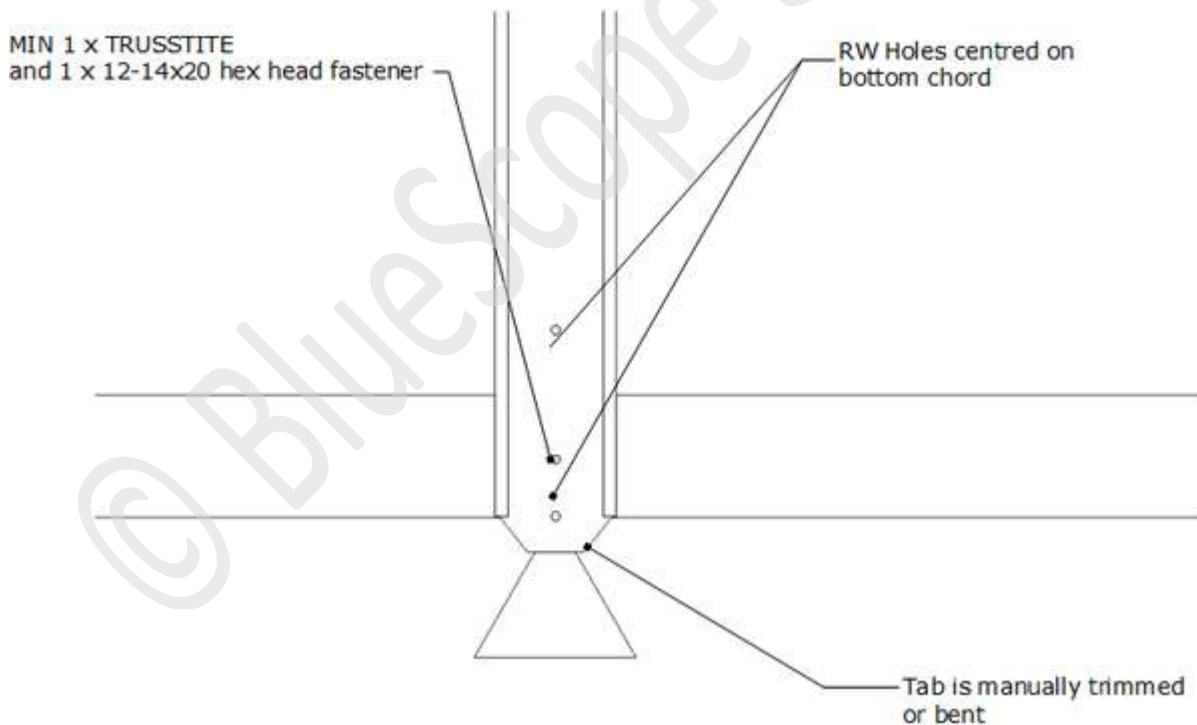

SUPB Connection when user manually selects to make web vertical above a support point

SUPB-F Connection

This is a variation on the SUPB connection however the web is a flush web. The value for this connection is derived from the HEEL-HS-F connections.

6.5.9 Elbow Stiffening

From the appropriate connection drawing, identify the location and type of stiffener and/or the screws required for Elbow stiffening.

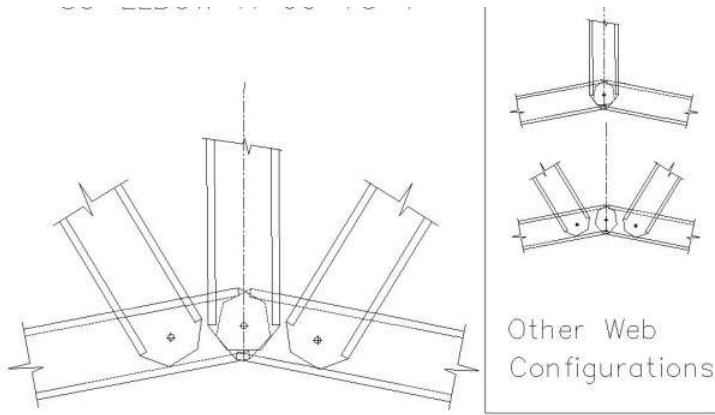

1 TRUSSTITE to CHORD INTERCEPT

Elbow Stiffener A

120mm x 35mm x 1.5mm ANGLE (MIN)
210mm LONG

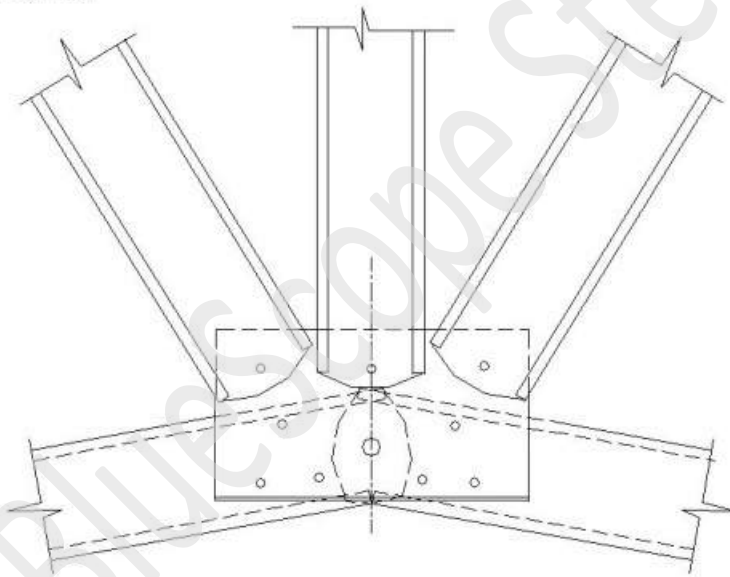

TRUSSTITE + 6X12-14X20 HEX SCREWS

Elbow Stiffener C using an Elbow Plate

The detail for the elbow plate is at this link - [Smarruss Elbow Plate P11867.pdf](#)

6.6 Boxed Eaves

Boxed eaves can apply to trusses, common rafters or truss hips, and provide supports for the eaves lining. The distance can be adjusted to suit the dropoff height and the distance from the pitching point.

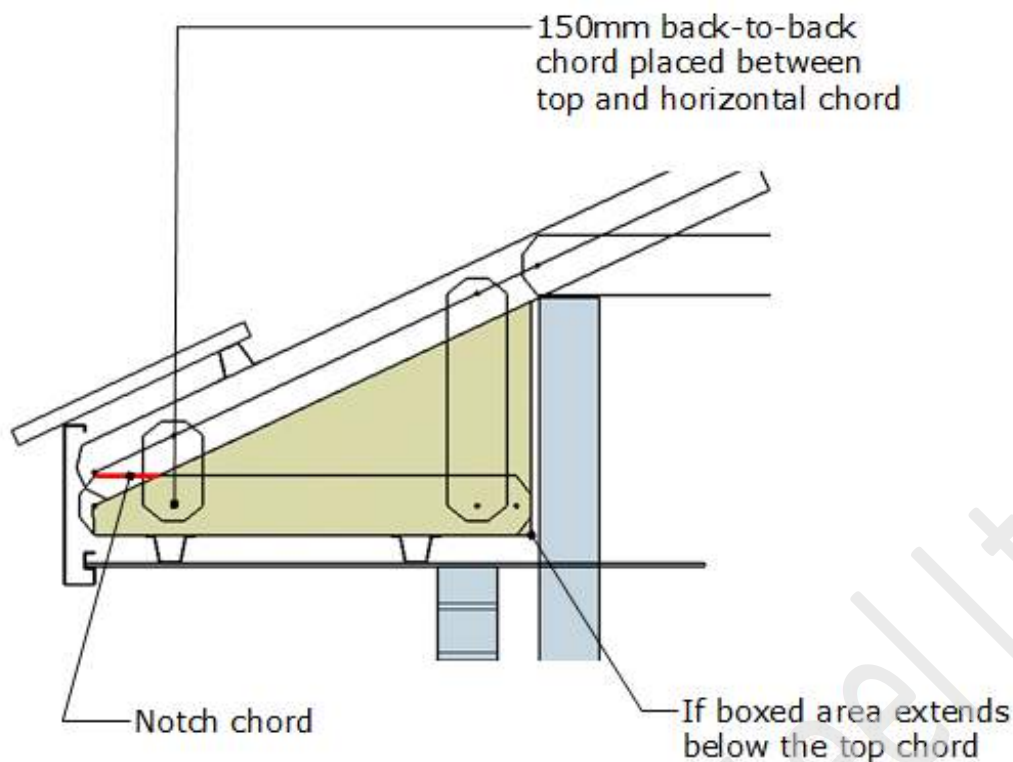

Boxed Eave Detail

It is possible that locating holes do not line up between the horizontal chord in the boxed eave and the locating hole in the truss top chord. In this case a 150mm long vertical back-to-back web is inserted to locate the position of the horizontal chord. In the event that a flush truss is being used this vertical back-to-back web may be removed and replaced with 2 x 12-14x20 hex head fasteners or a minimum 100 x 100mm plate to keep the bottom chord in place.

7.0 Roof construction

7.1 General and design

ENDUROTRUSS® Framing System roof trusses have been designed to engineering standards and it is essential that to perform, as designed, they are handled, erected and braced correctly. The following recommendations apply to roof trusses on standard domestic and light commercial buildings.

The trusses are designed by the ENDUROCADD® design software to suit the specific roof and ceiling geometry and loads applicable site conditions. Additional loading such as Solar Units, Hot Water Tanks, Air Conditioning, etc. require special consideration at the time of design and the placing of these additional loads must be referred back to the designer.

Wind load is an important factor in the design and performance of roof trusses. Ensure that the correct design wind loads have been used and that the tie down of trusses to the wall structure is carried out in accordance with the construction documentation.

7.1.1 Prior to construction

Before commencing roof construction:

1. Check the support structure in particular the plan dimensions, the plumb and level of the support structure, the straightness of the supporting walls or beams and that the structure is adequately braced, stable and tied down. Rectify support structure if found deficient prior to proceeding.
2. Roof trusses must be inspected and any damaged parts must be reported immediately to ensure correct rectification. Approval for site rectification should be obtained from the truss manufacturer.
3. Check that the ENDUROCADD® software generated truss layout matches the building and that all truss set-out dimensions and truss identification marks have been provided.

Note:

Truss orientation and Position

The layout drawings specifies the correct truss orientation. **The front of the truss is the flat (unlipped) face of the truss chord. Looking at the truss from this direction identifies the Left and Right hand truss ends.** Ensure trusses are orientated as shown on the truss layout. Trusses must be positioned within 5mm from their specified position.

Roof Truss Numbering

During the detailing / fabrication process the roof trusses are numbered to accurately identify them. These numbers are shown on the roof truss layout and form part of the truss branding (refer Section 6). Trusses may have identical shape but may differ in the web configuration or internal connections. Ensure that the correct truss is used in its specified location on the roof.

Safety

Ensure that all barriers or scaffolding used in order to comply with safe work practices are installed so as not to damage or overload roof components.

7.1.2 Internal load bearing

Where trusses are supported by internal walls, the truss web configuration will be designed to satisfy the load concentration at the load bearing point. Ensure that the truss is installed such that bottom chord to web connections are within 5mm to the support points. The builder should ensure that these loads are accommodated in the foundation design.

7.1.3 Fasteners

Generally for roof construction #12-14x20mm hex head self-drilling Class 3 screws are used for all structural connections. Use the recommended number shown on the drawings.

In connections, maintain a minimum fastener spacing of 17mm and minimum distance of 17mm to the end of sections and a minimum 10mm from the edge. Refer to **Section 6.5** for a diagram showing locations.

7.2 Roof truss set-out

Prior to lifting any trusses into place, mark out the truss locations on the top wall plate, using the supplied Roof Framing Layout as a reference. The trusses may be aligned to load bearing studs. In cases where it is not aligned, sufficient capacity shall be provided for top plate using lintels or stiffeners. Check that design truss spacings have not been exceeded.

If trusses are fixed to the support structure using brackets these are often installed in the marked positions prior to positioning the trusses.

Alternatively service holes may be punched in the top plate above studs to which trusses are to be fixed. These service holes are to act as location points and allow a 25 x 3 x 200mm tie down strap to fit through and fix to the face of the stud.

It is generally best practice to install Girder trusses and Hip ends before proceeding with the installation of standard truss runs.

Whilst erecting roof trusses ensure that each truss is erected in the correct position, correctly orientated with chords aligned with the roof slopes and plumb (using a spirit level).

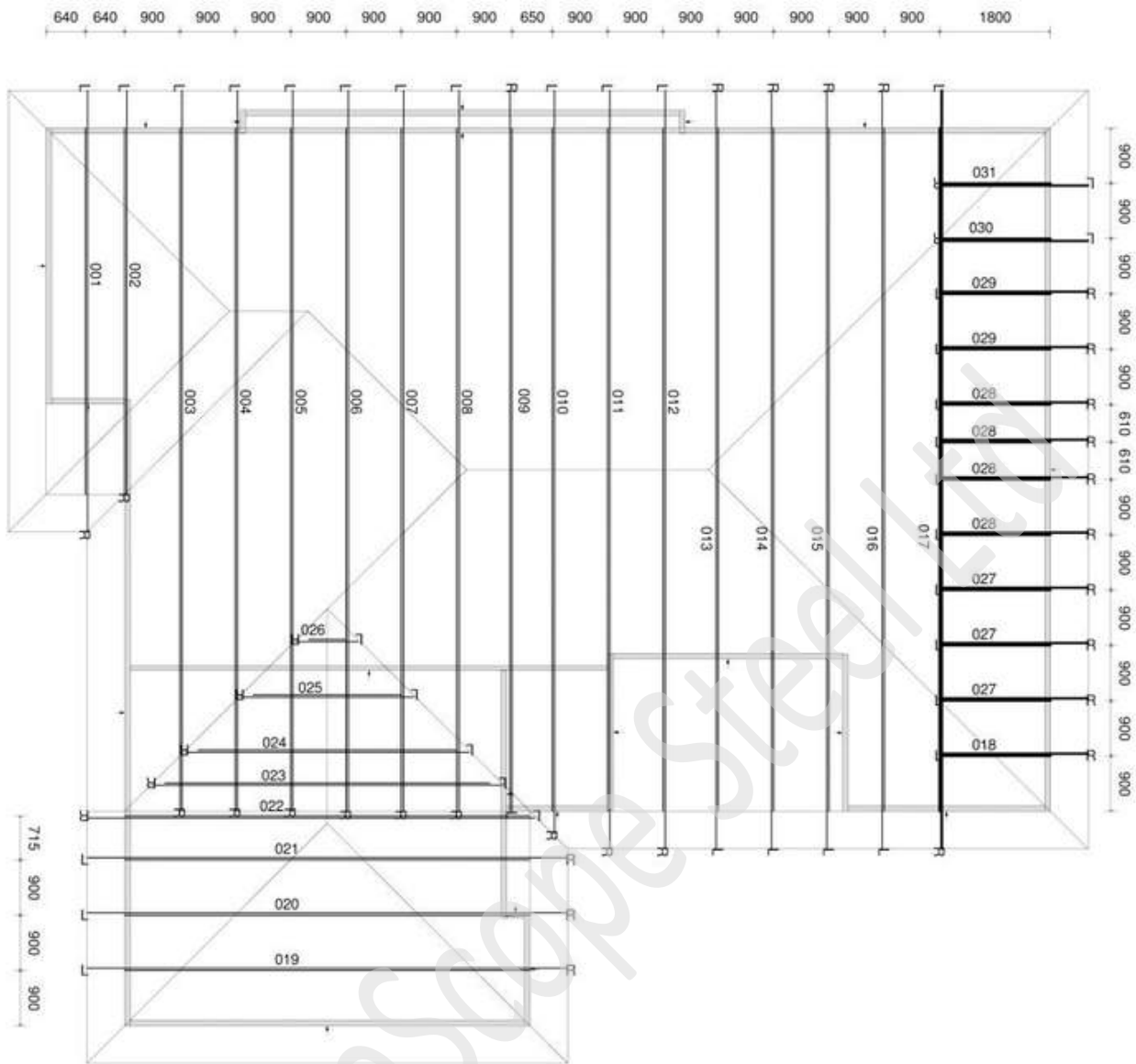

Figure 7.1 Truss layout drawing as generated by ENDUROCADD®

7.3 Gable End Construction

There are essentially three types of gable ends though some variations may be utilised with different wall and roof cladding types.

End support may be provided by using a gable end truss or by extending the end wall to the roof plane for batten support.

Where a gable end truss is used it is usually positioned just inside the end wall where the ceiling battens may be fixed directly to the truss bottom chord. Framing members are attached directly to the truss outside face to support the wall cladding. These framing members may consist of battens or wall studs and must be designed to span between the ceiling plane and the roof plane. Temporary bracing should be employed to maintain stability during erection. Ensure the truss is installed plumb and correctly positioned so that the external cladding line is maintained. Refer to **Section 7.9.1** for Temporary bracing.

If the gable end wall is extended to the roof plane to provide wall cladding support, the studs must be designed to span from floor to roof. If there is a ceiling plane below the roof plane then the studs must be fixed so as to transfer end wall wind loads into the ceiling plane. Refer **Figure 7.2** for connection details.

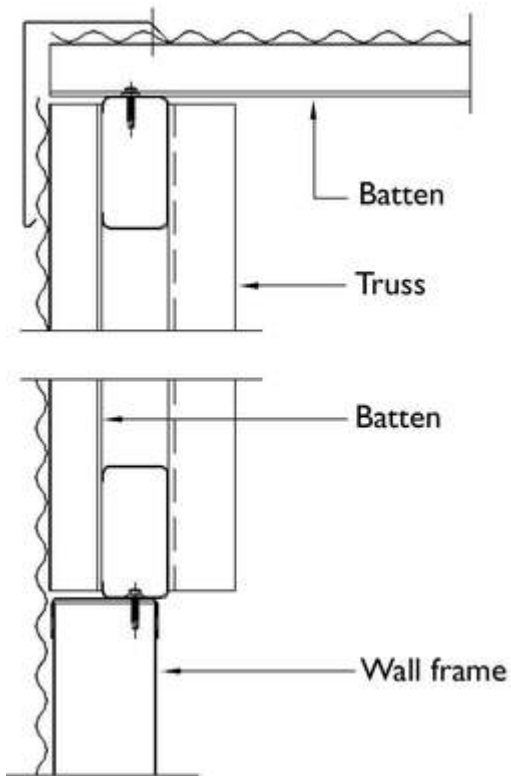

Figure 7.2 Connection detail

Type 1 Flush Gable

For flush gables, roof battens and end wall claddings are directly supported by a raked end wall or a truss fitted with cladding support members. Refer to **Figure 7.3**.

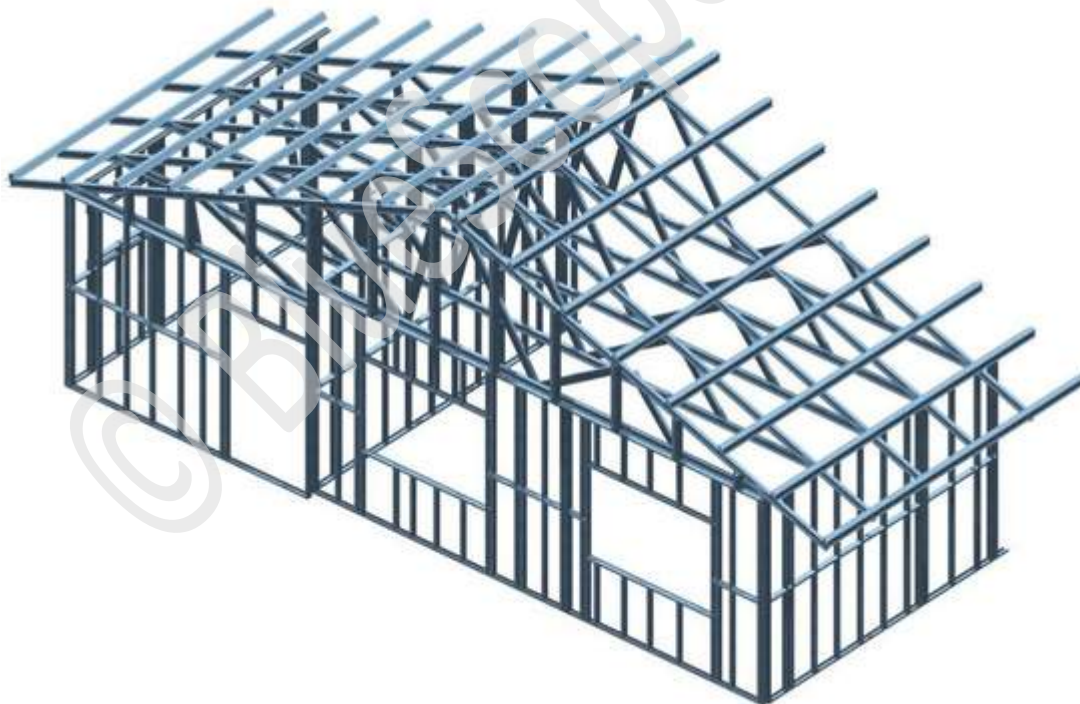

Figure 7.3 Framing and truss configuration for a flush gable

Type 2 Small Verge

In non-cyclonic areas where verges are less than 450 mm, support can generally be provided by the battens as shown in **Figures 7.4 a, 7.4b and 7.5**. A Gable ladder manufactured from wall framing stud and plate is installed under the batten projections to carry the

soffit linings, barge fascia and flashings. Where specified, additional ladder support can be provided by doubling the roof battens one truss bay into the roof or by providing structural members such as channels or RHS in lieu of batten support.

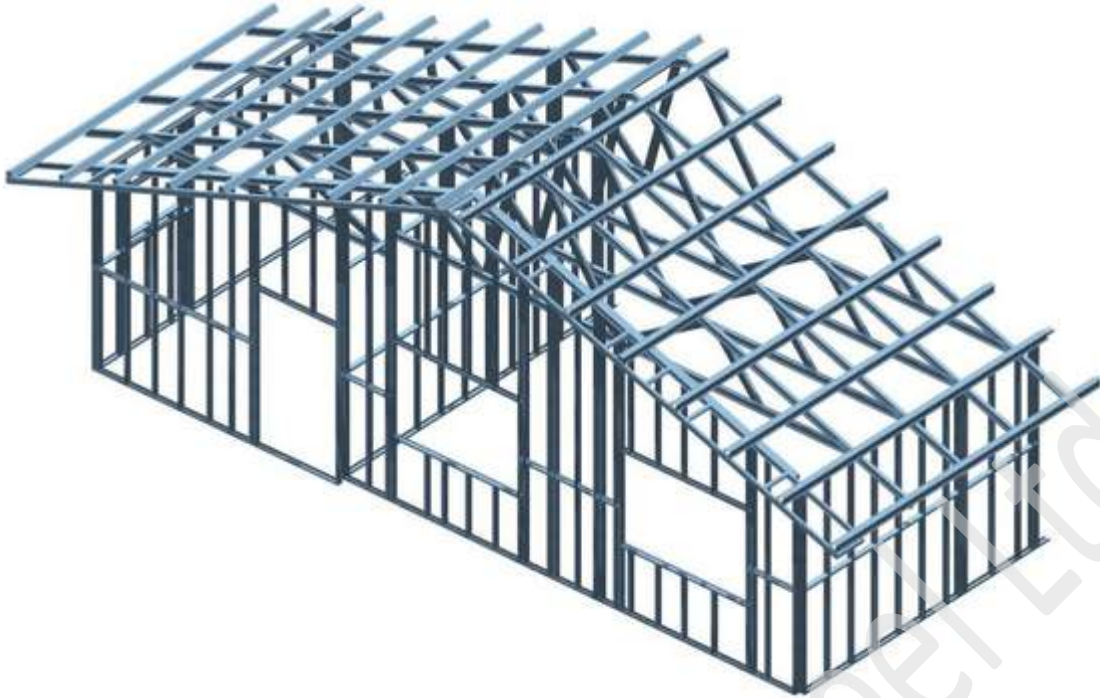

Figure 7.4a Small verge, supported by wall framing

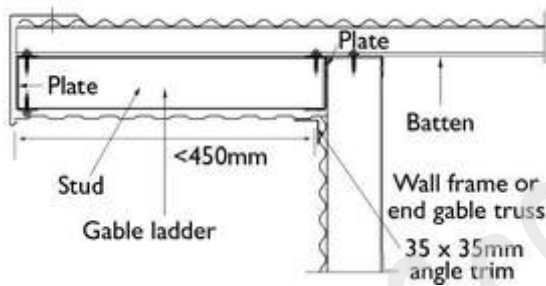

Figure 7.4b Connection detail

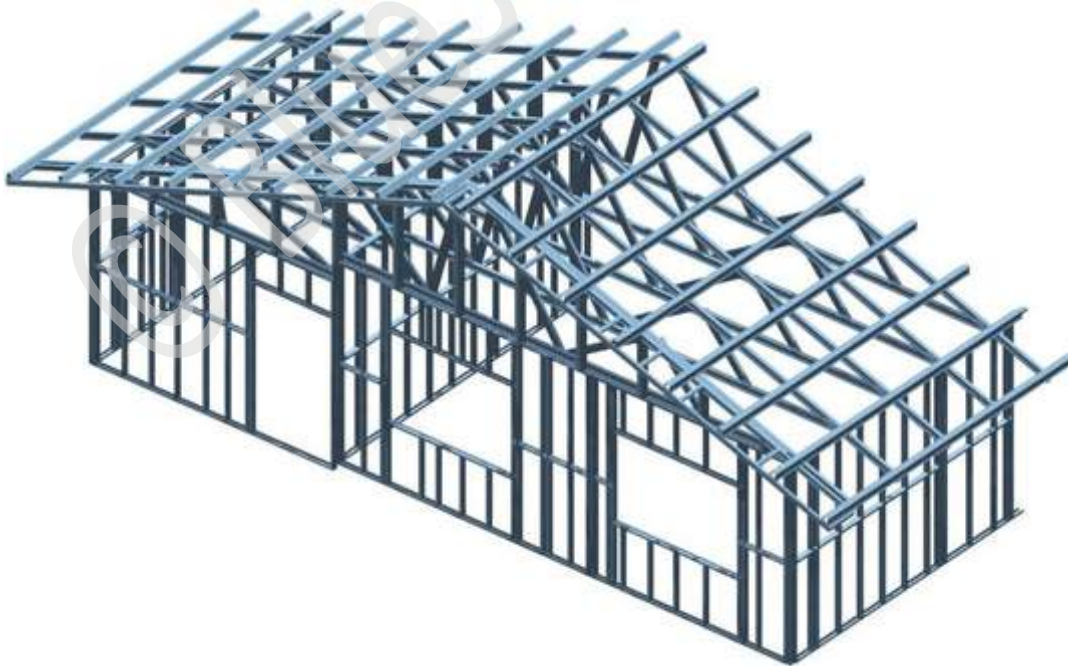

Figure 7.5 Small verge, supported by gable end truss

Type 3 Large verge overhangs

Where insufficient verge support is offered by battens or structural members a Type 3 gable end may be required. Here the end wall is extended below the roof plane enabling a verge ladder to be fixed to the first truss back from the gable end and connected to the gable end wall top plate and cantilevering to form the verge framing as shown in **Figure 7.6a**. The gable ladder must be designed to suit the load condition, the cladding material and the verge overhang.

For a 75 x 1.0mm or 90 x 1.0mm ladder frame supporting sheet metal cladding, a maximum verge overhang of 900mm is acceptable in non-cyclonic areas using verge framing members at 1200 max centres, and 600mm is acceptable in cyclonic areas using verge framing members at 900mm max centres.

For a tile roof a maximum overhang of 600mm is permitted in non-cyclonic areas only. Larger overhangs can be achieved by modifying the ladder and should be referred to an engineer.

The steps are as follows:

Step 1: Study the entire set of architectural and fabrication drawings.

Step 2: Erect gable trusses in accordance with **Section 7.3**.

Step 3: Install gable ladders for small verges by fixing each batten to both gable ladder plates using 1 #12-14x20 screw per batten flange. For large verges, the gable ladder is aligned with the top chord and cantilevers over the end gable wall (or truss).

Step 4: Fix the gable ladder to the truss or gable end wall using 2 #12-14x20 hex head screws at 1200mm centers for non-cyclonic areas and 900mm centres for cyclonic areas.

Step 5: Fix battens to the end truss or gable end wall (where extended to the roof plane) and the gable ladder at the verge projection.



Figure 7.6a Large verge overhangs

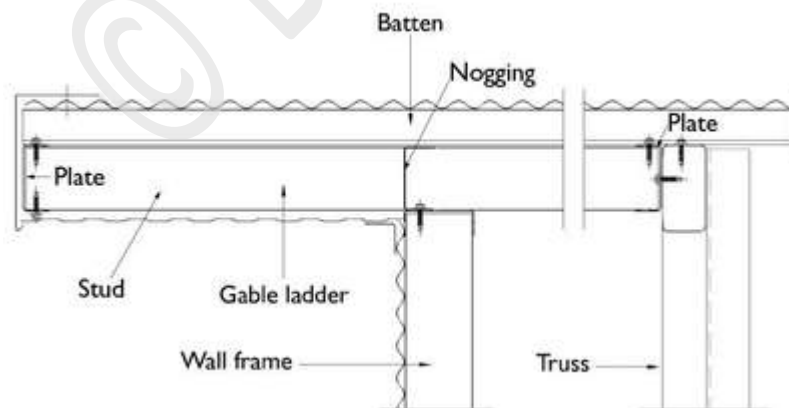

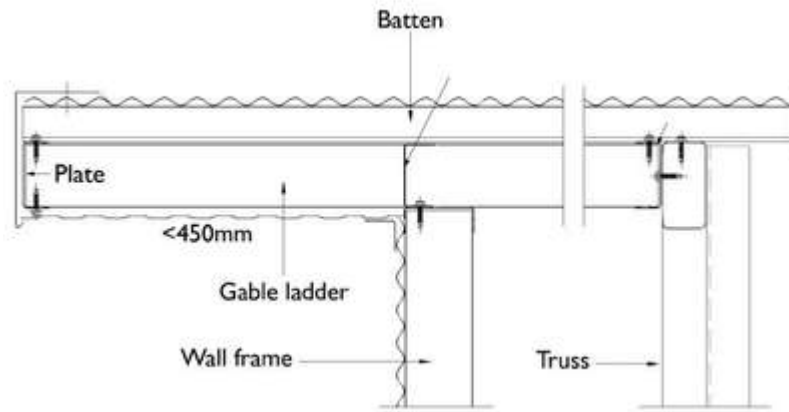

Figure 7.6b Connection detail

7.4 Hip End Construction

Three options are available for hip end construction:

- Type 1
- Type 1A
- Type 2.

Each option has different configurations for trusses and rafters although the general assembly method is the same. There are also two options for hip rafter construction which can be used with each of the hip end and rafter construction methods. A description of these hip end construction options and how they are installed is described in **Sections 7.4.1, 7.4.2 and 7.4.3.**

7.4.1 Type 1 Hip construction

Type 1 Hips use single rafters that may be boxed and run from the eaves line to 43mm beyond the rafter IP. Toes on common rafters face towards the center of the building.

Standard ENDUROTRUSS® Framing System hip end trusses (Type 1 Hips) are generally placed parallel to and at the same spacing as the main roof trusses.

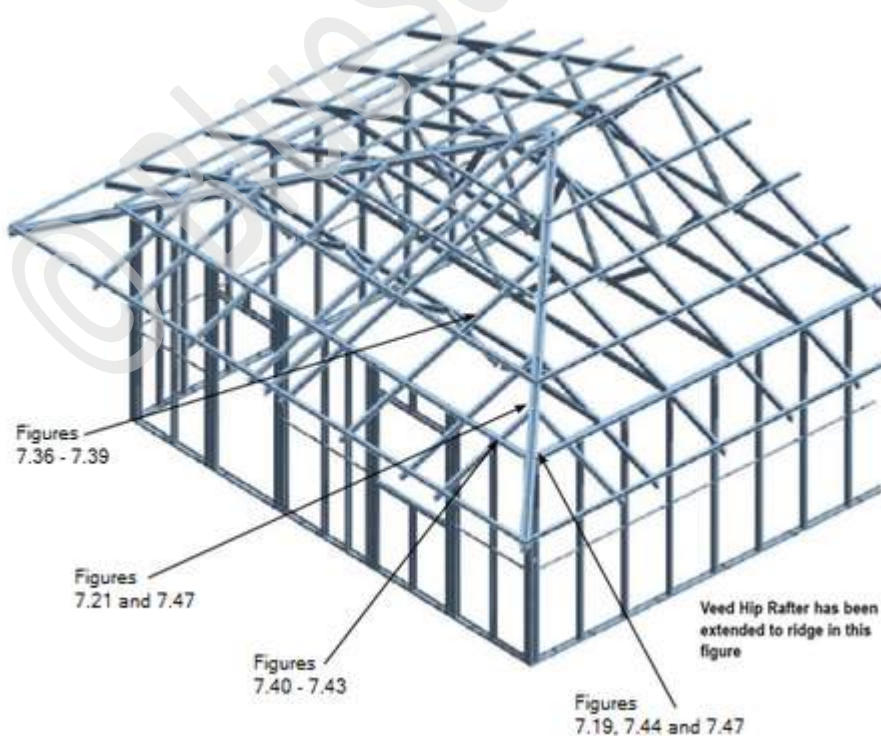

Figure 7.7 Type 1 hip construction

Constructing Type 1 hip roofs

To construct a Type hip roof:

Step 1: Study the entire set of architectural and fabrication drawings.

Step 2: Set out and mark truss positions as per **Section 7.2**.

Step 3: Install fixing brackets to support structure in marked positions.

Step 4: Lift trusses into position, ensuring the webs of the trusses face the hip end wall.

Step 5: Stand the first station truncated truss in its set-out position and, fix two #12-14x20mm hex head self drilling screws through the fixing bracket at each heel connection into the truss chord. If erection screw positions clash with truss manufacture fasteners remove these screws and replace with the erection screws through the bracket and into the chords in the same location.

Step 6: Temporarily brace the truss and ensure it is plumb and straight. This can be done using batten or roof bracing material fixed to the end wall and to the horizontal top chord of the truss.

Step 7: Repeat steps **3** and **4** when installing the second, third and subsequent station truncated trusses until all truncated trusses are positioned in accordance with the roof layout.

Step 8: Hip rafters are provided at hip ends to support roof battens and creeper rafters. There are three types of hip rafter options available in the ENDUROTRUSS® system.

Note: The trusses align with the top chords of the truncated trusses via dimple holes that are punched in both the rafters and truncated trusses.

A Boxed Hip Rafter extends from the fascia corner at the eaves to the end of the hip line. It may be fixed to another hip rafter as shown in **Figure 7.27**. Depending on the cladding material and wind loads the fixings of the hip rafter may vary. For tile roofs, two screws are placed through the truncated top chord into the hip rafter as shown in **Figures 7.43** and **7.44**. For bottom of hip rafter, a shear connector is used as shown in **Figures 7.47** and **7.48**.

A Vee Plate Hip Rafter do not continue to the ridge line. The inner channel of the Vee extends from the fascia line to just past first structural truss. The outer channel of the Vee stops short of the first structural truss so that it does not clash with any members of this truss such as the horn, and can be supplied as a standard part. The hip rafters are fixed with 2 #12-14x20 hex head screws from underside of wall top plate through the hip rafter flange.

Step 9: Creeper rafters are generally designed to extend from the top chord of the truncated truss adjacent to the knee connection, to the fascia line running perpendicular to the truss. Mark the overhang length on the jack rafters using the truss overhang as a reference. Position the rafter with the correct overhang and in the location shown on the layout. Ensure the common truss spacing is not exceeded in setting the rafter positions. Fix to the truss top chords as shown in **Figures 7.42** to **7.44** and the external wall top plate in accordance with **Figures 7.40** to **7.43**. Continue to install all creeper rafters until the hip end is complete.

Step 10: Creeper rafters are supported by the hip rafter and the external wall. They are generally short rafters near the corner of the building. Ensure sufficient back span is provided to give the installed rafter sufficient strength. Mark the overhang length on the creeper rafters as per the jack rafters. Install the creeper rafters in the locations shown on the layout drawing fixing to the creeper rafter and the wall top plates as shown in **Figures 7.40** to **7.43**. Fix creeper rafter to hip rafter as shown in **Figures 7.26** and **7.27**, **7.32**, **7.42** to **7.49**, and **7.53**.

Note: When all trusses are erected, install wind bracing as specified in **Section 7.9** Roof Bracing.

7.4.2 Type 1A Hip construction

Type 1A is a variation on the Type 1 Hip. The truss layout and design is identical to the Type 1 Hip however the rafters are triangulated between the first station truss and the hip end wall by the addition of a horizontal and vertical member.

Each rafter is thus a simple truss with an extended top chord as shown in **Figure 7.8**, creating a hybrid of a Type 1 and Type 2 hip. The purpose of these members is to plumb the first station truncated truss, simplify erection and enable simple installation of rafters where the pitching line is outside the support wall.

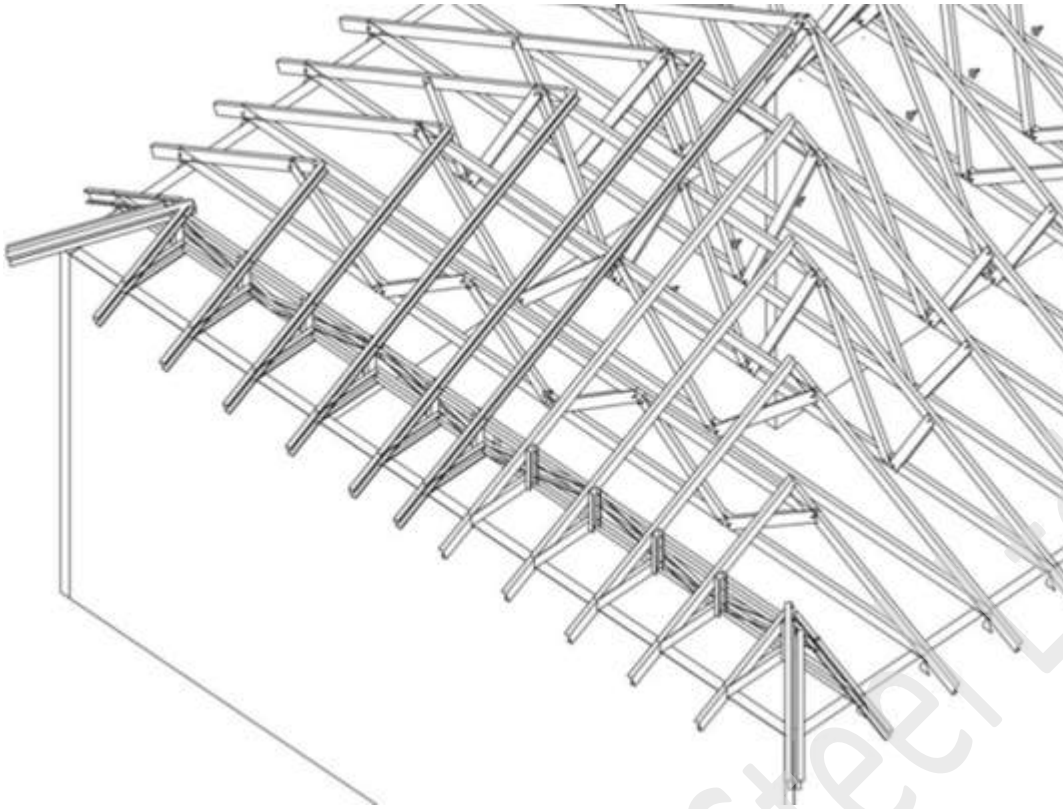

Figure 7.8 Type 1A hip construction



Figure 7.9 Installation of a Type 1A hip truss

7.4.3 Type 2 Hip Construction

Type 2 Hips use half trusses supported by a girder truss instead of rafters. These half trusses **must be flush** and are placed in exactly the same location as common rafters, generally with chord toes facing towards the hip centre.

Type 2 Hip ends may also require truncated half trusses to run down the roof line. In this event the same rules apply for setting Horn IP, Hip IP and Rafter IPs on the horizontal top chord of the truncated half trusses as shown in **Figure 7.10**.

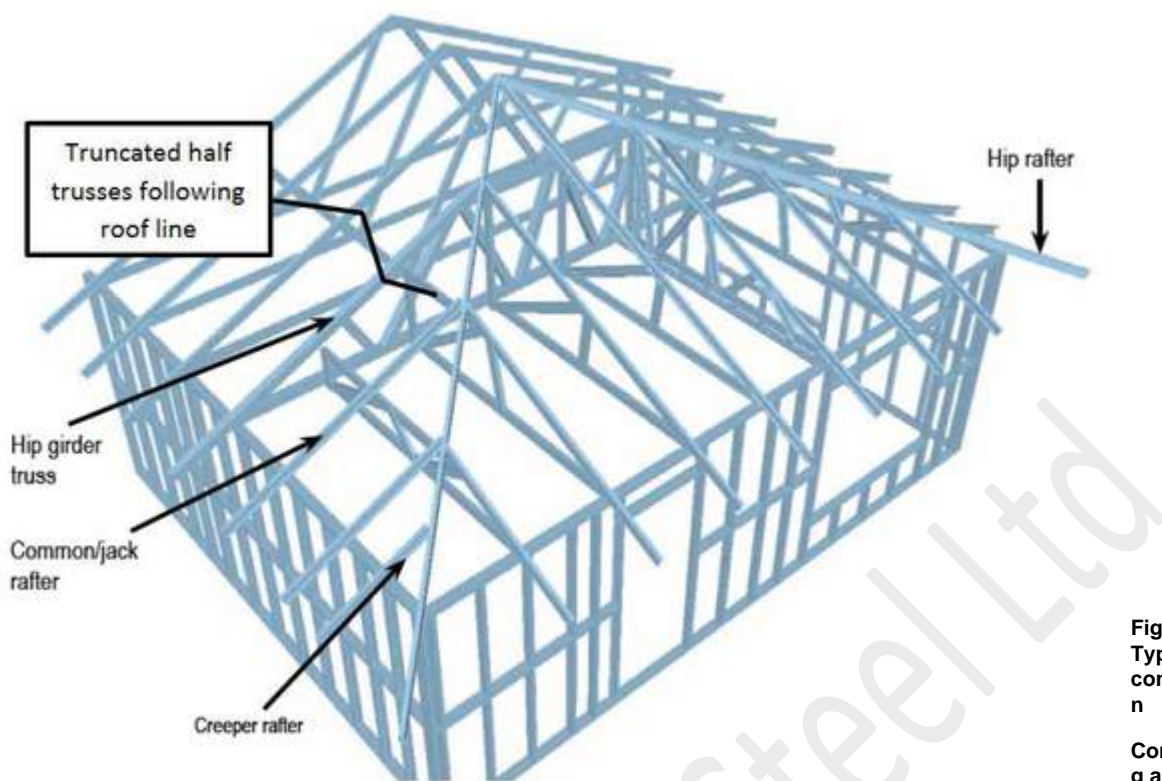

Figure 7.10
Type 2 hip construction

Constructing a Type 2 Hip roof

To construct a Type 2 Hip roof:

Step 1: Study the entire set of architectural and fabrication drawings.

Step 2: Set out and mark truss position as per **Section 7.2**. Mark Bridge Truss positions on the Hip Girder Truss bottom chord. If the hip girder is a double truss, ensure that the bridge truss location is marked on the correct truss as specified in the girder truss fabrication sheet.

Step 3: Install fixing brackets to the wall top plates to fix girders, bridge trusses and rafters in marked positions.

Step 4: Lift girder trusses into position. Note the bottom chord of the Girder trusses is always boxed and that the flat face of the girder faces the hip end wall. If the hip girder is a double truss, install the first ply of the girder truss that is closest to the hip end wall.

Step 5: Stand the hip girder trusses in its set-out position and fix two #12-14x20mm hex head self drilling screws through the fixing bracket at each heel connection into the truss chord. If erection screw connection clash with truss manufacturer fasteners, remove these screws and replace with the erection screws through the bracket and into the chords in the same location.

Step 6: Temporarily brace the trusses and ensure that they are plumb and straight. This can be done using batten or roof bracing material fixed to the end wall and to the Horizontal top chord of the truss.

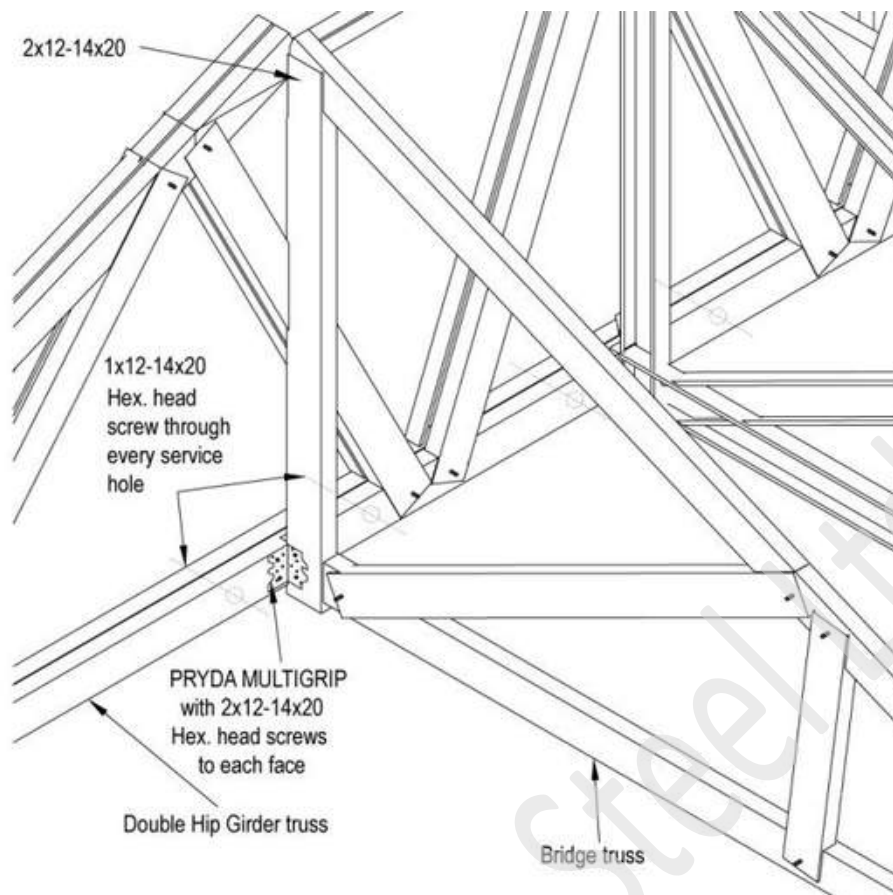

Figure 7.11 Bridge truss to hip girder truss connection

Step 7: Bridge trusses are designed to span between the hip girder and end wall. Position bridge trusses at the locations marked on hip girder truss bottom chord and wall top plate. Install bridge trusses (half trusses) and fix to the external wall top plate using the tie down specified. Refer to **Section 7.8** for tie down options. Fix the bridge truss to the top chord of the girder truss with 2/12-14x20 screws through the web of top chord into the end vertical web of the bridge truss.

Fix the bridge truss to hip girder bottom chord as shown in **Figure 7.11**. Using a multigrip fixed with 2x12-14x20 hex head screws. The tab on the bottom chord may need to be cut or bent for fixing. Ensure bridge truss spacing is not exceeded.

Step 8: A single girder truss can be installed using either a 25 x 5mm strap tie down or a 50 x 50 x 3mm angle tie down as is shown in **Figures 7.14** or **7.15**. Install the second ply girder truss (if applicable) with the toes of both trusses facing each other and fix it to the brackets as shown in **Figures 7.12** or **7.13**. Install 1x12-14x20 Hex Head screws through **every** service hole provided on the bottom chord to connect the two trusses together as shown in **Figures 7.11** and **7.16**.

Step 9: Refer to step 8 of **Section 7.4.1** for hip rafter installation. In case of Veed Rafters, the difference is that the shorter rafter is located on the inside of hip while the longer rafter (supported by the truncated truss) is on the outside of the hip.

Step 10: Refer to step 9 of **Section 7.4.1** for common / jack rafter installation.

Step 11: Refer to step 10 of **Section 7.4.1** for creeper rafter installation.

Note: When all trusses are erected, install wind bracing as specified in **Section 7.9** on Roof Bracing.

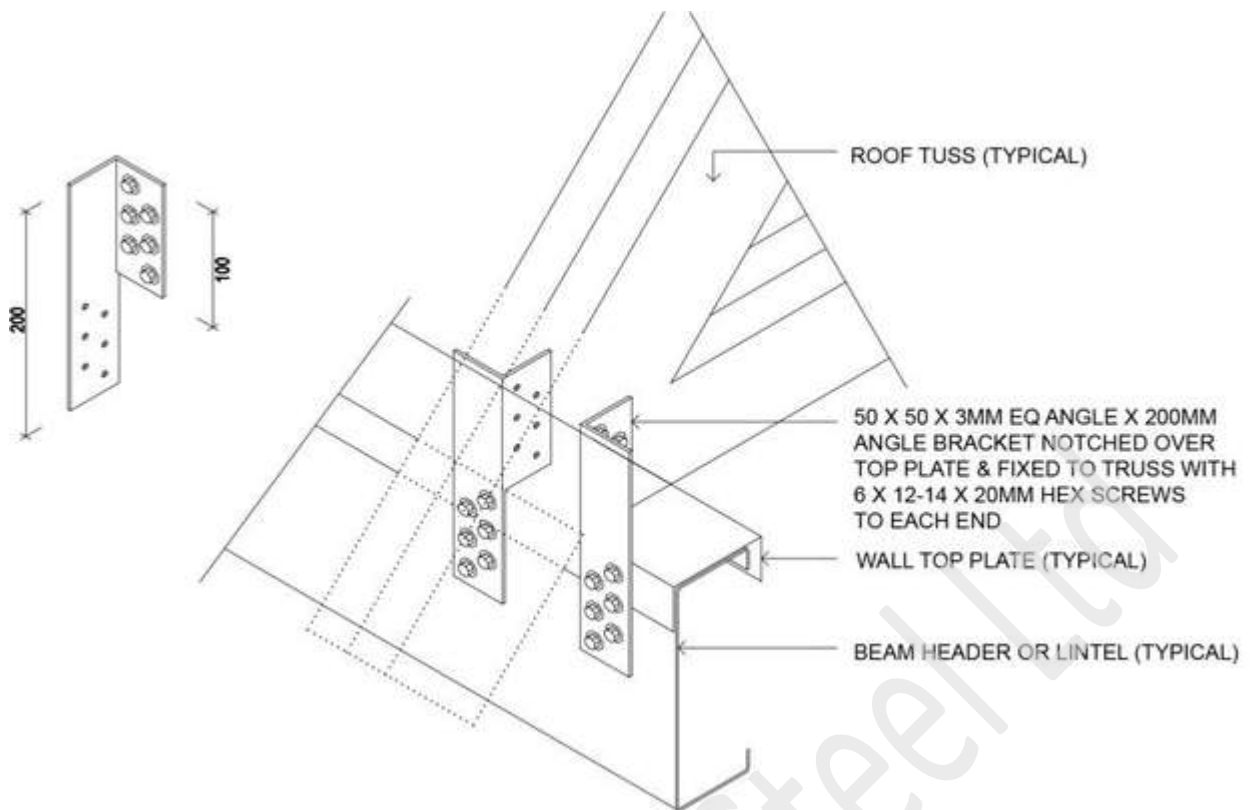

Figure 7.12 Girder truss to wall top plate connection using angle brackets

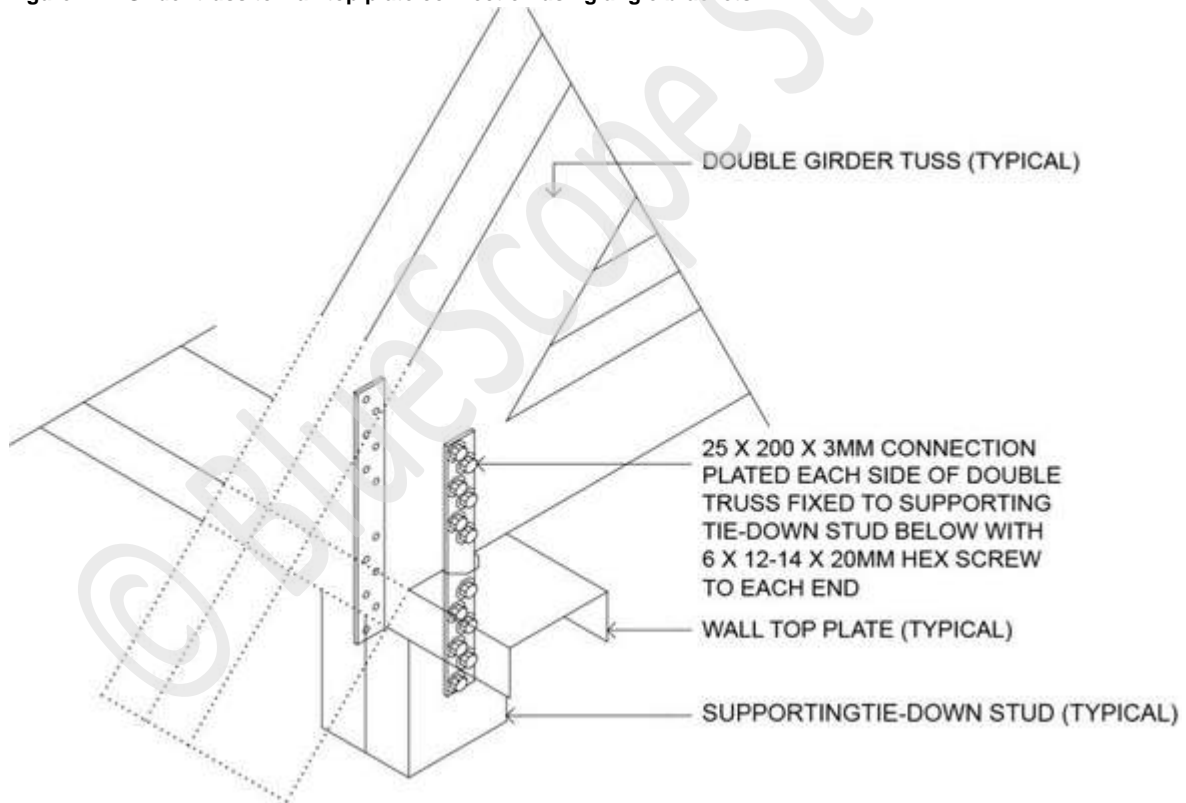

Figure 7.13 Girder truss to wall top plate connection using strap tie downs

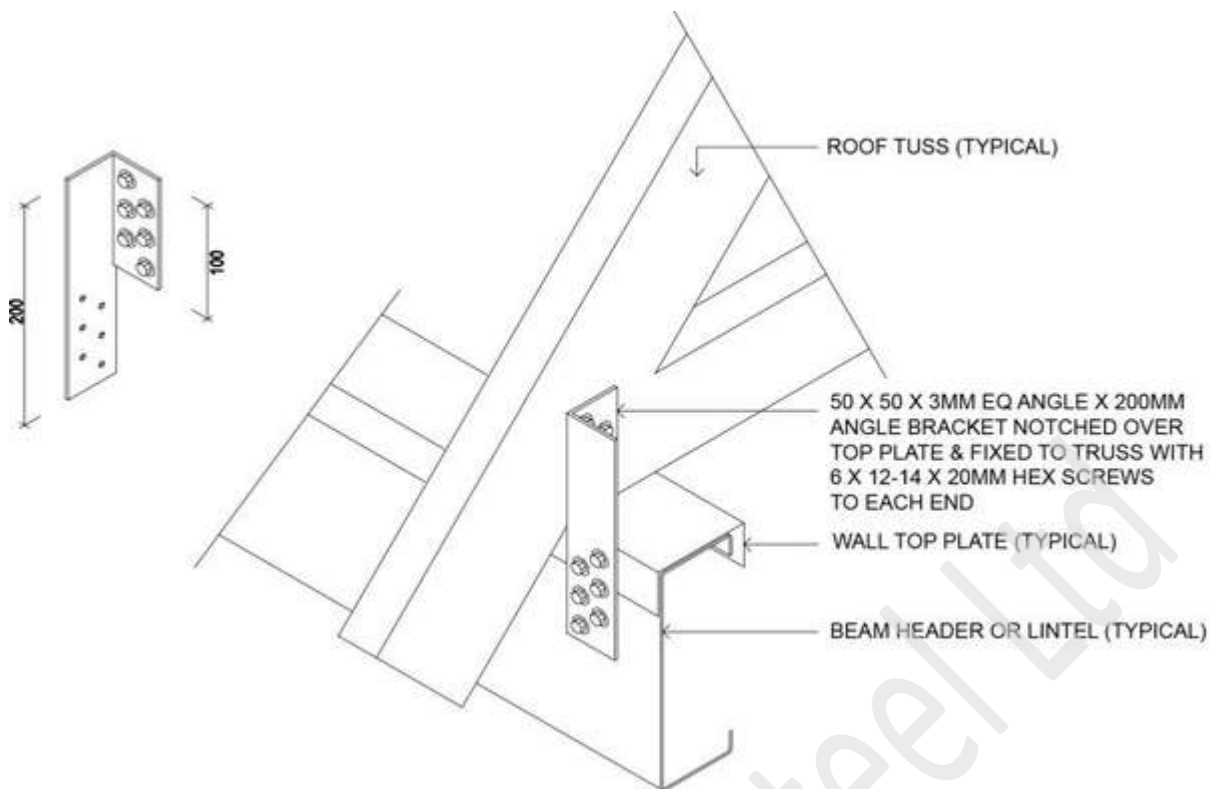

Figure 7.14 Single girder truss to wall top plate connection using angle tie downs

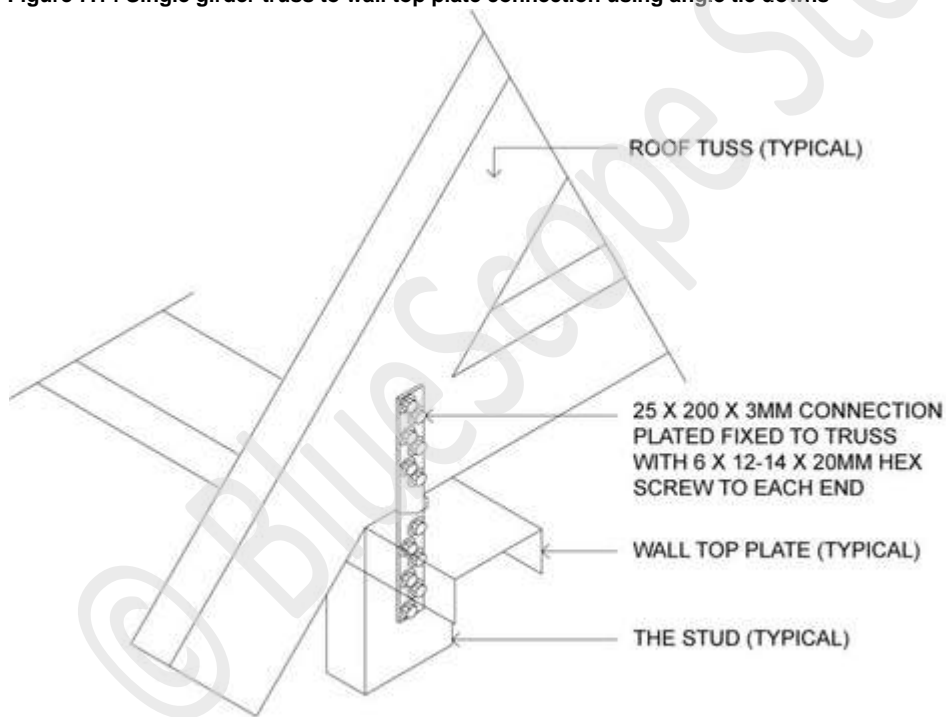

Figure 7.15 Alternative Truss Hold down for girder trusses

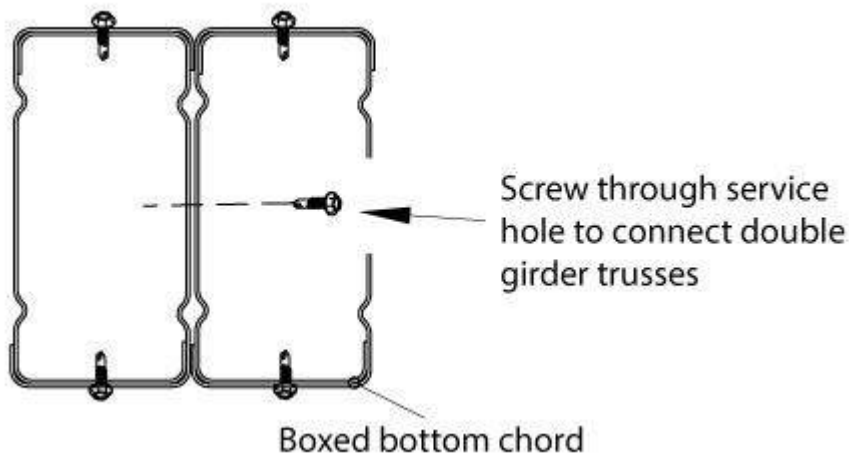
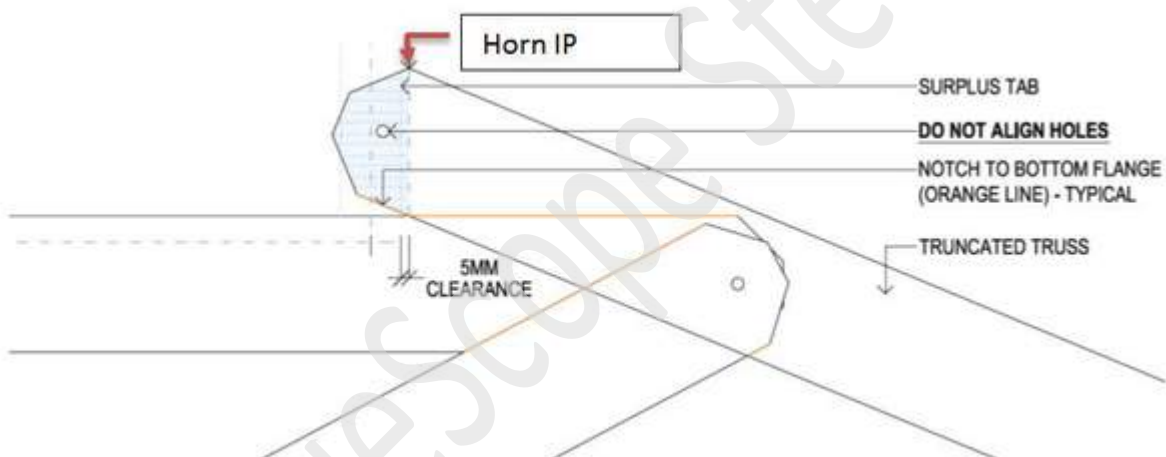

Figure 7.16 Connection between double girder trusses

7.4.4 Truncated trusses

Truncated trusses are key to setting the location of hip and common rafters. The horn of a truncated truss top chord extends past the horizontal top chord and the bottom flange of the sloping top chord is notched so that the horn can be bent 45 or 90 degrees depending on whether a hip or common rafter is to be placed next to the horn. The notching of the horn is shown in Figure 7.17.



If a hip rafter is to pass the horn the Hip IP is located on this centreline 53mm inside the horn IP. Figure 7.18 shows the location of the horn intersection point, the centreline along the horizontal top chord of a truncated truss, and the location of the hip IP.

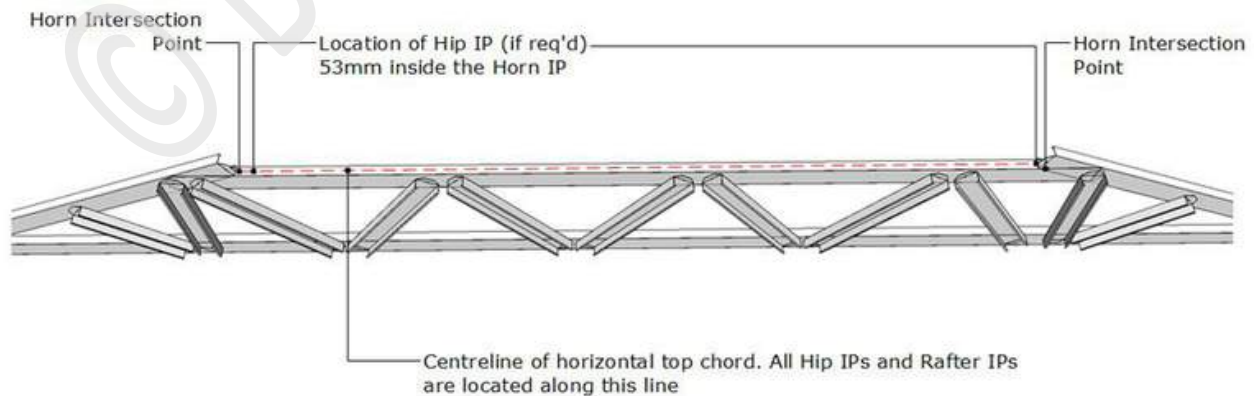

Not all hip rafters pass the horns on every truncated truss. Truss hips only cross one truncated truss, Veed hips cross the first two truncated trusses, and Boxed Hips cross all truncated trusses. Figures 7.18 and 7.19 show the location of the Rafter IP relative to the Horn IP and the Hip IP. The Rafter IP is the location on the truncated truss horizontal top chord where a common rafter passes over the horizontal top chord.

The same process is followed with 2 ply trusses and both trusses will have Horn IPs, Hip IPs (if required) and Rafter IPs, and dimple holes will be punched in both the horizontal top chord of the truss as well as the rafters.

The distance of the Hip IP and the Rafter IP from the Horn IP along the truncated truss horizontal top chord is as follows:

Hip IP from Horn IP	Rafter IP with Horn IP	Rafter IP from Horn IP when there is no Hip rafter
53mm	148mm	25mm

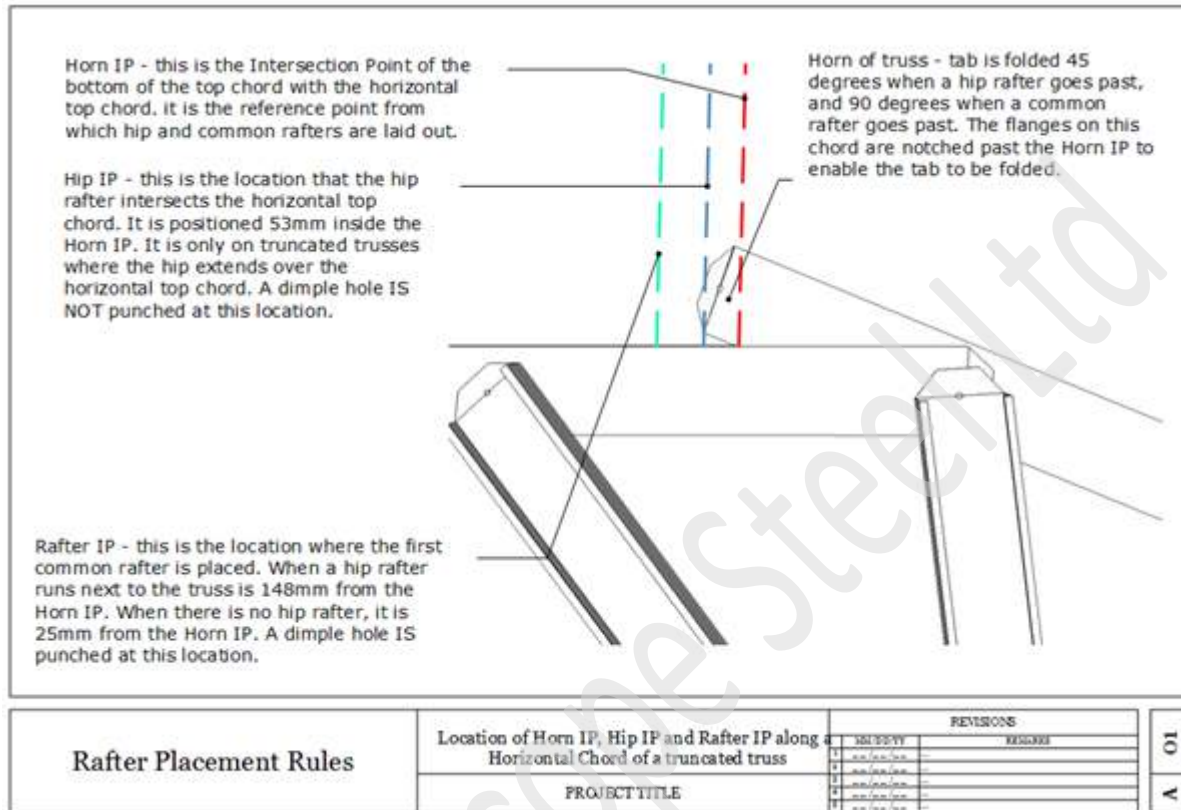

Figure 7.19

Location of Horn IP, Hip IP and Rafter IP

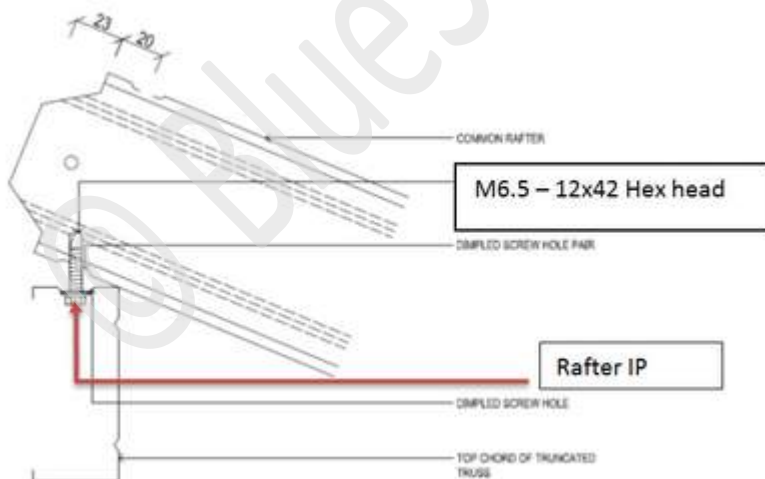

Figure 7.20 Location of Rafter IP (cross section)

7.4.4.1 Truncated truss intersection points

Hip IPs are laid out first on the top chords of truncated trusses indicated in **Figure 7.21**. Boxed hip rafters require a Hip IP to be located in all trusses, A Veed Hip rafter requires a Hip IP to be placed in the first two truncated trusses closest to the eave, while a Truss Hip only requires a Hip IP to be placed in the first truncated truss.

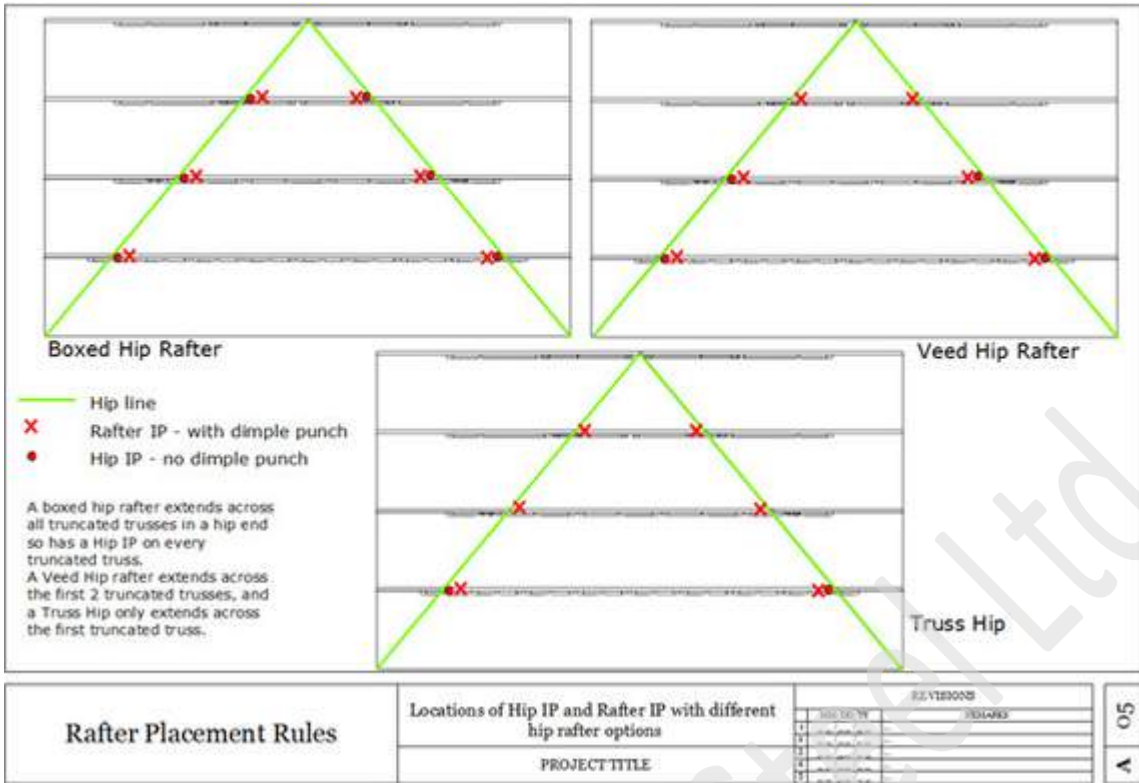

Figure 7.21 Locations of Hip IP and Rafter IP with different hip rafter options

Once the Hip IPs and rafter IPs are placed next to the horn IPs, the remainder of the rafter IPs are marked on the truncated truss top chords as shown in Figure 7.22. These are in line with the Rafter IPs on the hip line. A common rafter is placed between the 2 innermost common rafters when the spacing between those rafters exceeds the maximum truss spacing.

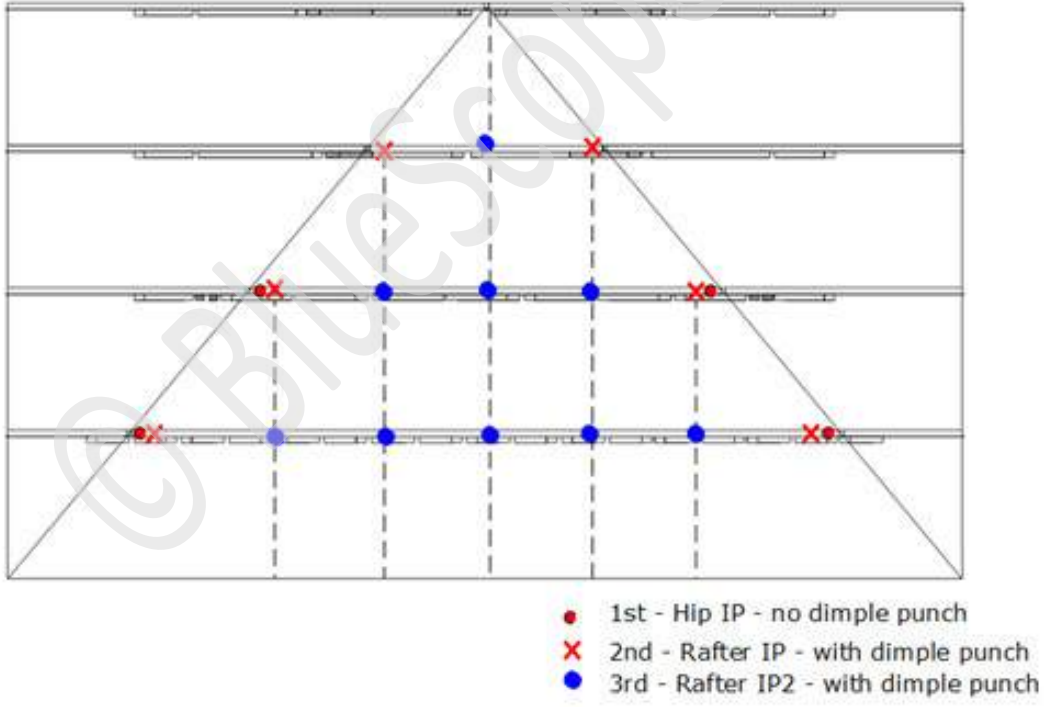

Figure 7.22 Location of additional rafter IPs (indicated as IP2)

The sequence for laying out Intersection Points are the Hip IP first, the Rafter IP second, and the Rafter IP2 last

ed as IP2)

7.4.5 Hip Rafter Construction

There are three hip rafter types that can be used with any type of hip end construction:

- boxed hip rafter
- veed hip rafter
- hip truss rafter.

Below is a summary of the details to use to fix hip rafters:

Connection type	Non-Cyclonic tile sheet	Cyclonic sheet
Hip rafter to wall – boxed hip	7.23 - 7.25, 7.50	
Hip rafter to wall – Veed rafter	7.27	7.26
Hip rafter to truncated truss – boxed hip	7.26	
Hip rafter to truncated truss – Veed rafter	7.43	7.27
Creeper/Common rafter to top plate	7.46 - 7.48	7.48 and 7.49
Creeper/Common rafter to truncated truss top chord	7.42 - 7.44	7.45

7.4.5.1 Boxed Hip Rafters

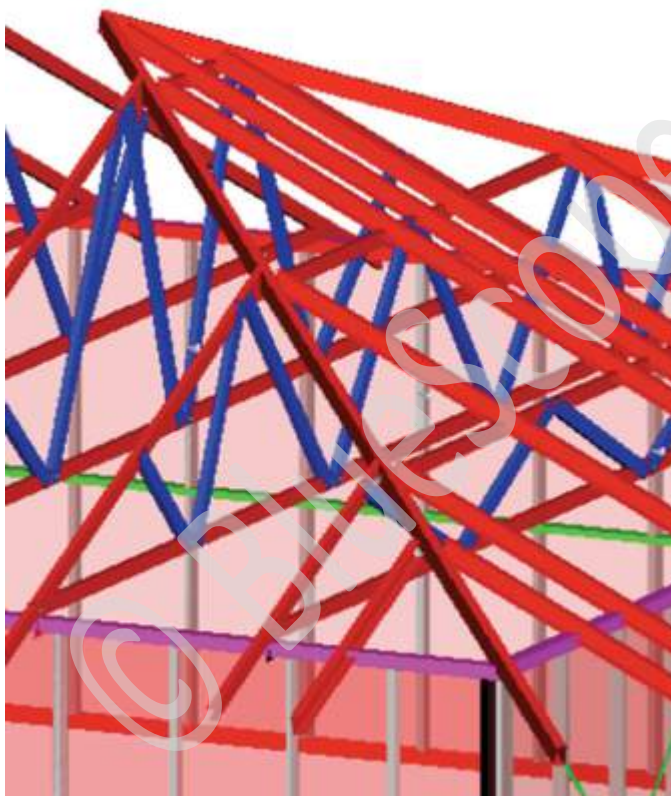

Boxed hip rafters are made from two boxed sections of the same section used for the common rafters.

Boxed hip rafters extend along the entire hip line of the roof from the eave line to the apex point of the hip allowing a 50mm gap between the two to allow them to fit together, as well as to enable a crown rafter to fit in between if one is required.

A 20mm gap is left between the boxed hip rafters at the apex to enable some manual adjustment on site to get the boxed hip rafters to fit. They can be stabilised on site by using an angle or a short piece of stud or plate to join together. Tie down connections for boxed hip rafters are shown below.

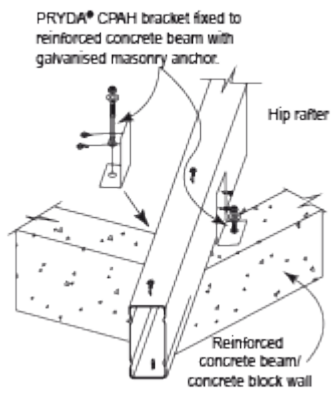

Figure 7.23 Pryda CPAH bracket

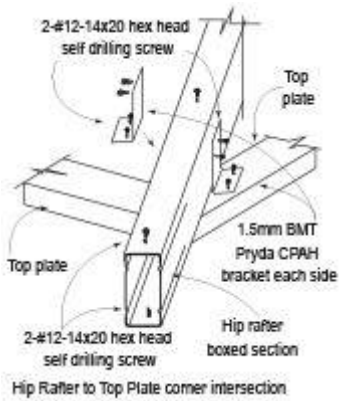

Figure 7.24 Hip rafter to top plate corner intersection

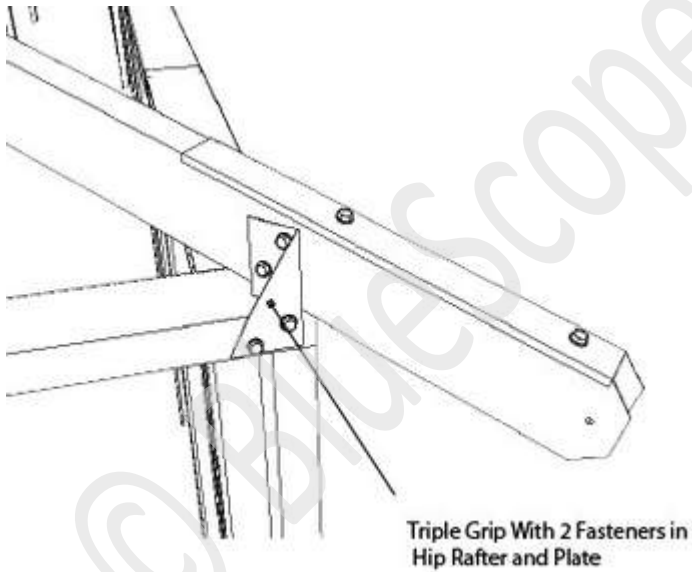

Figure 7.25 Hip rafter tie down using Triple grips for boxed member option

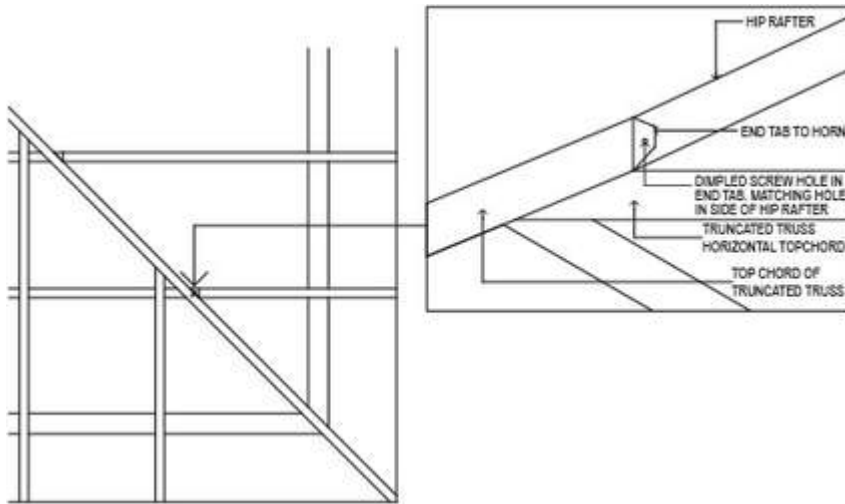

Figure 7.26 Boxed hip rafter

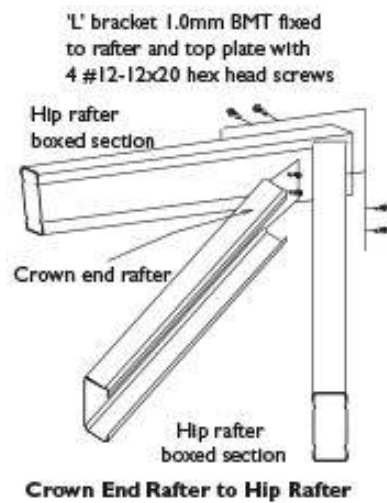

Figure 7.27 Crown end rafter to hip rafter

7.4.5.2 Veed Hip Rafter



Veed hip rafters are standard components that run from the second truncated truss to the edge of the roof. They are one of the most common forms of hip rafters used and need the least amount of material, although there is some time required for assembly. They sit on the corner of external walls and are not suitable when the pitching point extends beyond the external walls.

Veed hip rafters are available in various standard lengths, and as left and right sections to facilitate nesting against the horns of

truncated trusses. The position of the Veed hip rafter relative to the truss horn and common rafter is shown in **Figure 7.28**. The Veed plate hip rafter is manually adjusted along the hip line until it is in the correct position and the eave is correct. The creepers may be adjusted by folding in and out until they are in the correct location, and then fixed in place with a second fastener.

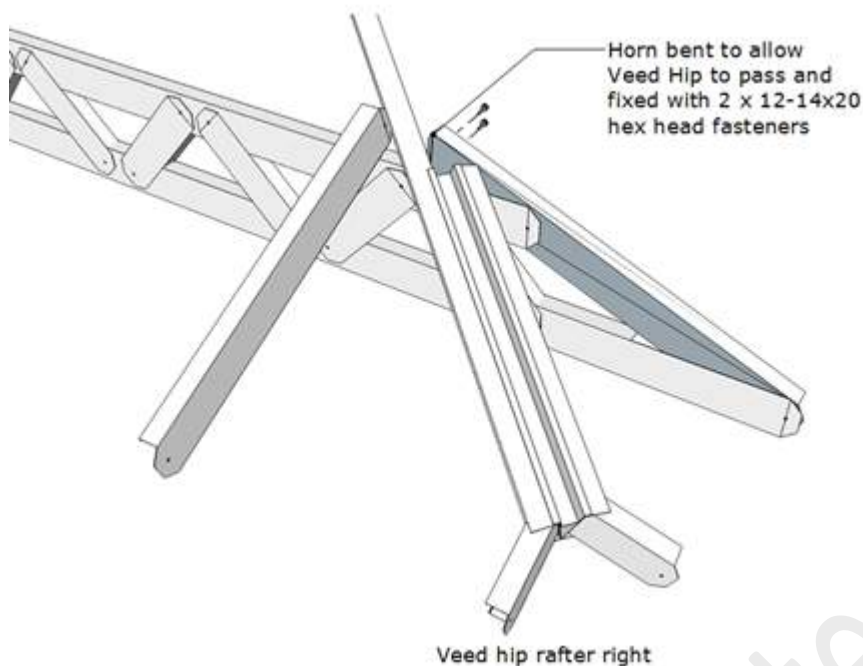

Figure 7.28 Installation of Veed hip rafter relative to horn and common rafter

Creeper rafters, if required, are pre-attached to the Veed plate hip rafter and support the fascia. There is a left and a right side with the longer rafter aligned with the bent notch on the horn of the truncated truss as shown in **Figure 7.29**. The Veed hip rafters are kept at a V section by running a Topspan 22 batten between the two chords, and the creeper rafters are pre-attached to the assembly.

The bottom flange of the longer veed hip plate section needs to be manually trimmed on site in order to fit into the truncated truss and not be obstructed by the horn on the truncated truss

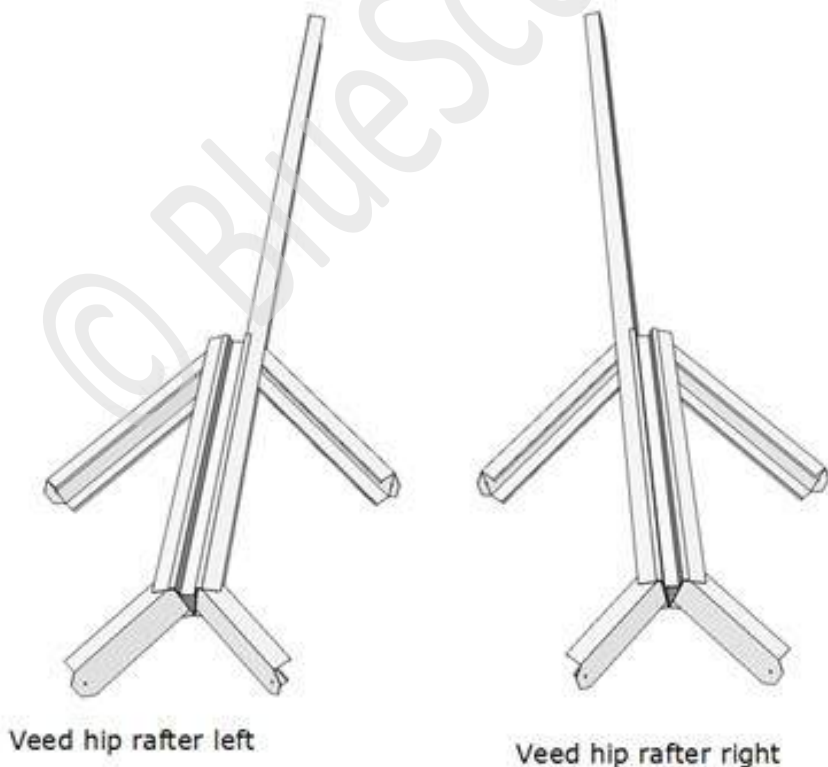

Figure 7.29 Veed Hip rafter - Left & Right

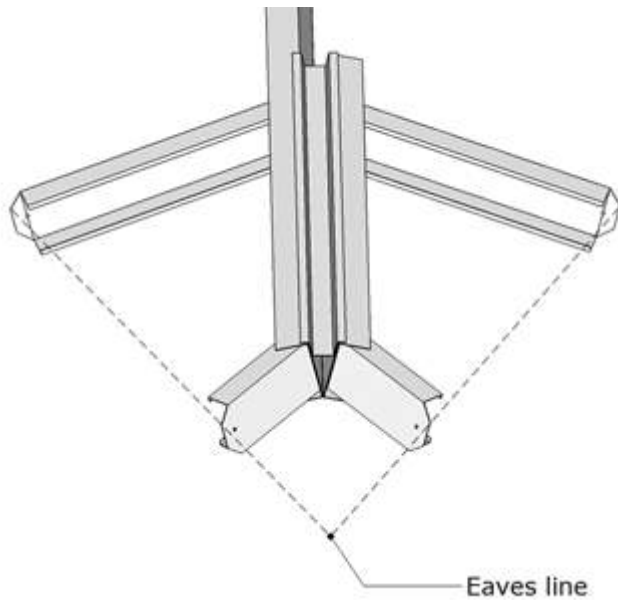

Figure 7.30 Veed Hip rafter relative to eaves line

In wind regions N1 – N3 and with overhangs of less than 200mm Veed hip rafters are fixed to the top plate using 2 x 12-14x20 hex head fasteners fastened through to the top plate as shown in **Figure 7.31**. In all other wind areas Veed hip rafters are tied down to truncated trusses and to wall frames using 25 x 1mm strap fixed with 2 x

fasteners at each of the strap as shown in **Figure 7.32**.

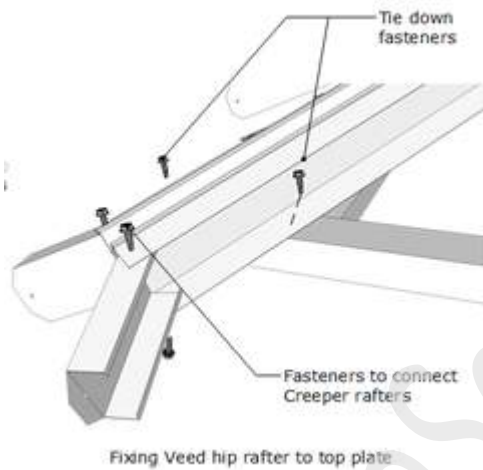

Figure 7.31 Fixing Veed hip rafter to top plate in low uplift locations

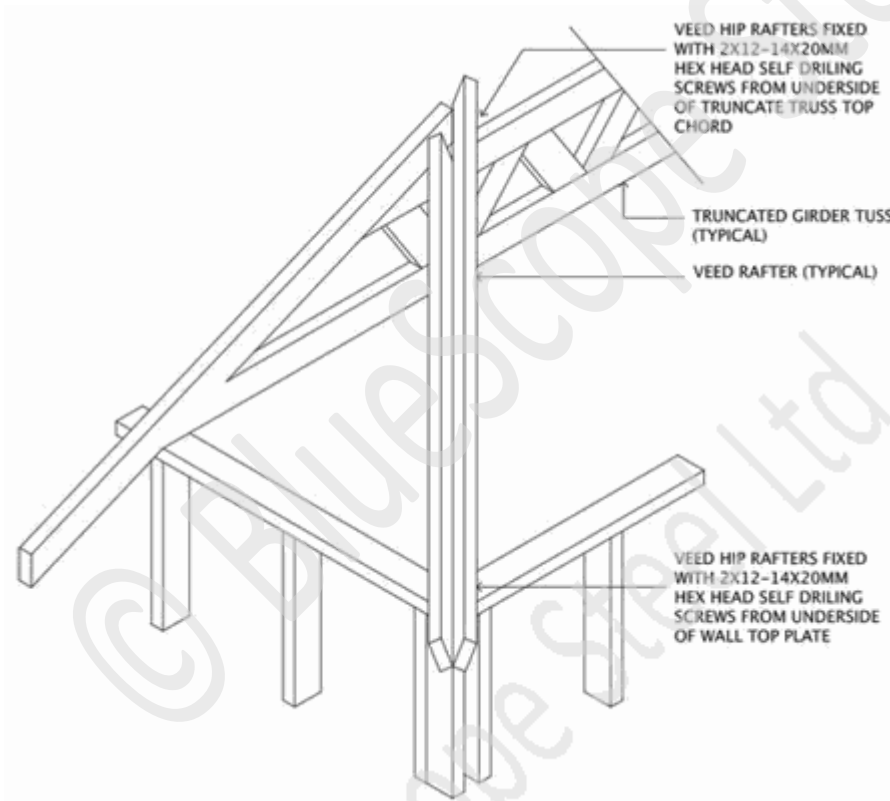
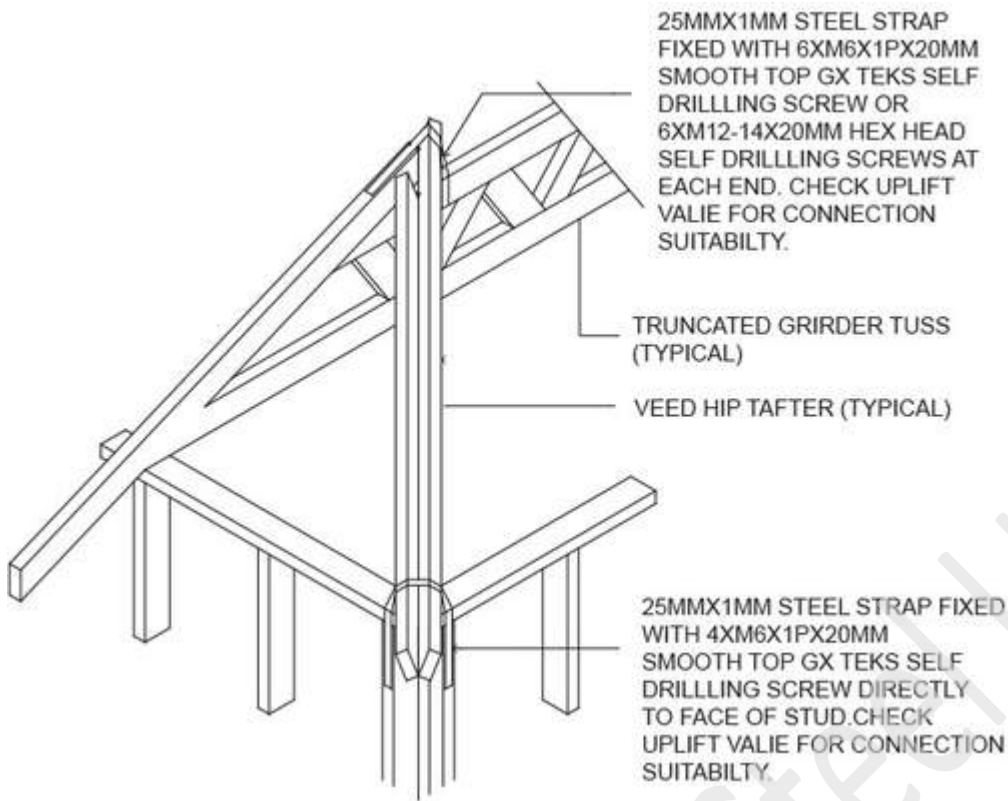

Figure 7.32. Tying down Veed hip rafters in high wind areas (left) and Veed common rafter hip (right)

Figure 7.33 Veed hip rafter to wall and truncated truss – cyclonic

Figure 7.34 Veed hip rafter to wall and truncated truss – non-cyclonic



Figure 7.35 Veed hip rafter connecting to first station truncated truss (note: bottom flange of vee hip plate notched)

Figure 7.36 Fixing Veed Hip rafter to top plate

7.4.5.3 Hip Truss

Hip trusses are flush trusses that run along the hip line from the eave to the first truncated truss for Type 1 and Type 1A hip ends, and to the truncated truss for a Type 2 Hip End. Hip trusses are the only option when the pitching point is extended past the external walls. Hip trusses are made from the same sections as the default selections made for the roof trusses.

Figure 7.38 Hip truss on a Type 1 or Type 1A Hip End

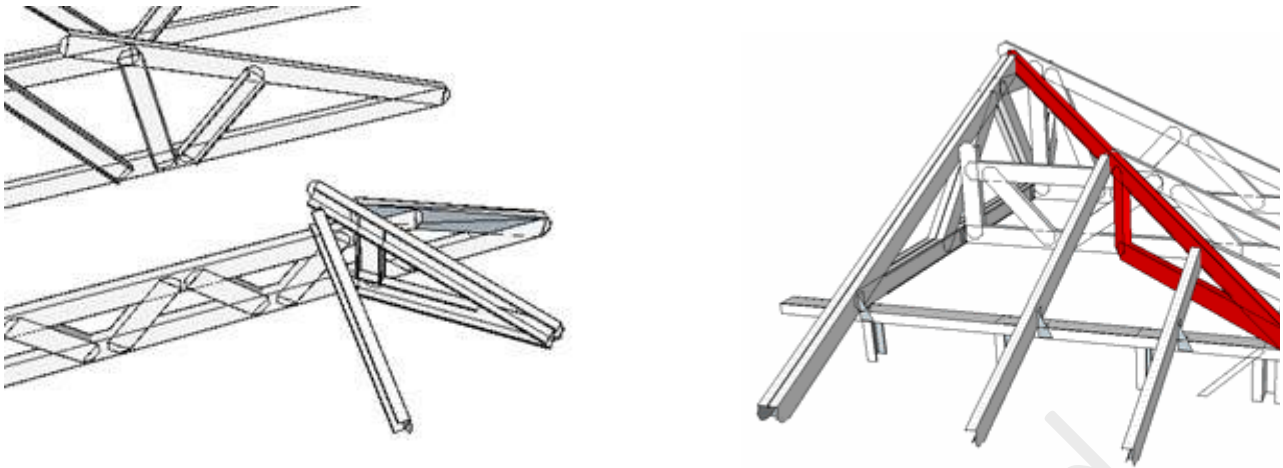

Figure 7.37 Hip truss on Type 2 Hip End

For a Type 2 Hip end the vertical chord on the hip truss stops at the first truncated truss, however it extends up to the girder truss. The creeper rafters are attached to the face of the of the hip truss.

The half trusses are all flush truss to allow for easy fixing onto the first truncated truss, and are identical to the primary half trusses used in a radial roof. The top chord extends past the vertical member by 100mm as defined in **Figure 7.39**.

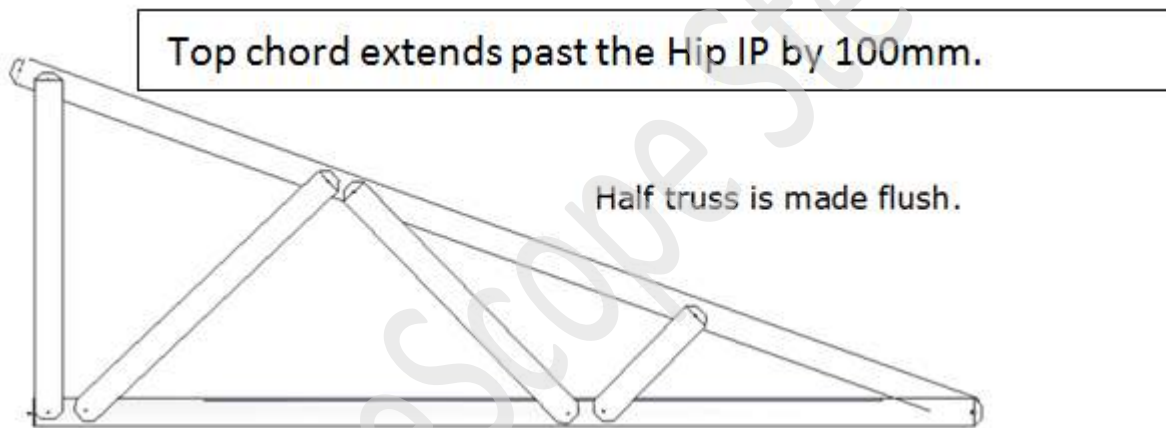
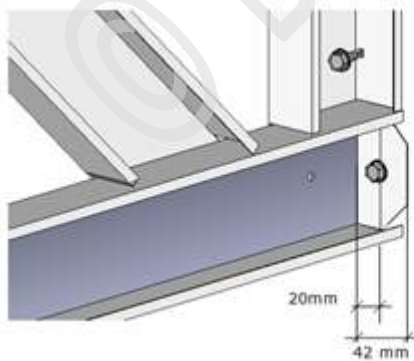

Figure 7.39 Hip truss

ss

The bottom chord has a tab extending 40mm past the vertical chord. Both the top and bottom flanges are notched to allow this to happen. This is manually bent 45 degrees as demonstrated in **Figure 7.40**. The half truss is fixed with 2 x 12-14x20 hex head fasteners through both the top chord and the bottom chord into the truncated truss.



The 6mm hole at the end of the bottom chord is 20mm past the outside face of the vertical chord. This means the bottom chord extends past the vertical chord by 42mm. The top and bottom flange of the bottom chord is notched from the face of the vertical chord.

Figure 7.40 Connection between Hip truss and bottom chord of truncated truss

The top chord of the hip truss extends past the hip IP by 100mm. The horn on the truncated truss is bent 45 degrees for the hip rafter to fix to. The toes on the hip truss face towards the center of roof. Details are shown in **Figure 7.41**.

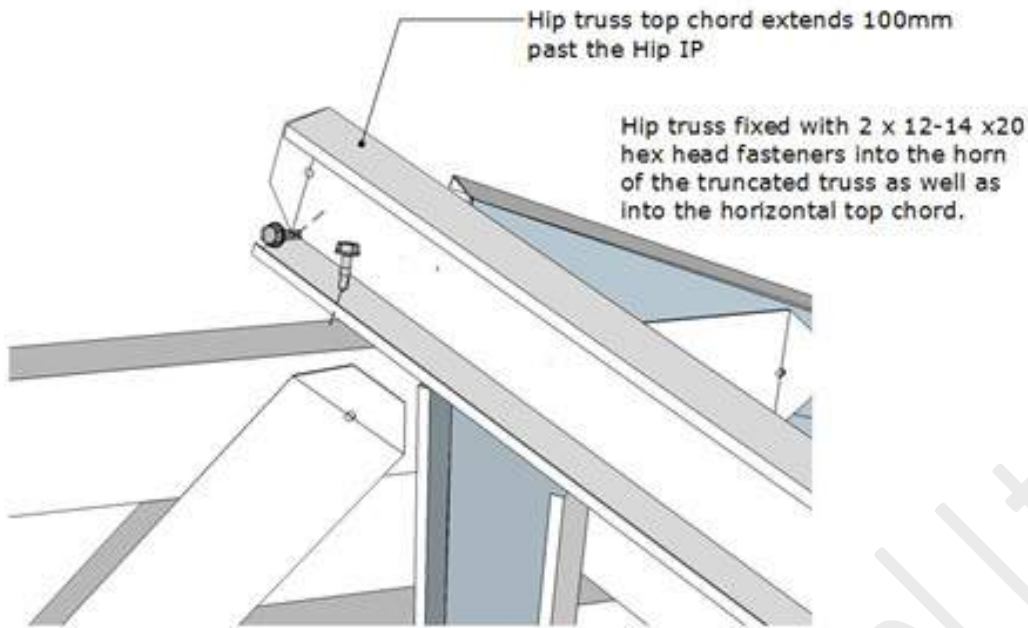

Toes on the hip truss face towards the center of the roof.
(Note: rafter not shown for clarity)

Figure 7.41 Top chord of hip truss

Tie down connections for trussed hips shall be the same as normal trusses. A 25 x 1mm

overstrap can be selected and used similar to a Veed hip rafter as shown in **Figure 7.32**.

7.4.6 Common Rafters

Common Rafters run perpendicular to trusses to the eave of the building. Toes shall face towards the centre of the roof as shown in **Figure 7.42**. There are a variety of tie down options both to the truncated truss top chords and the wall.

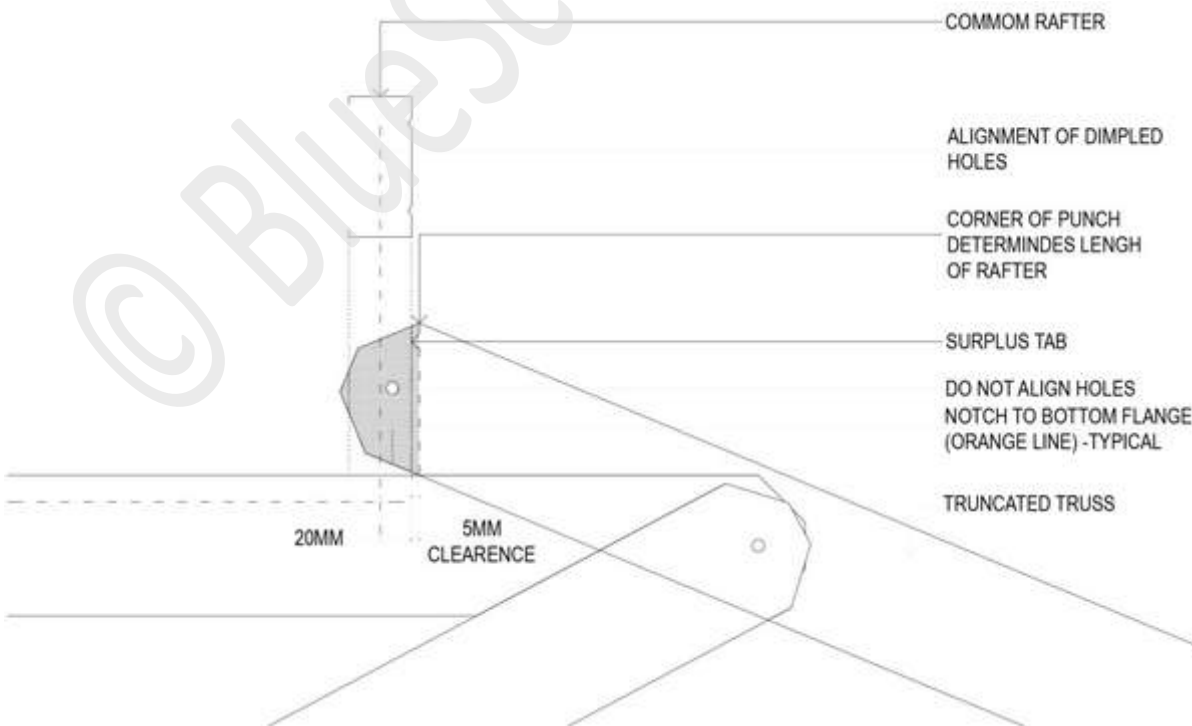

Figure 7.42 Common rafter to truncated truss at hip

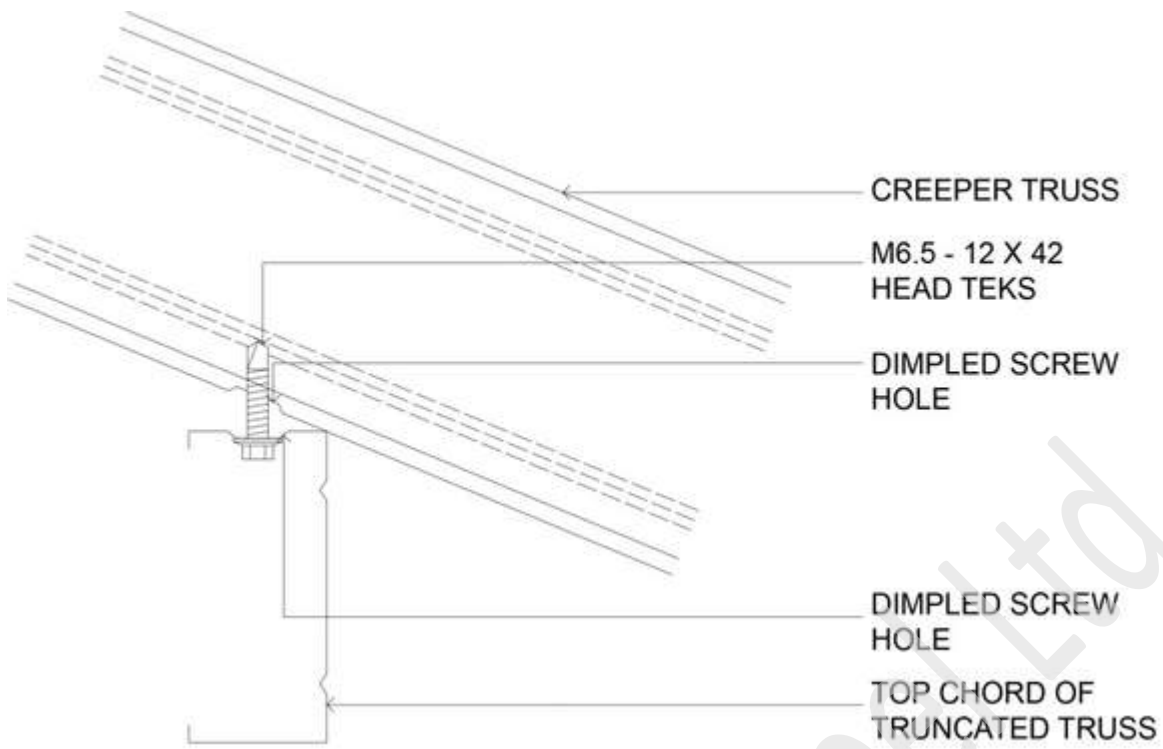

Figure 7.43 Common rafter to truncated truss

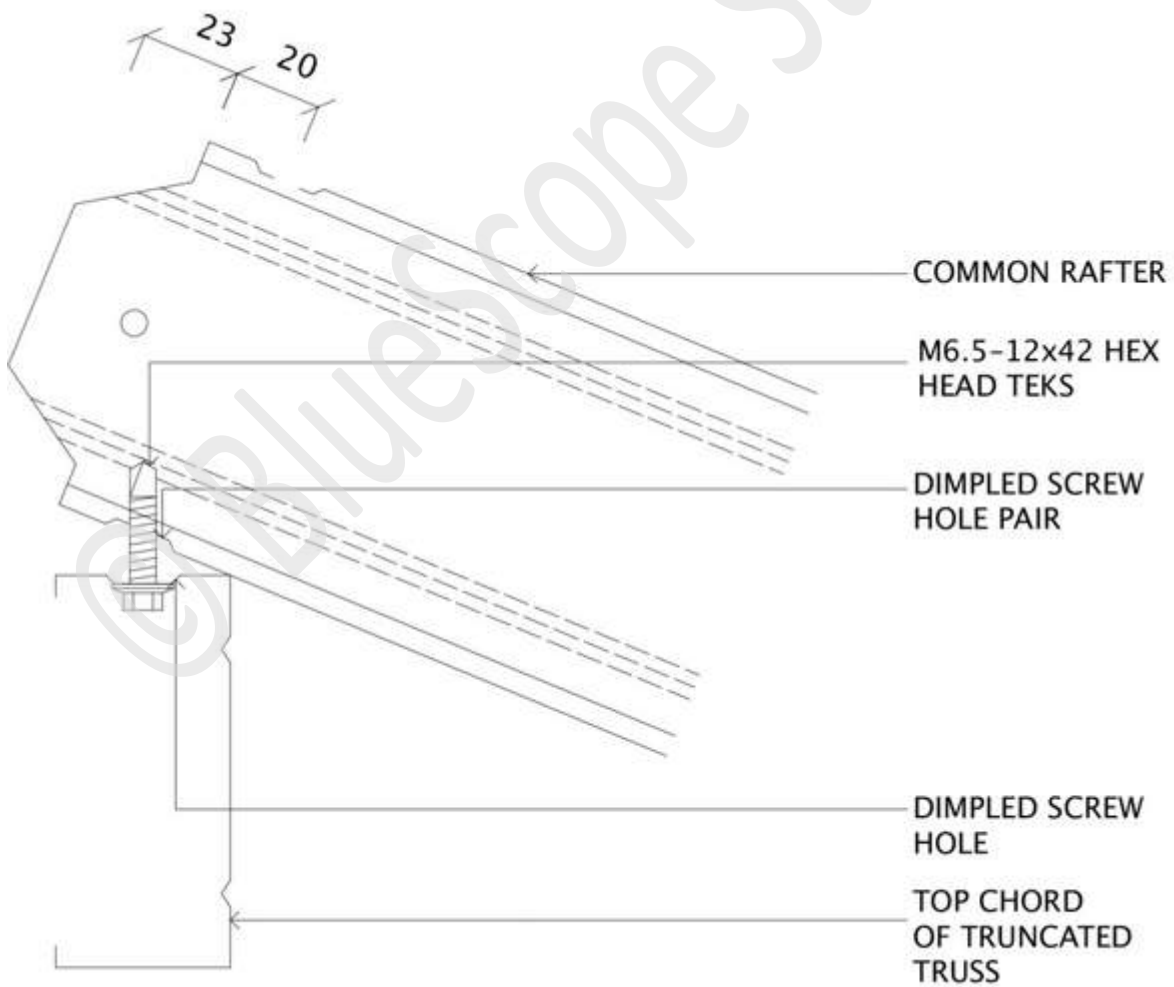

Figure 7.44 Common rafter to truncated top chord end

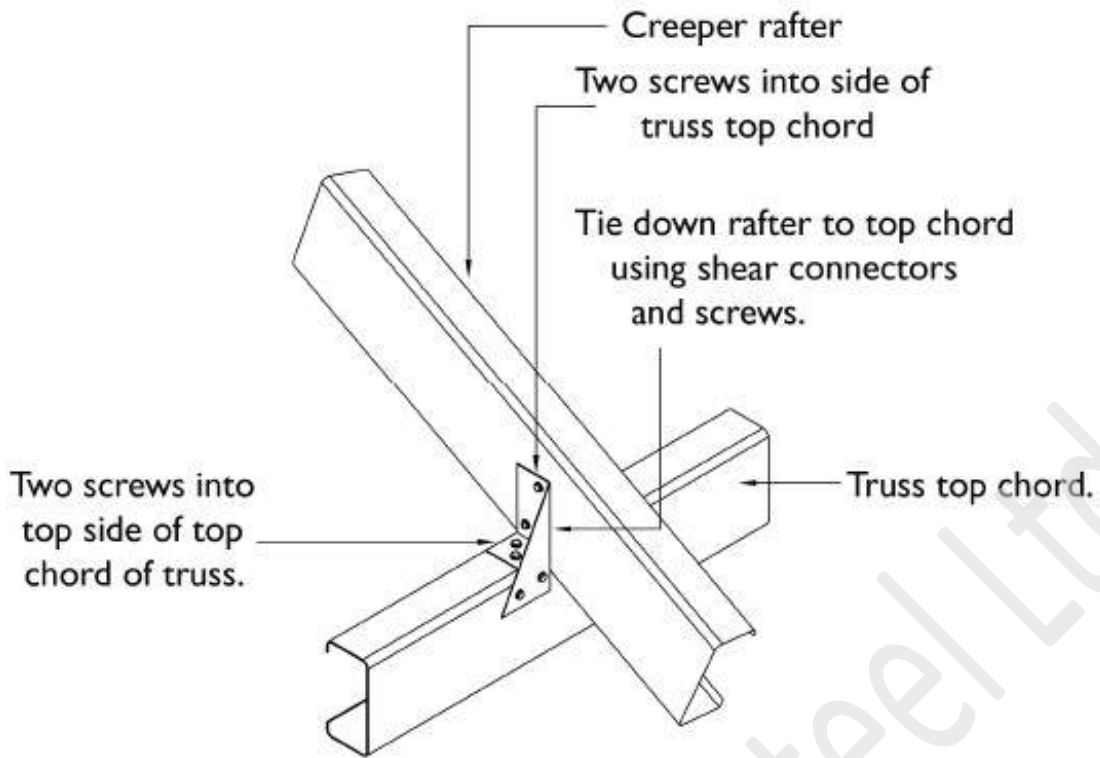

Figure 7.45 Common Rafter to truss top chord using shear connectors. Trip-L-grip shown but Multi-grip or angle may also be used

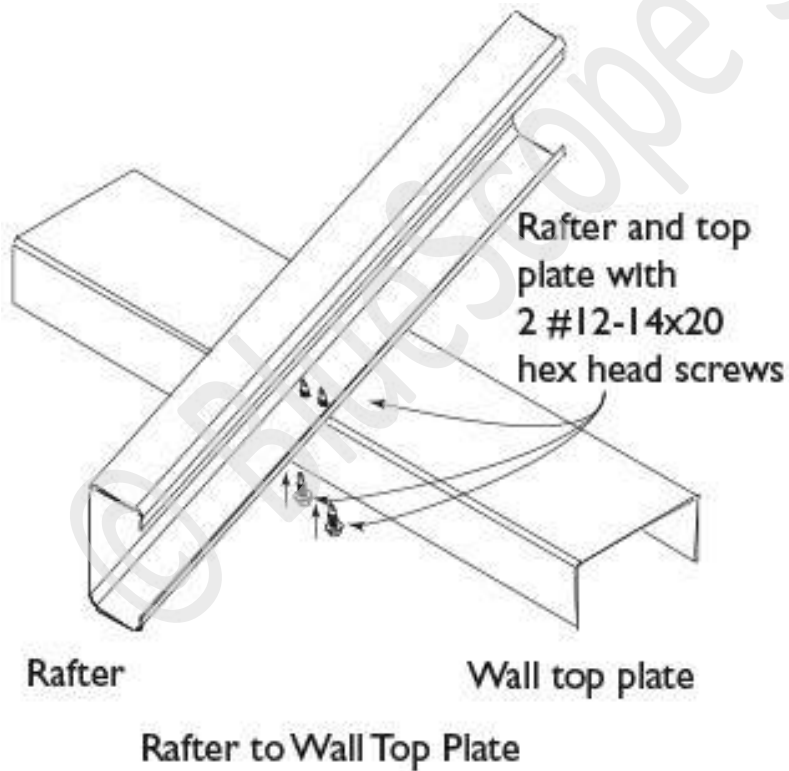

Figure 7.46 Common Rafter/creeper rafter to wall top plate using screws

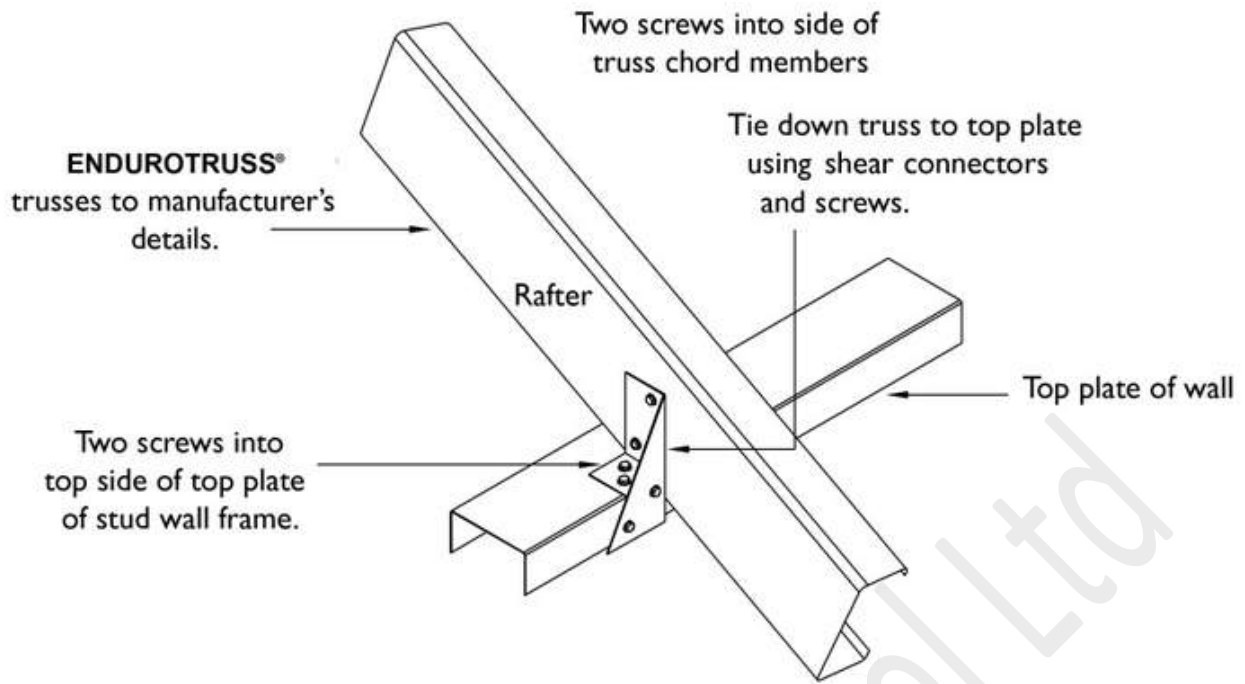

Figure 7.47 Rafter to wall top plate using Pryda® Triple-Grip shear connector

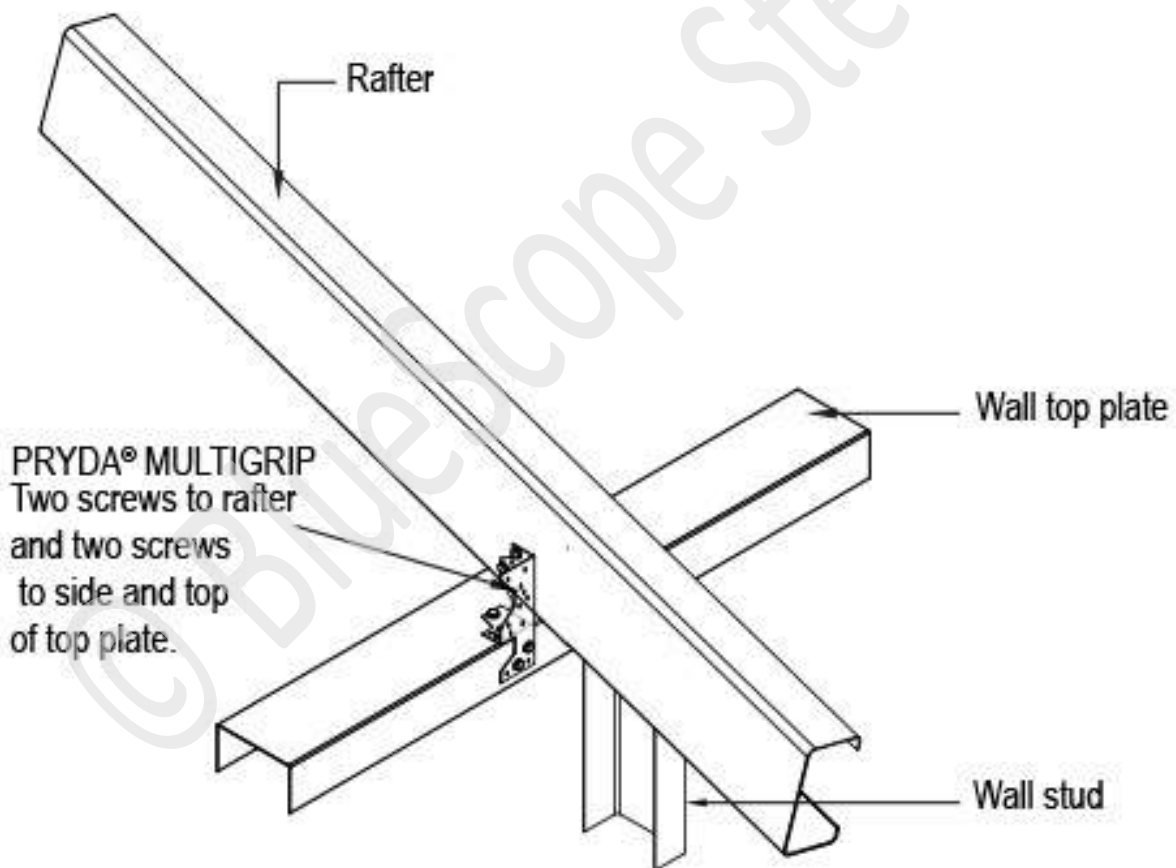

Figure 7.48 Rafter to wall top plate using Pryda® Multi-Grip

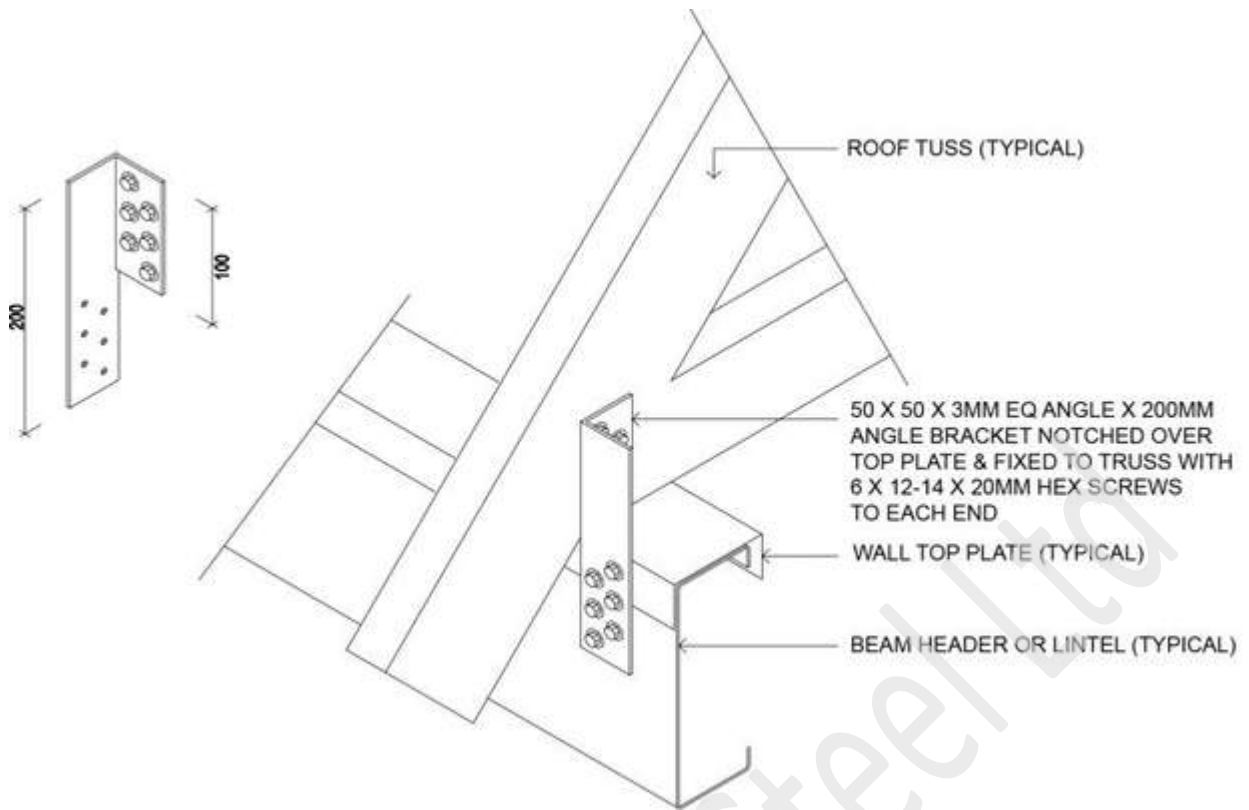

Figure 7.49 Common rafter top plate

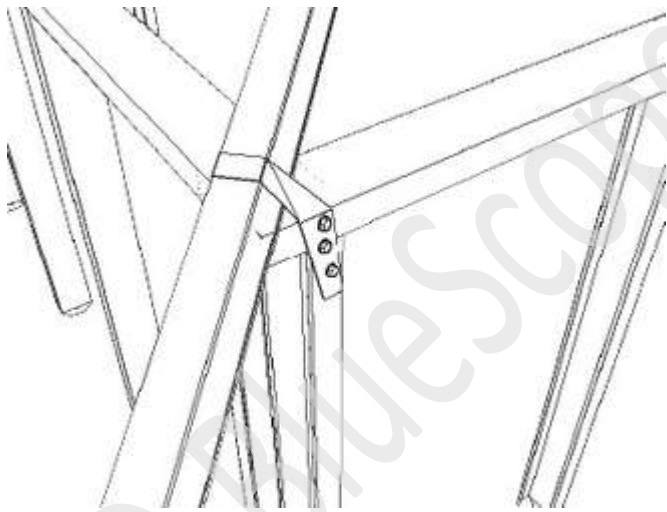

Figure 7.50 Hip rafter tie down using 1.2 x 30mm strap over hip rafter attached with 3x12-14x20 hex head fasteners

7.4.6.1 Common Rafters on Dutch Gables

Common rafters connect to a flush truss with the toes facing away from the hip end, and a horizontal rail back-to-back with the truss chords and webs. End rafter IPs are placed 43mm away from the intersection point of the underside of the top chord and the horizontal rail towards the center of the truss. Additional intermediate rafter IPs are placed along the horizontal rail at no more than the truss spacing at even spacings. This is demonstrated in **Figure 7.51**.

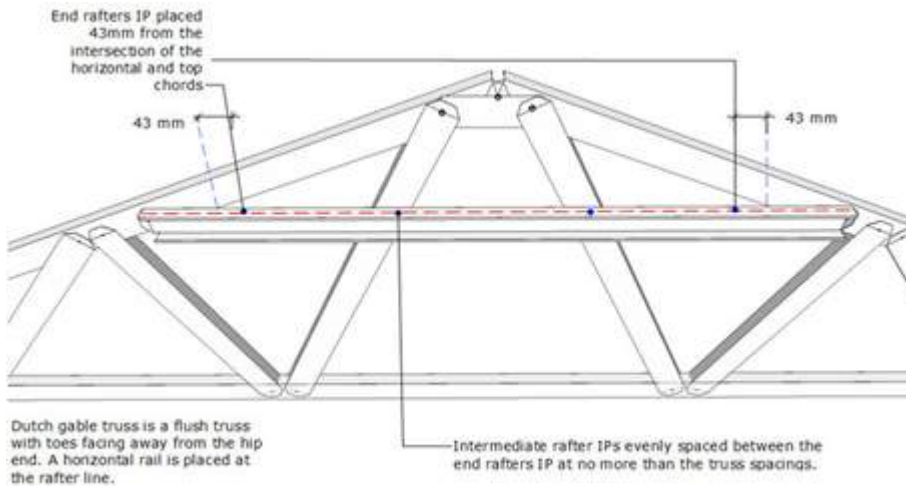

Figure 7.51 Location of rafter IPs on a Dutch Gable truss rail

Common rafters fit onto the horizontal rail following the cross section shown in **Figure 7.44**.

If the V notch on the rafter clashes with either the webs or chords it would be manually trimmed or bent on site so it can fit.

7.4.7 Crown Rafters

A Crown Rafter is positioned at the centre of a standard hip face running from the intersection point of the hip lines to the outside edge of the eave block.

A Crown Rafter Tie is an additional horizontal piece spanning from the top of the crown rafter (intersecting hip lines) to the first standard truss. The minimum distance from the top of the crown rafter to first standard truss should be 150mm for the horizontal extension piece to be implemented.

The length of this crown rafter tie will be 40mm past the Top Chord of the adjacent standard truss.

The end of the Crown Rafter tie will have flange and lip notches (like the bent tab at bottom of studs). This then gives flexibility on site to be manually bent and a screw manually added through the web of the rafter extension into the top chord of the adjacent truss.

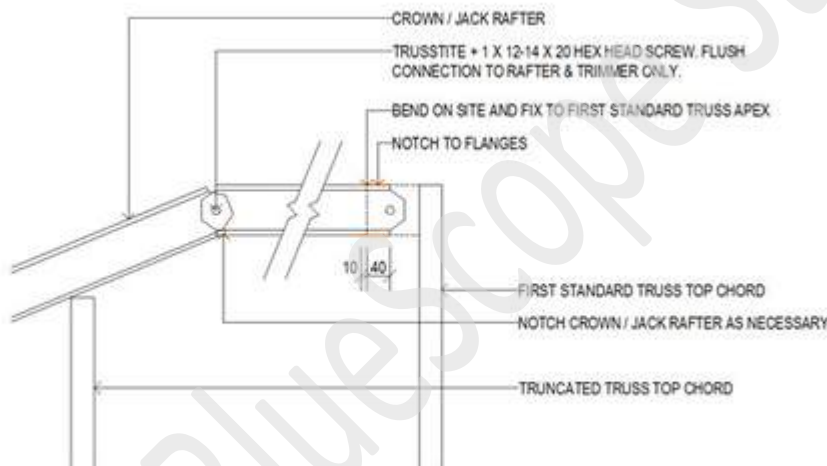

Figure 7.52 Crown Rafter Tie Details

7.4.8 Creeper Rafters

Creeper rafters are required where the spacing between the point between the end of the hip rafter and either the first truncated truss or the common rafter exceeds the maximum truss spacing. They are only required for a Boxed Hip or a Hip Truss, as Veed Hip Rafters have in-built creeper rafters. Connection of creeper rafters is similar to the connection between a secondary and primary truss in a radial roof.

A creeper rafter is positioned to land on the wall at the mid-point between the hip rafter and either the first station truncated truss and/or the first common rafter. In the case of a boxed hip, a single member is added as a top chord while with a hip truss, a truss is added, and is connected at both the top and bottom chord of the hip truss.

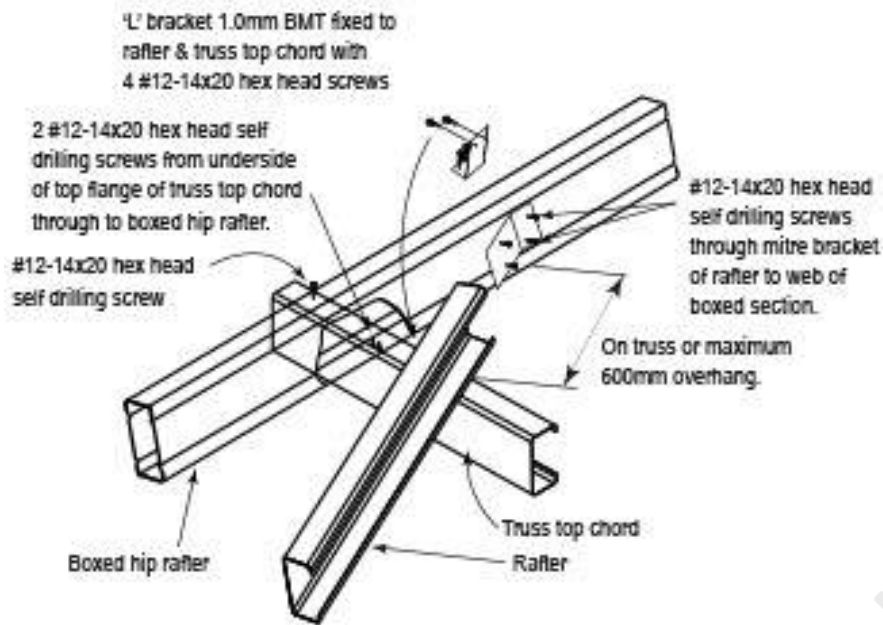

Figure 7.53 Hip/creeper rafter connection

The toes on the creeper truss/rafter face away from the boxed hip/hip truss.

Both the top and the bottom chords extend past the vertical chord by 40mm, and are notched on both flanges so they can be bent at 45 degrees and fixed to the primary truss as shown in **Figures 7.54 and 7.55**. If this tab a damaged Pryda MT15 Plate can be used.

Where the creeper truss connects to the open face of a hip truss a 200mm long boxing piece is attached to the hip truss to provide a fixing point. This 200mm long piece is cut from surplus material and factory or site installed. The centreline of the boxing piece on the top and bottom chords shall be marked on the fabricated drawing.

The end of the intermediate truss top chord extends past the primary truss by 40mm. It is notched on both flanges and is manually bent, and attached with 2 x 12-14x20 hex head fasteners.

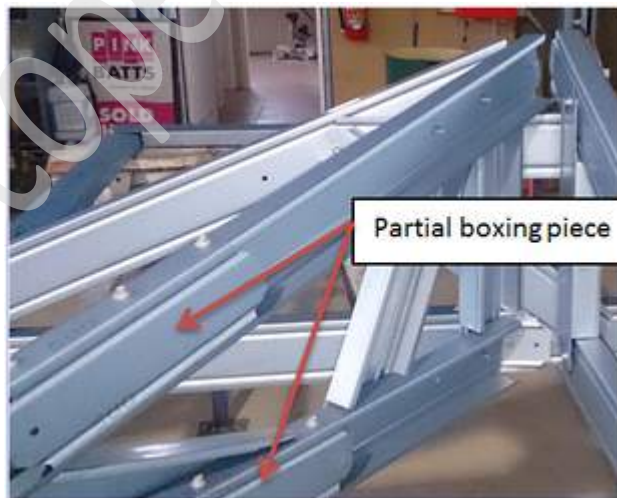
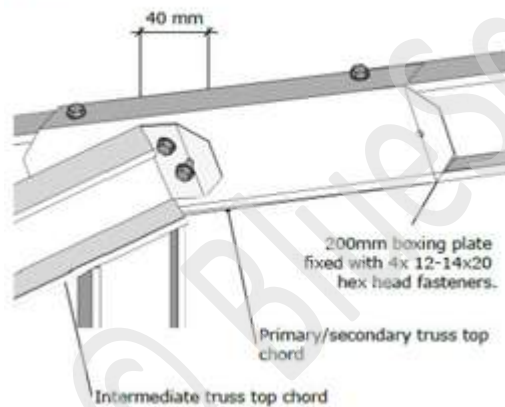

Figure 7.54 Connecting top chord or creeper to boxed hip or hip truss (hip truss shown)

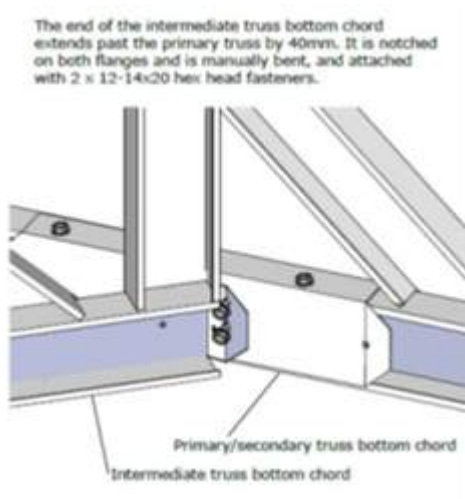

Figure 7.55 Positioning of bottom chord of creeper rafter onto a hip truss

Creeper rafters are generally built with just a single top chord however may require a vertical and horizontal chord to be inserted. This is required especially where the truss pitching point is cantilevered past the walls as the horizontal and vertical chord will ensure that the top chord follows the roof plane when the creeper rafter is installed.

The rules for construction of creeper rafters are described in the following table:

		Hip Rafter selection		
		Veed Plate	Box hip	Hip Truss
Hip end selection	Type 1	Single chord	Single chord	Single chord
	Type 1A	Single chord	Top chord, vertical chord & horizontal chord	Top chord, vertical chord & horizontal chord
	Type 2	Single chord	Top chord, vertical chord & horizontal chord	Top chord, vertical chord & horizontal chord

7.5 Dutch gable construction



Figure 7.56 Dutch gable

Dutch gables are constructed in a similar way to Type 1 hip ends. A standard A truss is provided at the nominated set-back position and is provided with a horizontal channel rail to support the rafters. Installation of truncated trusses and rafters is in accordance with the Type 1 hip end construction. The setback position is shown on the truss layout drawing shown in **Section 7.2**.

Constructing Dutch Gables

To construct a Dutch Gable:

Step 1: Study the entire set of architectural and fabrication drawings.

Step 2: Follow steps 2 to 6 of **Section 7.4.1** on Hip end construction.

Step 3: Stand the Dutch gable truss orientated with the webs of the truss facing toward the hip end wall. The rafter support rail is oriented with the toes facing away from the hip end wall. (i.e. the same as the truncated truss chords). This provides a secure fixing of the rafter to the support rail.

Step 4: Fix the truss to the heel brackets as per Hip end construction.

Step 5: Temporarily brace the truss plumb and straight.

Step 6: Install the Hip rafters as per step 8 of **Section 7.4.1** on Hip end construction fixing the rafter to the wall, truncated trusses and Dutch gable truss using the details shown.

Step 7: Install Jack rafters where shown on the truss layout in accordance with step 9 of **Section 7.4.1** on Hip end construction.

Step 8: Creeper rafters are supported by the hip rafter and the external wall. They are generally short rafters near the corner of the building. Ensure sufficient back span is provided to give the installed rafter sufficient strength. Mark the overhang length on the creeper rafters as per the jack rafters. Install the creeper rafters in the locations shown on the layout drawing fixing to the creeper rafter and the wall top plates as shown in **Figure 7.26**.

Fix creeper rafter to hip rafter as shown in **Figures 7.25** to **7.27**.

Step 9: If not factory installed, fix battens to the Dutch Gable truss Chords to suit the fixing requirements of the Dutch gable end cladding. These battens should be spaced to suit claddings and designed to suit the length and loading criteria.

Note: When all trusses are erected, install wind bracing as specified in **Section 7.9** on Roof Bracing.

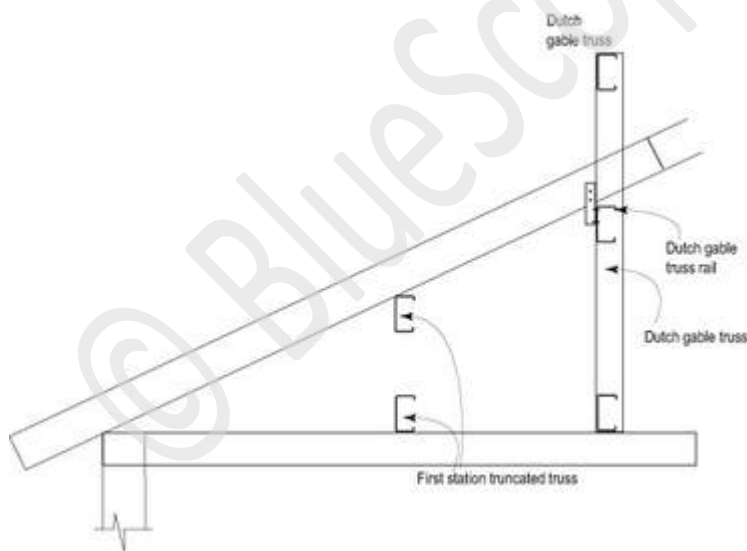

Figure 7.58 Dutch gable truss section view

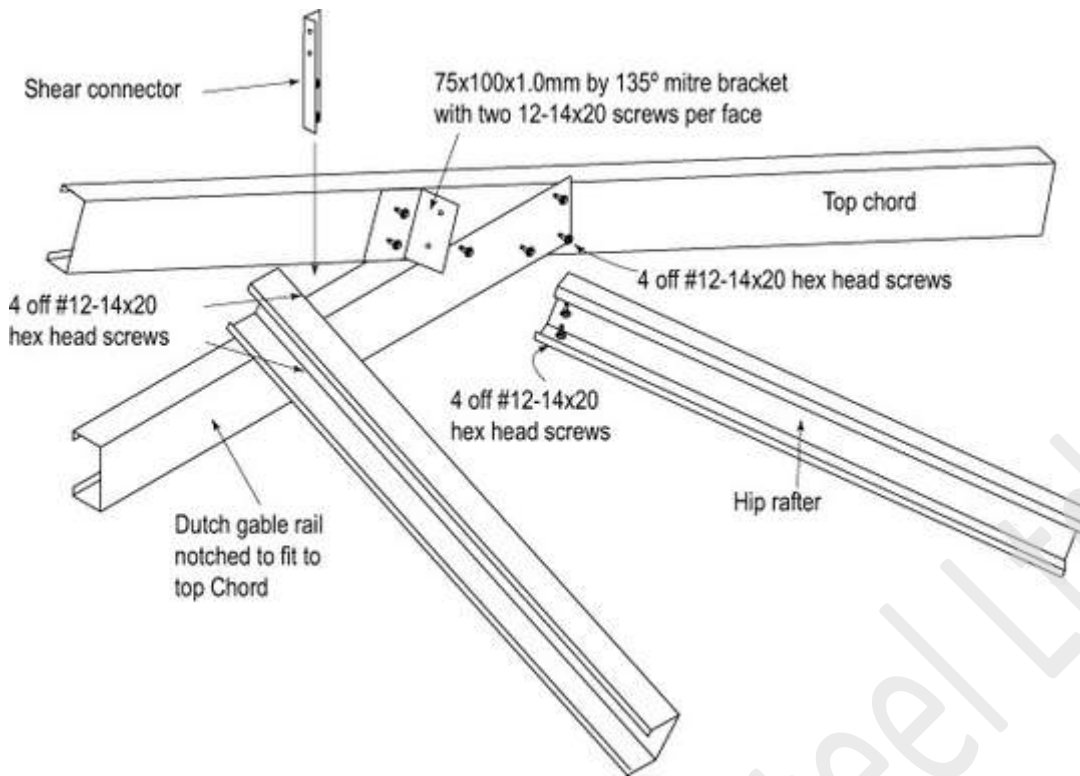

Figure 7.59 Dutch gable rail to top chord connection

7.6 Valley end construction

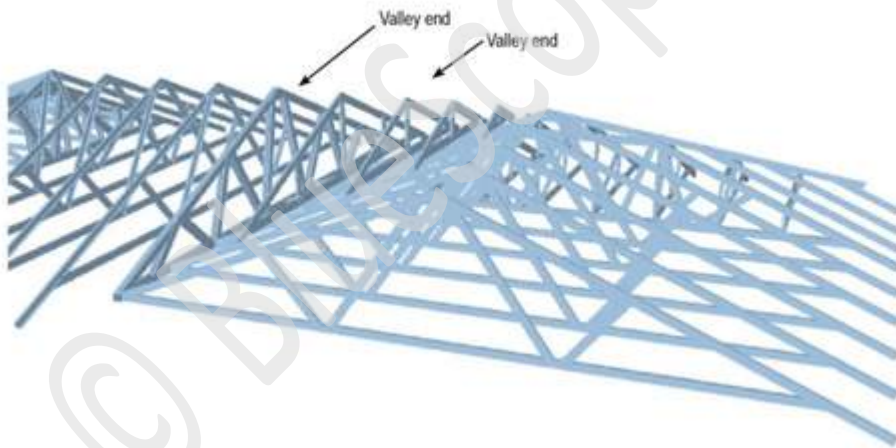

Figure 7.60 Valley end connection

Figure 7.60 shows a typical arrangement for bridge trusses supported by a girder truss. Saddle trusses are placed over the bridge trusses to infill the void and form the ridge line. This combination of bridge girder and saddle truss set is called a valley end.

Table 7.8.5 Limit State Design Loads for Pryda® TBJ45 Bracket (Bridge Truss to Girder Truss)

Top Chord	Bottom Chord	Fasteners Bracket to Girder Truss	Fasteners Bracket to Bridge Truss
0.75mm Boxed	0.75mm Boxed	8x#12-14x20	8x#12-14x20
1.0mm Boxed	1.0mm Boxed	8x#12-14x20	8x#12-14x20

7.6.1 Girder-bridge truss connection

Step 1: Study the entire set of architectural and fabrication drawings.

Step 2: Set out and mark truss position as per **Section 7.2**. Mark Bridge Truss positions on the Girder Truss bottom chord. Ensure that the bridge truss location is marked on the correct truss as specified in the girder truss fabrication sheet.

Step 3: Install fixing brackets to the wall top plates to fix girders, bridge trusses and rafters in marked positions. Attach Pryda TBJ45 brackets to Girder bottom chord web in the marked positions. Note that the bottom chords of the Girder trusses are always boxed and that the brackets are fixed to the web of the bottom chord.

Step 4: Install the first ply of the girder truss which has the Pryda TBJ45 bridge brackets installed and fix it to the hold down bracket at the heels.

Step 5: Temporarily brace the girder truss and ensure that it is plumb and straight. This can be done using batten or roof bracing material fixed to the end wall and to the top chord of the truss.

Step 6: Install the bridge trusses to the external wall and girder truss as shown in **Figure 7.64**.

Step 7: Install the second ply girder truss (if applicable) with the toes of both trusses facing each other and fix it to the brackets as shown in **Figure 7.62**. Install 1x12-14x20 Hex Head screws through EVERY service hole provided on the bottom chord to connect the two trusses together as shown in **Figure 7.64** Install 200 long plate sections with 4x12-14x20 hex- head screws to top chord near apex and midspan of top chord.

Step 8 The bridge trusses require to be trimmed at intersection of top and bottom chords. Refer to **Figure 7.61**.

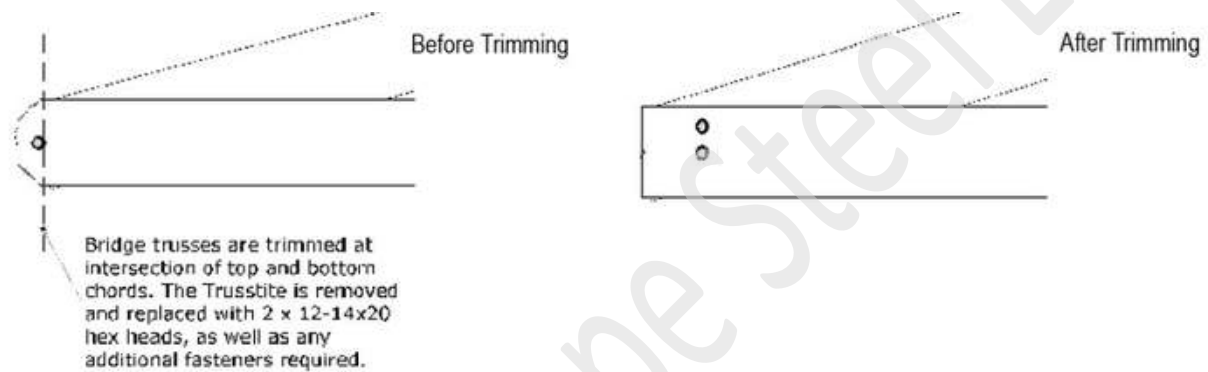

Figure 7.61

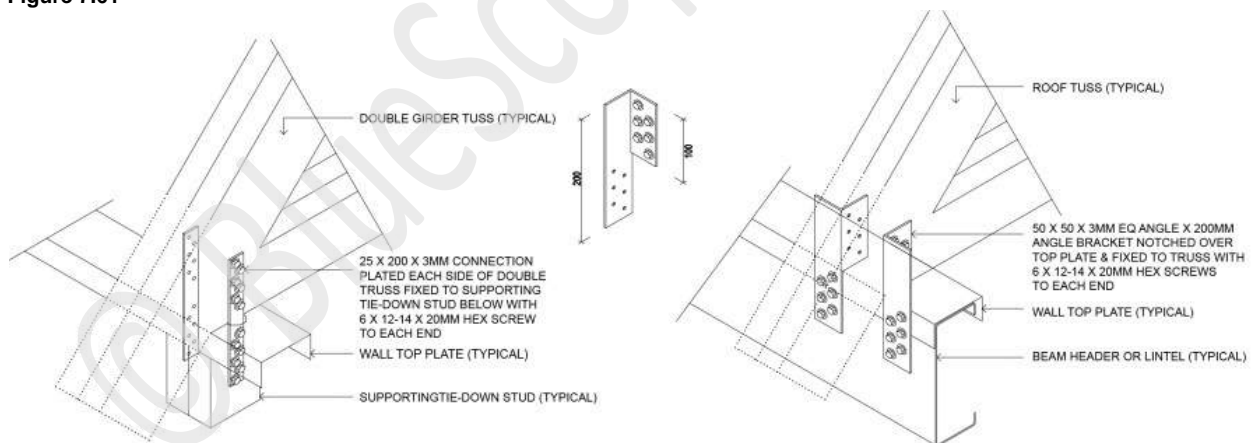

Figure 7.62 Double Girder Truss Hold down with angle and strap tie down option

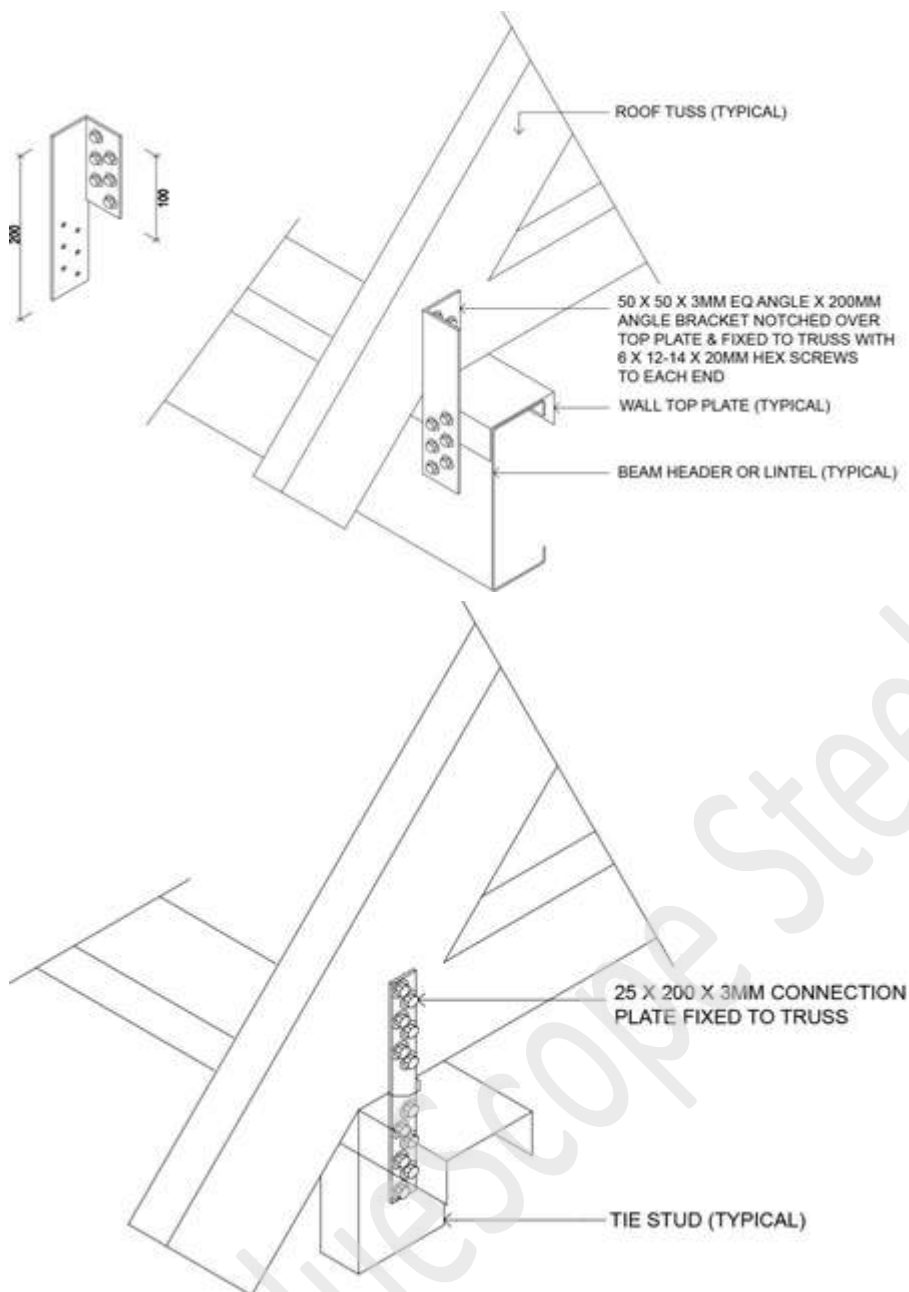

Figure 7.63 Single girder truss hold down

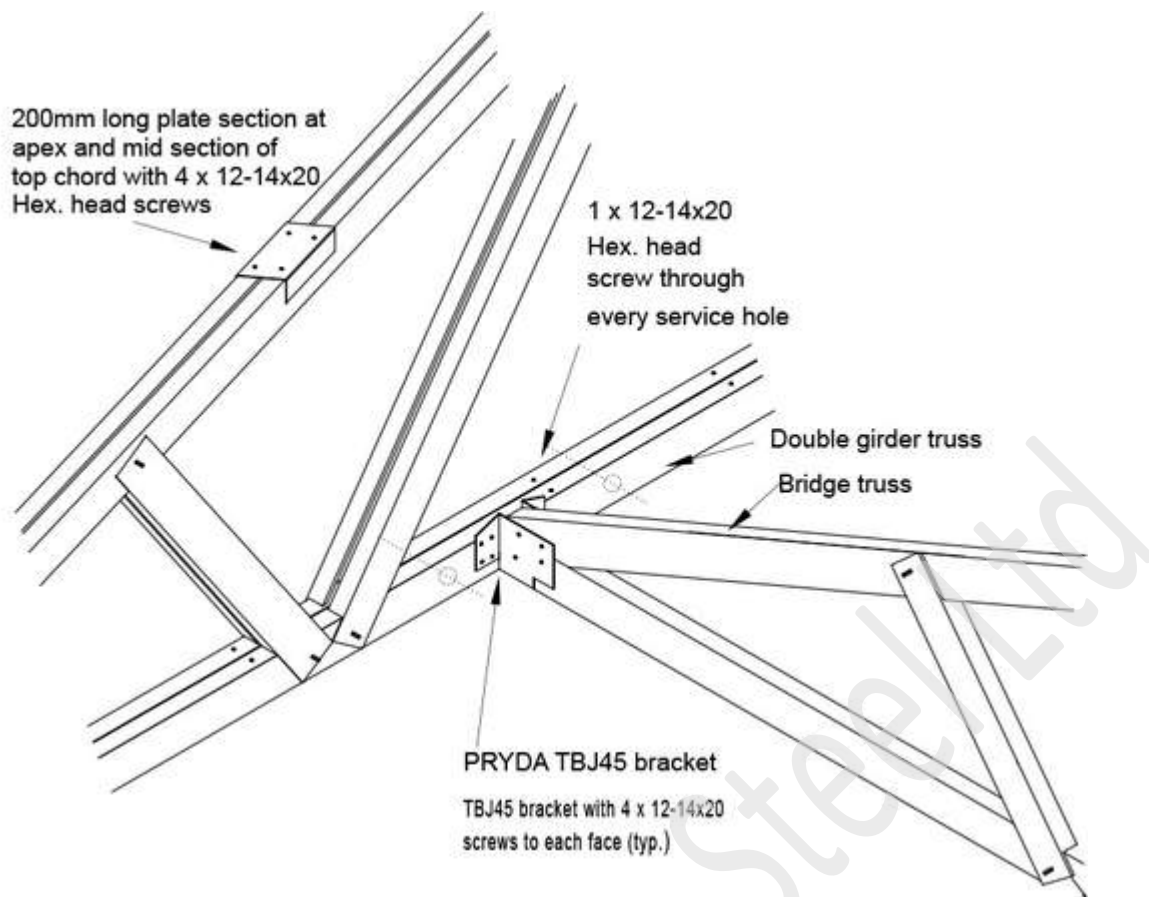

Figure 7.64 Double Girder Truss Connection

7.6.2 Saddle truss construction

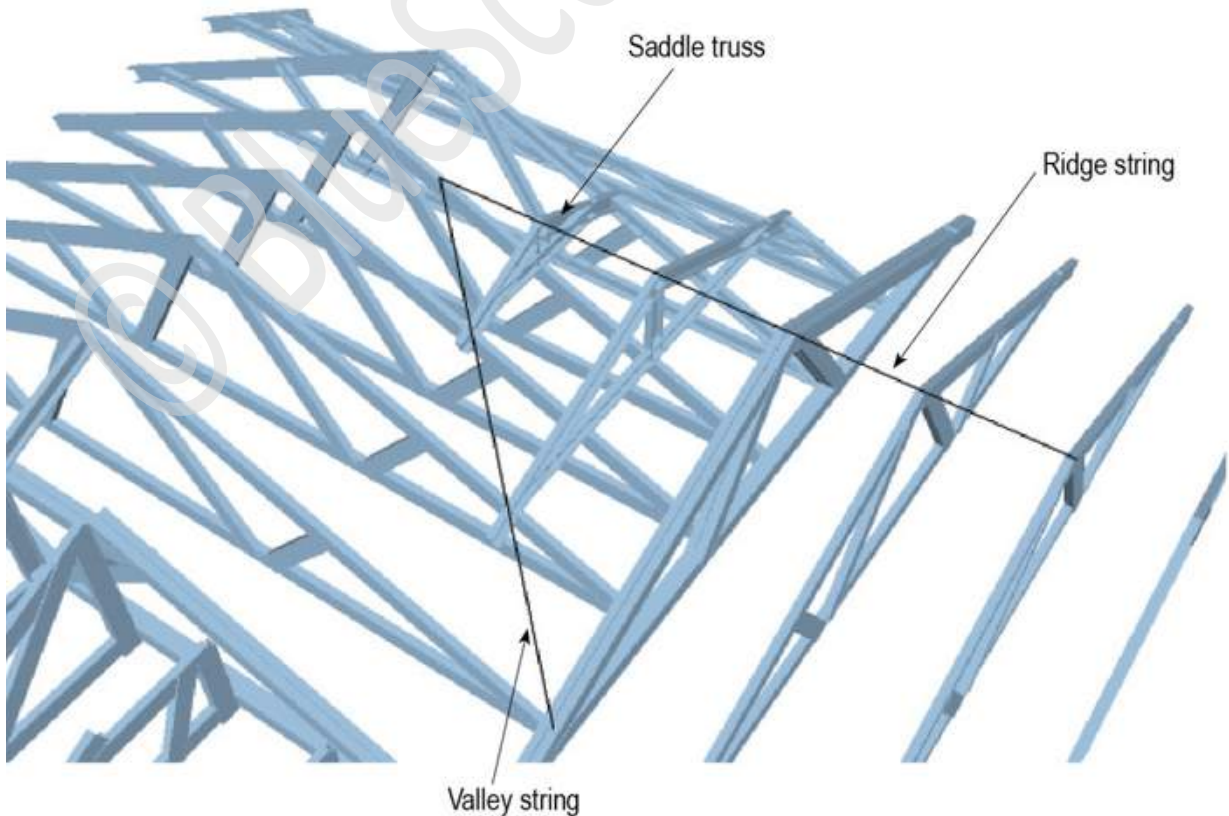

Figure 7.65 Saddle truss detail

Step 1: Study the entire set of architectural and fabrication drawings.

Step 2: Fix a string line along the ridge line of your roof and down the valley lines to aid in the positioning of saddle trusses as shown in **Figure 7.65**.

Step 3: Position the largest saddle truss keeping it parallel to the edge of the main roof. With the open face of the bottom chord facing down the slope and the webs facing up the slope, adjust the truss positions so that the long points of the foot cut line up with the valley string lines.

Step 4: When the saddle truss is standing plumb, the apex line should line up with the apex string line.

Step 5: Fix the bottom chord of the saddle trusses to the top chord of the underlying truss with an angle bracket as shown in **Figure 7.67**.

Step 6: Repeat steps 3, 4 and 5 for subsequent saddle trusses until the saddle block is complete.

Step 7: Temporarily brace the apex of the saddle trusses.

Note: The smallest saddle truss will require a trimmer to be installed below it for extra support as shown in **Figure 7.66**.

Note: When all trusses are erected, install wind bracing as specified in **Section 7.9** on Roof Bracing.

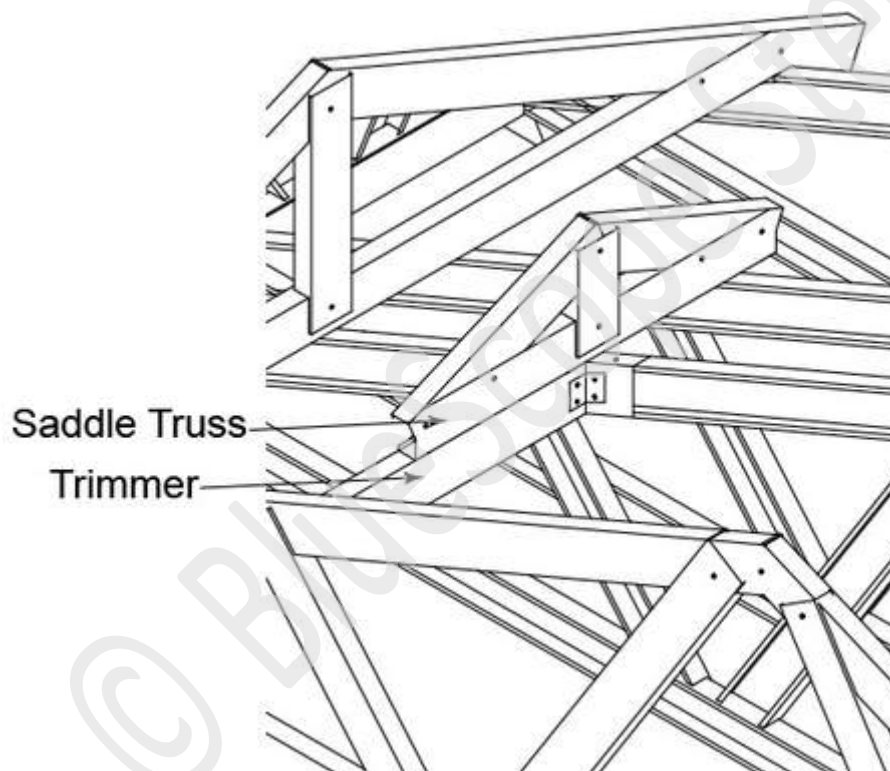

Figure 7.66 Saddle truss trimmer detail

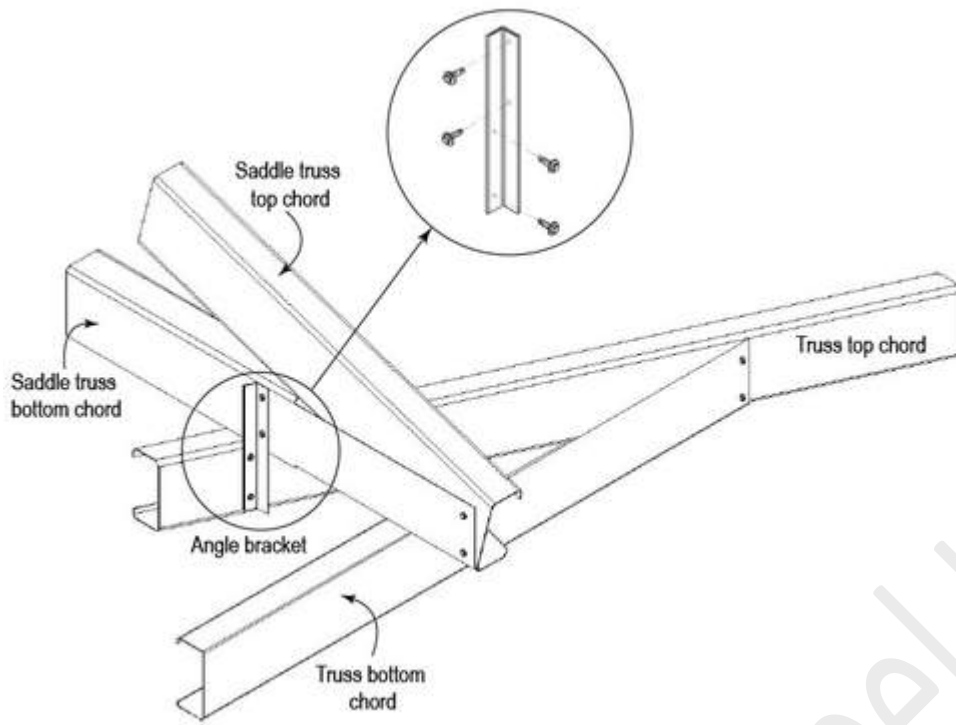
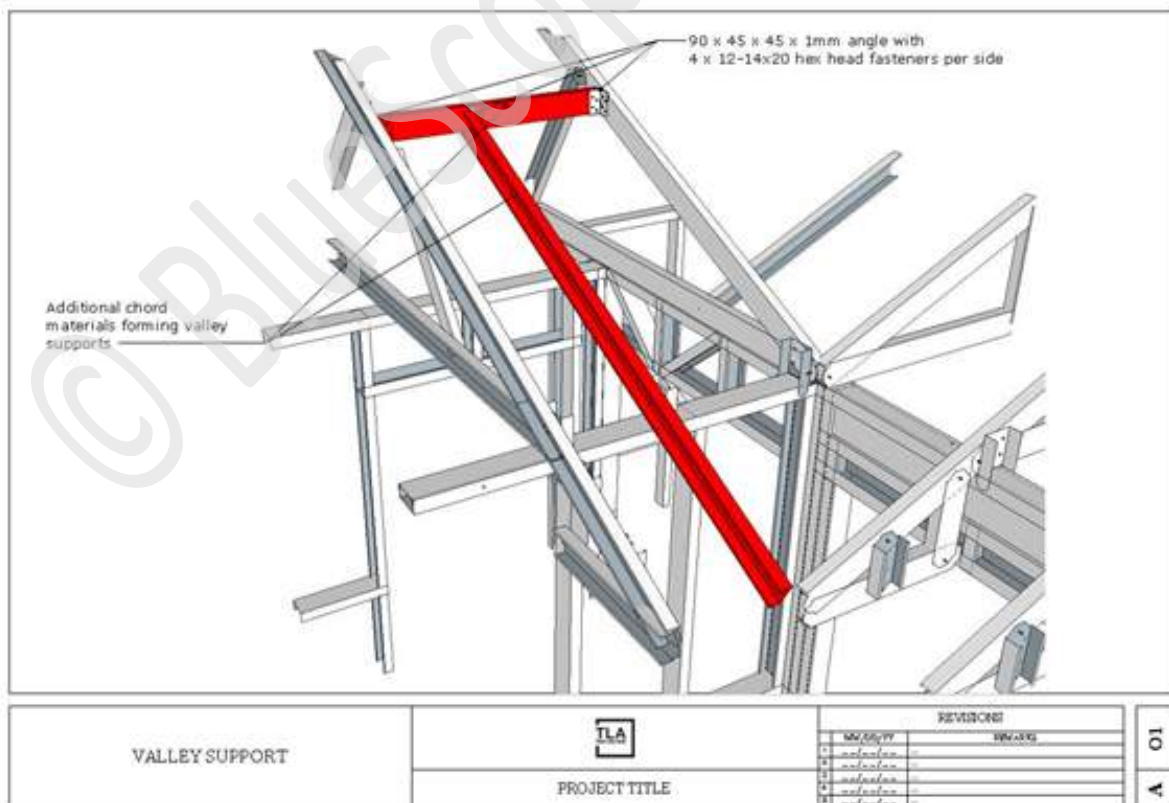

Figure 7.67 Saddle truss connection

7.6.3 Support for Lower Valley Ends

At the lower end of a valley junction, a rafter fabricated from scrap material can be placed to provide support for the fascia. Minimum section size to be the same as for common rafters required for the required span and overhang as specified in the Enduroframe design manual. Refer to graphic below.



VALLEY SUPPORT		REVISIONS		A 01
		NO.	DESCRIPTION	
PROJECT TITLE		1		
		2		
		3		
		4		
		5		
		6		

7.6.4 Radial Roof

A diagrammatic representation explaining the various elements of a radial truss is shown in **Figure 7.68**. Radial trusses consist of the following elements:

Girder truss. This is the same as standard girder trusses.

Barrel. This is connected to two vertical members on the girder truss and rotates around. A picture of the barrel including dimensions is shown in **Figure 7.69**.

Primary trusses. These are half trusses attached to the barrel radiating out from a central point on the girder truss and sit at the hip corners of the roof.

Note: the max length for half trusses to be used is 6m.

Secondary trusses. These are half trusses that are in between the primary trusses. They are placed when the Primary truss spacing exceeds the standard truss spacing in between the primary trusses at the eave line and may be attached to the face of the Barrel. These trusses typically remain perpendicular to the pitching line.

Intermediate trusses. These are the remaining trusses that are may be required between the Primary and Secondary trusses if the spacing is greater than the truss spacing at the eave.

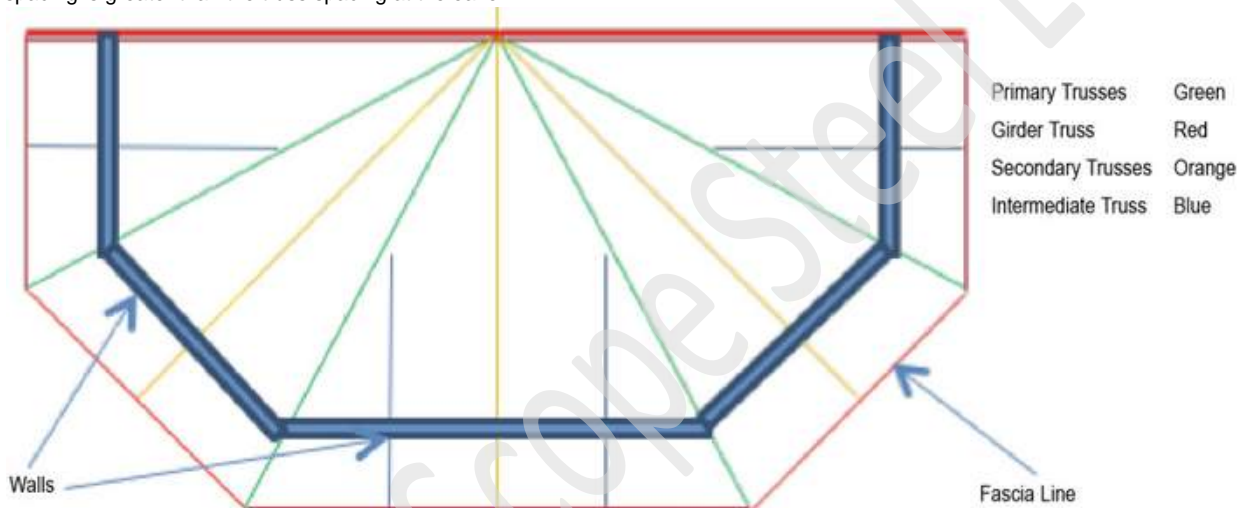

Figure 7.68 Radial truss key components

Radial roof construction

Step 1: Study the entire set of architectural and fabrication drawings. The Truss components in this area include the Girder, Primary, secondary and intermediate flush trusses.

Step 2: Set out and mark truss positions as per **Section 7.2**.

Step 3: If the Barrel(s) (pressed metal bracket(s)) have been sent as loose items, please fix to Girder truss as per the drawing below. The flat face of the girder truss provides a smooth face to attach 2 vertical rails which, in turn, support the barrel(s). Depending on the height of the truss will depend if there are one or two barrels. The lower barrel will be connected with a Trusstite through a pre-punched self-locating hole in the barrel, which is aligned with a self-locating hole in the vertical section and the truss chord. A total of 5 screws with either 12-14x20 hex head fasteners or 1 x Trusstite and 4x12-1x20 fasteners attached on each side of the barrel into the vertical section. The top barrel will usually be site fixed so the top chords of the half trusses do not clash, and will be fixed with 5x12-1 4x20 hex head fasteners.

Step 4: Install fixing brackets to support structure in marked positions.

Step 5: Lift Girder into set-out position. And fix two #12-14x20mm hex head self-drilling screws through the fixing bracket at each

heel connection into the truss Chord. If erection screws positions clash with truss manufacture fasteners remove these screws and replace with the erection screws through the bracket and into the chords in the same location.

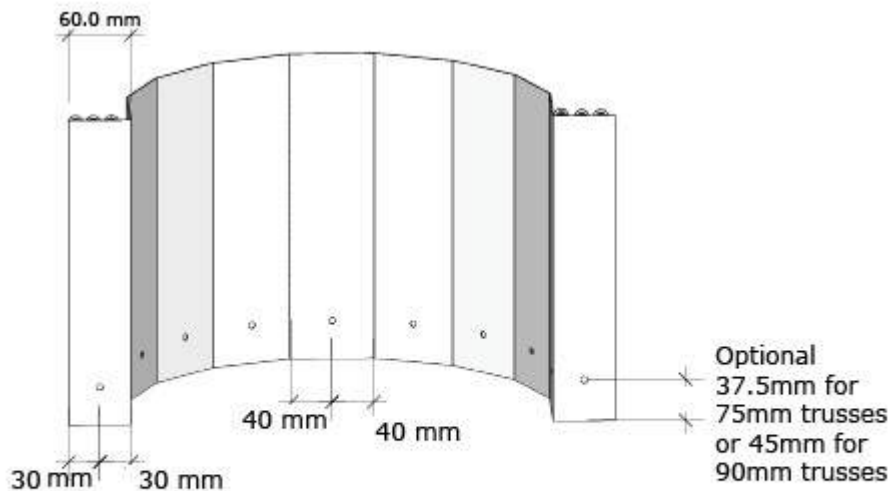

All holes are in the center of each segment of the barrel and are located 37.5mm from the end for a C75 truss or 45mm for a C90 truss

Figure 7.69 Barrel Brackets Details

Step 6: Temporarily brace the truss and ensure it is plumb and straight. This can be done using batten or roof bracing material fixed to the end wall and to the top chord of the truss.

Step 7: The Hip trusses (noted as the primary trusses) are next. Lift and place as per set out. Most commonly these hips run over the corners of the building. They are to be attached at the wall frame as per **Figures 7.24** and **7.26**. Depending upon the wind, dead load and span fixings needed. At the barrel end of the hip (primary) trusses, the bottom chord has a tab extending 40mm past the vertical chord. This is manually bent 90 degrees so the 6mm locating hole can be used to align the bottom of the truss to pre-punched holes in the barrel to get the correct height. The top chord on the other hand extends and runs over the barrel to give a more complete hip line and for battens to connect to. Half trusses are connected onto the face of the barrels with an additional 4x12-14x20 hex head fasteners as per **Figure 7.71** and **7.72**. Or If not using the Trusstite use 5x12-14x20 hex head fasteners. The load from the half truss is transferred to the barrel with these fasteners.

Note: These fastenings can be made from front or back faces of the barrel.

Step 8: Lift the secondary trusses following the same set out as step 7 and the same process where it meets the barrel but will actually sit perpendicular to the wall frame and can be attached to the wall frame with hold down methods suitable.

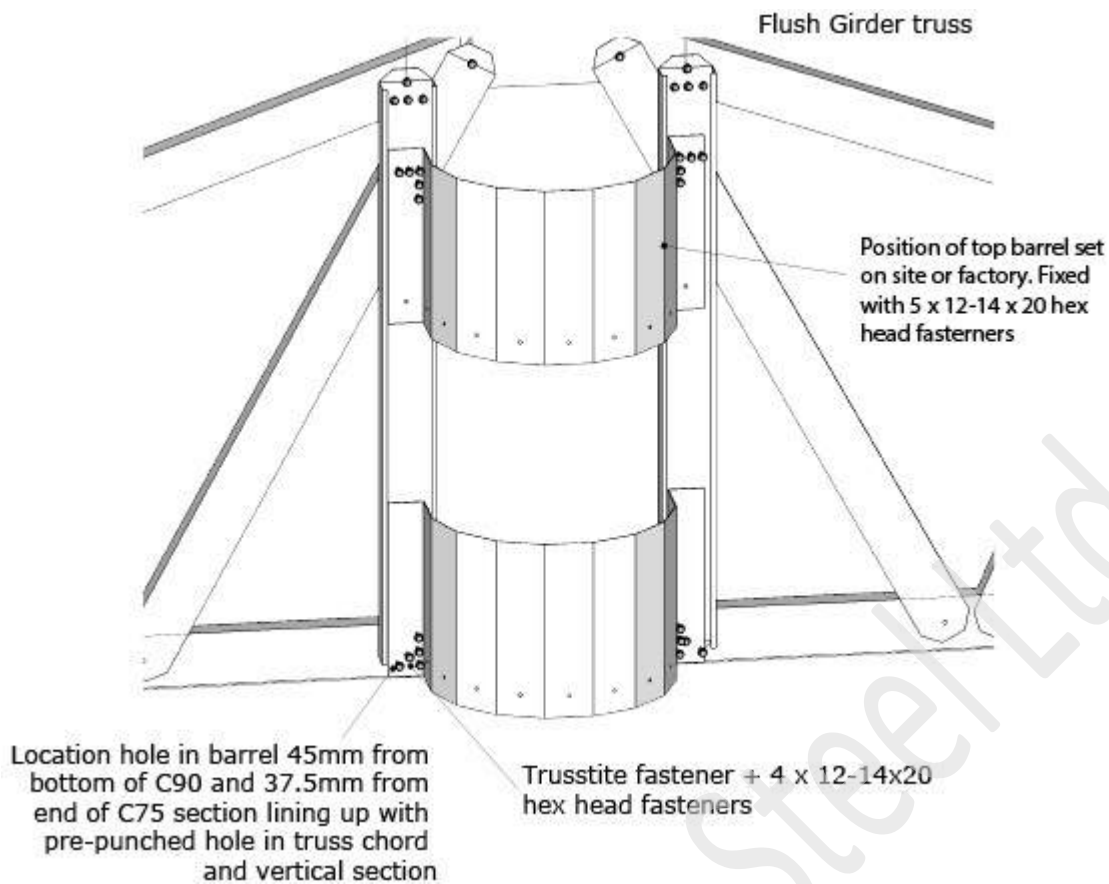

Figure 7.70 Position of barrels on vertical section

Step 9: Lift the remaining intermediate trusses into their required position and use the same tie down fixing on the wall frame as per the secondary trusses. Where these intermediate trusses join to the primary trusses ensure that some partial boxing plate is added (to the open side of the primary truss) and fixed with 4x12-14x20 hex head fasteners through the flanges towards the ends of this piece. These intermediate trusses have an extension to the top chord that will manually need to be bent to fix to the primary truss as this area. This bent tab is attached with 2x2-14x20 fasteners through this top chord extension into the top chord of the oncoming truss. The bottom chord also is extended of this intermediate truss and follows the same partially boxing method as just described. Refer to **Figures 7.73** and **7.74**.

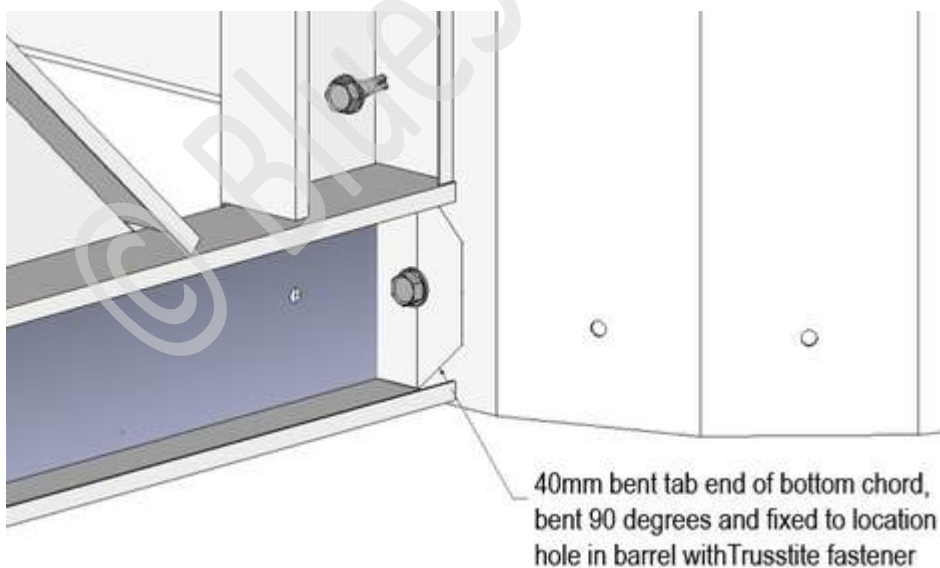

Figure 7.71 Bend tab at end of half truss to locate the bottom chord onto a pre-punched hole in the barrel

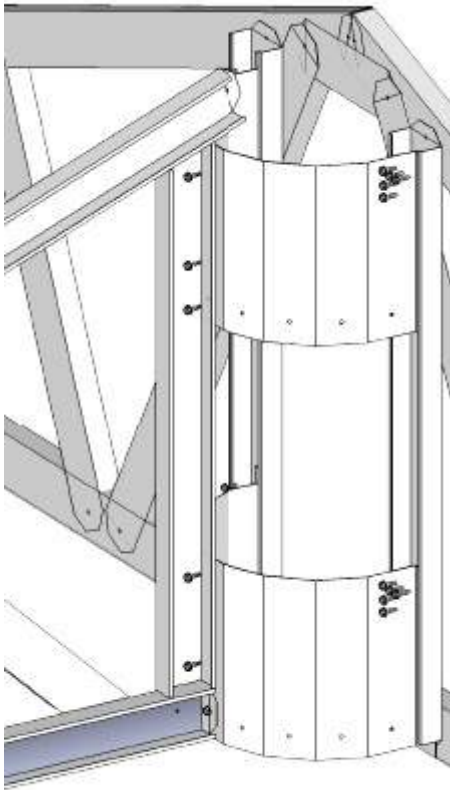

Figure 7.72 Connecting half trusses to barrels with 1 x Trusstite and 5 x 12-14x20 hex head fasteners

Half trusses are connected onto the face of the barrel with an additional 5 x 12-14x20 hex head fasteners as per Figure 7.65. The fasteners can be screwed through the back of radial to truss if required. The load from the half truss is transferred to the barrel with these fasteners. Fasteners can also be installed from back of barrel.

The end of the intermediate truss top chord extends past the primary truss by 40mm. It is notched on both flanges and is manually bent, and attached with 2 x 12-14x20 hex head fasteners.

The end of the intermediate truss bottom chord extends past the primary truss by 40mm. It is notched on both flanges and is manually bent, and attached with 2 x 12-14x20 hex head fasteners.

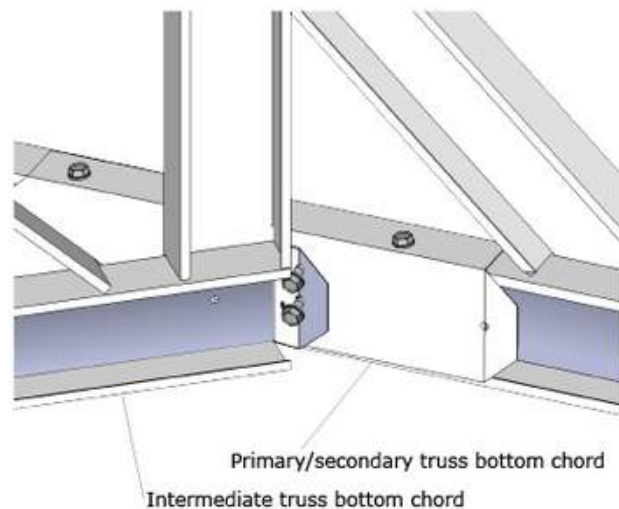
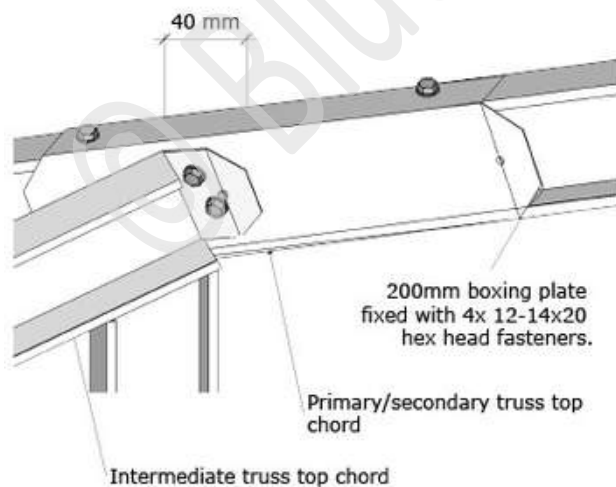

Figure 7.73 Connection between primary and intermediate truss (Top Chord) and intermediate truss (Top Chord)

7.7 Common roof block construction

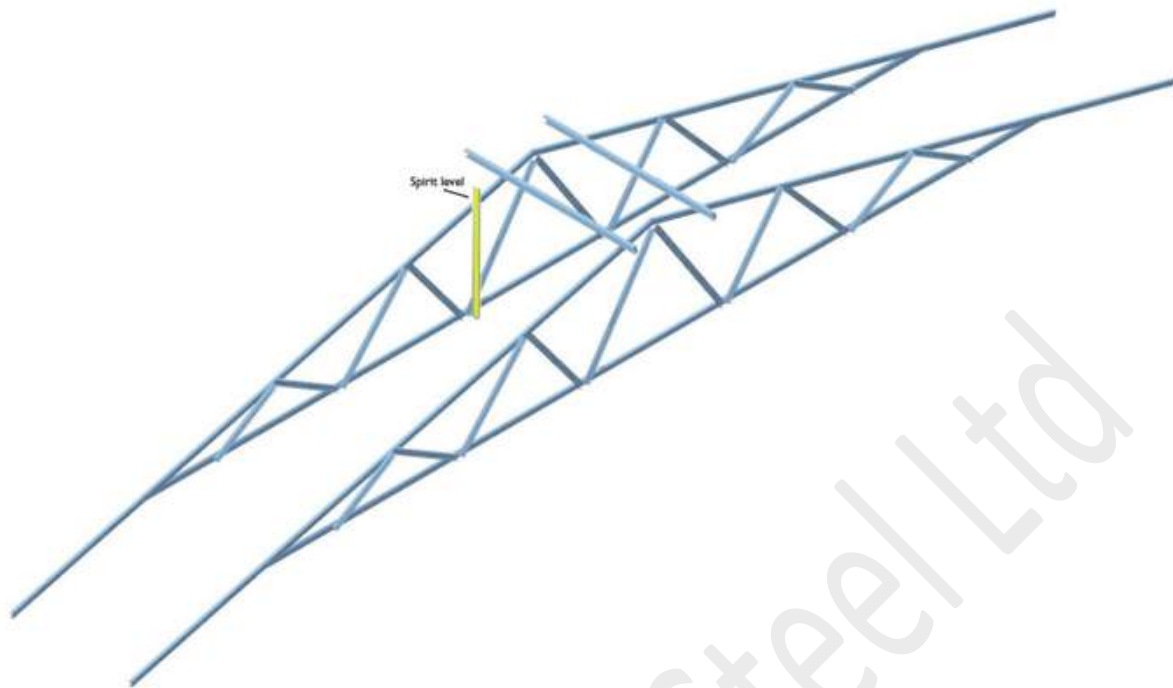

Figure 7.75 Use spirit level to plumb truss

Step 1: Study the entire set of architectural and fabrication drawings.

Step 2: Mark out truss positions on the top plate as per the Roof Framing Layout. Refer to **Section 7.2** on Roof Truss Set-Out.

Step 3: Install gables, hips and Dutch gables in accordance with **Sections 7.3, 7.4** and **7.5** of this manual. Install remaining trusses in their set-out positions and secure using two #12-14x20mm hex head tek screws through the fixing bracket at each heel connection into the side of the top plates. Temporarily brace as close as possible to the apex of each truss to plumb and straighten.

Note: To keep trusses in-line, simply maintain a straight line at the apex of all trusses this can be done using a string line. Alternatively, run a string line along a common point on the trusses.

Note: When all trusses are erected, install wind bracing as specified in **Section 7.9** on Roof Bracing.

7.8 Truss and Rafter Tie Down Connections

The designer should specify the tie down system to be used for each job with reference to ENDUROCAD® truss and rafter reactions and standard connection design capacities. The truss and rafter reactions to be resisted are calculated by the ENDUROCAD® software, however a ready reckoner on the reactions to be resisted under a range of roof truss spacings, spans and wind loads are shown in **Tables 7.8.2a, 7.8.2b** and **7.8.2c**. Note that these tables may be more conservative than the values calculated by the ENDUROCAD® software.

Table 7.8.2a. Truss Downward Reactions for a Tile Roof in a non-cyclonic region

1000mm Overhang	TRUSS DOWNWARD REACTIONS AT TOP PLATE (KN) UNDER TILE ROOF								
	TRUSS CENTRES (mm)								
	600			900			1200		
Truss Span	N1	N2	N3	N1	N2	N3	N1	N2	N3
4	3.08	3.39	4.02	4.42	4.89	5.84	5.76	6.39	7.66

5	3.50	3.86	4.59	5.06	5.60	6.69	6.62	7.33	8.79
6	3.93	4.33	5.15	5.70	6.31	7.53	7.47	8.28	9.91
7	4.36	4.81	5.71	6.35	7.02	8.38	8.33	9.23	11.04
8	4.79	5.28	6.28	6.99	7.73	9.22	9.19	10.17	12.17
9	5.22	5.75	6.84	7.63	8.44	10.07	10.04	11.12	13.30
10	5.64	6.23	7.41	8.27	9.15	10.91	10.90	12.06	14.42
11	6.07	6.70	7.97	8.92	9.86	11.76	11.76	13.01	15.55
12	6.5	7.17	8.53	9.56	10.56	12.61	12.61	13.96	16.68
13	6.93	7.65	9.10	10.20	11.27	13.45	13.47	14.90	17.81
14	7.36	8.12	9.66	10.84	11.98	14.30	14.33	15.85	18.93
15	7.79	8.59	10.22	11.49	12.69	15.14	15.18	16.80	20.06

Table 7.8.2b Truss Uplift Reactions at Top Plate under a Sheet Roof – Non-Cyclonic

1000mm Overhang	TRUSSUPLIFT REACTIONS AT TOPPLATE (KN) UNDER SHEET ROOF									
	Truss Span	TRUSS CENTRES (mm)								
		600			900			1200		
	N1	N2	N3	N1	N2	N3	N1	N2	N3	
4	1.16	1.77	3.00	1.74	2.65	4.50	2.32	3.54	6.00	
5	1.32	2.02	3.43	1.98	3.02	5.14	2.64	4.03	6.85	
6	1.48	2.26	3.85	2.22	3.40	5.78	2.96	4.53	7.70	
7	1.64	2.51	4.28	2.46	3.77	6.41	3.28	5.02	8.55	
8	1.80	2.76	4.70	2.70	4.14	7.05	3.60	5.51	9.40	
9	1.96	3.00	5.13	2.94	4.51	7.69	3.91	6.01	10.25	
10	2.12	3.25	5.55	3.17	4.88	8.33	4.23	6.50	11.10	
11	2.28	3.50	5.98	3.41	5.25	8.96	4.55	7.00	11.95	
12	2.43	3.74	6.40	3.65	5.62	9.60	4.87	7.49	12.80	
13	2.59	3.99	6.83	3.89	5.99	10.24	5.19	7.98	13.65	
14	2.75	4.24	7.25	4.13	6.36	10.88	5.50	8.48	14.50	
15	2.91	4.49	7.68	4.37	6.73	11.52	5.82	8.97	15.35	

Table 7.8.2c Truss Uplift Reactions at Top Plate under a Sheet Roof – Cyclonic

1000mm Overhang	Truss Uplift Reactions at Top Plate under a Sheet Roof – Non-Cyclonic					
	TRUSS CENTRES (mm)					
	TRUSS SPAN (m)	600			900	
	C2	C3	C4	C2	C3	C4
4	6.01	9.04	12.36	9.02	13.56	18.54
5	7.01	10.55	14.42	10.52	15.83	21.63
6	8.01	12.06	16.48	12.02	18.09	24.72
7	9.02	13.56	18.54	13.52	20.35	27.81
8	10.02	15.07	20.60	15.03	22.61	30.90
9	11.02	16.58	22.66	16.53	24.87	33.99
10	12.02	18.09	24.72	18.03	27.13	37.08

Note:

- 1) The wind pressure coefficients to determine Truss Uplift Reactions are based on AS 4055-2011 Table 3.1
- 2) Truss uplift reactions are based on most critical design conditions (slope, input parameters of Pressure Coefficients from AS 4055)

etc.).

3) Accurate uplift reactions to suit the truss /building layout configuration and AS 1170.2 wind pressure coefficients can be obtained from ENDUROCADD® Software Engineering sheet output.

Based on the reactions selected from **Tables 7.8.2a, 7.8.2b or 7.8.2c** an appropriate tie down shall be selected. The selection of an appropriate tie down depends on a number of factors:-

1. The thickness of the truss chord;
2. The thickness of the top plate;
3. The thickness of the stiffening piece;
4. Whether the trusses are landing in between studs, are directly tied to a stud or above a 200 x 30 x 1.5mm lintel;
5. The type of tie down selected;
6. The tie down should be selected AFTER the truss, top plate, stud, and stiffener thicknesses have been determined, and whether the studs are aligned under trusses or will be attached to a 1.5mm thick lintel. The top plate should be checked for truss downward reactions. The tie downs can be selected in the ENDUROCADD® software and shown on tie down sheets, however **Table 7.8.3** can also be used as a guide based on a selection of truss and wall frame configurations.

Table 7.8.3 – Connection Capacity of various configurations of truss chords, studs, top plates and tie downs

Top Plate Thick	Min. Truss Chords Thick	Top plate stiffener used	Min. Stud & Stiffener Thick	Connection Capacity (kN)											
				Tie Down type***											
				A	2A	B	2B	C	2C	D	E	F			
0.75	0.75	Yes	0.75	3.8	5.6	4.9	5.6	5.6	5.6	-	-	-	-	-	-
1.0	0.75	Yes	1.0	3.8	7.6	4.9	8.5	8.4	8.5	-	-	-	-	-	-
1.0	0.75	Yes	1.2	3.8	7.6	4.9	9.3	8.4	9.3	-	-	-	-	-	-
1.0	1.0	Yes	0.75	4.4	7.4	6.0	7.4	7.4	7.4	-	-	-	-	-	-
1.0	1.0	Yes	1.0	4.4	8.5	6.0	8.5	8.5	8.5	-	-	-	-	-	-
1.0	1.0	Yes	1.2	4.4	8.8	6.0	9.3	9.3	9.3	-	-	-	-	-	-
1.2	0.75	Yes	0.75	3.8	7.4	4.9	7.4	7.4	7.4	-	-	-	-	-	-
1.2	0.75	Yes	1.0	3.8	7.5	4.9	9.6	8.4	9.6	-	-	-	-	-	-
1.2	0.75	Yes	1.2	3.8	7.5	4.9	9.8	8.4	12.3	-	-	-	-	-	-
1.2	1.0	Yes	0.75	4.4	7.4	6.0	7.4	7.4	7.4	-	-	-	-	-	-
1.2	1.0	Yes	1.0	4.4	8.8	6.0	9.6	9.6	9.6	-	-	-	-	-	-
1.2	1.0	Yes	1.2	4.4	8.8	6.0	12.0	12.3	12.3	-	-	-	-	-	-
0.75*	1.0	No	0.75	-	-	-	-	-	-	27	-	-	-	-	-
0.75	1.0	No	1.0	-	-	-	-	-	-	-	23.7	-	-	-	-
NA**	0.75	NA	NA	-	-	-	-	-	-	-	-	-	-	-	18.6

Each option assumes that the plates are connected to studs with 1 x M6x1Px15mm smooth top fastener on each side of the plate.

- Option requires a 200 x 35 x 1.5mm lintel to be installed.
- For bolting to a masonry wall or structural steel connection with a minimum M12 bolt through a 50 x 3mm square washer.

A 2 in front of the connection type denotes a double connection into a boxed section.

A description of the Tie Down types is shown in Table 7.8.4

Table 7.8.4

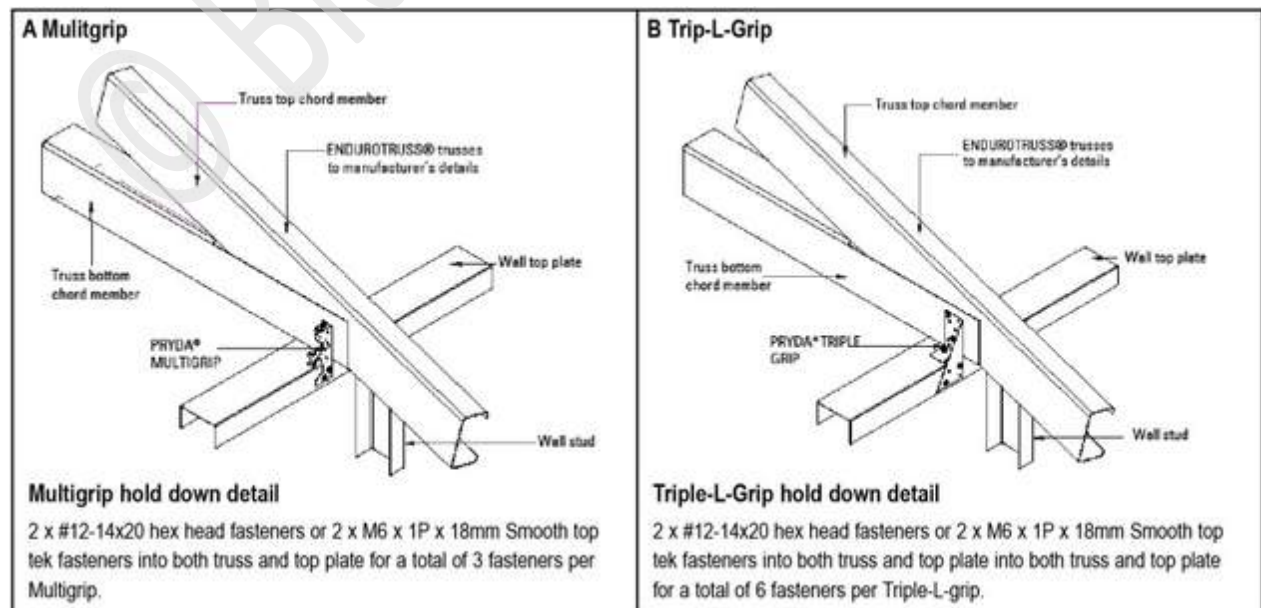

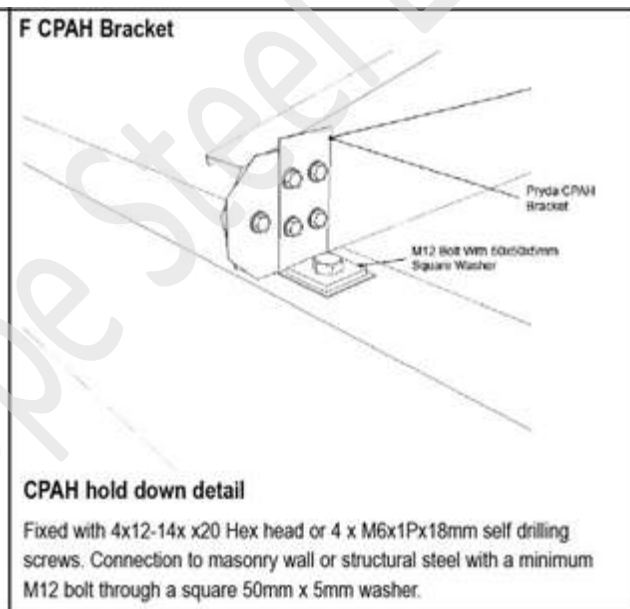
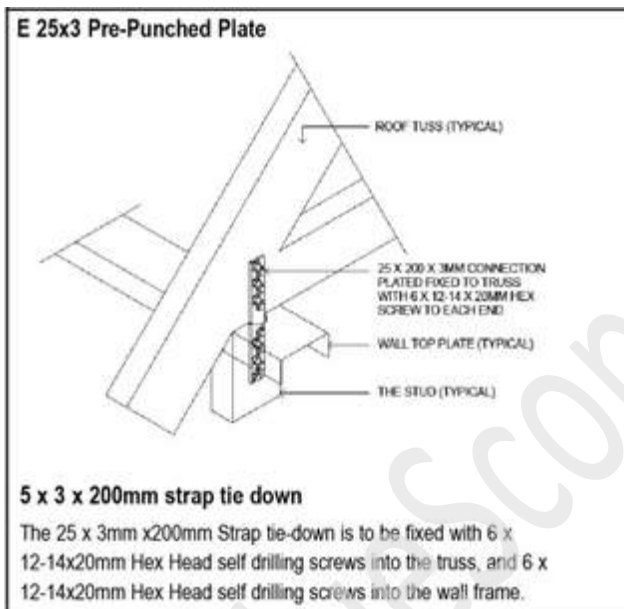
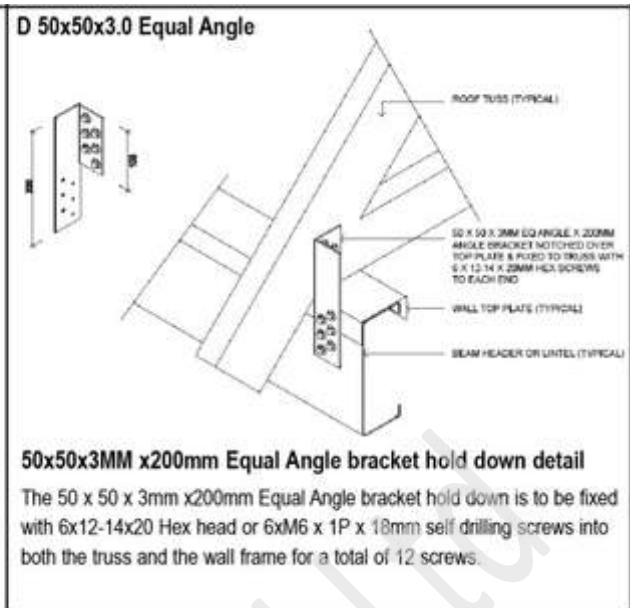
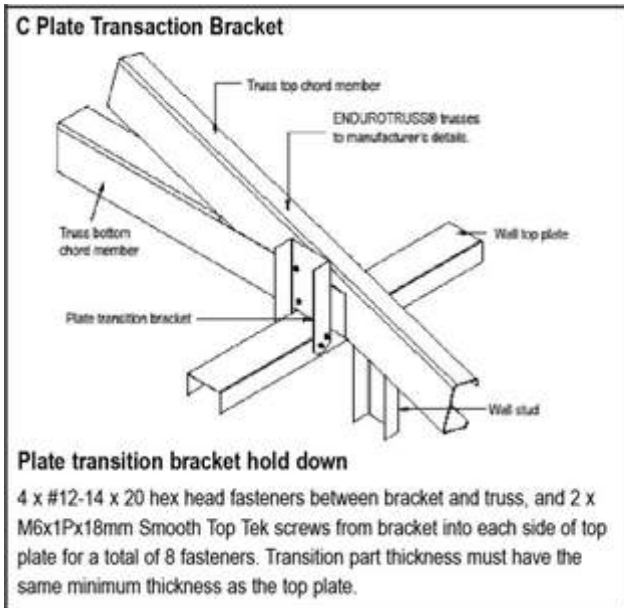

7.8.1 Boxed Tie Downs

To attach a tie down to the reverse side of a truss or rafter the section will need to be boxed with a 200mm long boxing piece. This boxing piece can be cut back from a piece of scrap steel and attached to the truss. For apex trusses the boxing piece will be connected to the top chord of the trusses as per **Figure 7.76**. For half trusses with vertical chords the boxing plate may be attached to either the vertical or horizontal chords as per **Figure 7.77**.

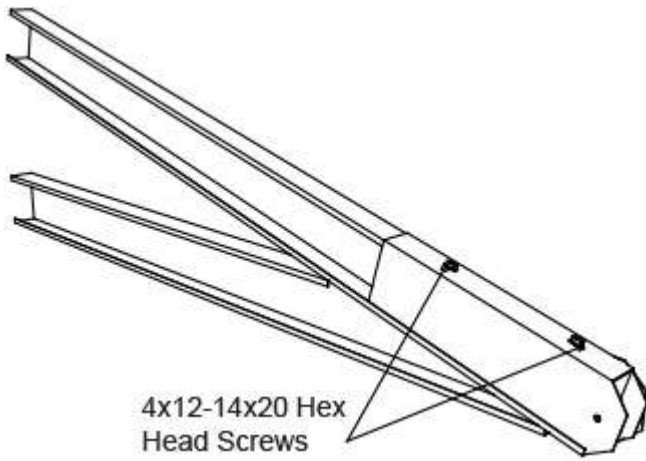

Figure 7.76 figure boxing piece to truss top chord

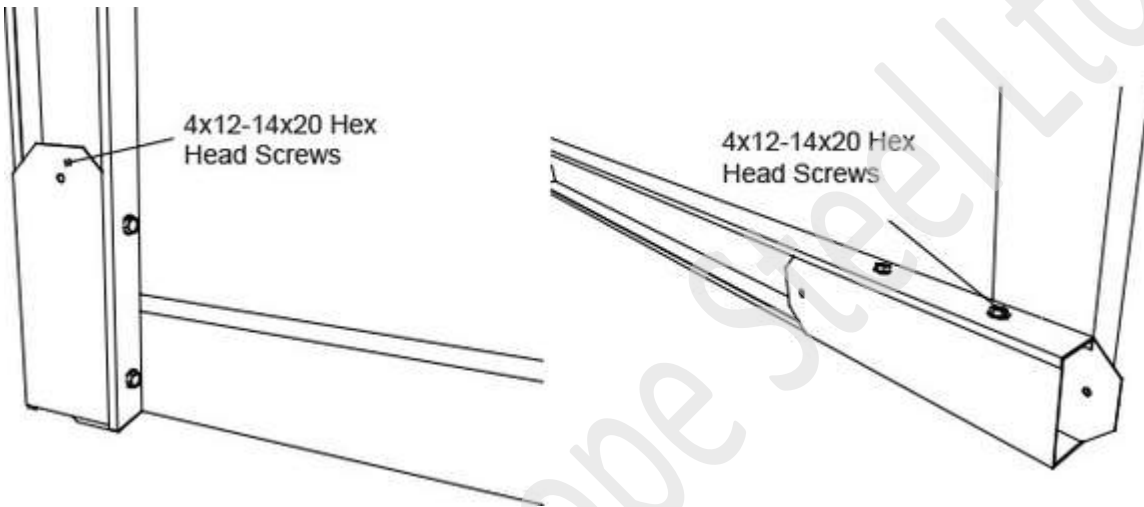

Figure 7.77 200mm boxing piece fixed to either horizontal or vertical chords on a half truss

Tie downs are then fixed to the boxing piece using the quantities of fasteners shown in **Table 7.8.4** for the respective tie downs. An example of the tie down methodology is shown in **Figure 7.78** for triple grips. Other tie downs are fixed in a similar manner.

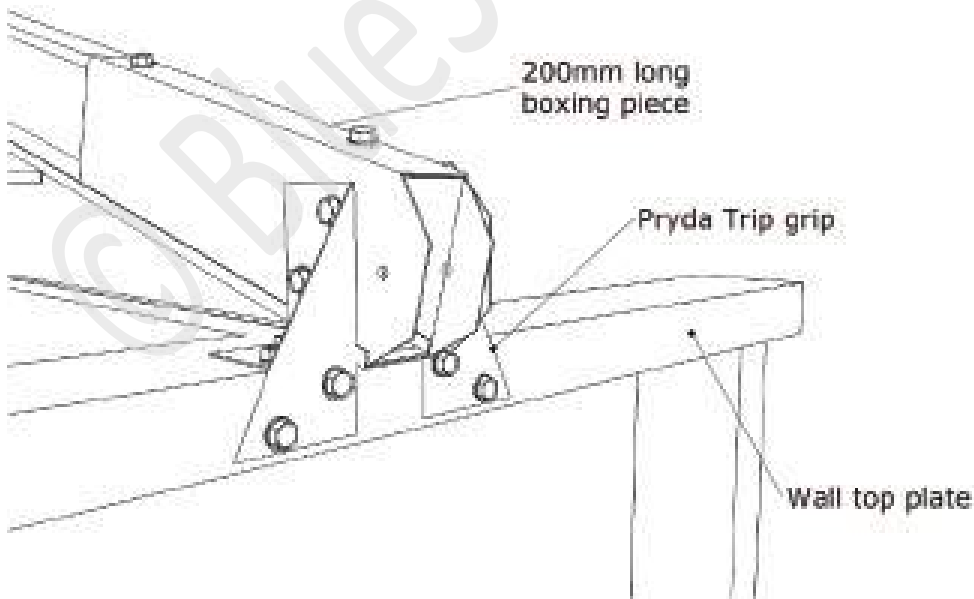

Figure 7.78 Fixing double tie downs to truss and top plate (Triple grips shown)

7.9 Roof bracing

Roof bracing can be broadly classified into four groups:

1. Temporary bracing for installed top chord
2. Roof cross bracing
3. Bottom chord bracing
4. Web bracing.

An example of roof cross bracing is shown in **Figure 7.79**.

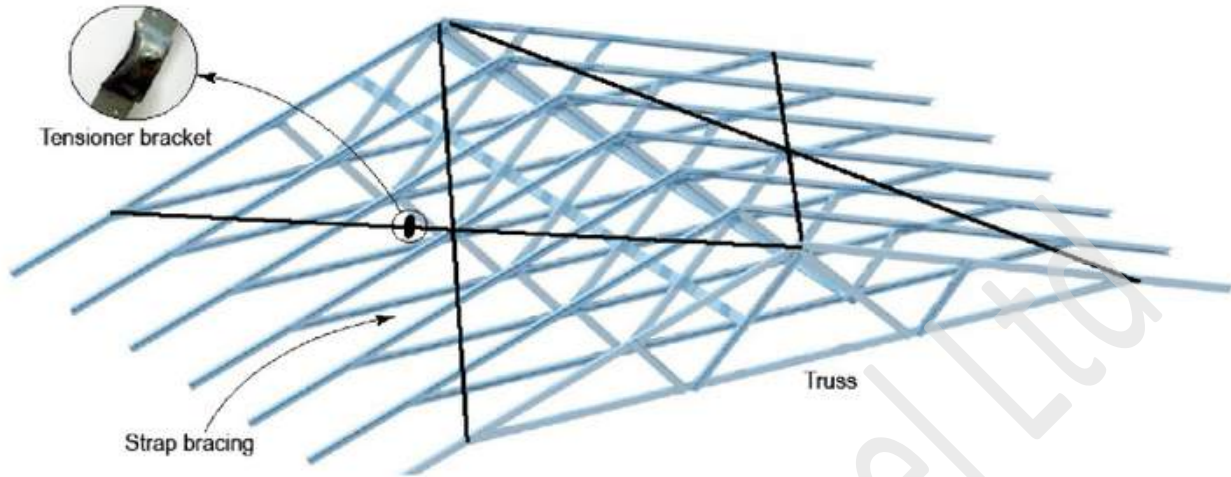

Figure 7.79 Roof cross bracing using strap bracing

7.9.1 Temporary bracing

Temporary bracing should be in place to support trusses until all bracing is installed. Temporary ties should be made in accordance with **Table 7.9.1**. Ties should be fixed to each truss with a minimum of one #12-14x20 screw. Steelbrace is not acceptable for temporary bracing.

Temporary braces may be truss or batten sections. Minimum sizes are shown in **Table 7.9.1** below. Unless requested, temporary bracing materials are not supplied. Care should be taken that supplied parts used as temporary bracing are removed after permanent bracing is installed for use in their intended location.

Table 7.9.1 Size of temporary ties

Truss spacing	To Top Chord	To Bottom Chord
Up to 1200	TOPSPAN@40 x 0.55/ C7555 / C9055 @ maximum 3m spacings	@22 x 0.42/ C7555 / C9055 @ maximum 3m spacings

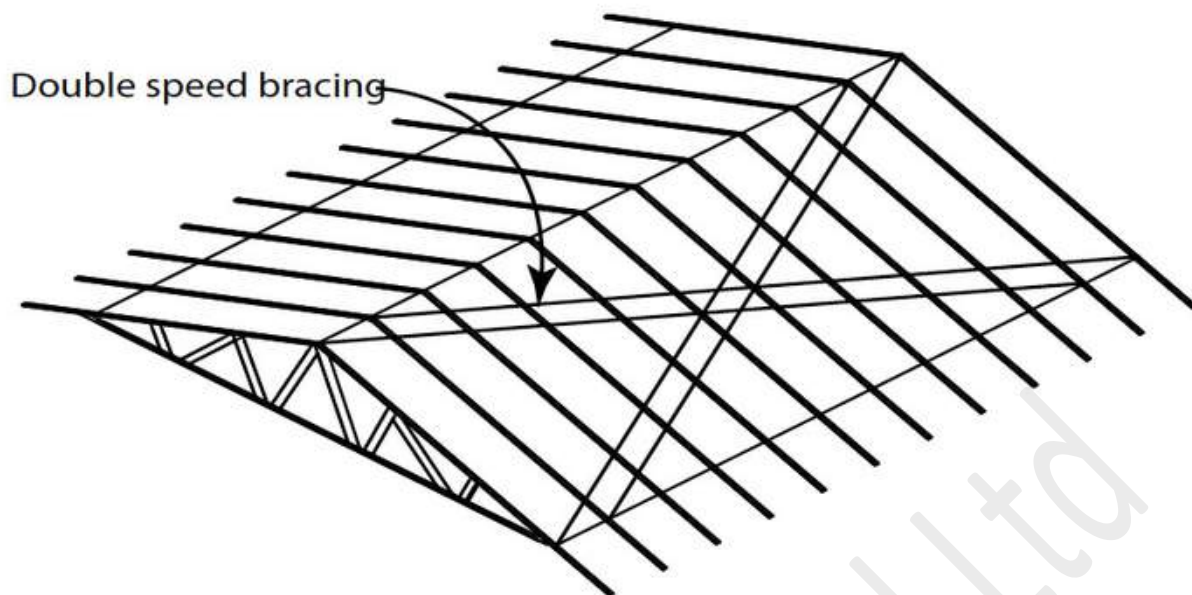

Figure 7.80 Double speed brace

7.9.2 Cross Bracing

Speed strap brace must be a minimum 32 x 1.2mm (min.) with minimum tension capacity of 8.4 kN. Bracing may be larger and may have a bend to make installation easier by keeping the bracing straight without any sagging. Proprietary bracing system may be used conforming to AS 4440:2004. Where single speed brace is insufficient, double speed brace needs to be provided as shown in **Figure 7.80**. Refer to the table below for single or double speed brace. Strap bracing with tensioners is another form of cross bracing.

7.9.2.1 Fixings

Bracing should be fixed to apex of A-truss as shown in **Figure 7.82**.

Bracing should be fixed to wall top plate adjacent to truss positions as shown in **Figure 7.83**. Fix bracing to each intermediate truss using 1 x 12-14x20 hex head screws as shown in **Figure 7.81**.

For cantilevered trusses and cut-off/half trusses, bracing should be fixed as shown in **Figure 7.85**.

Step 1: Apex fixing

Fasten the brace to the outside edge of the top chord of the gable end truss at the apex and lay it diagonally down the slope, at an angle 30° - 45° to the truss line.

Step 2: Wall fixing

Fix the other end to the outer flange of the top wall plate. Ensure that the trusses are plumb.

Step 3: Tensioning

When all the braces have been installed, check that trusses are plumb and straight, and are effectively tied together with temporary battens. Where strap brace is used, fix bracing to the apex of the first truss and at the wall adjacent to the last truss as shown in **Figure 7.79**. Tension bracing before fixing to intermediate trusses with tensioner bracket and fix strap to each truss.

Fix braces to the upper face of the top chord at each intersection.

Figure. 7.81 Brace to chord connection

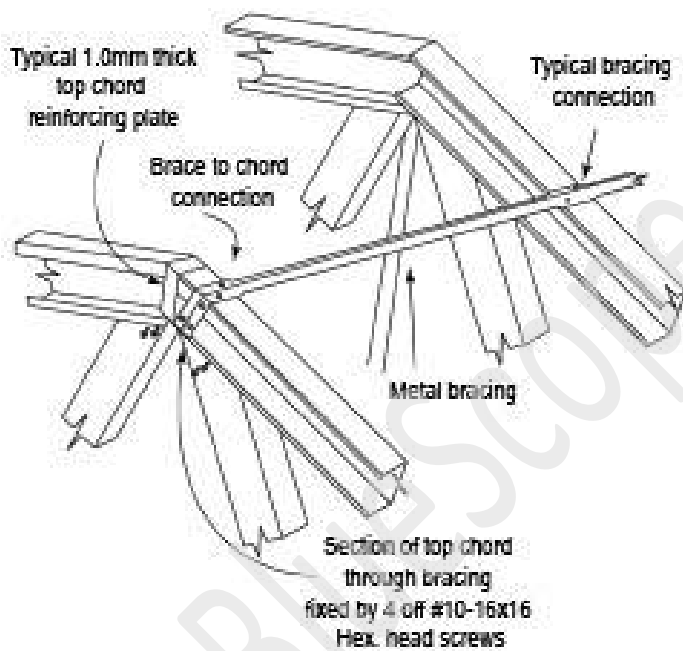
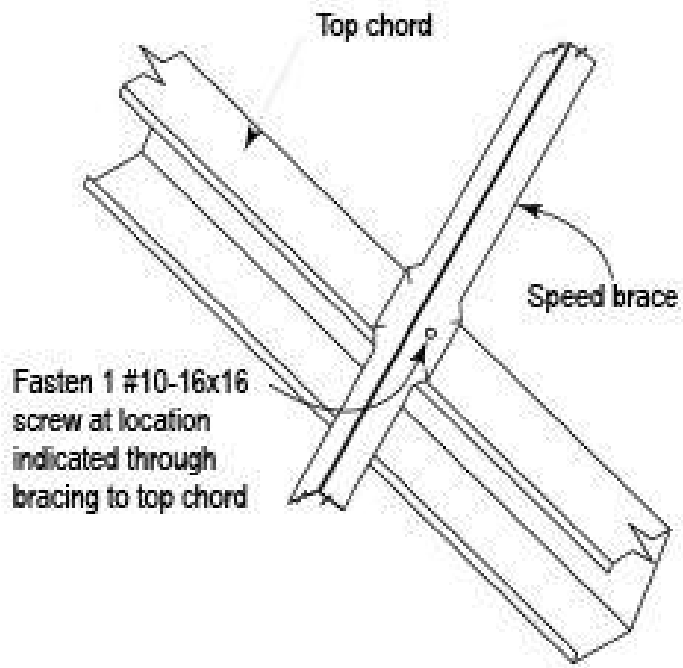

Figure 7.82 End fixing at apex

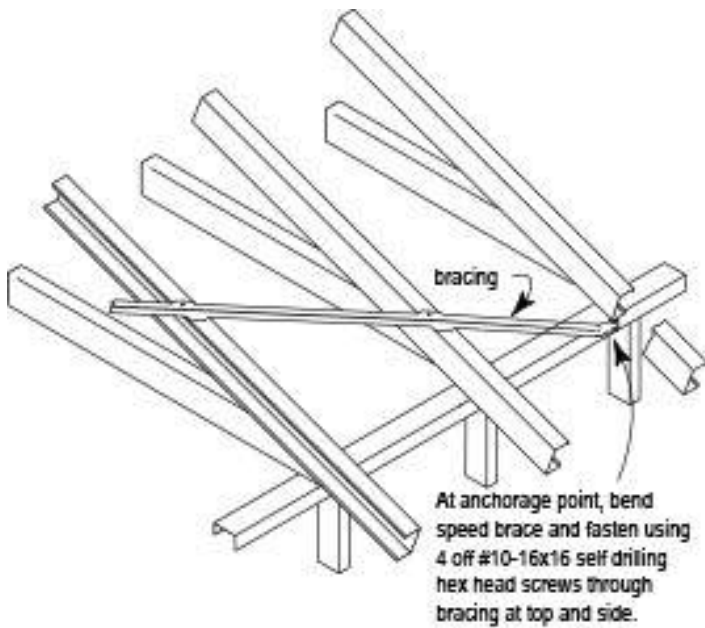

Figure 7.83 Fixing at anchorage point at wall top plate

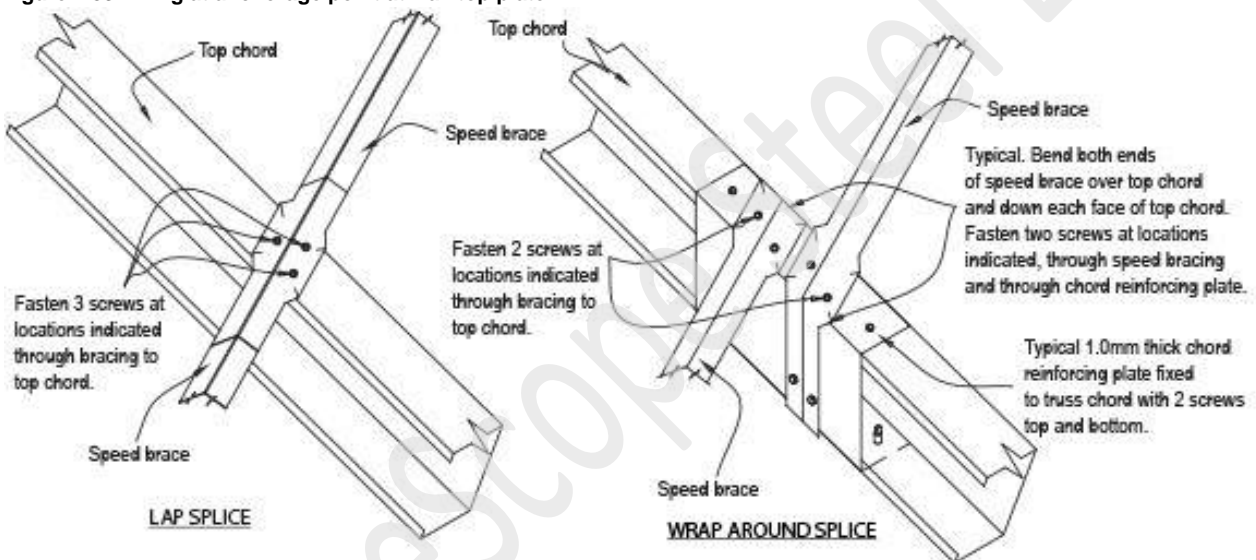
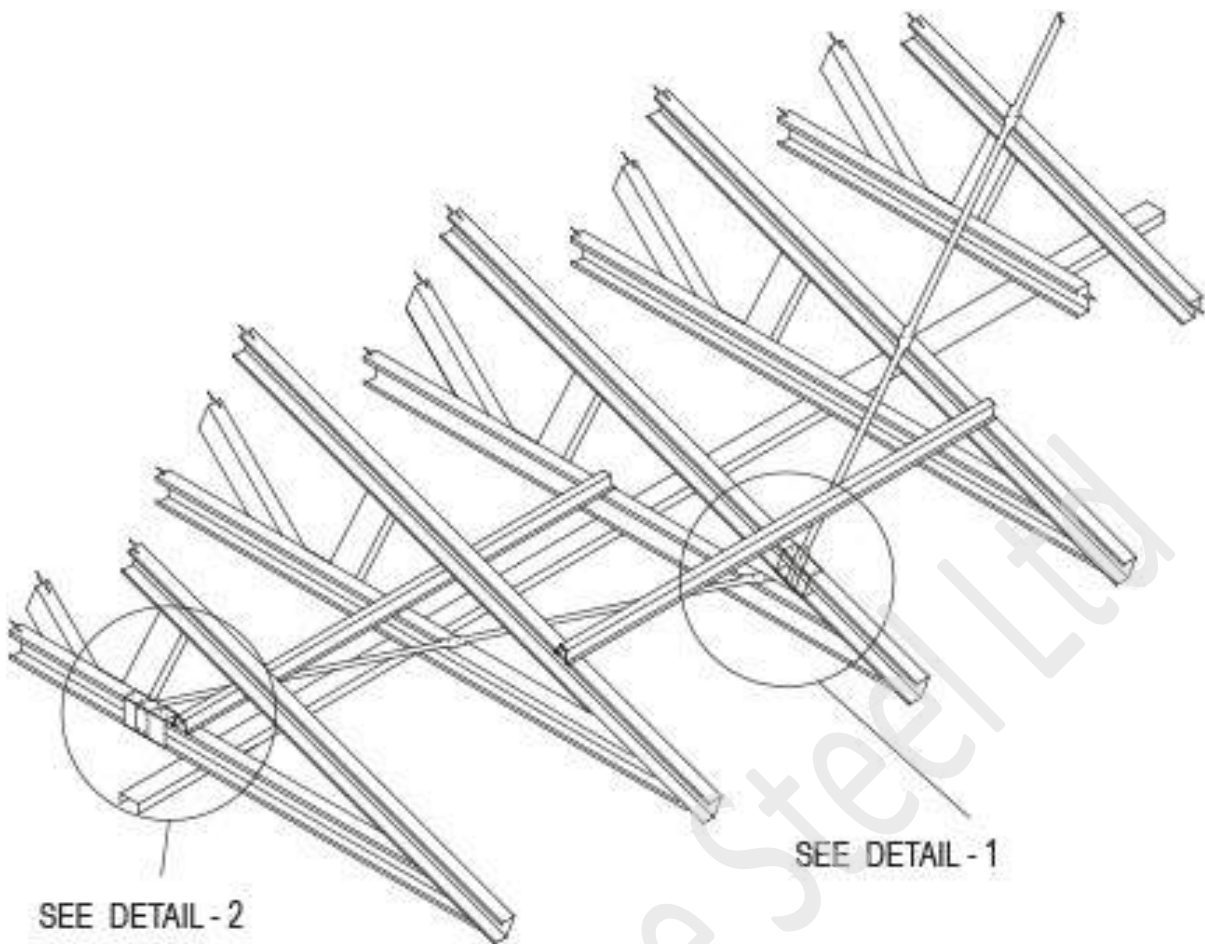

Figure 7.84 Typical splice detail



SEE DETAIL - 2

SEE DETAIL - 1

Locate and fold down speed strap bracing to vertical face of bottom chord of truss. Fasten speed bracing to vertical face of bottom chord with 4 screws.

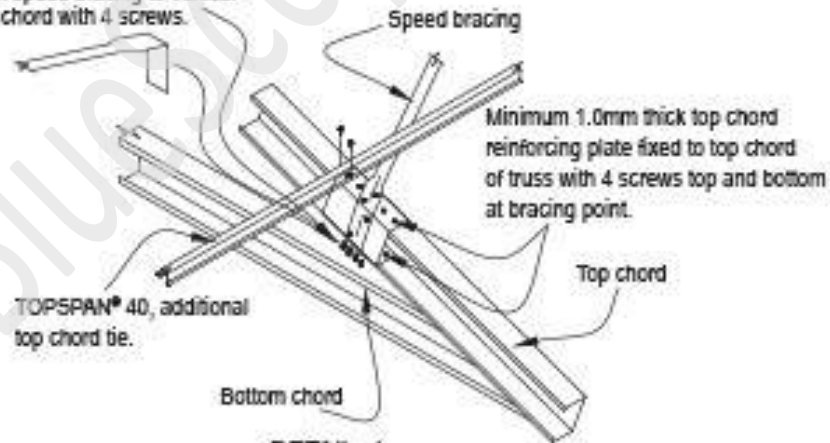

DETAIL - 1

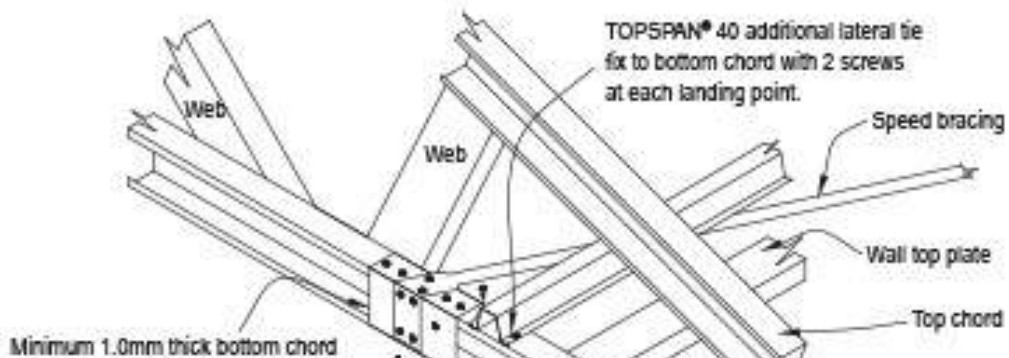

reinforcing plate fixed to bottom chord
of truss with 4 screws top and bottom
at bracing point.

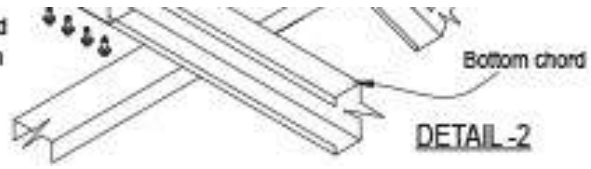

© BlueScope Steel Ltd

Figure 7.85 Fixing details for cantilevers

© BlueScope Steel Ltd

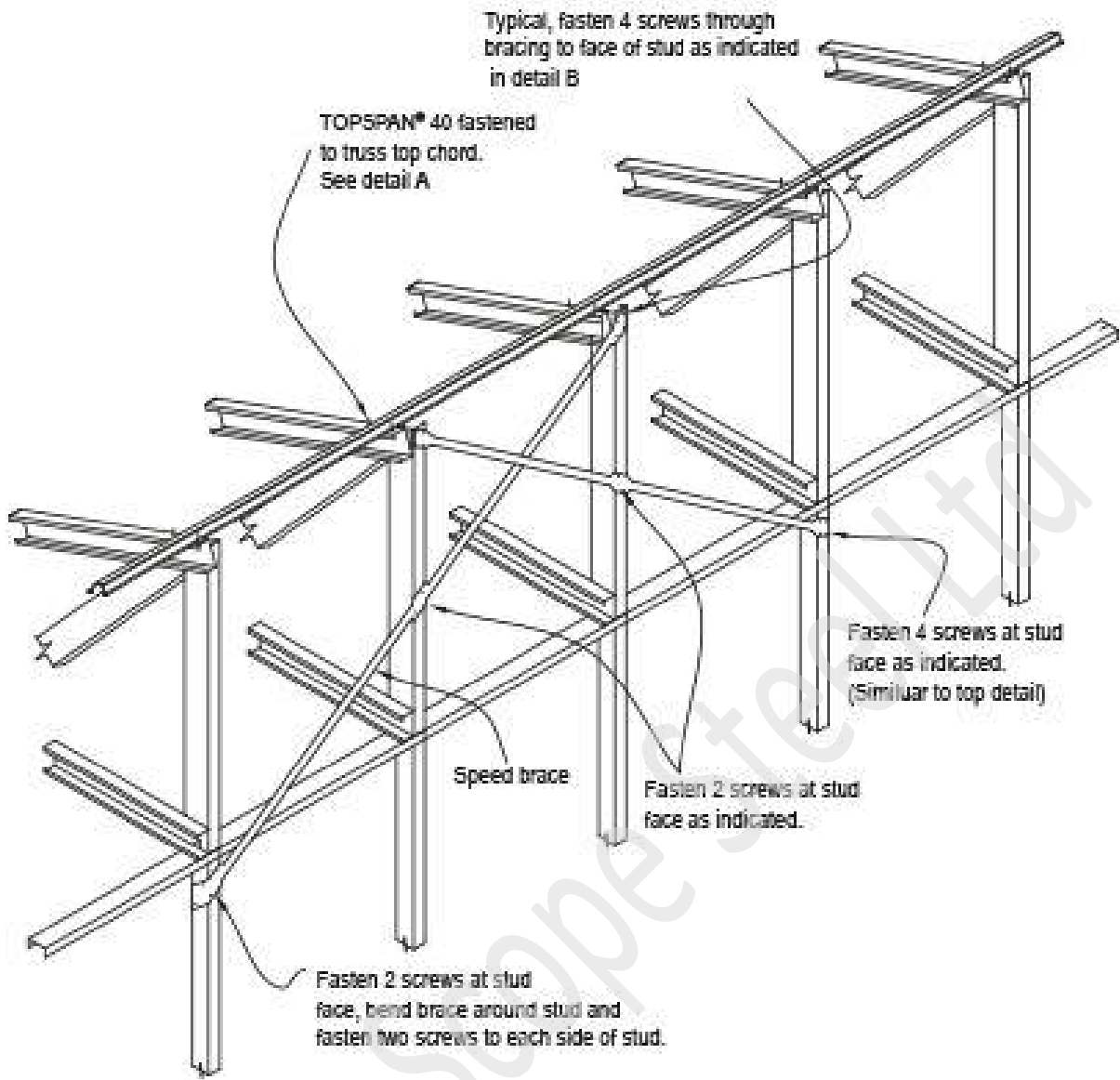

Detail A

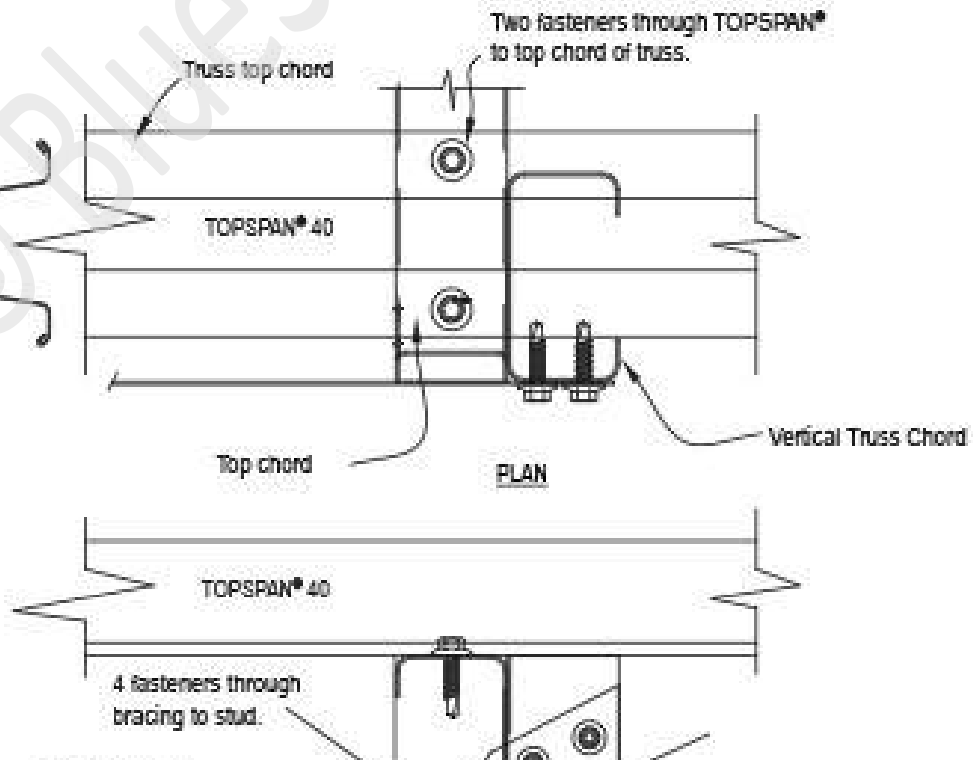

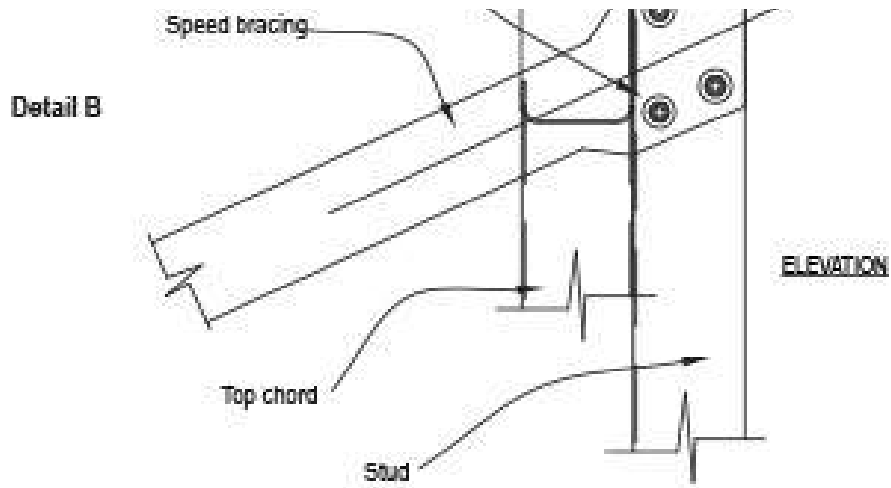

Figure 7.86 Fixing details for cut off or half trusses

7.9.2.2 Bracing Layout

The type and layout of the top chord steel brace are related to the truss span, shape and loading of the roof. The area of the standard truss overhangs is not required to be braced.

7.9.2.3 Gable roof bracing layout

© BlueScope Steel Ltd

Truss Spans up to 8m

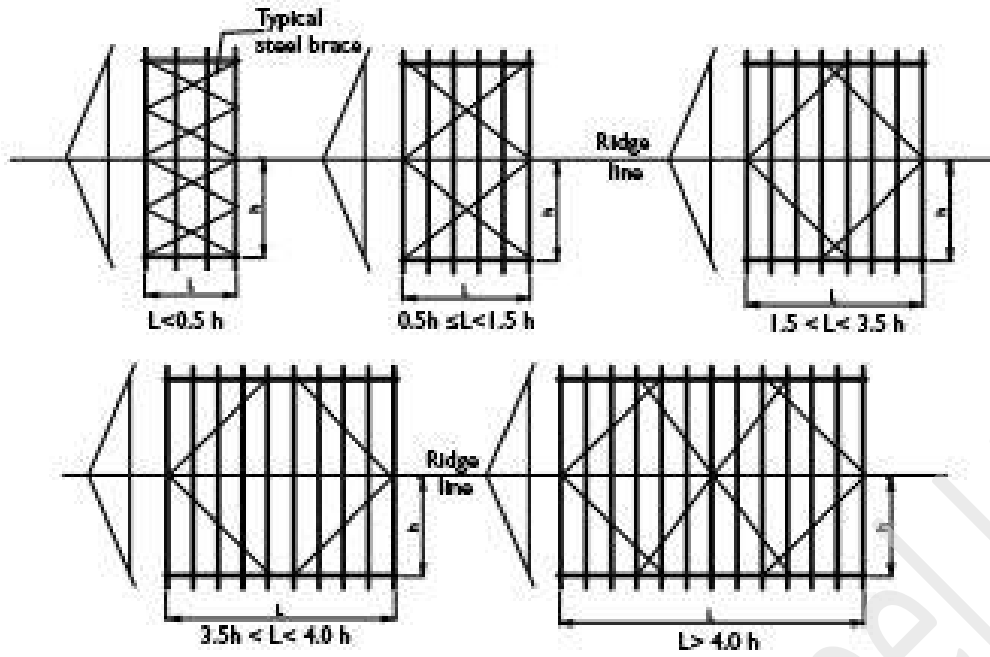

Truss Spans over 8m and up to 13m

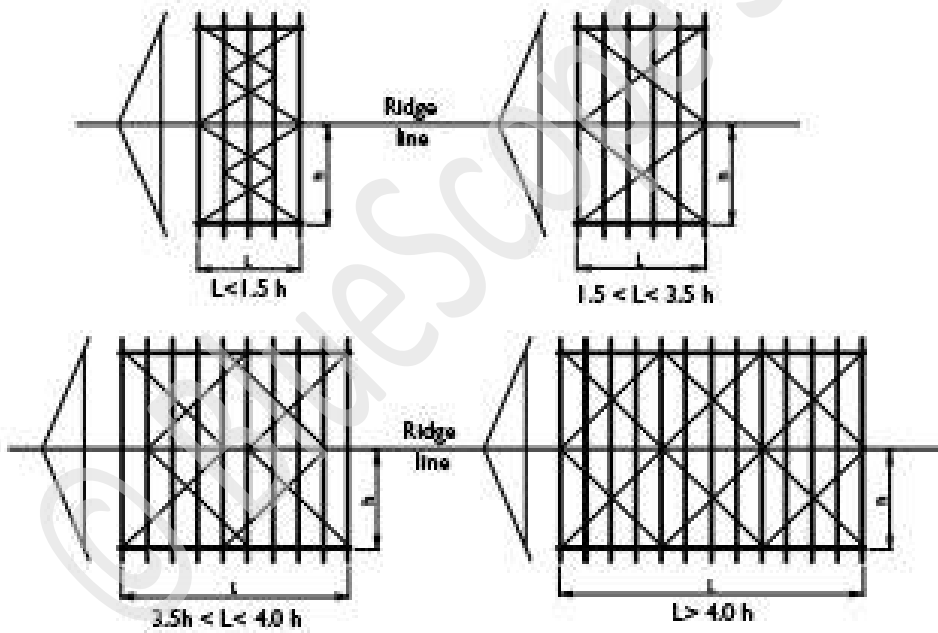

Choose the appropriate bracing pattern based on the size and shape of the roof.

Figure 7.87 Truss Spans 8 to 13m

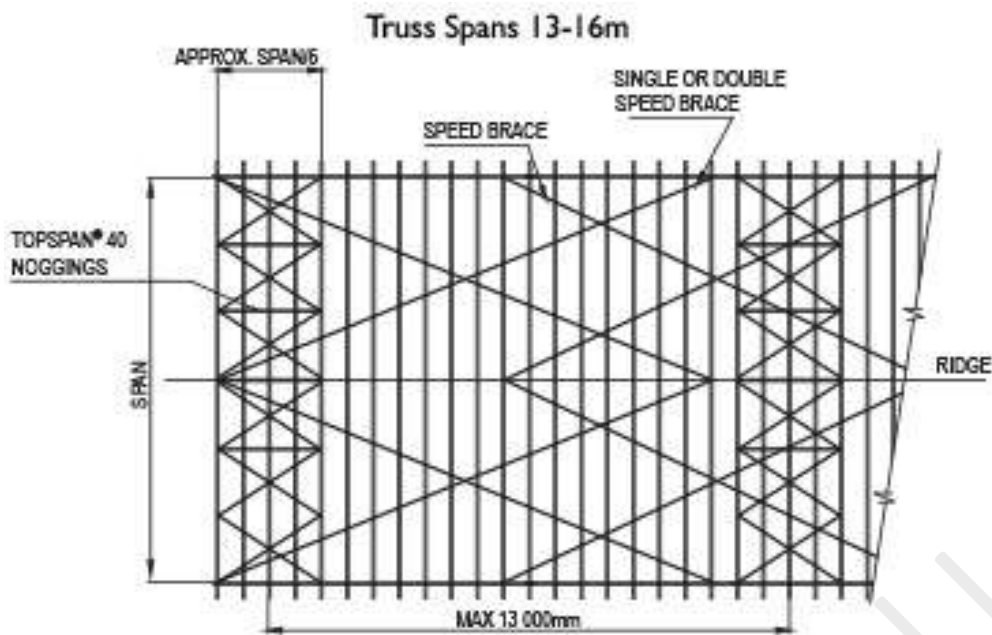

Figure 7.88 Truss Spans 13 - 16m

7.9.2.4 Hip Roof

For roofs with hip zone, the hip rafter serves as bracing and no additional top chord bracing is required in this zone.

If the portion of the roof between the hip end or Dutch-hip ends (L) is greater than half span of roof truss (h), then the roof shall be braced as per gable roof.

Roof length $L >$ half-span of roof truss, h .

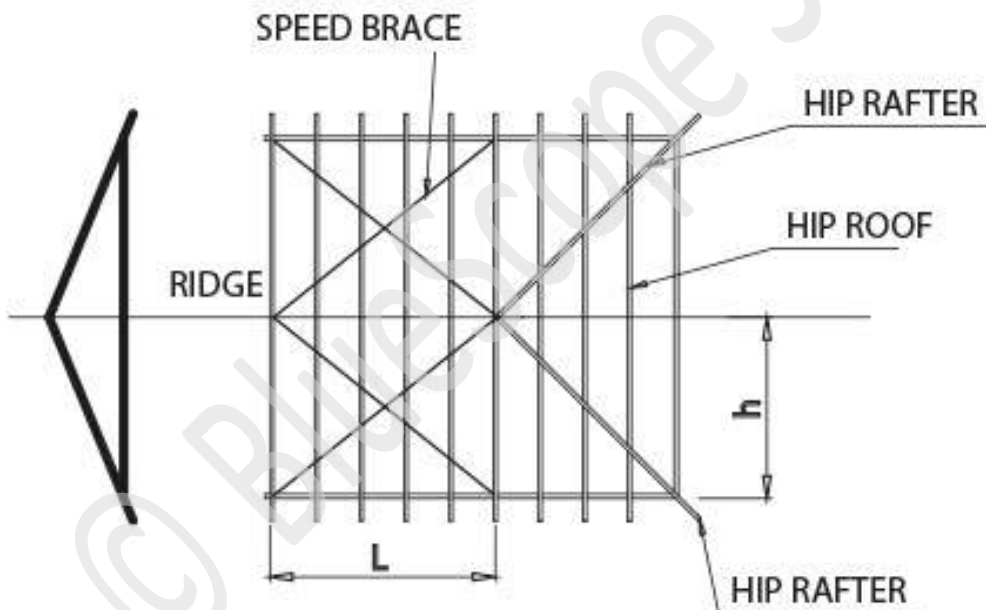
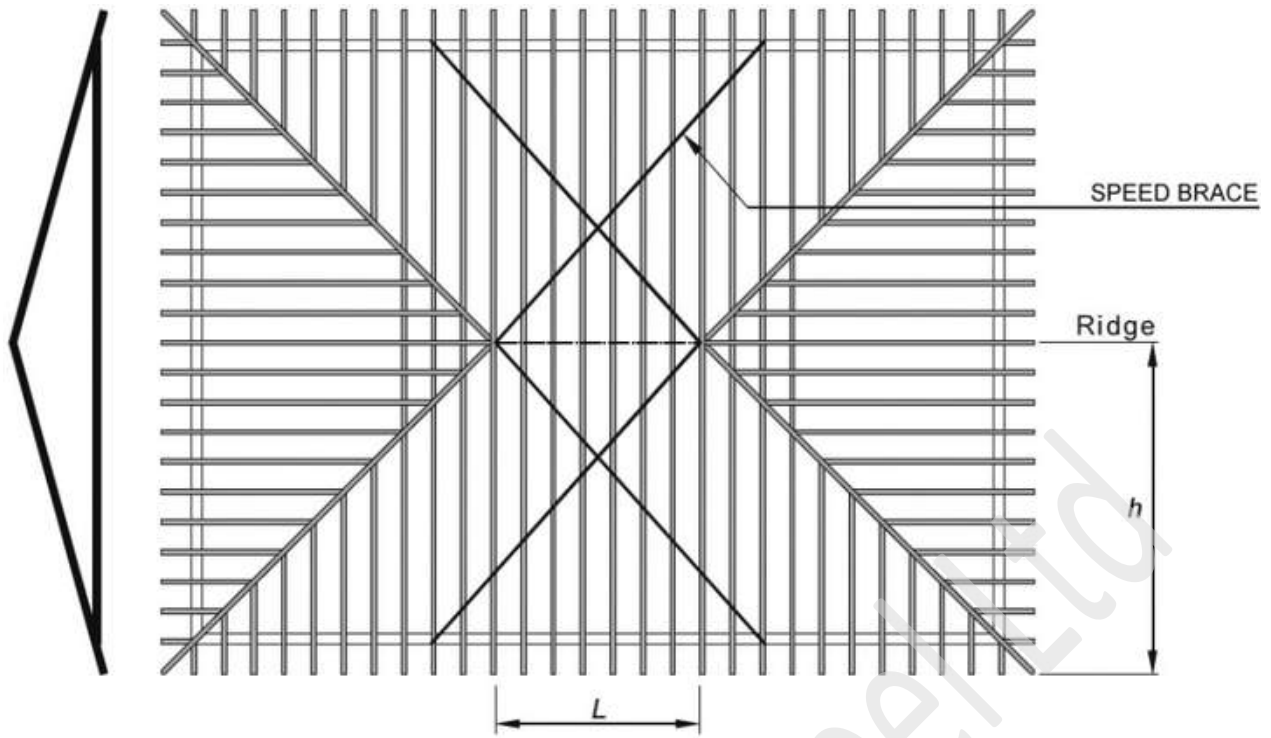

Figure 7.89 Roof length $L >$ half-span of roof truss, h

Truss Spans up to 8m Truss Spans over 8m and up to 13m Ridge

Figure 7.90 Roof length $L <$ half-span of roof truss, h



7.9.2.5 Dual Pitched Roof

On dual-pitched or cut-off roofs where the ridge line is not central on the building, each side of the ridge shall be considered as a separate case and gable end details shall be applied.

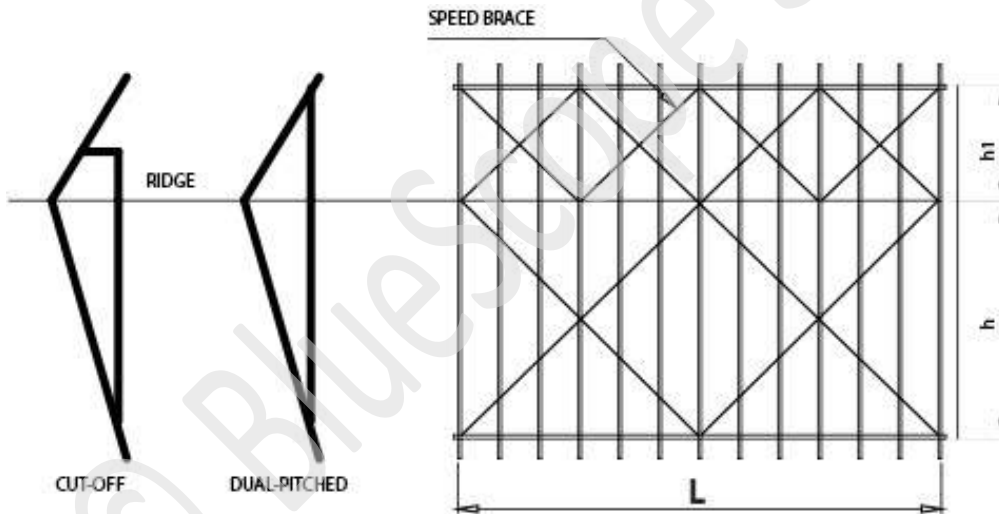

Figure 7.91

7.9.2.6 Bell Roof

For bell trusses, the speed brace should be spliced at the bell breaks as shown below. Refer to **Figure 7.93** for typical steel brace splice detail.

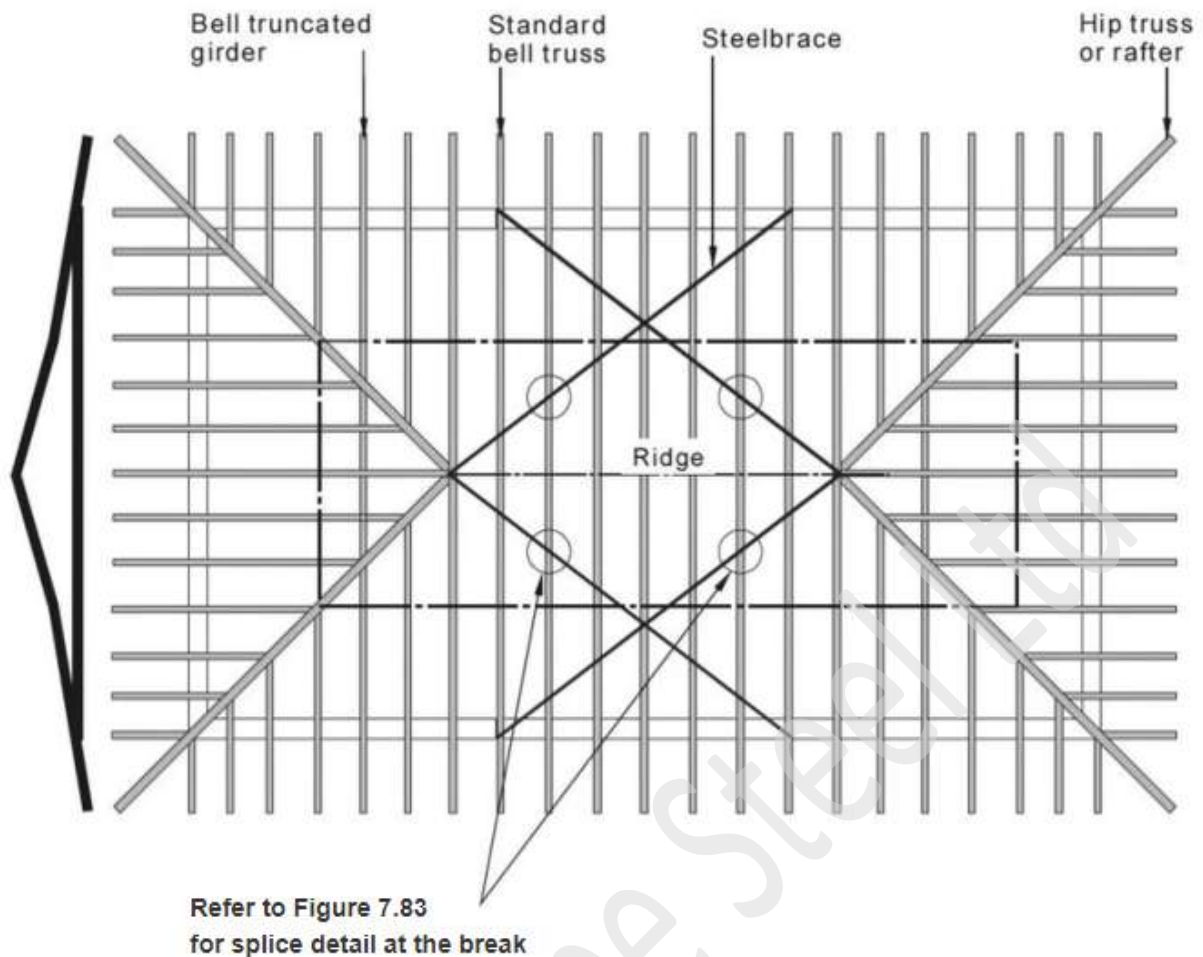

Figure 7.92

7.9.3 Bottom chord bracing

Bottom chord bracing is required to provide restraint to bottom chords of trusses when they are in compression due to wind uplift. Where ceiling battens are mechanically fixed to the bottom chord of trusses, using screw fasteners the ceiling battens (along with ceiling sheeting) provide adequate bottom chord bracing.

For suspended ceilings, clip on battens or exposed bottom chords where ceiling battens do not provide lateral restraint, bottom chord ties shall be provided.

Bottom Chord bracing consists of bottom chord ties and diagonal bracing.

Bottom chord ties may be roof battens or truss chord material (Minimum TOPSPAN® 22) fixed to each at spacing specified by roof designer and used in the truss design. The diagonal bracing may be minimum 32 x 1.2 strap brace fixed at each end in accordance with the bracing layout, tensioned and then fixed to each intermediate truss bottom chord. Refer to **Figures 7.81** and **7.83** for details and numbers of screws.

Ties and bracing to be fixed to supporting walls to transfer bracing loads to the structure.

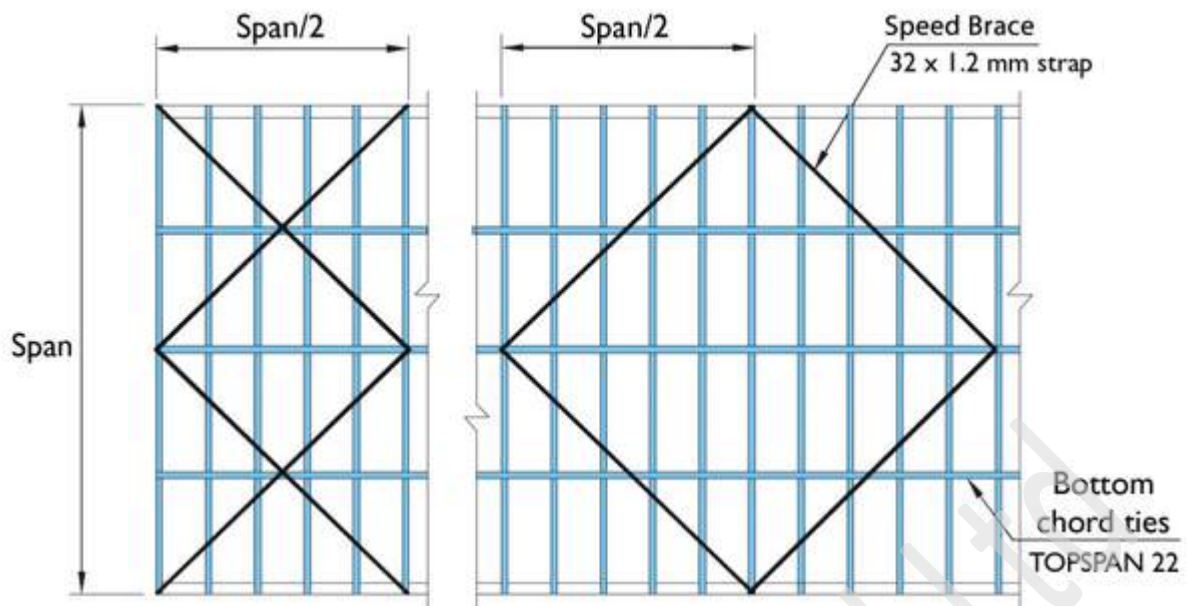

Figure. 7.93 Typical bottom chord ties bracing layout

7.9.4 Web bracing

The slenderness and capacity of web members of longer lengths can be enhanced by boxing of sections or by providing lateral restraints. The lateral restraint extends out at right angles to the plane of the truss and along the building and is braced back to the ceiling on roof plane at each end of building. **Figure 7.94** shows ties which are suitable for cases when trusses are parallel to each other and webs of trusses line up. A web rail is suitable when trusses are parallel to each other but the webs do not line up, as illustrated in **Figure 7.95**.

Web rails are usually 75 x 38 x 1.0mm or 90 x 38 x 1.0mm channel and the lateral ties are usually specified as TOPSPAN® 40. The Trained Software User will advise if lateral bracing is required. Typical web rail and lateral ties fixing details are shown in **Figure 7.96**.

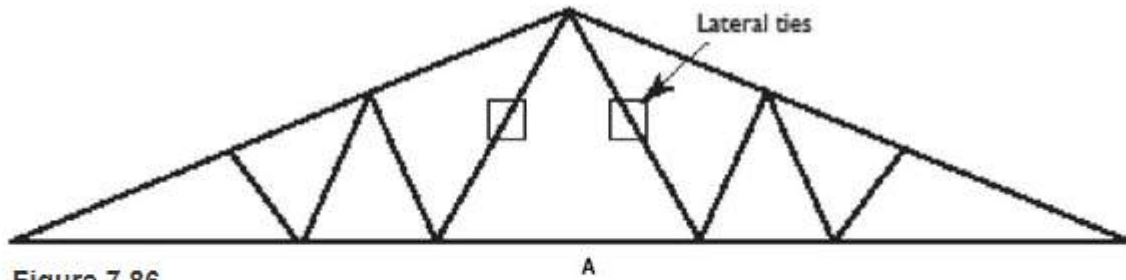

Figure 7.86

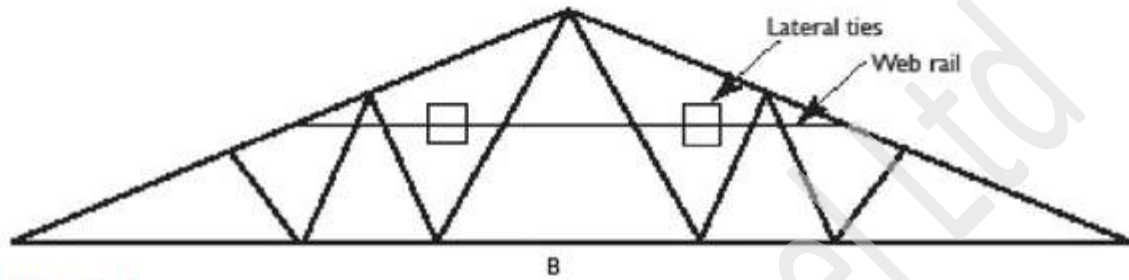

Figure 7.87

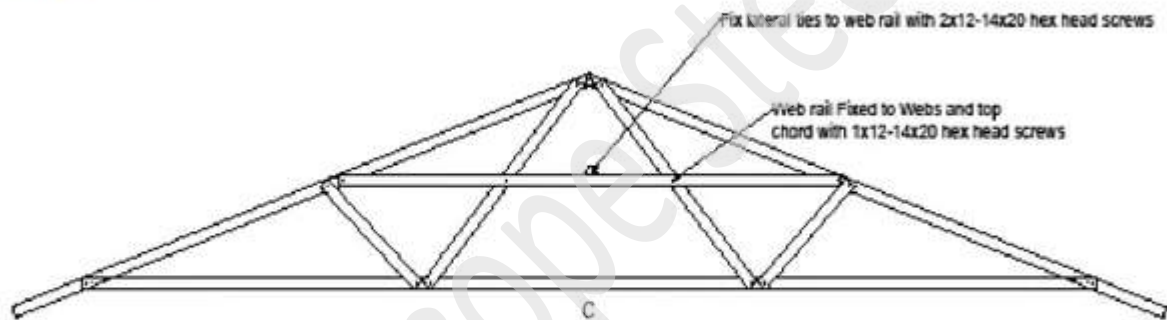

Figure 7.88

7.10 Battens

7.10.1 Ceiling battens and plasterboard angles

Ceiling battens must be fitted immediately after the roof trusses have been installed. By fixing the ceiling battens at this stage the roof trusses will be laterally restrained without the need of bottom chord ties.

Step 1: When all trusses are erected, install ceiling battens to the underside of the bottom chords. Ceiling battens can be spaced at 600mm centres or 450mm centres depending on the type of plasterboard that will be used for the ceiling (check the specifications). Ceiling batten sizes shall be selected from batten manufacturer's technical literature and sized to suit span, spacings and loads.

Note: Ceiling battens spacing is dependent on ceiling lining. For suspended ceilings, lateral restraints must be provided at spacings specified by the building designer.

Step 2: Fix the ceiling battens with two #10-16x16mm hex head self drilling screws, one into each flange of the batten into the bottom chord of the truss.

Step 3: Plasterboard angle must be used at the intersection of the ceiling batten/load bearing wall junction to support the ends of the ceiling battens.

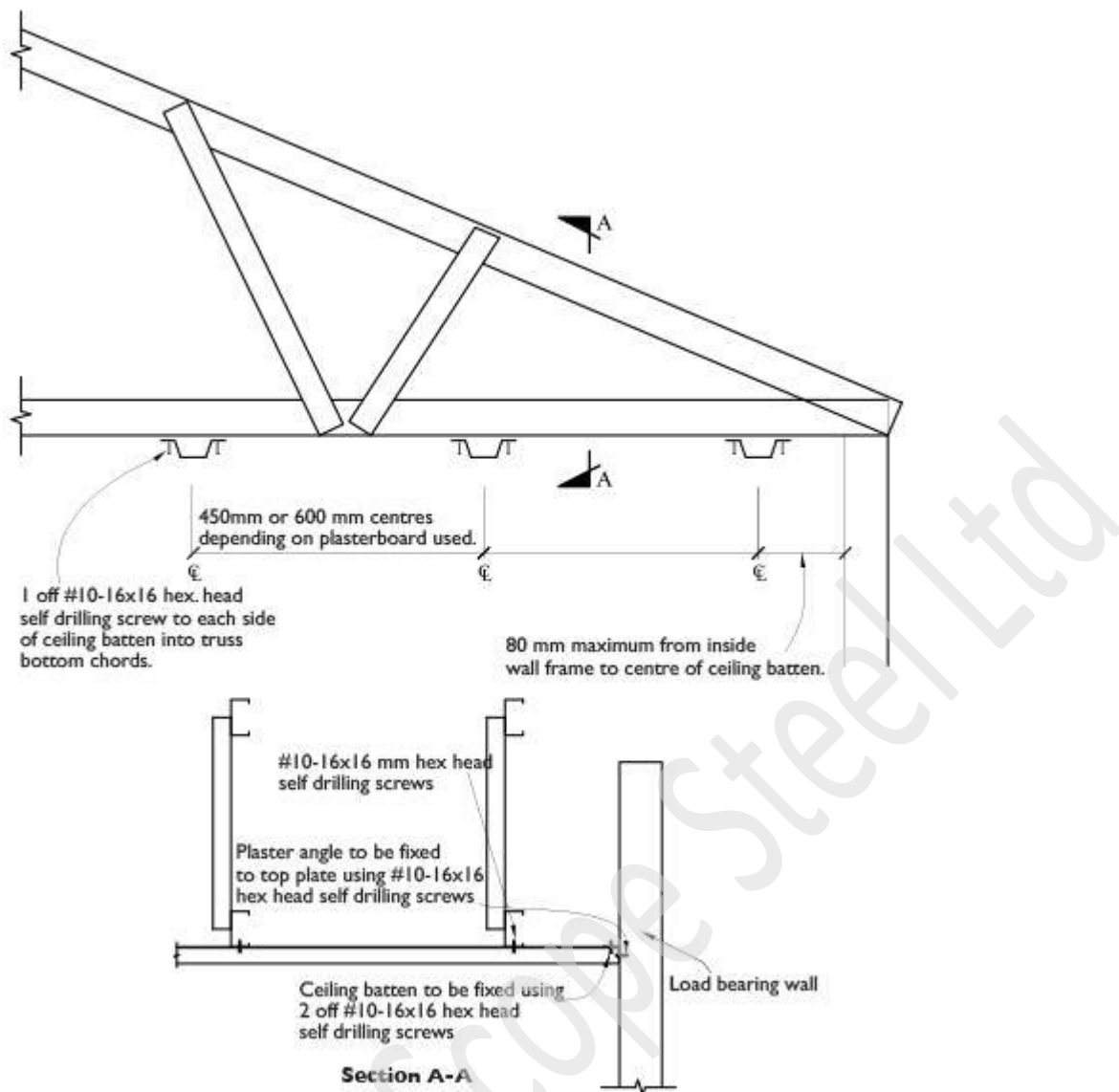
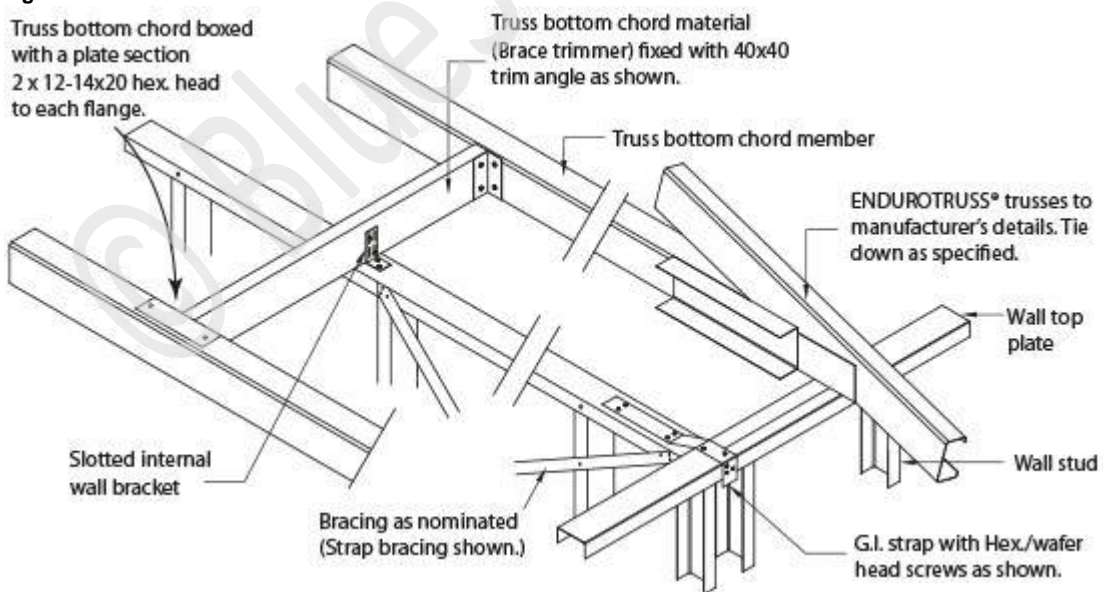

Figure 7.97

Truss bottom chord boxed with a plate section 2 x 12-14x20 hex. head to each flange.



7.10.2 Internal wall support and shear transfer

Figure 7.98 Transfer of Racking Loads to Internal Bracing Walls - Internal Wall Parallel to Trusses

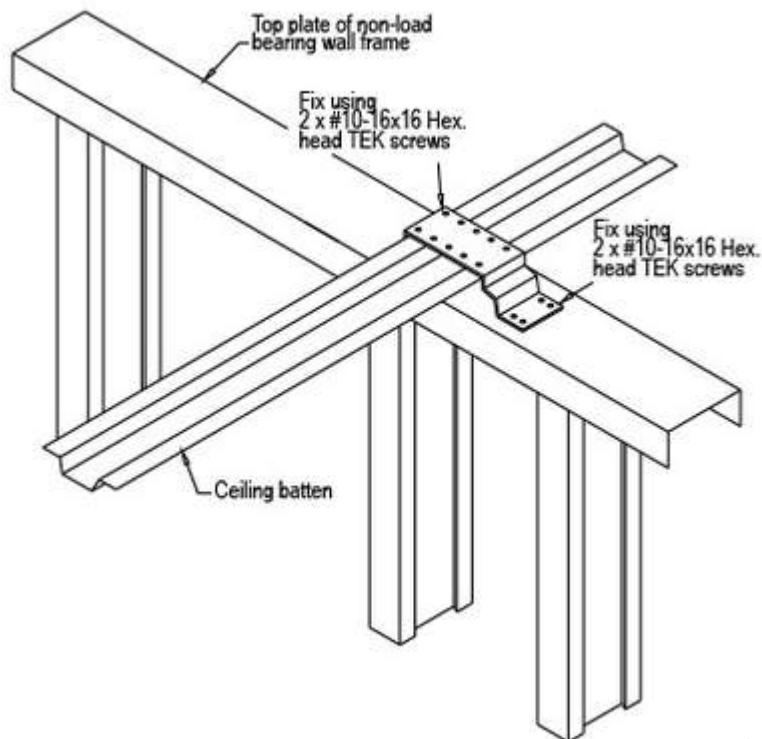

It is important that the truss can move up and down in this bracket so screws should be able to slide. To enable the trusses to slide ensure the fastener is placed in the middle of the slot and it is not over tightened.

For shear transfer, refer to Wall Installation manual.

Step 4: Fix one #10-16x16mm hex head self drilling screw down through the top of the bracket and into the top of the ceiling batten to stop the bracket sliding.

Step 5: Bend the bracket down to the top plate of the internal wall and fix two #10-16x16mm hex head self drilling screws through the foot of the bracket into the top plate.

Refer to Figure 7.97

Step 6: Install hitch brackets to the bottom chord of trusses at a maximum of 1200mm centres. Fix two #10-16x16mm hex head self drilling screws into the side of the flat face of the bottom chord.

Step 7: Now fix two #10-16x16mm hex head self drilling screws through the foot of the bracket into the top plate.

Refer to Figure 7.98

7.10.3 Roof battens and spacings

The bracing of top chords is achieved via the overlying roof battens. Ensure roof batten spacings and fixings provide the restraint assumed in the truss design.

Step 1: Maximum roof batten spacing is specified by the user in ENDUROCAD® and shown on the output documentation. Batten spacings are usually defined in sheet manufacturer's tables. Batten spacing of 900mm batten centres should be used unless otherwise specified for sheet roofs. Ensure both spacings do not exceed the maximum used by the Trained Software User in the design. Roof batten sizes shall be selected from the manufacturer's technical literature and sized to suit span, spacing and loads.

Step 2: Fix roof battens to trusses using #10-16x16mm hex head self drilling screws, to both batten flanges at each truss. Roof battens shall be fixed to every truss, including each ply of girder truss.

Note: For roofing fix a roof batten each side of the line formed from the intersection of the jack rafters and the chords of the truncated trusses to finish the hip roof line. Use two #12-14x20mm hex head self drilling screws at each intersection.

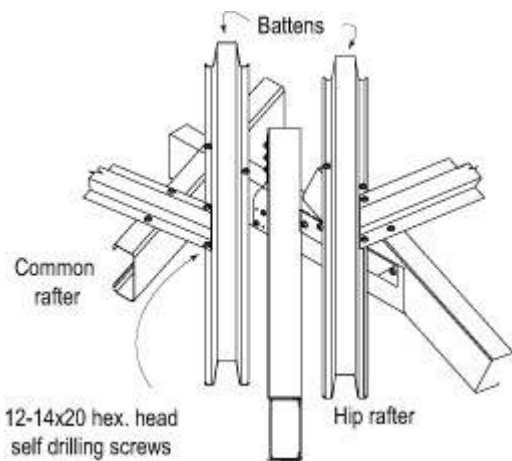

Figure 7.99 Hip rafter and batten arrangement

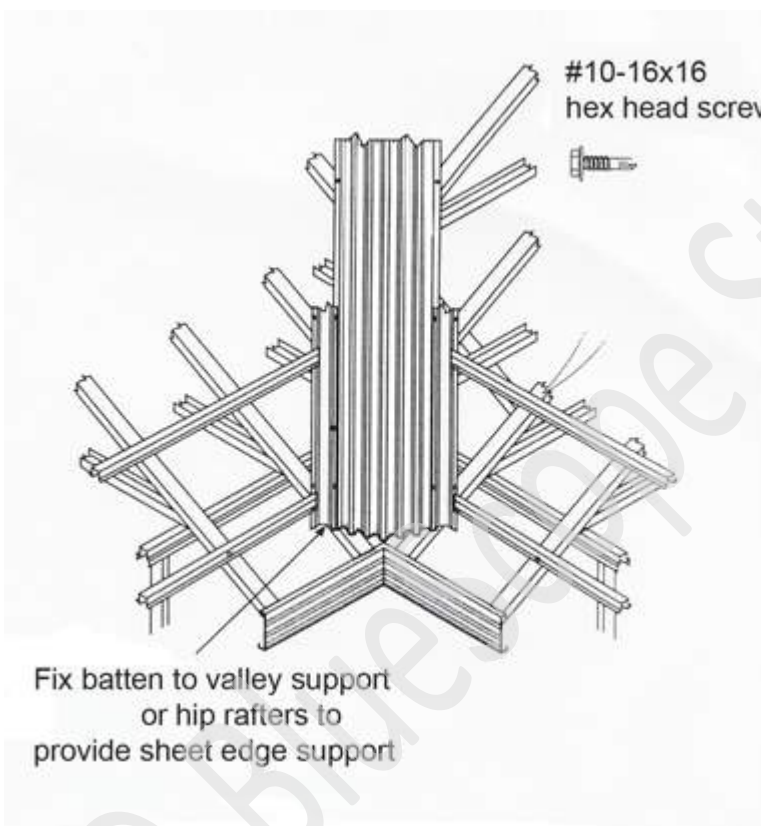













Figure 7.100 Valley gutter arrangement

7.11 Fasteners



Important: Please note equivalent fasteners may be used to those listed below. All fasteners shall be min. AS3566.2 Class 3 with the exception that class 4 fasteners should be used at less than 400m from high water mark of surf or exposed salt marine influences. Do not use stainless steel fasteners with steel framing made from TRUECORE® steel.

Where a manufacturer is listed, alternative products may be used providing all corrosion and mechanical properties are the same as those supplied by the specified manufacturer and in compliance with AS3566.2 Class 3. All screws shall have shear and pull out values at least equivalent to those shown in the ENDUROFRAME® Design Manual. Product specifications from fastener suppliers may change from time-to-time so please check the latest technical data sheets from fastener suppliers to ensure that corrosion and mechanical properties comply with the values required for the ENDUROFRAME® system.

Fasteners used should comply with the mechanical properties specified in the ENDUROFRAME® Design Manual. The fasteners below are suitable for fixing structural steel frames together, as specified below:

Description	Uses
 <p>5/16" -12x17 hex head #17-15x15 hex head with trilobular thread forms</p>	Structural connections on trusses
 <p>12-14x20mm hex. head self drilling screw</p>	Structural fixing screw, tiles roof truss fixing, girder/truss heel bracket fixing, roof
 <p>10-16x16mm Wafer head self drilling screws</p>	Flush fixing screw where flush surface finish is required, e.g. Plasterboard® corner angles
 <p>M6.5 -12 x 42 hex head self drilling screw</p>	Fixing common rafters to truncated truss top chords
 <p>14-10x20mm hex head</p>	Structural fixing screw low wind area
 <p>6-20x50mm CSK wing self drilling screws</p>	Architraves, reveals and skirtings General finishing and fixing timber screw
 <p>6-20x65mm CSK self drilling screws</p>	Architraves, reveals and skirtings General finishing and fixing timber screw
 <p>8-18x30mm bugle needle point self drilling screws</p>	Plasterboard fixing to ceiling battens
 <p>6-20x25mm bugle drill point self drilling screws</p>	Plasterboard fixing to wall frame studs
 <p>8-18x25 SEH extended point self drilling screws</p>	Fibrous cement fixing screw (wet areas)
 <p>M6 x 1P x 18mm Smooth Top Gx Teks Frame Screw</p>	Stiffening stud to plate connections, connecting lintels to plates, and attaching bracing

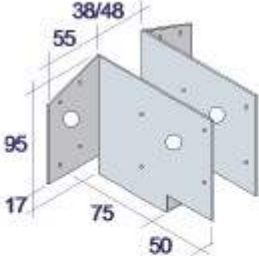
7.12 Components

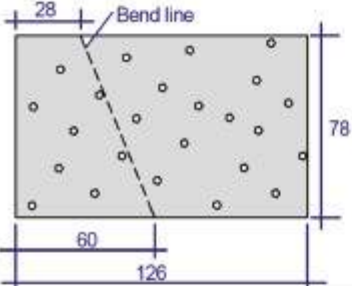
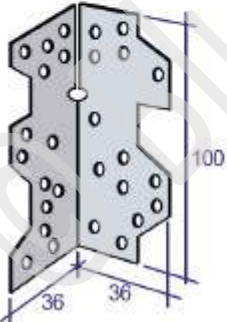
Picture	Description	Application	Supplier
	Bridge Truss Boot TBJ45 1.8mm BMT Zincform G450 Z275	Z275 Bridge Truss Boot	Pryda
	CPAH Hold down bracket 1.9mm BMT Zincform G450 Z275	Hold down bracket	Pryda
	Hip Mitre Plate 1.9mm BMT Zincform G450 Z275	Hip Mitre Plate	Pryda
	Triple Grip (left or right hand) 1.8mm BMT Zincform G450 Z275	Tie Down	Pryda
	MultiGrip	Tie Down	Pryda

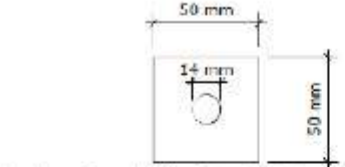
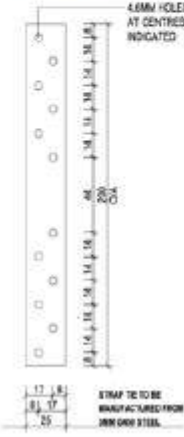
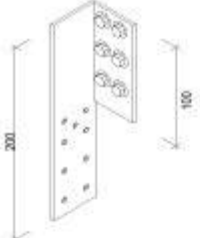
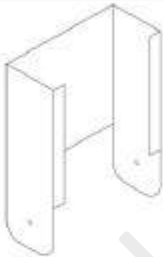
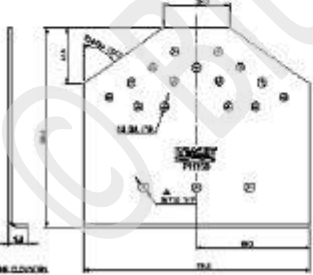
Picture	Description	Application	Supplier
 <p>Washer - 5mm thick galvanized steel</p>	50 x 50mm Square Galvanized Washer	Washer For Tie Down	General
	25 x 3 x 200mm Steel Tie-Down Strap	Combination Heel and Truss Tie-Down Plate	
	50 x 50 x 3 x 200mm Notch Equal Angle Tie-Down-Left and Right	Combination Heel and Truss Tie-Down Plate	
	Transition Section Connection	Truss Tie-Down	ENDUROFRAME
	Apex Plate	Type C Apex	ENDUROFRAME

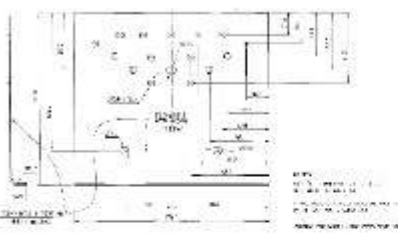
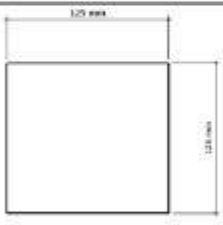
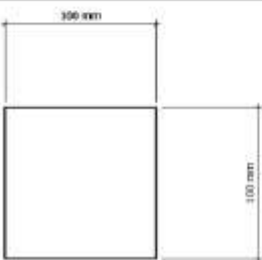
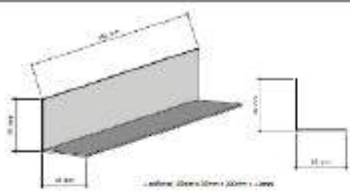
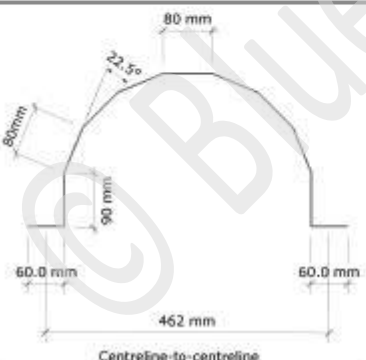
Picture	Description	Application	Supplier
	25 x 3 x 200mm Steel Tie-Down Strap	Elbow Bracket	Pryda
	Heel and Knee Stiffening Plate 125x125x1.5 for 90mm System	Heel and Knee Stiffening Plate	Pryda
	Heel and Knee Stiffening Plate 100x100x1.5 for 75mm System	Heel and Knee Stiffening Plate	ENDUROFRAME
	Knee Stiffener For Type C 35mm x 35mm x 200mm x 1.0mm		
	Angle lintel - 200 x 35 x 1.5mm Galvanized Section Minimum 90mm Long	Truss Web Stiffener	
	All holes are in center of the barrel and are located 37.5mm from the end for a C75 truss or 45mm for a C90 truss. Height 300, thickness 1.5 mm material.		

8.0 Definitions of terms

Gable ladder: A pre-fabricated panel used to form a gable overhang.

Common Rafter: A member on a hip end supported by truncated trusses and supporting roof battens.

Creep Rafter: A member on a hip end supported by the hip rafter and end wall supporting roof battens.

Hip Rafter: A prefabricated member from channel section running down the hip ridges supporting creep rafters and battens.

Whaling Plate: A length of chord section fixed to the outside face of a dutch gable truss to support common rafters.

Bridge Bracket: Connects a bridge truss to a girder truss.

Wind Bracing: Bracing fitted diagonally over the roof plane from the top plate to the ridge line to transfer bracing loads in to the supporting structure.

Bottom Chord Tie: A section fixed at right angles to the bottom chord to provide lateral restraint.

Temporary Braces: Structural sections used to brace trusses in position before the application of permanent bracing. Temporary bracing must be fastened for solid support.

Bottom Chord Tie: A section fixed at right angles to the bottom chord to provide lateral restraint.

Bracing Strap: Light-gauge metal strap 25x1 used to brace roof frames. Two straps diagonally opposed on one plane form one brace.

Bracing- Roof: Bracing fitted diagonally over a roof plane from the top plate to the ridge line to transfer bracing loads in to the supporting structure.

Bracing Wall: Component fixed to the face of a wall panel to provide shear strength in the plane of the wall. Bracing may be Strap, Panel or K type.

Chords: Steel components forming the external perimeter of a truss.

Cladding: Wall or roof lining- Covering to structural frame to provide weather protection to the building.

Dutch Gable (Dutch Hip): A block end type where the rafter face is truncated by a vertical face some distance back from the hip end pitching line.

Eave Block: A block outside the building pitching perimeter defining the extent of rafter or truss top chord extension past the pitching line

Gridlines: A series of equal spaced vertical and horizontal reference lines with origin at the building Start point. They offset in both polar directions towards the 2 ends of the building. Grid-lines may form the basis of stud-spacing, truss spacing or wall cladding joint location.

Heel: The truss connection at an end support point.

Hip Line: The interface between block faces where the difference between the 2 adjoining block top faces is more than 180 degrees

Load Bearing Wall: A wall which carries vertical loads from the construction above and or lateral loads resulting from the wind. Internal or external walls may be load bearing.

Non-Load Bearing walls: Internal walls which do not support roof or floor loads are considered non load-bearing. However Internal walls may be used as lateral bracing walls and are required to resist internal wind pressures.

Panel Point: The connection point of a truss web to a chord.

Pitching line: The external perimeter of a buildings roof. It is the intersection between the bottom of a truss bottom chord and the bottom of a truss top chord or for cut off or half trusses of the bottom chord and the external face of the end chord. It is often aligned with the external face of an external wall.

Rafter Crown: A rafter positioned at the centre of a standard hip face running from the intersection point of the hip lines to the outside edge of the eave block.

Rafter Face: A top face of a roof block whose battens are supported by rafters. Standard faces are triangular and extend over the entire width of a rectangular block end.

Rafters - Creeper: Rafters positioned in a hip that are not supported by trusses but by hip rafters, load bearing walls or fascias only.

Rafters - Common: Rafters positioned in standard locations extending from hip rafter to fascia supported by truncated trusses.

Rafters - Hip: Hip rafters provide rafter and batten support at the edge of a rafter face where the difference between the 2 adjoining block top faces is more than 180 degrees.

Rafters - Valley: Valley rafters provide rafter and batten support at the edge of a rafter face where the difference between the 2 adjoining block top faces is less than 180 degrees.

Ridge: The interface between two block faces where the difference between the 2 adjoining block top faces is more than 180 degrees.

Shear wall: This is the structural system consisting of flat tensile braces, studs and hold-down connectors. It is used to resist racking loads and is discretely placed within a wall panel to transfer racking loads to the foundation. Wall breakpoints should NOT be placed within the location of a shear wall brace.

Soffit: The finished underside of a roof overhang or porch ceiling that covers the rafter bottoms or eaves.

Truss Station: In a Hip end the truss station is its position from the hip end pitching line expressed in terms of mm or truss spans. eg where trusses are spaced at 600mm centres the first or 600mm station truss is placed 600mm from the hip end pitching line.

Valley End: A combination of Girder Truss supporting bridge trusses in an adjoining roof block and Saddle trusses forming the ridge line between the 2 blocks.

Valley Line: The interface between two block faces where the difference between the 2 adjoining block top faces is less than 180 degrees.

Webs: Steel Members that join the top and bottom chords of a roof or floor Truss, which form triangular patterns usually carrying tension or compression forces.

Trained Software User: A person who has been through a structured training program under the supervision of an approved trainer. That person must hold a current certificate from BlueScope Steel stating they are qualified to design and detail residential structures, utilising the ENDUROCAD® software, which are fit for manufacture and erection.

9.0 References

AS4055: 2011 Wind Loads for Housing

AS4440: 2004 Installation of nail plated timber roof trusses

AS3566.1: 2002 Self-drilling screws for the building and construction industries

NASH Handbook Low Steel Framing, National Association of Steel Framed Housing 2011

NASH Standard - Residential and Low Rise Steel Framing: Part 1, Design Criteria, National Association of Steel Framed Housing 2005

AS1397:2011 Steel sheet and strip - Hot-dipped zinc-coated or aluminium/zinc-coated - Continuous hot-dip metallic coated steel sheet and strip - Coatings of aluminium, zinc and magnesium

Disclaimer, warranties and limitation of liability

This publication is intended to be an aid for all trades and professionals involved with specifying and installing ENDUROTRUSS® products and not to be a substitute for professional judgement.

Except to the extent to which liability may not lawfully be excluded or limited, BlueScope Steel Limited will not be under or incur any liability to you for any direct or indirect loss or damage (including, without limitation, consequential loss or damage such as loss of profit or anticipated profit, loss of use, damage to goodwill and loss due to delay) however caused (including, without limitation, breach of contract, negligence and/or breach of statute), which you may suffer or incur in connection with this publication.

© Copyright BlueScope Steel Limited 27 April 2016

Information, brochures and your local distributor:

www.enduroframe.com

BLUESCOPE, TOPSPAN, TRUECORE ENDUROFRAME, ENDUROTRUSS, ENDUROCADD and ENDURO are all registered trademarks of BlueScope Steel Limited, ABN 16 000 011 058. Pryda®, BattenZip® and Tek® are registered trademarks of ITW Australia Pty Ltd.

© BlueScope Steel Ltd