

# ENDURO FRAME<sup>®</sup>

## ENDUROTRUSS<sup>®</sup> Roof System Installation Manual



The smart, simple solution to roof framing.



# ENDUROTRUSS Roofing System Installation Manual

- 1.0 Scope of manual
- 2.0 On-site handling
  - 2.1 Slings
  - 2.2 Roof trusses exposure and storage
- 3.0 Tools & equipment
- 4.0 Points for construction
- 5.0 Truss identification
- 6.0 Truss Assembly
  - 6.1 ENDUROTRUSS® Framing System marking and branding
  - 6.2 Chord to chord connection identification
  - 6.3 Fasteners
  - 6.4 ENDUROTRUSS® Framing System assembly
  - 6.5 ENDUROTRUSS® splicing
    - 6.5.1 Splicing of Boxed Chords
    - 6.5.2 Splicing Boxed Chords
  - 6.6 ENDUROTRUSS® Framing System stiffening and re-inforcement
    - 6.6.1 Web stiffening
    - 6.6.2 Apex stiffening
    - 6.6.3 Heel Stiffening
    - 6.6.4 Knee Stiffening
    - 6.6.5 Web Stiffening
    - 6.6.6 Chord Boxing
    - 6.6.7 Web Boxing
    - 6.6.8 Web Supports
    - 6.6.9 Elbow Stiffening
  - 6.7 Boxed Eaves
  - 6.8 Pre-attaching ENDUROGRIP tiedown brackets to truss bottom chords
- 7.0 Roof construction
  - 7.1 General and design
    - 7.1.1 Prior to construction
    - 7.1.2 Trusses above Internal load bearing walls
    - 7.1.3 Fasteners
  - 7.2 Roof truss set-out
  - 7.3 Gable End Construction
    - 7.3.1 Flush Gable
      - 7.3.1.1 Supporting flush gables with gable end trusses
      - 7.3.1.1 Supporting flush gables with raking walls
    - 7.3.2 Outriggers
      - 7.3.2.1 Assembling outriggers
      - 7.3.2.2 Installing outriggers
    - 7.3.3 Gable ladders
      - 7.3.3.1 Assembling gable ladders
      - 7.3.3.2 Installing gable ladders
  - 7.4 Hip End Construction
    - 7.4.1 Type 1 Hip construction
    - 7.4.2 Connecting Common Rafters in Type 1 Hip End
    - 7.4.3 Type 1A Hip construction
    - 7.4.4 Type 2 Hip Construction
    - 7.4.5 Hip Rafter Construction
      - 7.4.5.1 Boxed Hip Rafters
      - 7.4.5.2 Veed Hip Rafters

- 7.4.5.3 Hip Truss
    - 7.4.6 Common Rafters on Dutch Gables
    - 7.4.7 Crown Rafters
    - 7.4.8 Creeper Rafters
  - 7.5 Dutch gable construction
  - 7.6 Valley end construction
    - 7.6.1 Girder-bridge truss connection
    - 7.6.2 Assembling Bridge Trusses
    - 7.6.3 Installing Bridge Trusses onto Girder Trusses
    - 7.6.4 Saddle truss construction
    - 7.6.5 Valley Installation
    - 7.6.6 Radial Roof
  - 7.7 Common roof block construction
  - 7.8 Truss and Rafter Tie Down Connections
    - 7.8.1 Boxed Tie Downs
  - 7.9 Truss restraints
  - 7.10 Roof bracing
    - 7.10.1 Temporary bracing
      - 7.10.2.1 Fixings
      - 7.10.2.2 Bracing Layout
      - 7.10.2.3 Gable roof bracing layout
      - 7.10.2.6 Bell Roof
  - 7.11 Battens
    - 7.11.1 Ceiling battens and plasterboard angles
    - 7.11.3 Roof battens and spacings
  - 7.12 Fasteners
  - 7.13 Components
- 8.0 Definitions of terms
  - 9.0 References

# General notes to be read before you use this manual:

1. This Manual has been prepared for a range of roof framing designs using ENDUROTRUSS® building components manufactured or supplied by BlueScope Steel, its licensed manufacturers or dealers.
2. The ENDUROFRAME® Building System has been designed as a complete framing system.
3. All erection and connection details must be made in accordance with the relevant standard connection drawing details contained in either:
  - this manual or its supplements
  - drawings output from the ENDUROCADD® software.
4. Before commencement of any fabrication or construction develop a safety management plan to cover key risks. Key risks include, but are not limited to:
  - a. Working at heights
  - b. Electrical safety
  - c. Cuts and scratches
5. Consider and install the appropriate level of safety equipment to manage identified risks. Safety equipment that may be required includes:
  - a. Personal protective equipment including safety glasses, gloves, hearing protection (when using power tools) and sunscreen;
  - b. Appropriate fall protection equipment including guard rails, scaffolds, ladders, elevated platforms, safety mesh, and fall restraint harnesses
6. A temporary earth should be established during the construction of steel frames and, upon completion, the steel house frames must be permanently earthed in accordance with the requirements of local electricity authorities.
7. You should check with your local workplace health and safety authority to see what safety measures you need to put in place prior to and during construction. It is the responsibility of the installer/erector to ensure all local safe work practices are adhered to and the safety of the whole site is maintained at all times.
8. For wiring in steel wall frames, nylon grommets shall be installed to run electrical cables through.
9. Where insufficient detail is included in this manual for your project, seek specialist advice.
10. Before you commence construction:
  - a. You should check with your local government authority to see if any form of prior permission or approval is required;
  - b. If you want to build or construct any attached structure, you should seek advice from a suitably qualified engineer to verify the capacity of your existing structure to withstand any additional load arising from the attached structure. You should also check with your local government authority to determine any specific requirements for the attachment to existing structures;
  - c. You should check with your local workplace health and safety authority to see what safety measures you need to put in place prior to and during construction. It is the responsibility of the installer/erector to ensure all local safe work practices are adhered to and the safety of the whole site is maintained at all times.
  - d. Contact [info@enduroframe.com.au](mailto:info@enduroframe.com.au).
11. Refer to <http://www.truecore.com.au> for locations where the ENDUROFRAME® Building System can be warranted.
12. Read the Important disclaimer below.

## **Important disclaimer about this construction manual**

### **Date of Issue**

This manual was issued on September, 2014. BlueScope Steel may make changes to this Manual in its sole discretion. You should check you are using the current version of the Manual before you start construction. Refer to <http://www.enduroframe.com> to check version.

### **Conditions of Use**

If you use this manual, you acknowledge and agree that your use is subject to the terms and conditions in this manual. BlueScope Steel, its agents, officers, employees, subcontractors or consultants make no representations, either expressed or implied, as to the suitability of the information and data in this manual for your particular purposes. It's your responsibility to ensure the design you use is appropriate for your needs, the products you have purchased, your site and structural limitations and your building and construction capabilities. It is recommended that you obtain qualified expert advice.

### **Use of Genuine Materials**

Structures in this manual must only be built or constructed using those genuine ENDUROTRUSS® building components made from TRUECORE® steel and made with the ENDURO® rollformer or recommended third party products. Except as otherwise provided in these terms, any warranties only apply to you (if at all) if you use the genuine BlueScope Steel or recommended third party products and method of construction.

### **Check Delivery**

It is important that you check all materials delivered to site against your invoice before you use them in your building or construction to ensure all components have arrived, are of the appropriate quality and are ready for installation.

### **Limitation of Liability**

By using this manual, you accept the risks and responsibility for all losses, damages, costs and other consequences resulting directly or indirectly from using this manual. Except to the extent to which liability may not lawfully be excluded or limited,



BlueScope Steel will not be under or incur any liability to any person for any direct or indirect loss or damage (including, without limitation, consequential loss or damage such as loss of profit or anticipated profit, loss of use, damage to goodwill and loss due to delay) however caused (including, without limitation, breach of contract, negligence, breach of statute and/or in equity), which may be suffered or incurred in connection with this Manual.

All rights reserved. No part of this brochure may be reproduced, stored in a retrieval system, or transmitted in any form or by any means, electronic, mechanical, recording or otherwise, without written permission of BlueScope Steel Limited. ABN 16 000 011 058.

## 1.0 Scope of manual

This manual has been prepared for the construction of a trussed roof within the following parameters:

- Only ENDUROTRUSS® Framing System components made from TRUECORE® steel and made with the ENDURO® rollformer can be used
- Erection details cover construction for cyclonic and non-cyclonic buildings. (See Table below.)
- Other spacings may require additional engineering
- Trusses suitable for both sheet roof cladding and tiled construction.

This installation manual covers the installation according to the following wind classifications, roof types and truss spans.

**Table 1 - Wind categories covered by this installation manual**

Wind Classification	Truss Spacing	N1	N2	N3	C1	C2	C3	C4
Tiled Roof	600mm	Y	Y	Y	N	N	N	N
	900mm	Y	Y	Y	N	N	N	N
	1200mm	Y	Y	Y	N	N	N	N
Sheet Roof	600mm	Y	Y	Y	Y	Y	Y	Y
	900mm	Y	Y	Y	Y	Y	Y	Y
	1200mm	Y	Y	Y	N	N	N	N

**Y = yes N = no**

### ENDUROTRUSS® Product performance

The ENDUROTRUSS® Framing System has been designed in accordance with relevant Australian Standards and the requirements of the Building Code of Australia 2013.

The roof framing system will perform as specified by the ENDUROCAD® 2020 software output documentation if installed in accordance with the recommendations and details set down in this manual and related references.

This manual contains vital information. **PLEASE READ IT CAREFULLY.**

**For more information and technical support, contact:** [info@enduroframe.com.au](mailto:info@enduroframe.com.au)

### Maximum Design Gust Wind Speed (Vh) at Height (h)

Wind Classification	Maximum design gust wind speed (Vh)	
	Serviceability limit state (m/s) (Vh,s)	Ultimate limit state (m/s) (Vh,u)
N1	26	34
N2	26	40
N3	32	50
N4	39	61
N5	47	74
N6	55	86
C1	32	50
C2	39	61
C3	47	74
C4	55	86

Taken from AS4055-2012 Page 5 Table 2

### The ultimate roof framing solution

The ENDUROTRUSS® Framing System is your opportunity to gain the competitive edge in roof construction - with added peace of mind. It is a hassle-free and competitive system delivering a superb job without the need for specialist 'steel skilled' site labour.

**You benefit from:**

- ENDUROTRUSS® Framing System parts are unique, and the design is patented to keep you ahead
- On-site you receive exactly what you need — no wastage
- Just-in-time delivery means you get what you want — when you want it — and there is less likelihood of damage on site
- The ENDUROTRUSS® Framing System uses the ENDUROCAD® roof design software package, a sophisticated design and detailing package
- The ENDUROTRUSS® system is self locating eliminating the requirement for jigs to assemble even hip rafters have pre-punched holes to self-align with truncated trusses on site
- The ENDUROTRUSS® Framing System only requires fastening on one side which greatly speeds up assembly
- Trusses can either be factory or site assembled giving flexibility in delivery and installation of trusses
- Fully engineered and certified, light-weight steel roof framing
- Parts can be linked together which assists in finding and sorting components for assembly, or pre-cut for factory assembly off the rollformer
- Roof designs for most shapes of roof and ceilings
- All parts are inkjet marked making identification simple
- Easy site assembly that requires minimum skill
- The ENDUROTRUSS® system is installed similar to timber trusses making installation by timber crews simple, using standard timber brackets available for some connections;
- Available in back to back or in-line 'flush' format to reduce the volume on a truck when assembled
- Accurate dimensions

**The steel framing advantage**

Steel house framing has been well established in Australia for many years. Steel house frames and ENDUROTRUSS® roofing frames are safe and stable – above all:

- They don't rot or warp
- Geometrically complex trusses can be considered due to the self-jigging nature of the trusses
- They are light and easy to erect
- They provide you with very flat roof planes
- They are pre-cambered for straight ceiling lines
- They can be site assembled by people with minimal skill

**Who uses The ENDUROTRUSS® Framing System?**

Any builder who wants to deliver a quality job at a competitive price.

**How does the ENDUROTRUSS® Framing System work?**

The heart of the ENDUROTRUSS® Framing System is the patented steel truss which is computer designed and manufactured.

The computer system does everything from designing the framing, to supplying the documentation, to controlling the manufacturing equipment.

Simply give your drawings to an ENDUROTRUSS® Framing System Trained Software User and they will do the rest. We input your design data and computer-controlled roll-formers produce the required parts.

**How do you use ENDUROTRUSS®?**

Apart from the drawings and certification mentioned above, you get delivered to your building site the lengths of roll-formed section required for every truss (and the screws). There are no mistakes because the parts only fit one way, and all parts have identification marks printed directly onto the steel.

Before starting installation, carefully read this installation manual. Further information on fabricating and installation of the ENDUROTRUSS® Framing System can be obtained from videos which can be found at [www.enduroframe.com.au/building/assembly\\_and\\_installation\\_videos](http://www.enduroframe.com.au/building/assembly_and_installation_videos)

Fabrication check sheets and quality control sheets that demonstrate the quality control requirements for assembling the ENDUROTRUSS® system are available from your local ENDUROTRUSS® manufacturer or by contacting [info@enduroframe.com](mailto:info@enduroframe.com).

All installation shall be done in accordance with this manual.

**Framing System market difference  
Make the great leap forward**

Read the contents of this Installation Manual and discover how the ENDUROTRUSS® Framing System can work for you.

The ENDUROTRUSS® Framing System only requires fastening on one side which greatly speeds up the assembly process.

When designed and manufactured correctly, the trusses are certified to comply with the structural engineering software requirements of the BCA.

## 2.0 On-site handling

### 2.1 Slings

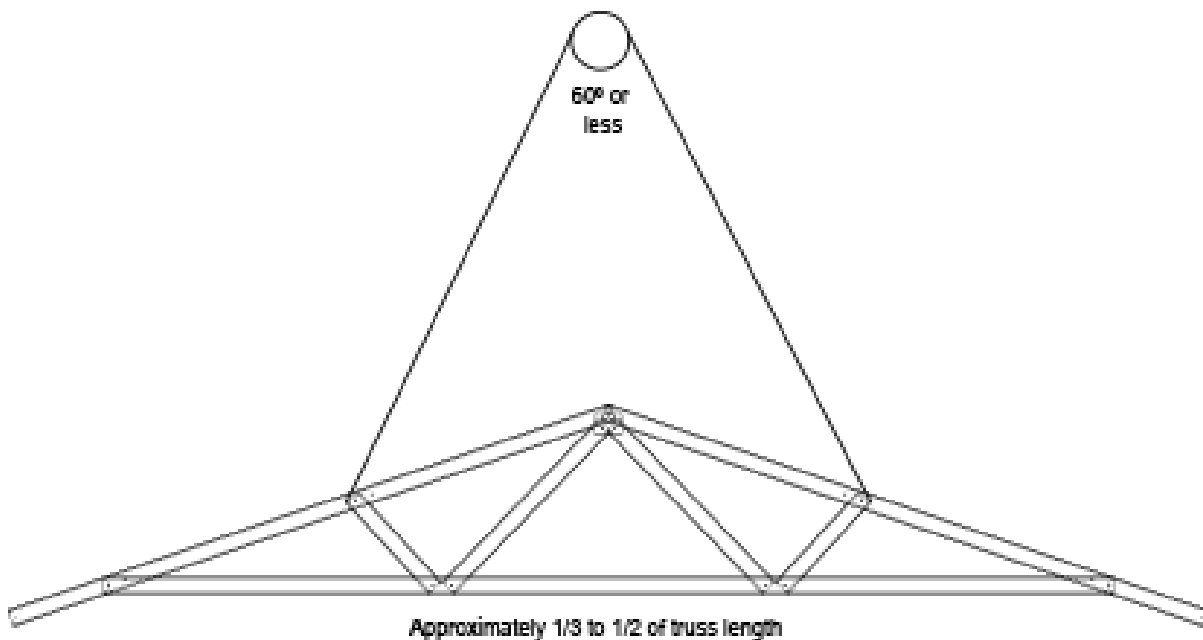
Trusses must be fully supported in either horizontal or vertical planes when being transported. Care must be taken when tying down and lifting trusses not to put an excessive pressure on chords, webs or joints. For transporting trusses in horizontal planes where a solitary Trusstite screw is used in a chord to web connection, an additional screw may be inserted to provide additional stiffness, especially for "flush" trusses.

Most trusses for single storey work may be lifted by hand, however where craneage is required, sling trusses or truss pieces from top chord panel points as shown in **Figure 2.1**. Slings should be located at equal distances from truss centre lines and be approximately one-third to one-half the truss length apart.

The angle between the sling legs should be 60 degrees or less and where truss spans are greater than 9000 mm, spreader bar should be used.

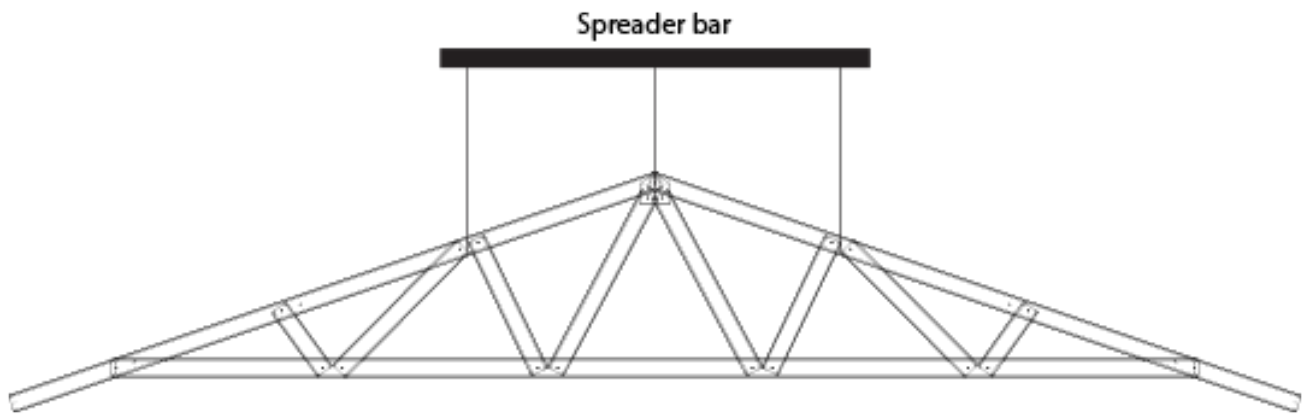
Where a truss span exceeds 9000 mm, a spreader bars with attachment to web-chord should be used. Never lift trusses by the apex joint alone.

**Note:** When manoeuvring any materials by hand, take care not to damage components. Components should be inspected on arrival to site. Damaged components may affect structural integrity.



< 9m

Approximately 1/3 to 1/2 of truss length Vertical lifting of trusses - Truss span greater than 9.0

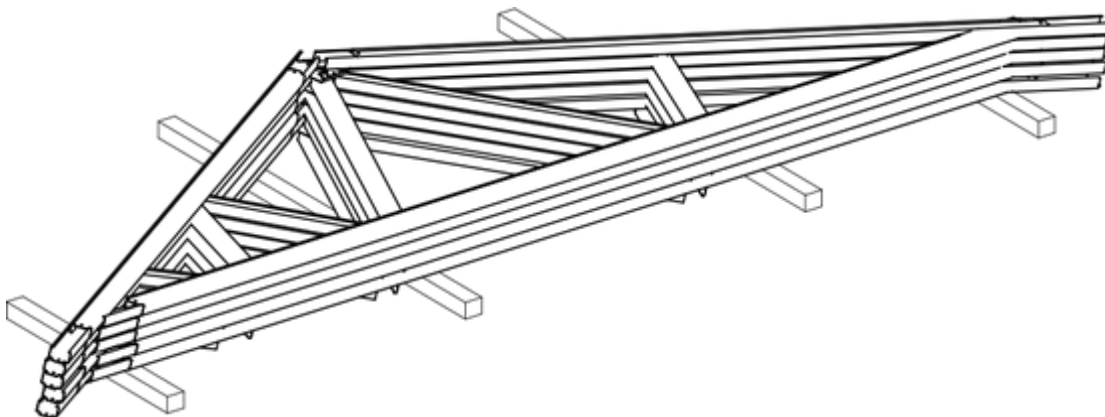


**Figure 2.1: Handling**

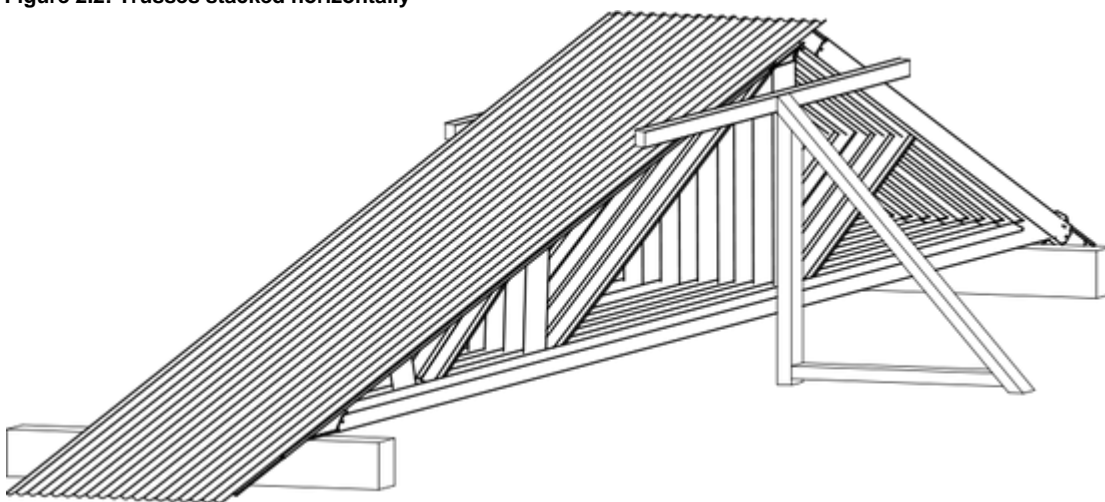
## 2.2 Roof trusses exposure and storage

Where trusses are stored on site, they should be blocked above firm ground so that they do not come into contact with the soil and to protect them from ground water:

1. If the trusses are stored horizontally, as shown in **Figure 2.2**, the blocking should be at 2.0m to 2.5m centres or as required at joints, to prevent bending of the trusses. Avoid using copper, chemically treated timber or EPDM based materials as blocking.
2. If the trusses are stored vertically as shown in **Figure 2.3**, they should be supported at the designed support locations or bottom chord panel points, and in a manner that will be prevented from tipping or toppling.
3. The truss chords should be sloped such that water drains off.



**Figure 2.2: Trusses stacked horizontally**



**Figure 2.3: Trusses stacked vertically**



## 3.0 Tools & equipment

### Required On-site Equipment

When erecting an ENDUROTRUSS® Framing System, the following tools and safety equipment may be required.

#### Power Tools

- screw gun
- metal cutting saw
- hand held metal cutting saw
- angle grinder

#### Tool Accessories

- 8mm (5/16") hexagon socket
- Magnetic nutsetter or extension bar (length up to 150mm)
- Suitable metal cutting blade
- 8mm spanner or socket

#### Hand Tools

- double action tin snips
- Locking sheet metal pliers
- spirit level preferably magnetic
- chalk line
- step ladder
- vice grips
- measuring tape

#### Essential Safety Equipment

- eye protection (safety goggles)
- hearing protection (when using power tools)
- protective gloves
- earth leakage circuit breaker for electrical goods
- all protection harness
- scaffolding, ladders, etc.



Angle grinder



Tin snips



Locking sheet metal pliers



**IRWIN.** [Compare](#)

Irwin Impact 5/16" x 100mm Magnetic Nutsetter

Magnetic nutsetter



**IRWIN.** [Compare](#)

Irwin 76-120mm Magnetic Screw Guide

Magnetic Screw Guide



Measuring tape



Screw gun



Hand held metal cutting saw

## 4.0 Points for construction

### Trusses must be installed plumb and straight

While erecting the roof, trusses must be fixed plumb and straight. After fixing, if a bow or tilt is evident, the trusses have not been installed correctly. In this case, the problem must be rectified before proceeding further.

**THE TRUSSES MUST NOT BE MODIFIED ON SITE WITHOUT FIRST SEEKING ADVICE FROM A TRAINED SOFTWARE USER OR ENGINEER.**

### Correct direction of ENDUROTRUSS® chord profile

The direction of the channel section used for the chord should be as depicted on Truss Assembly diagrams in (see Figure 5.11.) Trusses should be oriented as shown on the truss layout drawing provided and ensure load bearing points shown on the assembly drawings align with load bearing walls.

### Material specification

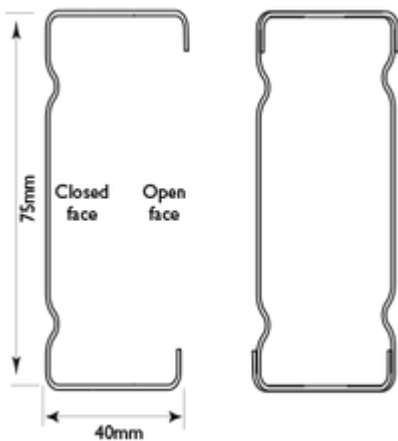
ENDUROTRUSS® sections are roll-formed from TRUECORE® steel complying with AS1397:2011. The standard ENDUROTRUSS® sections are shown in **Figure 4.1**. In the grade shown, the number prefixed with G indicates minimum yield stress in MPa; and the number prefixed with Z or AM indicates minimum coating mass in g/m<sup>2</sup>.

0.55mm BMT, TRUECORE® G550 AM150 steel

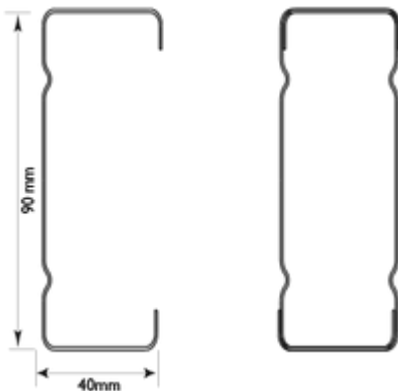
0.75mm BMT, TRUECORE® G550 AM150 steel

1.00mm BMT, TRUECORE® G550 AM150 steel

1.20mm BMT, TRUECORE® G500 AM150 steel



S75 section and boxed S75 section



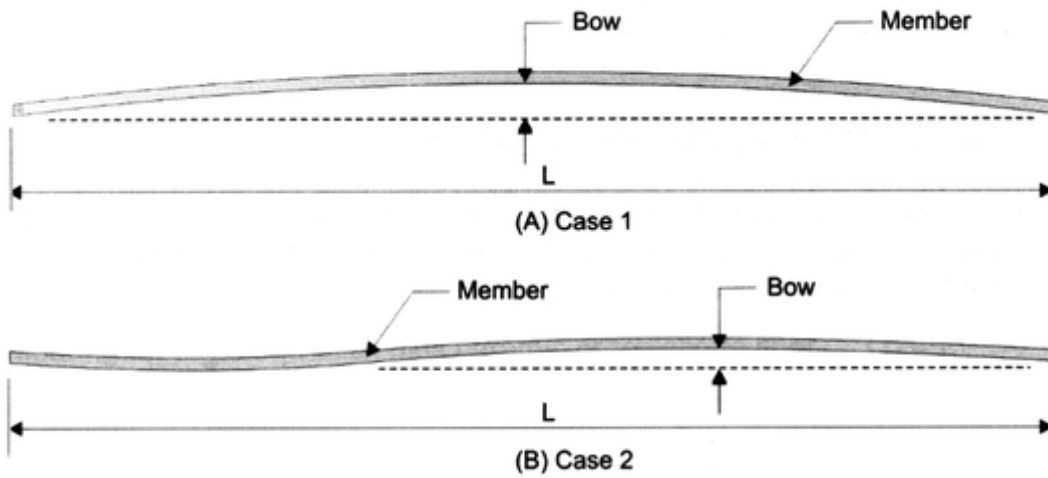
S90 section and boxed S90 section

**Figure 4.1 Section types**

### Straightness

Trusses and rafters must be installed with an overall out of plane straightness not greater than  $L/500$  where  $L$  is the length of the member as shown in **Figure 4.2**.

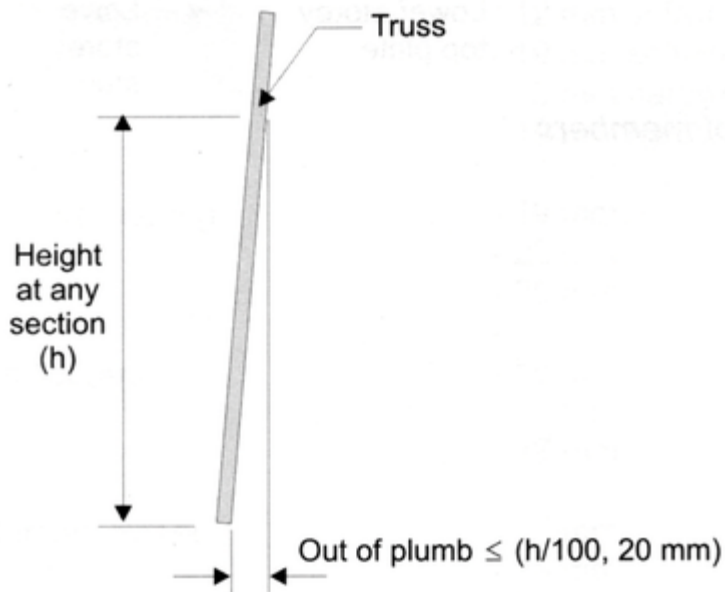
Differential in vertical bows between adjacent members must not exceed  $1/150$  of their spacing or 6mm whichever is less.



**Figure 4.2 Straightness**

### Plumb

Out of plumb at any point along the length of the truss from top to bottom, must not exceed the minimum of  $h/100$  or 20mm unless the trusses are specifically designed to be installed out of plumb. (See **Figure 4.3** below)



**Figure 4.3 Plumb**



## 5.0 Truss identification

A summary of the description of trusses is shown in **Figures 5.1** and **5.2**, and a glossary of terms is indicated below.

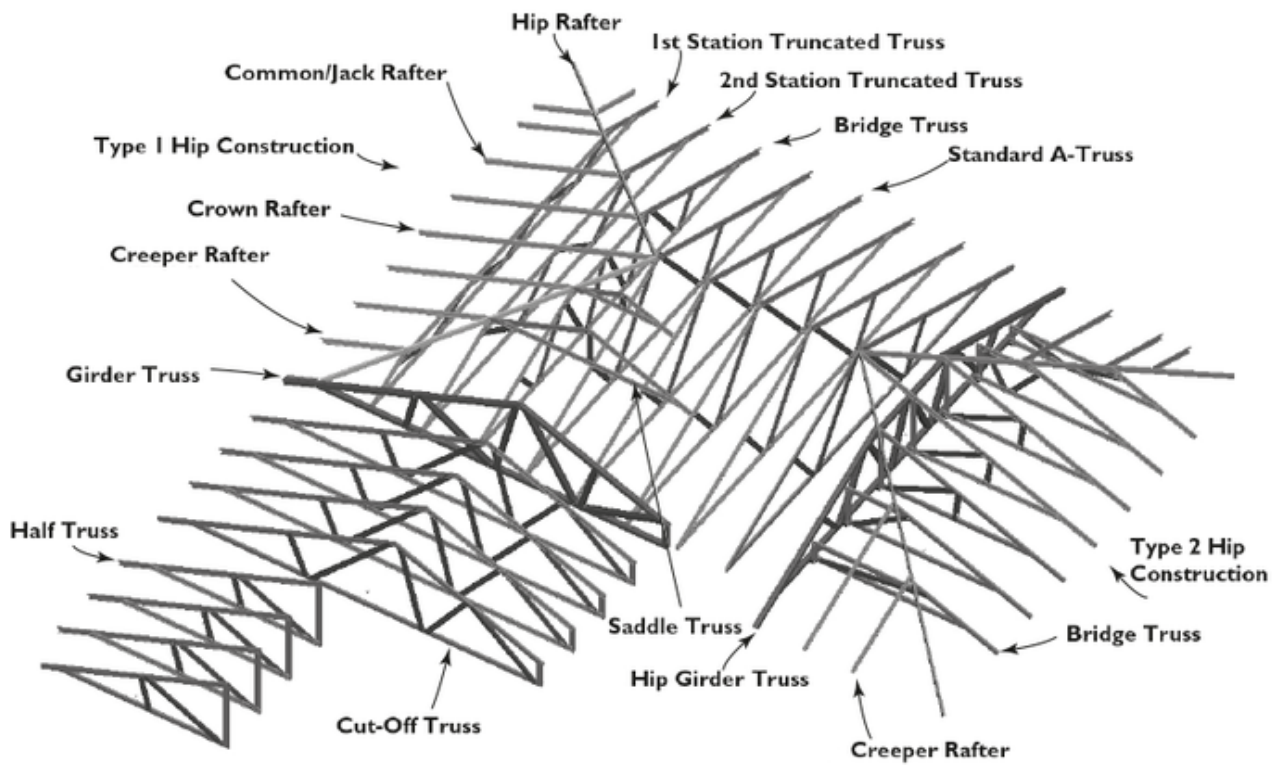


Figure 5.1 Typical Roof truss components

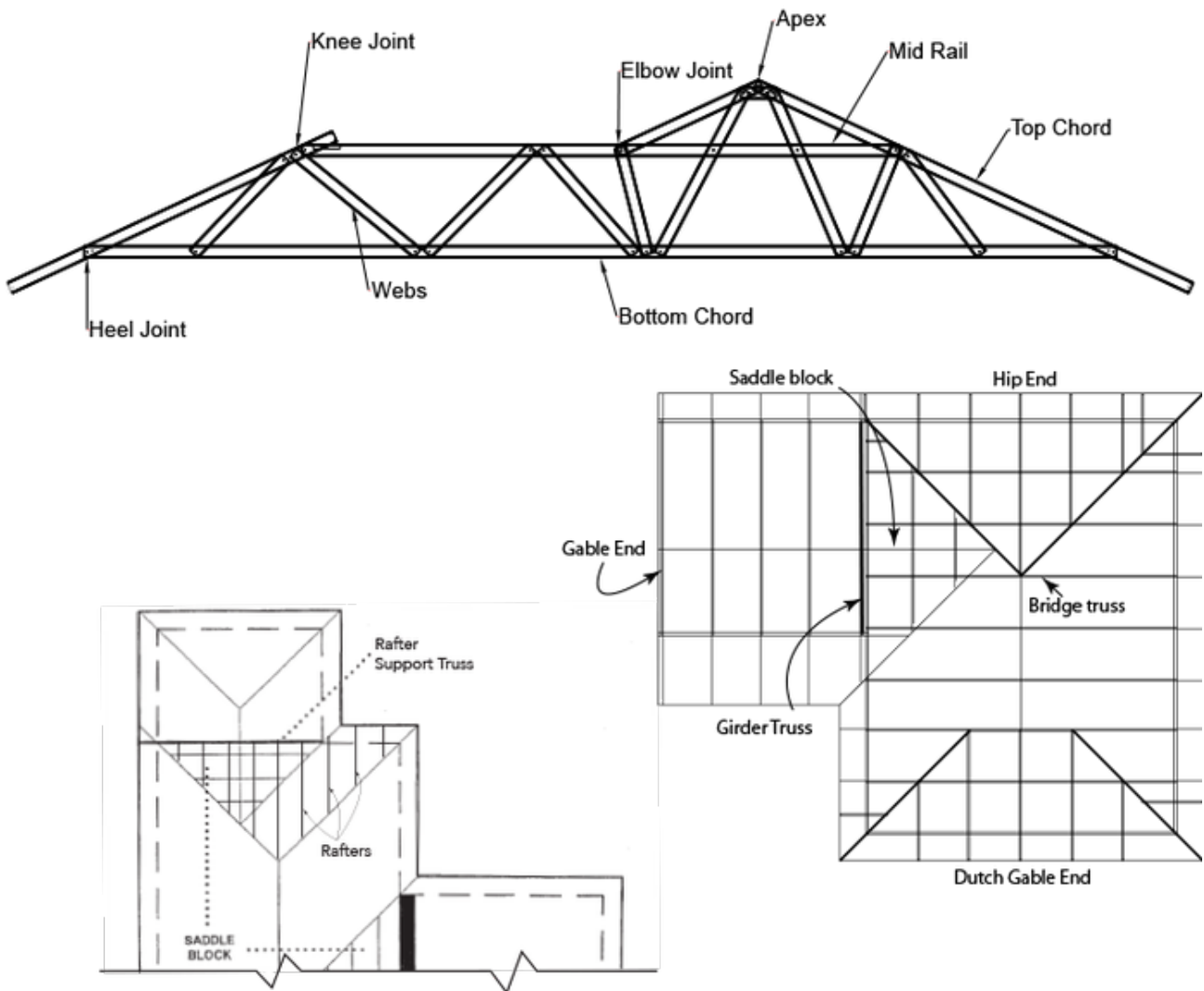


Figure 5.2 Roof truss components (plan view)

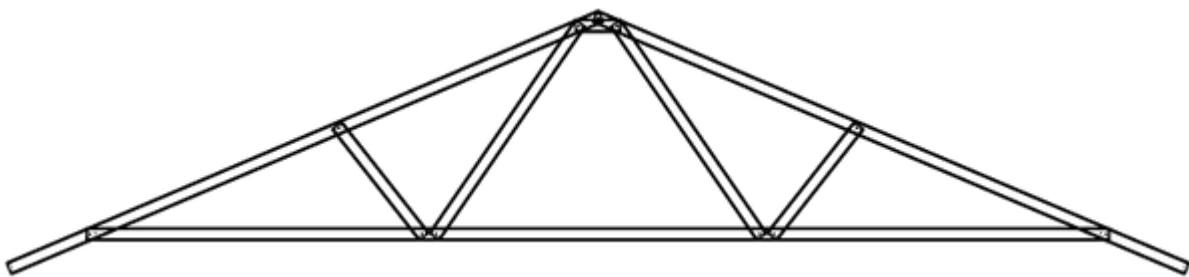
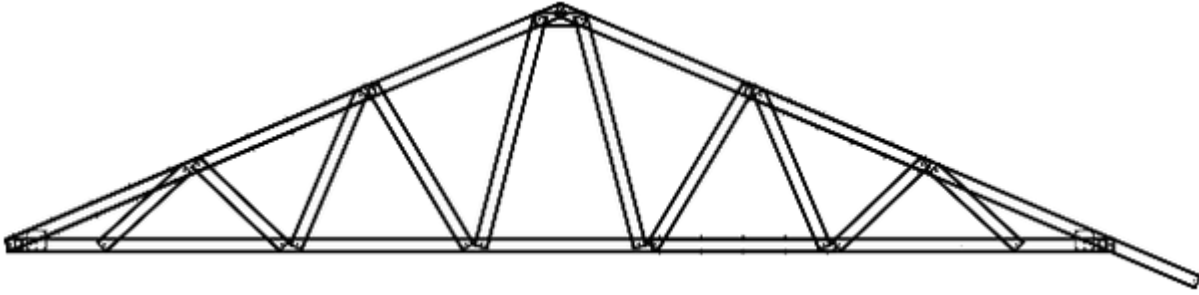


Figure 5.3 Standard 'A' Truss/ Dutch Gable Truss

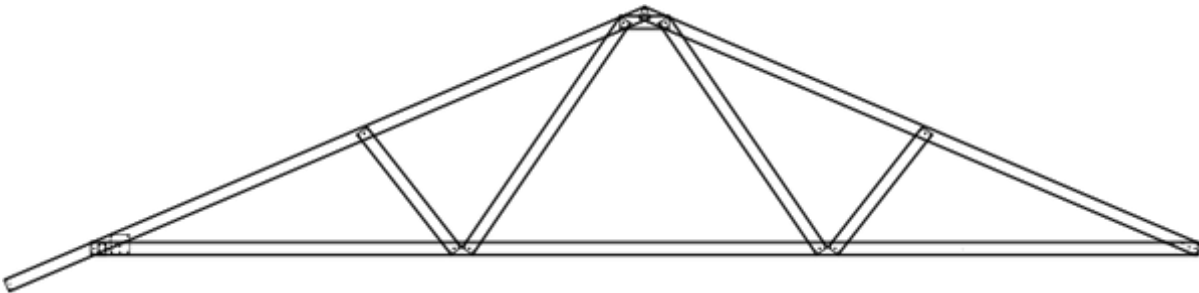
**Standard A-Truss:** An A-framed truss supported at both ends by load bearing walls. It forms the main gable roof block (Refer to Figure 5.3).

**Dutch Gable Truss:** A Dutch Gable truss is formed when whaling plates are fixed to the flat face of an A-truss to support common rafters.



**Figure 5.4 Girder Truss**

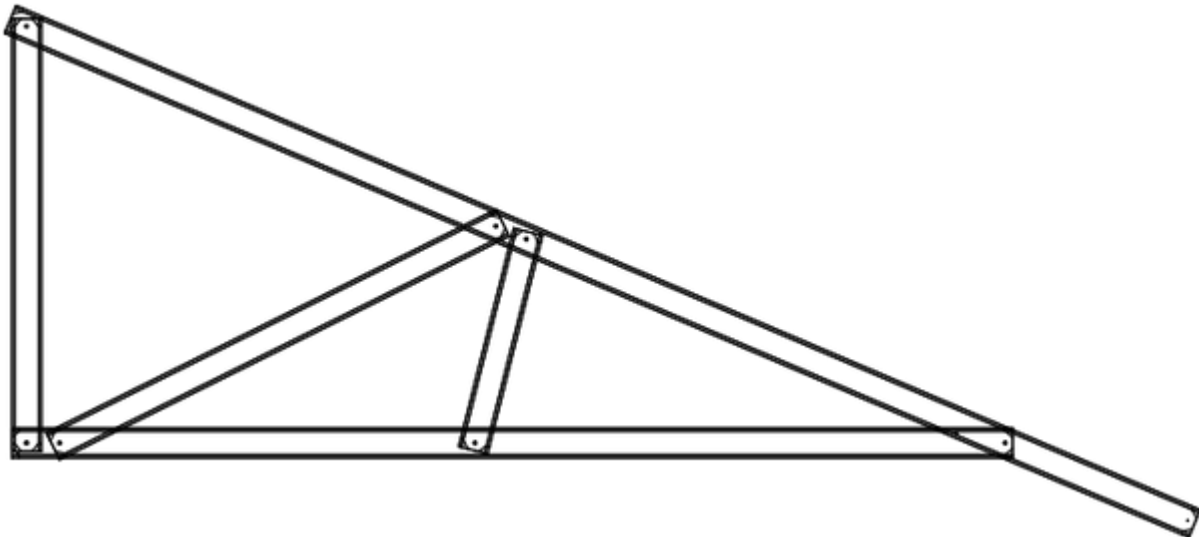
**Girder Truss:** A structural truss at the end of a roof block that supports incoming trusses from an adjoining block (bridge trusses). A girder truss may replace a supporting wall or beam. It can be used to support bridge trusses and may be used in lieu of an internal load bearing wall or beam (Refer to **Figure 5.4**). A girder truss may be either a single truss or a pair of trusses installed lip to lip.



**Figure 5.5 Bridge Truss**

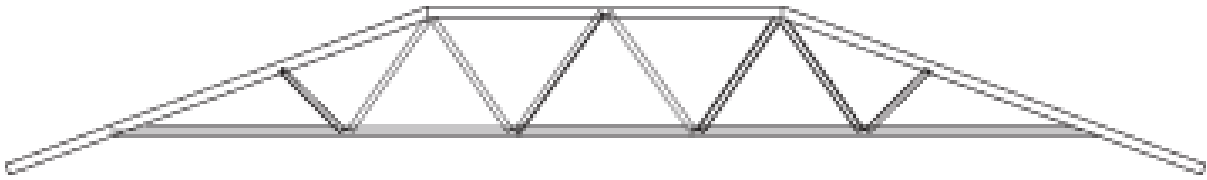
**Bridge Truss:** These trusses are standard trusses or truncated trusses with the overhang removed at the heel as shown below.

**Creepers Support Truss:** A truss which has an angle lintel fixed to the flat face of the bottom chord. It is used to support the ends of the creeper rafters when a roof incorporates an internal hip.



**Figure 5.6 Half Truss**

**Half Truss:** A triangular shaped truss with the end web fixed vertically and at 90 degrees to the bottom chord. It is commonly used to form verandah roofs on the lower floor of two storey homes (Refer to **Figure 5.6**).

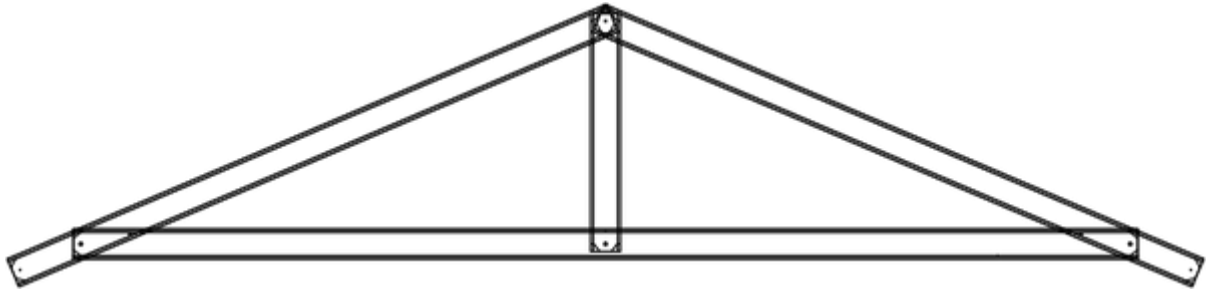


**Figure 5.7 Truncated Truss/Hip Girder Truss**

**Truncated Truss:** A truss of varying depth with a horizontal top chord. Truncated trusses are usually used to form a hip end (Refer to **Figure 5.7**).

**First Station Truncated Truss:** The first truncated truss in from hip end wall.

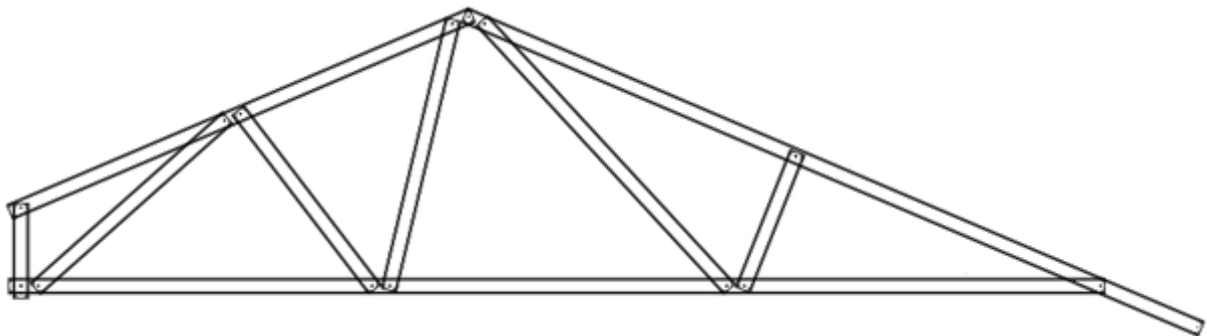
**Second Station Truncated Truss:** The second truncated truss from hip end wall.



**Figure 5.8 Saddle Truss**

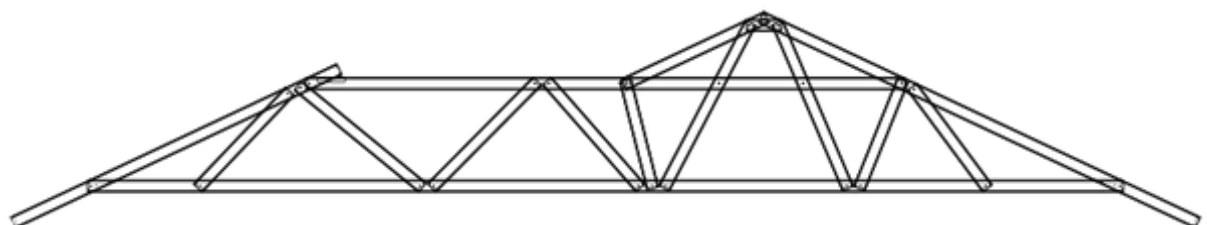
**Saddle Truss:** A truss with the top chords cut at the heel to form a foot cut. It is used to form a valley line when two roof planes intersect. Saddle trusses are supported by trusses or rafters below (Refer to **Figure 5.8**).

**Truncated Saddle Truss:** A saddle truss with a horizontal top chord used to form a valley line when two roof planes intersect with a hip end close to the valley. It supports hip end rafters.



**Figure 5.9 Cut-off truss**

**Cut off truss:** A standard truss with a cut to one or both ends.



**Figure 5.10 Peak truss**

**Peak truss:** A truss that helps to create four or more roof faces. The Peak truss may support one or more hip and valley lines.

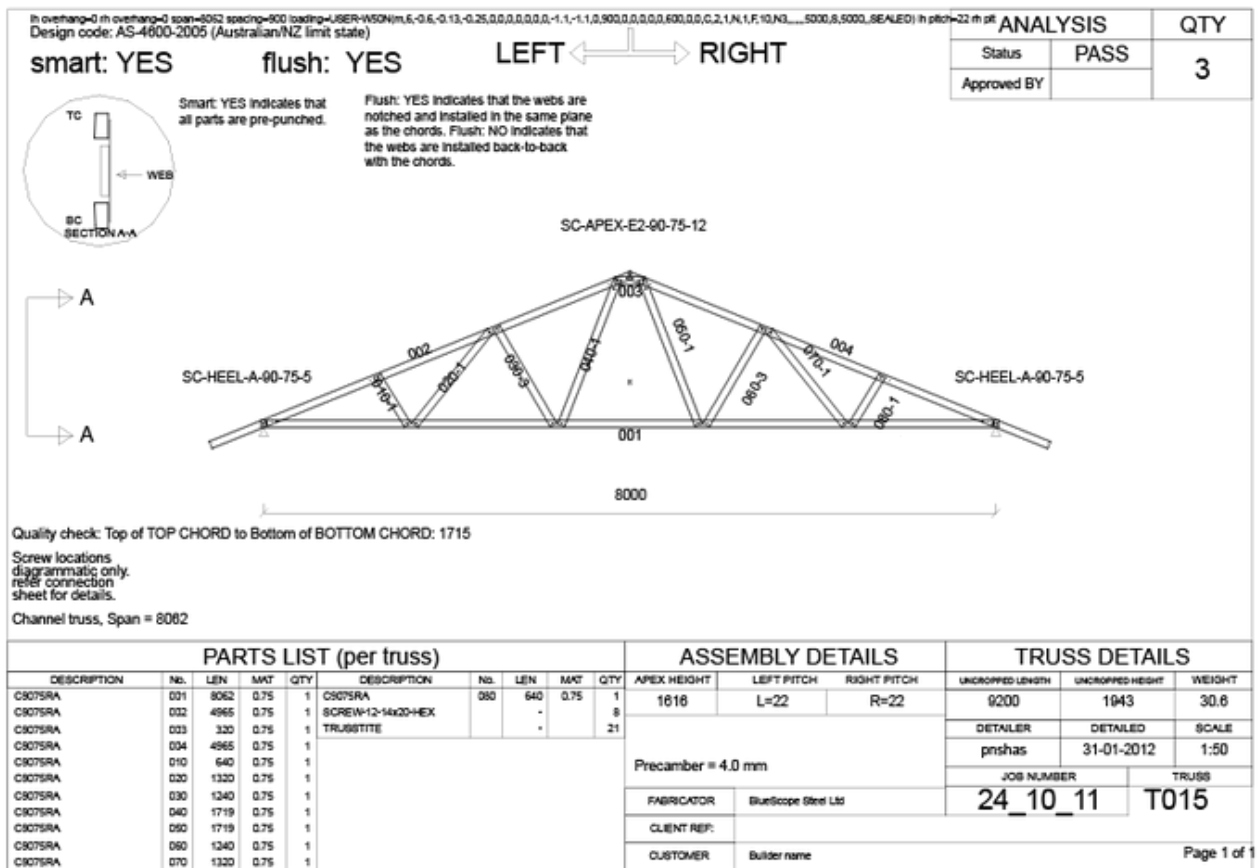


Figure 5.14: A typical truss assembly sheet as produced by ENDUROCAD® SOFTWARE.



## 6.0 Truss Assembly

### 6.1 ENDUROTRUSS® Framing System marking and branding

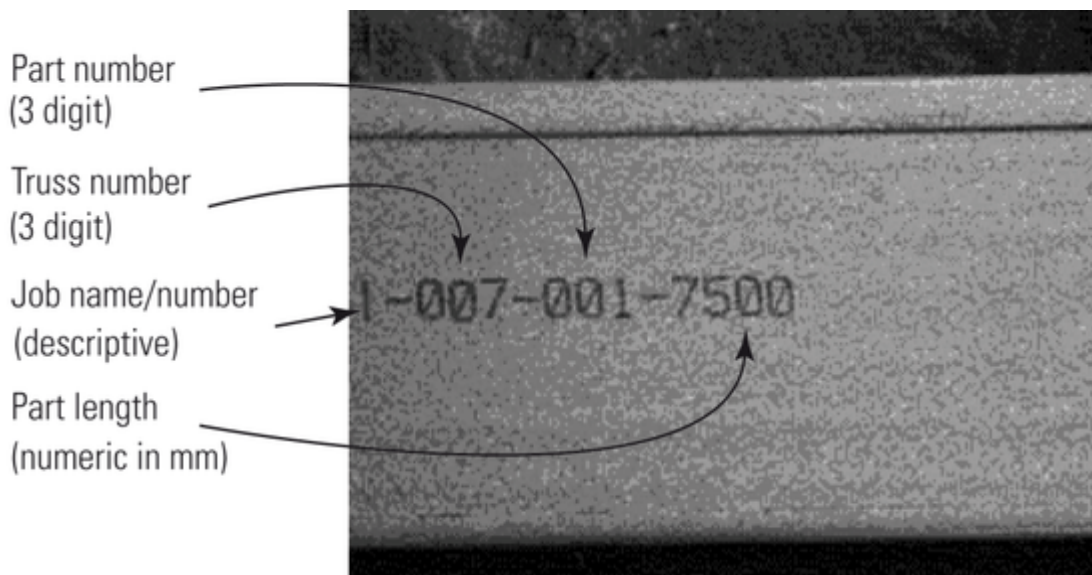
All ENDUROTRUSS® Framing System parts are coded with information to assist erectors in the assembly process. This matches the part information shown on the assembly drawings.

All ENDUROTRUSS® Framing System parts are coded with the following on both the web and the flange of each section:

- Job Name/Number
- Truss Number
- Part Number
- Part Length
- Part Usage.

They also contain the rollformer number and date of manufacturing for traceability purposes. Inkjet marks are truncated on shorter parts so some information may not be visible on shorter parts.

With this information, erectors can identify what the part is and where it is intended to be used in the structure. The illustration below shows how the coding works. The sections are marked when produced in accordance with **Section 6.1** of this manual.

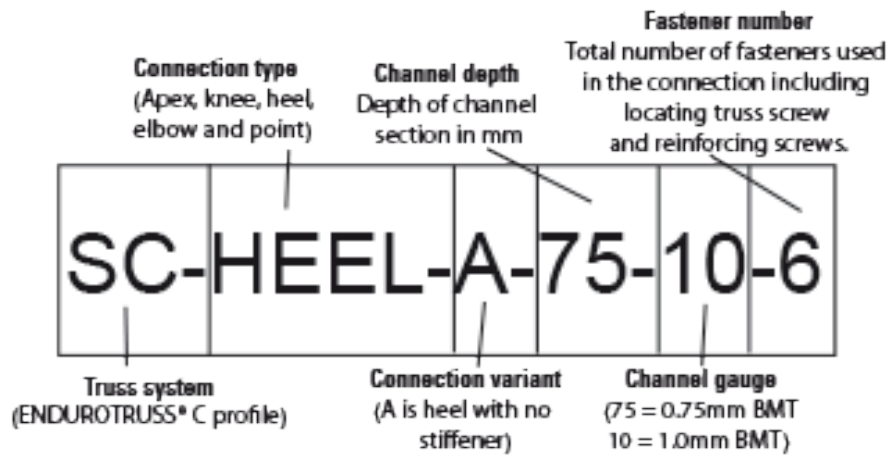


**Figure 6.1 Marking and branding**

So the above example illustrates that this member is for Job Number 1, it is part of truss number 7 (as numbered by the software in the construction drawings), it is part number 1 and is 7500mm in length.

## 6.2 Chord to chord connection identification

Connections are identified on the truss assembly sheet by a connection code. The connection detail is displayed on an ENDUROCAD® software generated connection sheet showing all the connections used in the specific job. The chord to chord connection code is displayed next to the connection on the assembly sheet. (Refer to **Figure 6.2.**)



**Figure 6.2** Connection identification

The connection code is explained using the above example

Example SC-HEEL-A-75A-75-10-6

Field 1 The truss system- in this case ENDUROTRUSS® C profile

Field 2 The connection type - Options:  
APEX, KNEE, HEEL, ELBOW and CHORD POINT

Field 3 The Connection- Type A is a heel for a tiled and sheet roof

Field 4 The depth of the channel section

Field 5 The gauge of the channel - 10 is 1.0 BMT and 75 is 0.75 BMT

Field 6 The number of fasteners used in the connection. Includes any locating truss screw, reinforcing screws or stiffener connection fasteners.

### 6.3 Fasteners

Truss members are joined together with two types of fasteners.

A locating Trusstite truss screw which is a hex-head fasteners with a trilobular thread for fixing through pre-punched holes and a #12-14x20 hex-head self drilling reinforcing fasteners. Fasteners should always be supplied by the manufacturer of the trusses and be in accordance with the specifications described in the ENDUROFRAME® Design Manual for mechanical and coating properties. All fasteners should have a minimum Class 3 coating. The specifications of the locating Trusstite truss screw may be either:

- #17-15x15 hex. head or
- 5/16"-12x17 hex. head screw.

The use of the correct fasteners in the quantities shown in the truss fabrication drawings are essential to ensure the design capacity of the trusses are achieved.

The following illustrations show the typical steps for assembly of a truss. In this example the webs are linked for ease of locating the parts.

### 6.4 ENDUROTRUSS® Framing System assembly

The following illustrations show the typical steps for assembly of a truss.



#### Step 1: Part Identification

Unpack the trusses and sort into truss lots using the branding as a guide. Identify the chords and webs from the branding information on the parts.



#### Step 2: Truss Layout & Chord Assembly

Identify the chords and lay toes down on a level surface or assembly table and align as per assembly drawing. The chords should be pre-notched allowing parts to overlap as shown. Pre-punched holes are provided for locating truss screw to connect the chords at the apex, heel and knee.

**Note:** branding is on the side flange which will be on the inside of the truss chords which can aid in laying out.

#### Step 3: Align holes and install a locating truss screw - fix at heels

When carrying out the primary assembly of the heel align notch holes as shown and install a locating truss screw in holes.





**Step 4: Fix at apex or knee and install a locating truss screw**

Align notch holes as shown and install a locating truss screw in holes.



**Step 5: Web Installation**

Separate linked webs by cutting or snapping pieces apart. If webs are joined they will be attached in the order required for assembly (Left to right). Snip or snap the webs apart and position each one over the truss chords near their final location. Where flush truss is being used (as in this example), the branding on the webs will face towards the top of the truss and toes of the channel will face down. For a non-flush or back to back truss the flanges of the webs face up and no notches are provided at the web ends.





**Step 6: Align holes and fix connection with a locating truss screw**

Using part identifier numbers layout the webs in accordance with the Assembly Sheet. Line up the 6mm locating holes on the ends of the webs with the appropriate holes on the truss chords. If a "flush" truss is being installed the flanges of the web are to face downwards in line with the truss chords. Install a locating truss screw into the aligned holes ensuring that the screw is driven firmly home and does not strip. Should the locating truss screw strip, reduce the driver torque and place a 12-24x20 self drilling screw 20mm minimum from the locating truss screw.



**Finished knee web connection (unreinforced)**





**Finished connection (reinforced)**



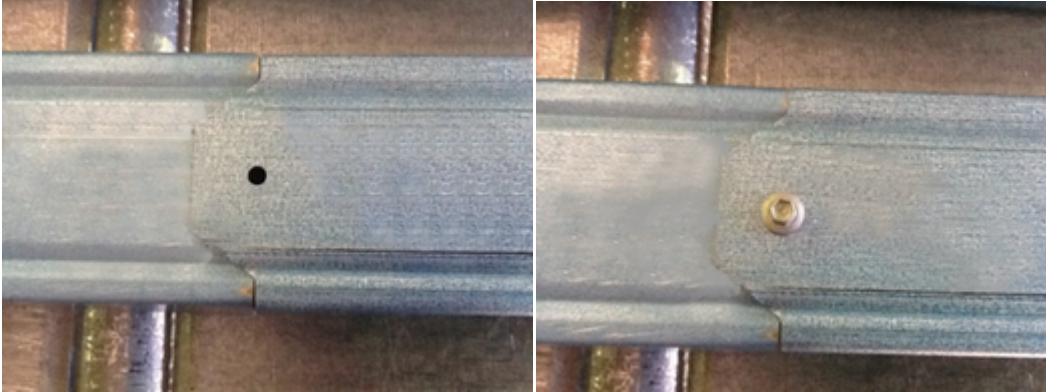
**Step 7: Overall Quality Check** Before inserting any stiffeners or reinforcing screws check the overall dimensions of the truss against the Assembly Sheet.

For a complex shape truss, lay it on top of a previously assembled one and check they are the same.

## 6.5 ENDUROTRUSS® splicing

Large span trusses may be too large to economically transport and components may be too long to rollform and handle through the manufacturing workshop. The detailing software allows the Trained Software User to set a maximum component length. Where this length is exceeded the software will create a splice to subdivide the component. The splice will be located between truss panel points and close to the centre of the panel.

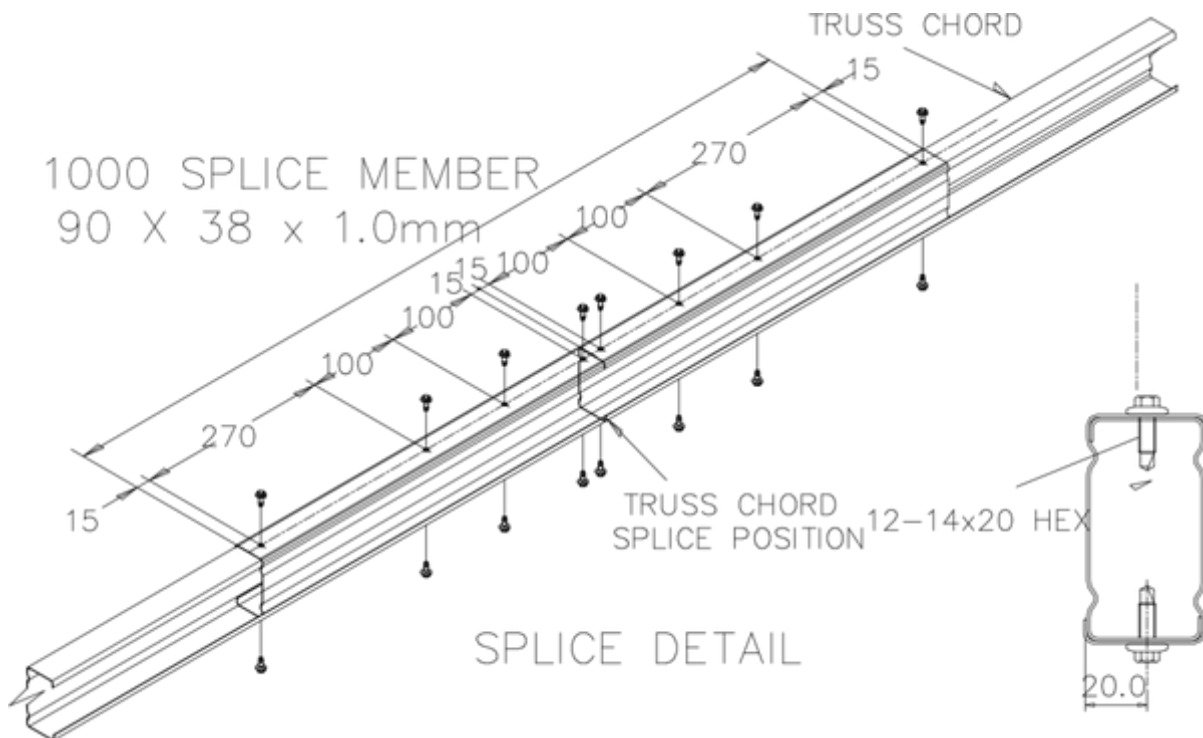
The two bottom chord members connect using the standard notched end as shown in **Figure 6.3**.



**Figure 6.3** Bottom Chord connection at splice

After the chords are connected, a boxing piece is placed over the chords and fixed with 12-14x20 self drilling screws following the connection details in **Figure 6.4**.

Boxing member is Ribbed Channel of the same gauge and depth as the truss.



**Figure 6.4.** ENDUROTRUSS® Splice Details

### 6.5.1 Splicing of Boxed Chords

Splicing of boxed chords is to be in accordance with the following diagram.

**Note**

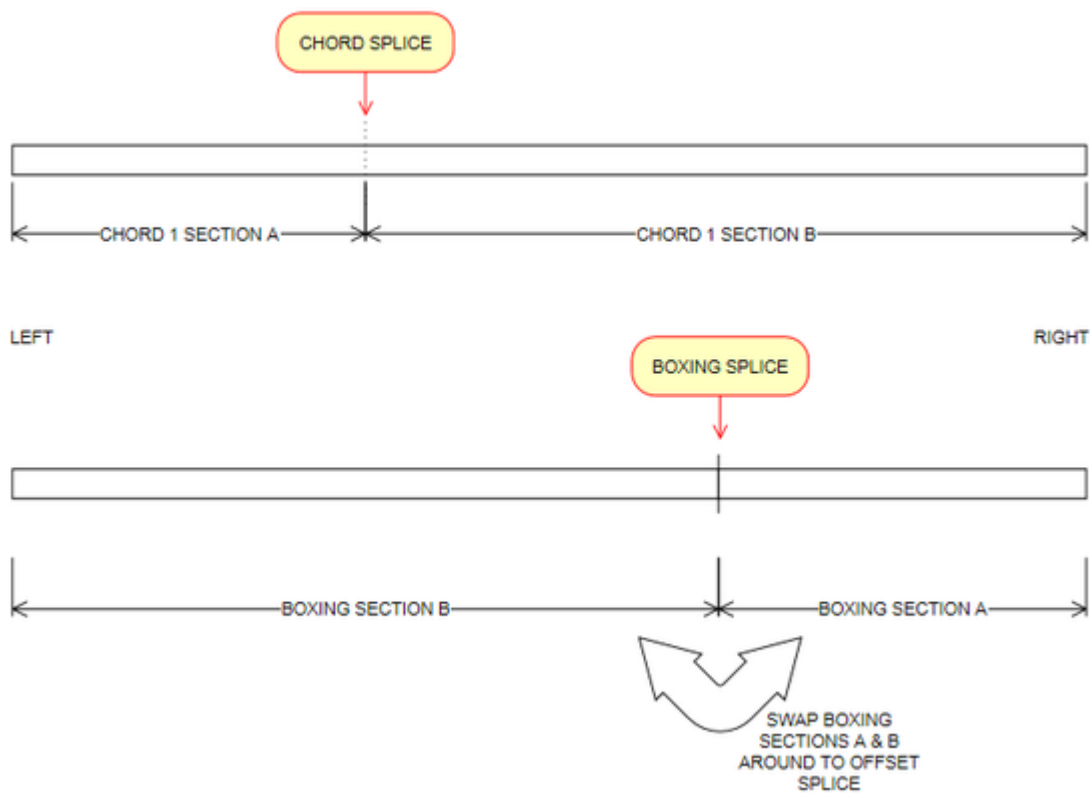
**Note:** The splice points for the individual members must be separated by a minimum of 600mm

A piece of U section stiffener the same gauge as the chords is to be housed over the spliced sections and extend 250mm either side and fixed with the recommended number of M6-1P x 18mm smooth top Tek screws.

Where the splice is separated by more than 1500mm it is more practical to apply a 500mm length of U section stiffener to each join and fixed with 6 x M6-1P x 18mm smooth top Tek screws to each end.

### 6.5.2 Splicing Boxed Chords

To maintain a minimum 600mm separation on the individual splice locations, the splice is to be placed at a minimum of 300mm from the centre of the required cut point. The chord boxing sections are then to be installed reversed end-on-end to offset the splice location.



## 6.6 ENDUROTRUSS® Framing System stiffening and re-inforcement

Refer to the ENDUROCAD® software generated connection drawing and the assembly drawings to identify reinforcing screws and stiffeners required to complete truss assembly. Primary fixing screws are self-locating Trusstite screws fastened through pre-punched holes, while reinforcing screws are #12-14x20 hex-head self-drilling fasteners, without washers. Stiffening screws should be installed a minimum of 21mm from each other and the locating screw and a minimum distance of 10mm from the edge and 17mm from the end.

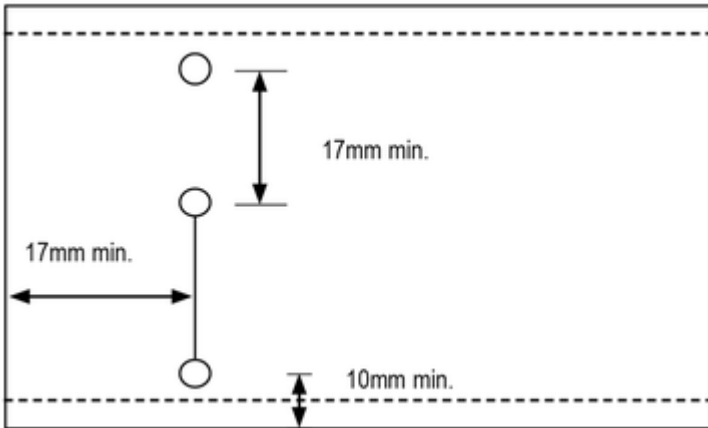
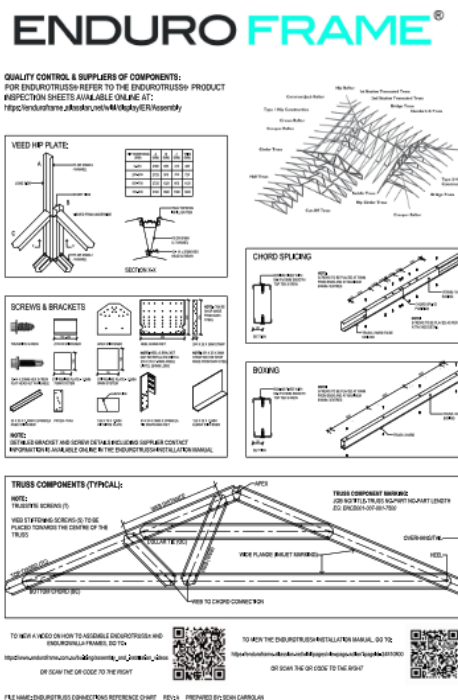
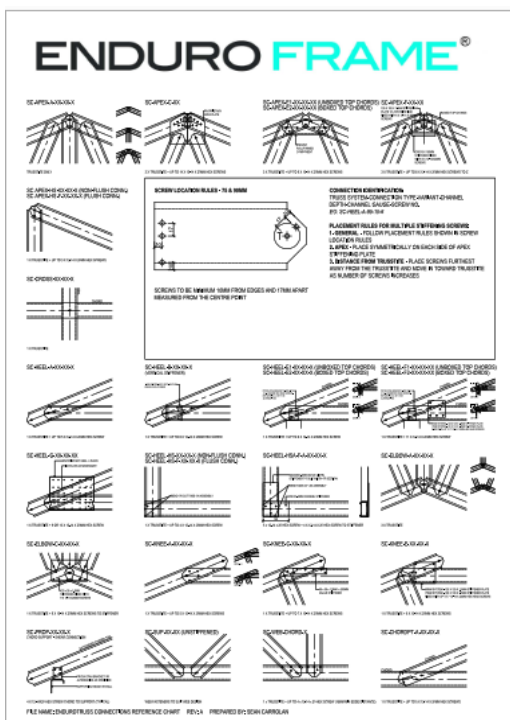


Figure 6.5 Stiffening screw distances

From the appropriate connection drawing, identify the location and type of stiffener and/or the screws required. Install as shown on the drawing. Different stiffeners are specified for various loading and geometry.

The following posters can be used to summarise the location of screws in connections. They can be printed in A0 and laminated and placed next to locations where trusses are to be assembled.



Available from the Enduroframe website.

### 6.6.1 Web stiffening

Identify webs requiring reinforcing screws by referring to the code printed on the part or the truss assembly drawing. For example 030-3 refers to three fasteners required on each end of web 030 - this is one locating truss screw and three #12-14x20 hex head screws. For larger trusses and flush, an additional screw may be placed in unreinforced webs to strengthen the trusses in the horizontal plane during handling, although they are not required for structural purposes. The position of the additional screw is as shown in step 6 of **Section 6.3**.

Placing additional screws in truss webs close to the inside flange of the truss chord helps to stiffen the truss when it is handled on its side, and can make installation easier.

### 6.6.2 Apex stiffening

Identify the number and location of reinforcing screws required for chord to apex plate connection by referring to the connection drawing for the apex type. The range of apex stiffening options are shown in **Table 3**.

For example SC-APEX-E1-75-10-5 means to install one locating truss screw and four number #12-14x20 hex head screws.

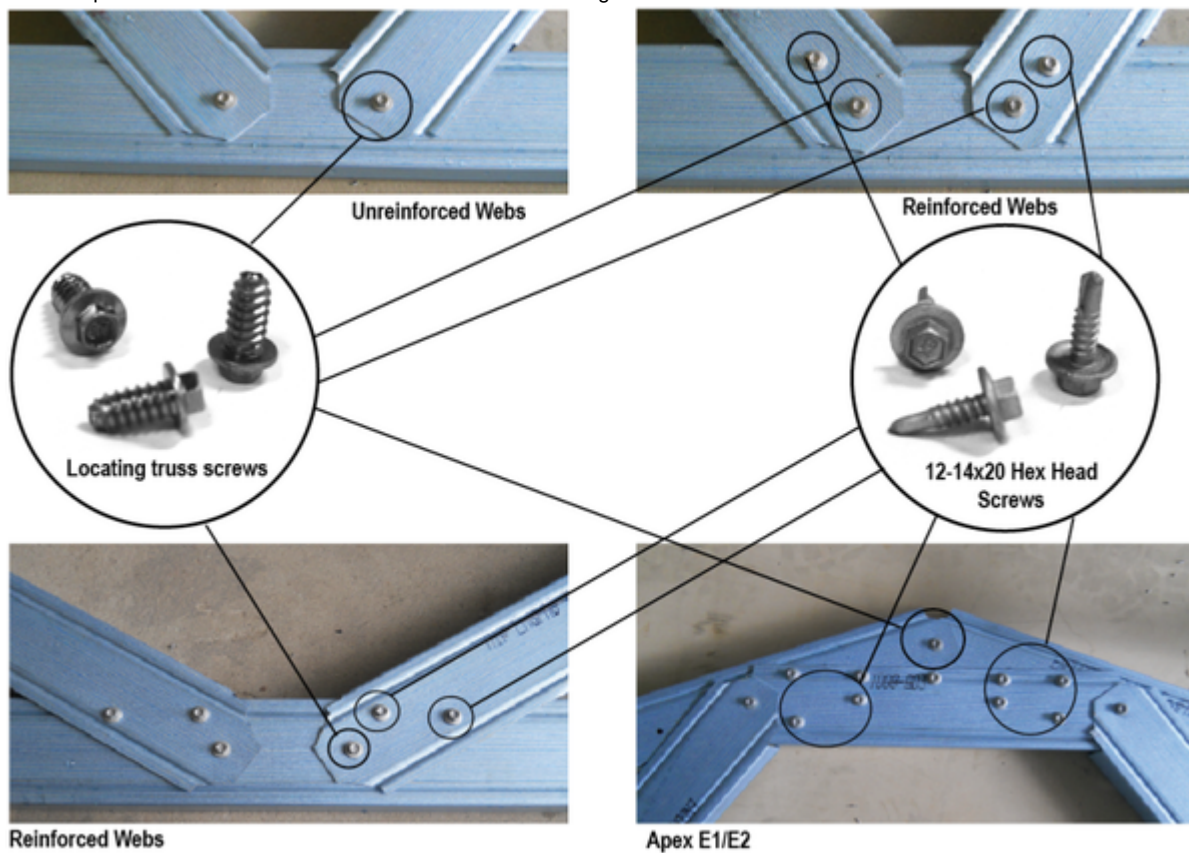
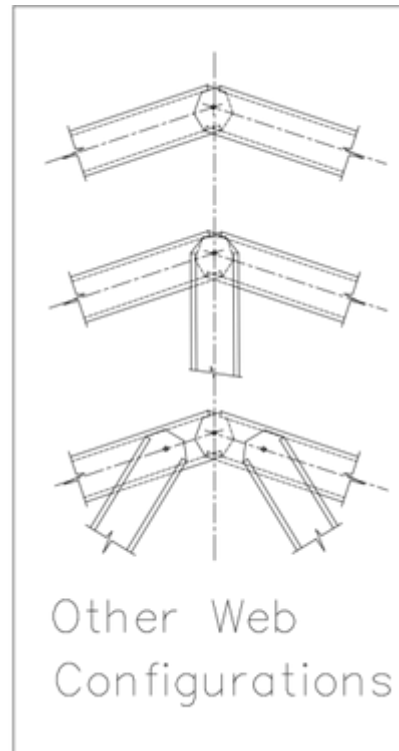
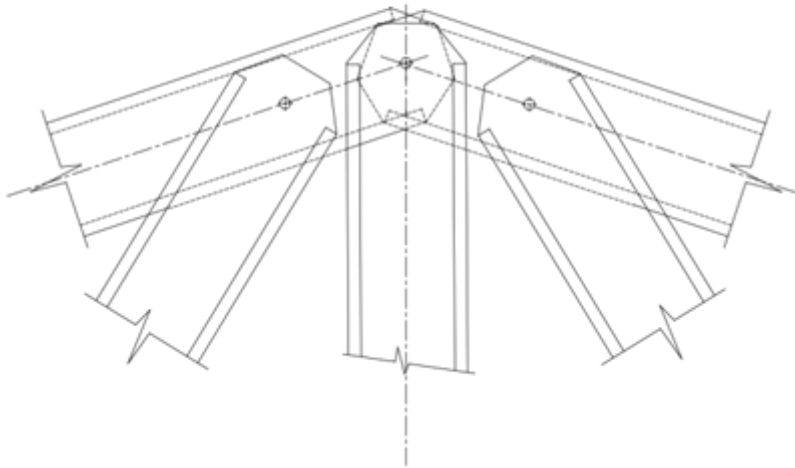


Table 3 Apex types

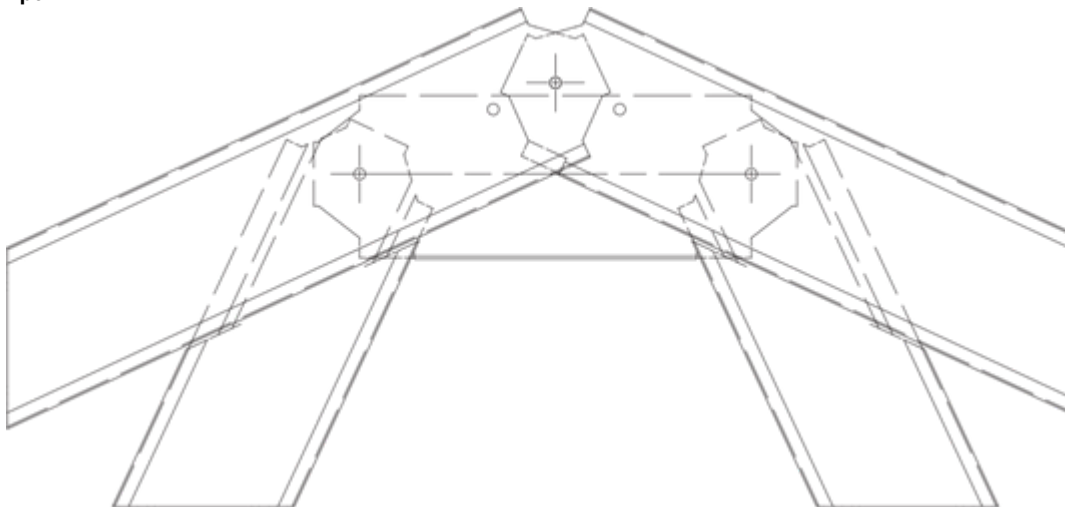


**Apex A**



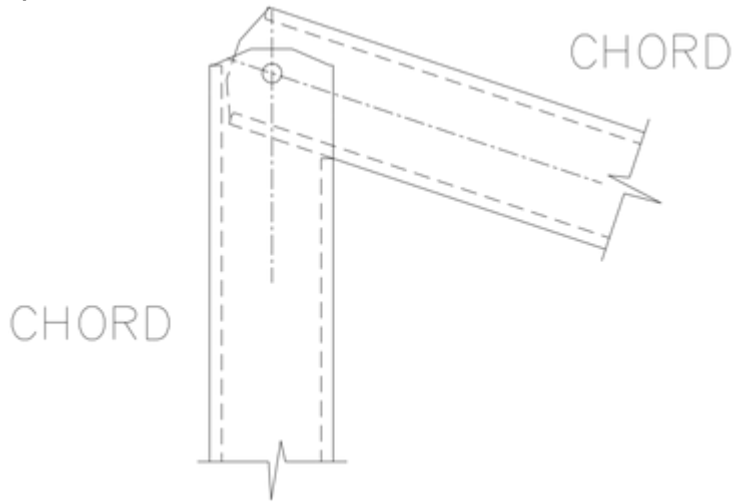
**No stiffeners or plates and a single Trusstite connection**

**Apex E1**



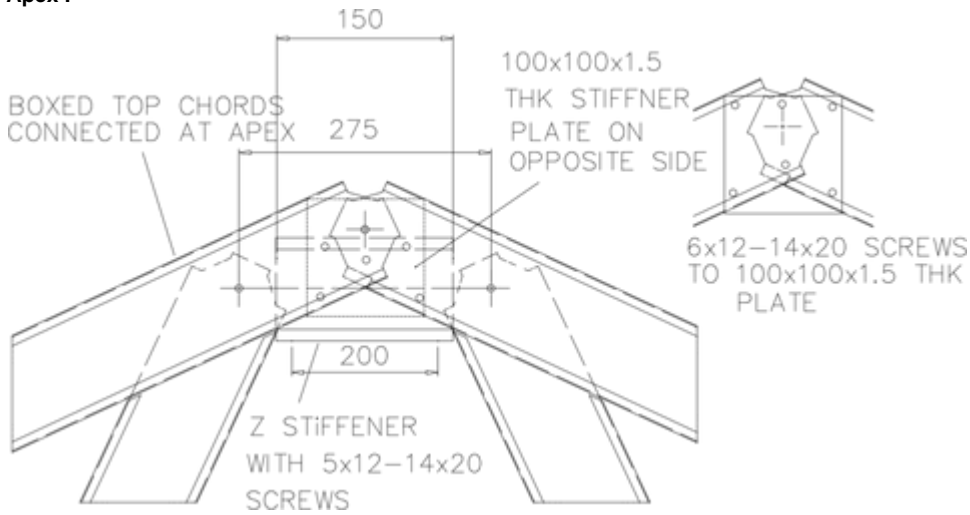
**Notched C stiffener plate across apex with webs connected to top chord**

**Apex HS**



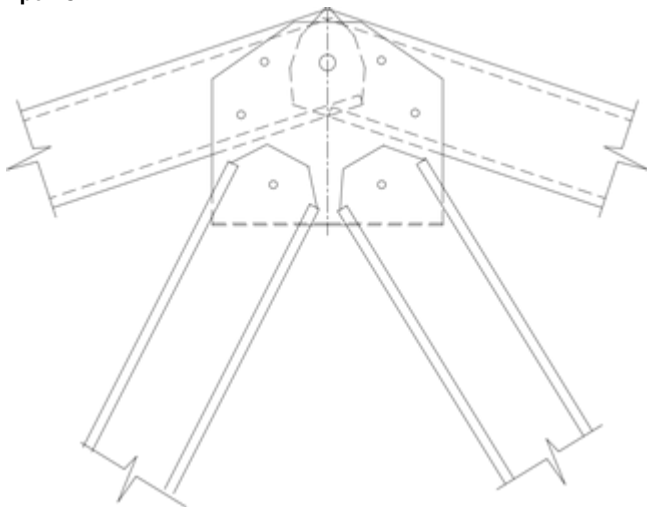
**Back-to-back chord sections**

**Apex F**



200mm long Z10015 section over 125 x 125mm x 1.5mm stiffener for 90mm section or 100mm x 100mm x 1.5mm stiffener for 75mm section

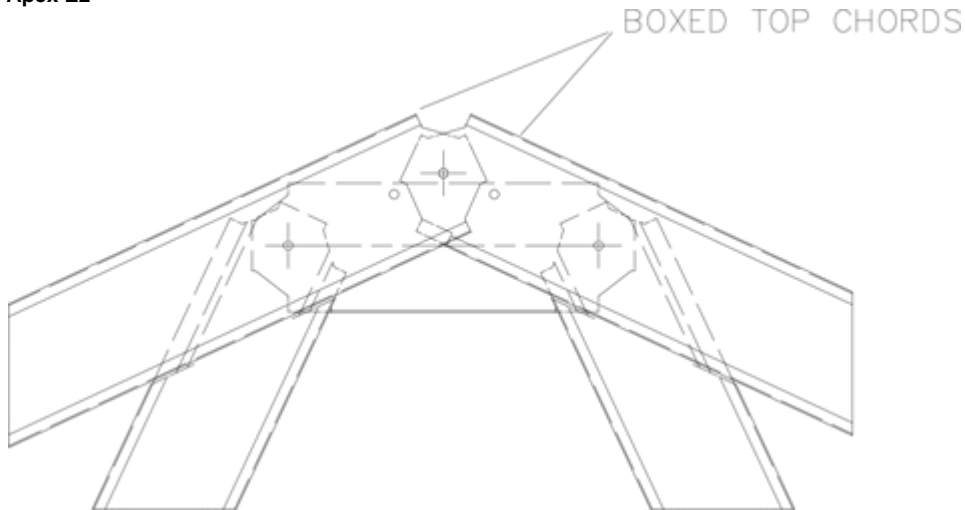
**Apex C**



**Standard apex plate connection**

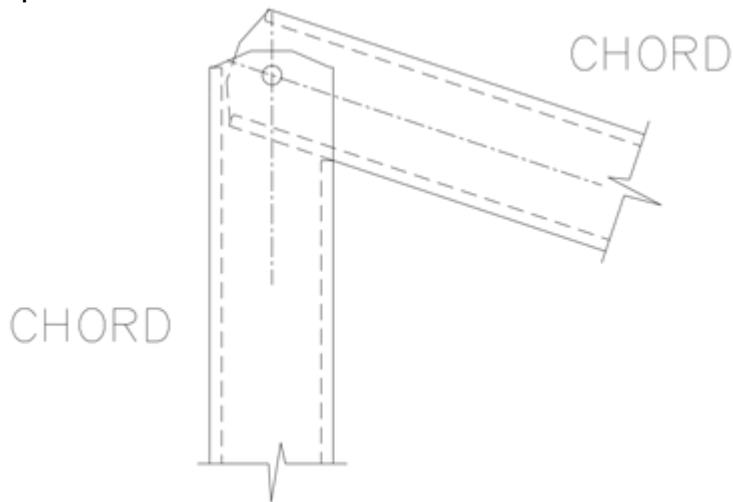
The fabrication drawing for the Apex C connection plate is located at this link - [Smart Truss Apex Plate P11350-2.pdf](#).

**Apex E2**



**Notched C section with boxed top chords**

**Apex HSF**

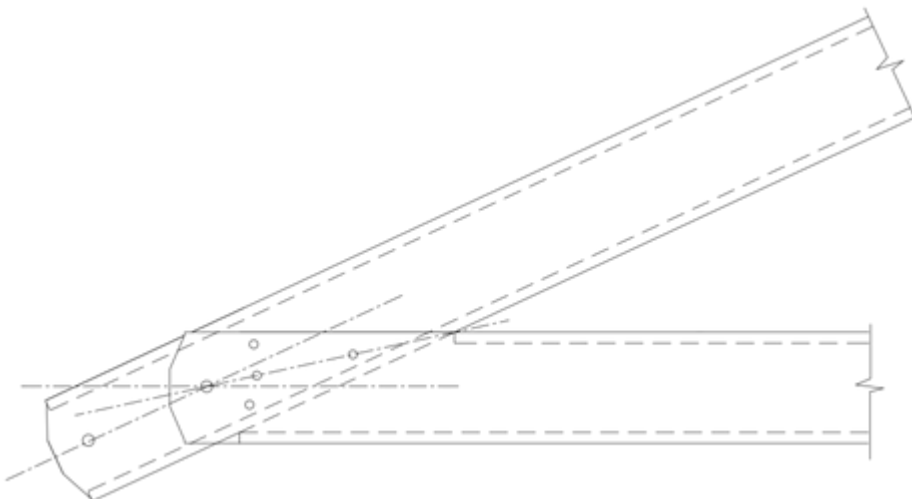


**Flush chord connection**

**6.6.3 Heel Stiffening**

A range of heel stiffeners are available to enhance truss capacities and are changed depending on whether a truss or sheet roof is being used. From the appropriate connection drawing, identify the location and type of stiffener and/or the screws required. Install as shown on the drawing.

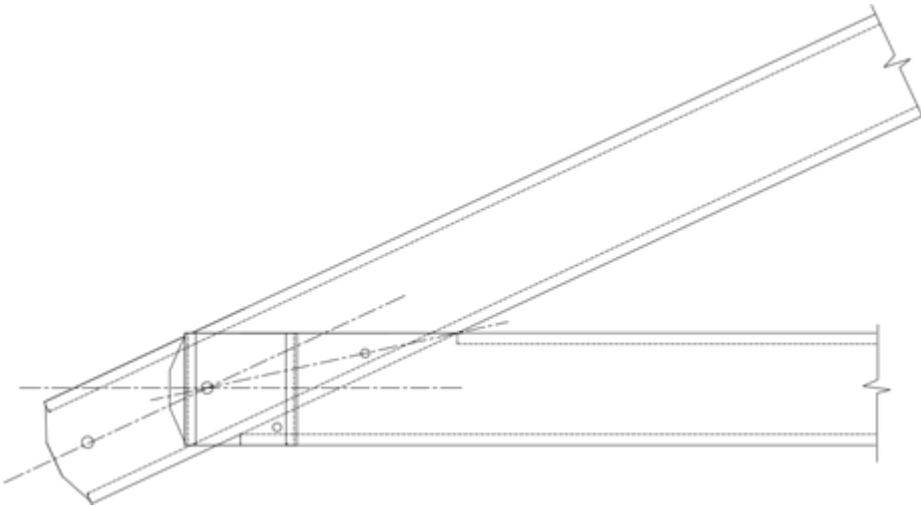
**Heel A**





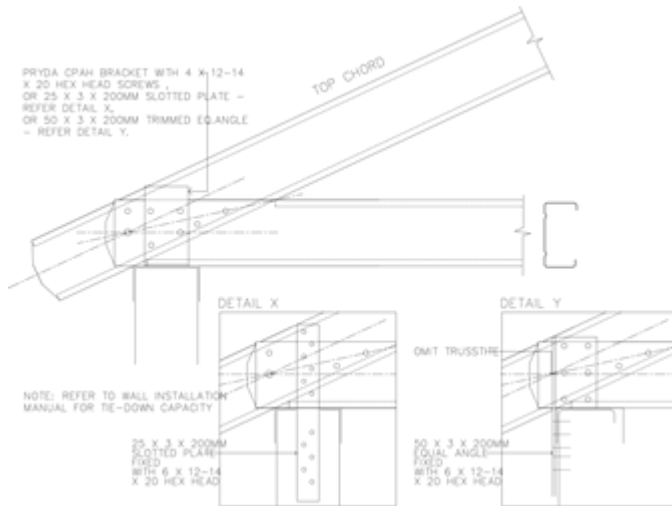
Heel Connection with no stiffener or brackets. Used for lower span tile roof and low wind areas sheet roof

Heel B



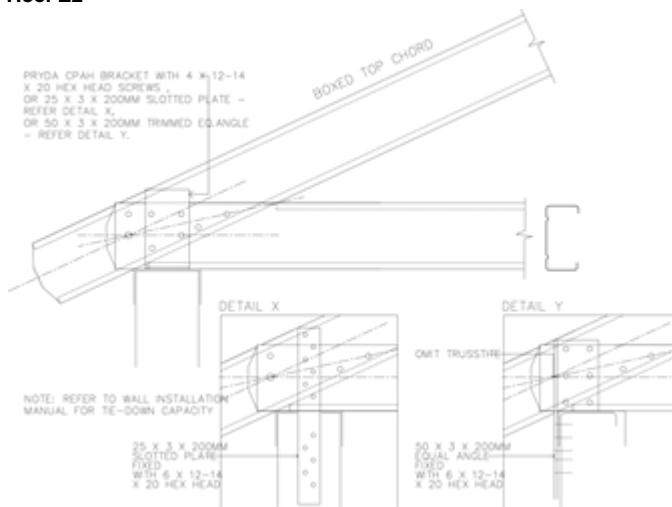
Heel Connection with vertical channel stiffener. Stiffener increases bearing capacity of connection

Heel E1



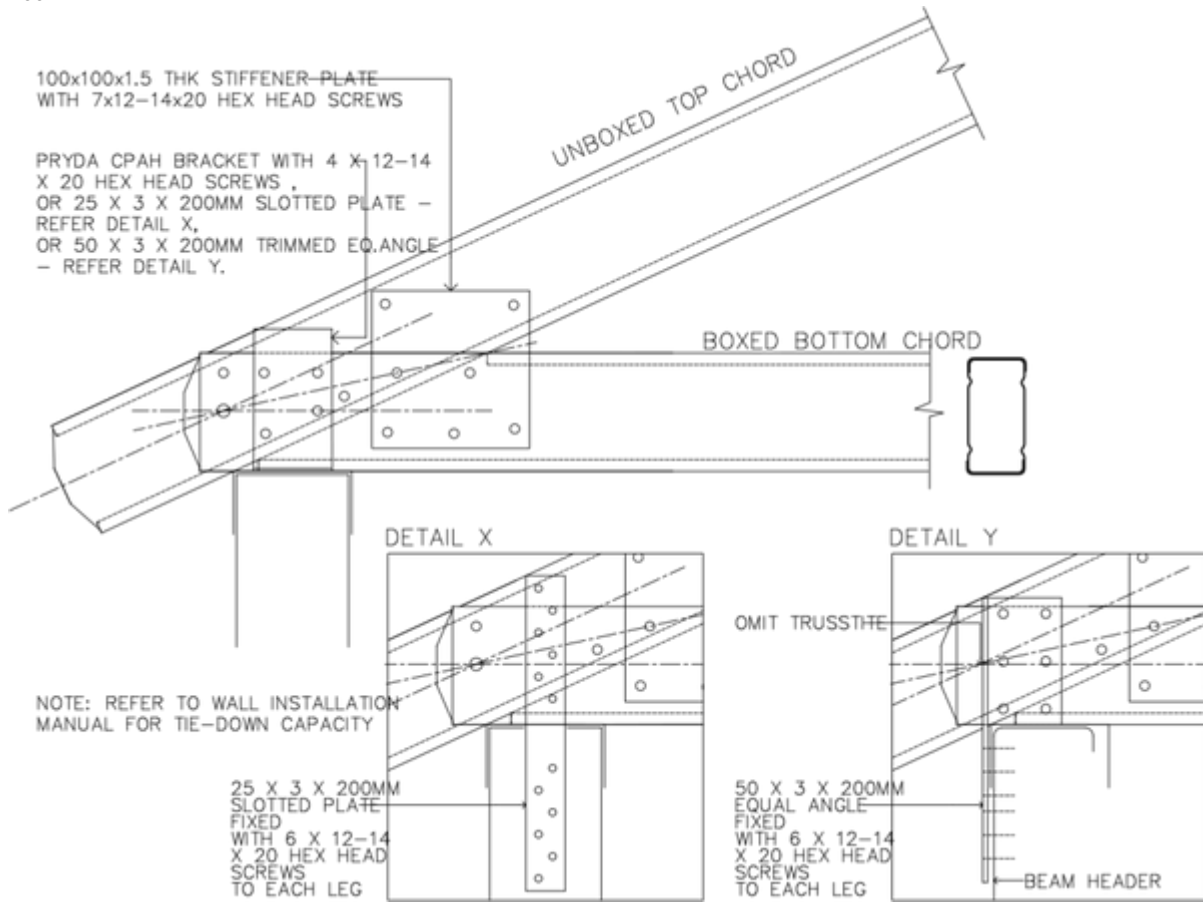
Heel strengthened with CPAH bracket, 25 x 3 x 200mm plate tie or 50 x 50 x 3 x 200mm equal angle tie

Heel E2



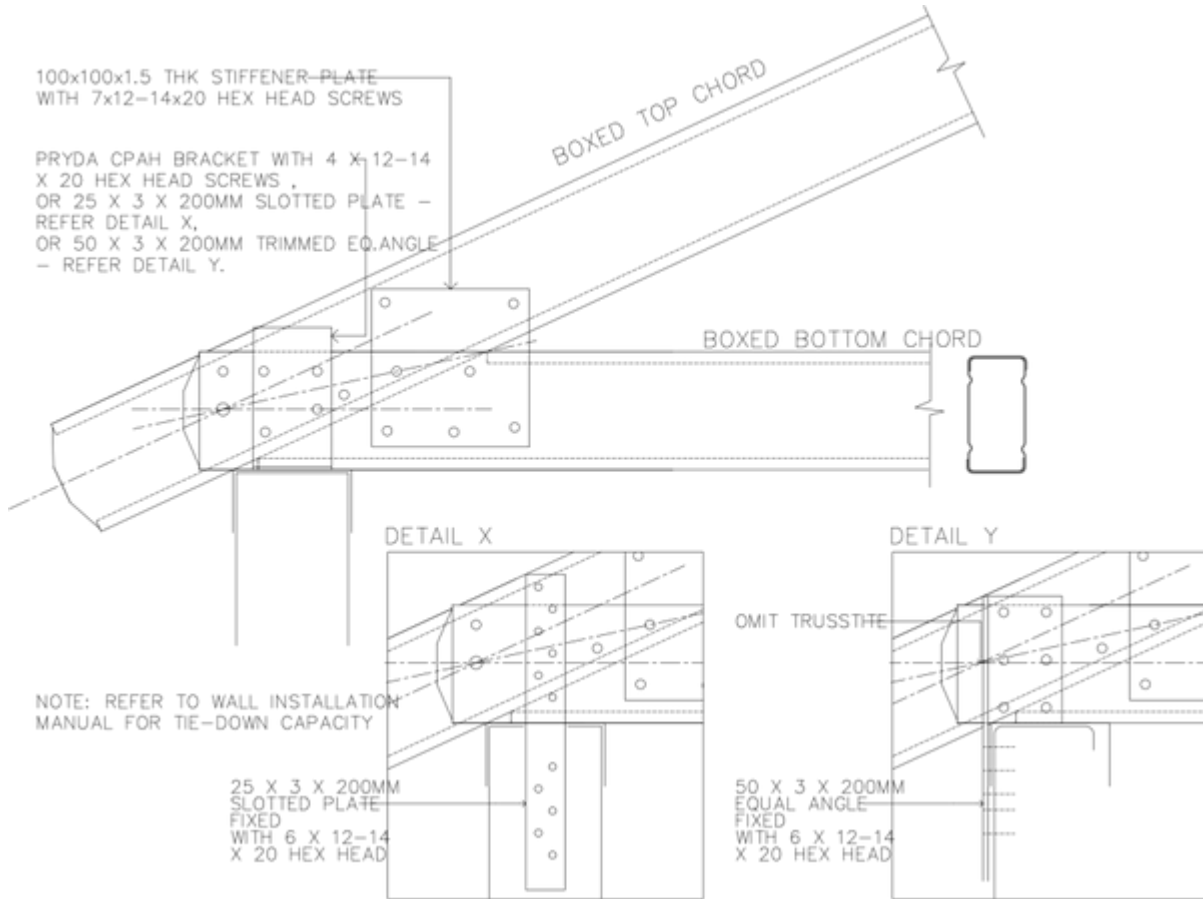
Heel strengthened with CPAH bracket, 25 x 3 x 200mm plate tie or 50 x 50 x 3 x 200mm equal angle tie, with a boxed top chord.

**Heel F1**



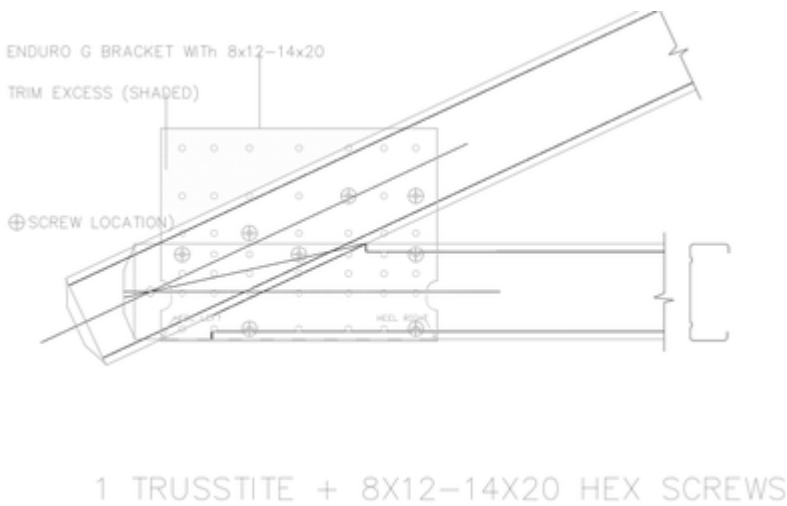
Heel strengthened with CPAH bracket, 25 x 3 x 200mm plate tie or 50 x 50 x 3 x 200mm equal angle tie and 100x100 x1.5mm plate for 75mm truss and 125x125x1.5mm for 90mm truss

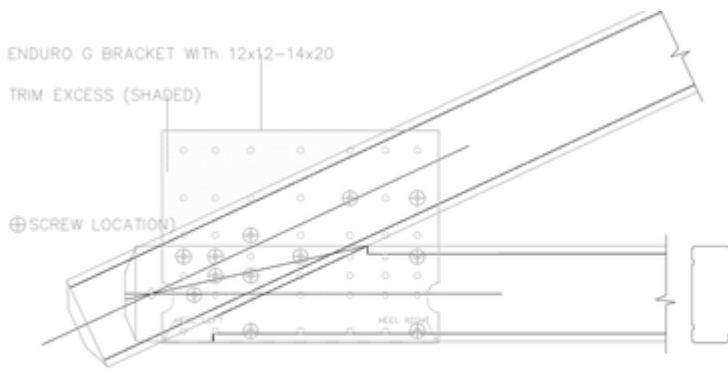
**Heel F2**



**Heel strengthened with CPAH bracket, 25 x 3 x 200mm plate tie or 50 x 50 x 3 x 200mm equal angle tie, and 1.5mm plate with a boxed top chord 100 x 100 x 1.5mm plate for 75mm truss and 125 x 125 x 1.5mm for 90mm truss**

**Heel G**

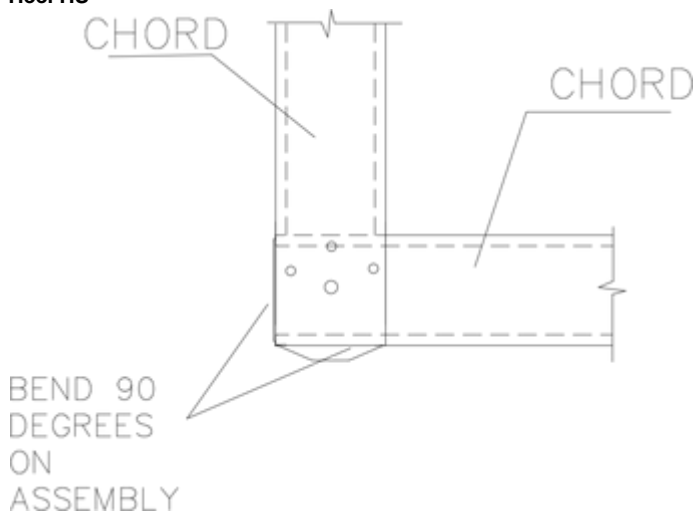




1 TRUSSTITE + 12X12-14X20 HEX SCREWS

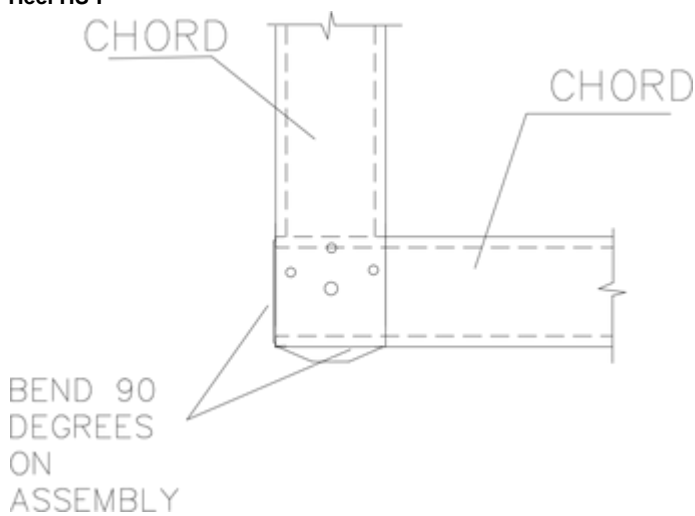
Heel strengthened with Heel-G bracket (200x35x1.5 thk)

Heel HS

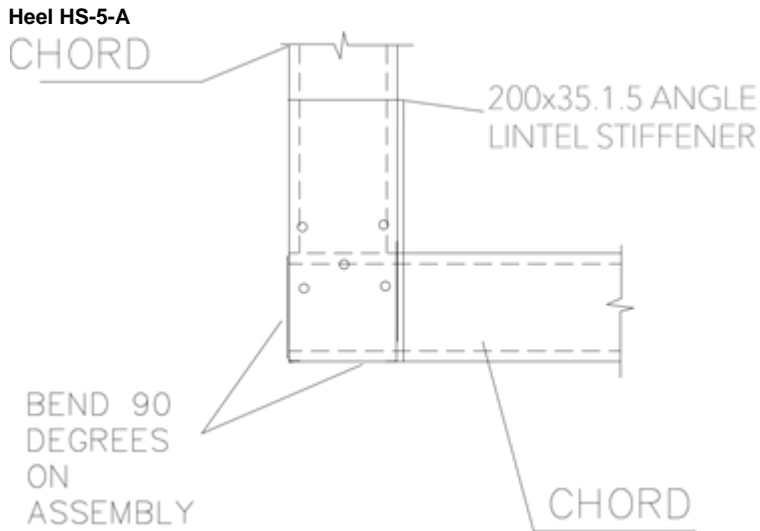


Half Truss Heel where the vertical member is designed as a Chord

Heel HS-F



Half truss Heel where the end member has chord attributes and is flush



**Stiffened version of the HS-F connection using a 200x35x1.5mm lintel section**

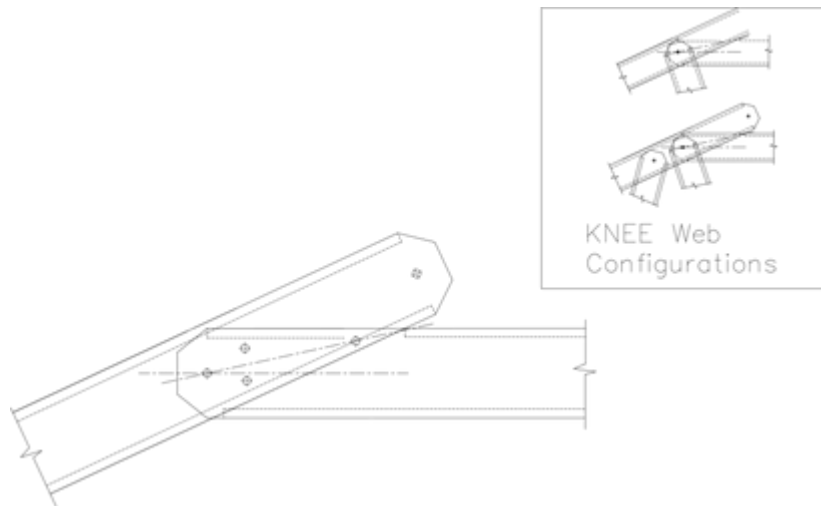
#### 6.6.4 Knee Stiffening

From the appropriate connection drawing, identify the location and type of stiffener and/or the screws required. Install as shown on the drawing.

The 35 x 35 x 200 x 1.0mm angle stiffener is provided for high compression knee connections (Knee Type D) or a 125mm x 125mm x 1.5 mm plate (Knee Type E).

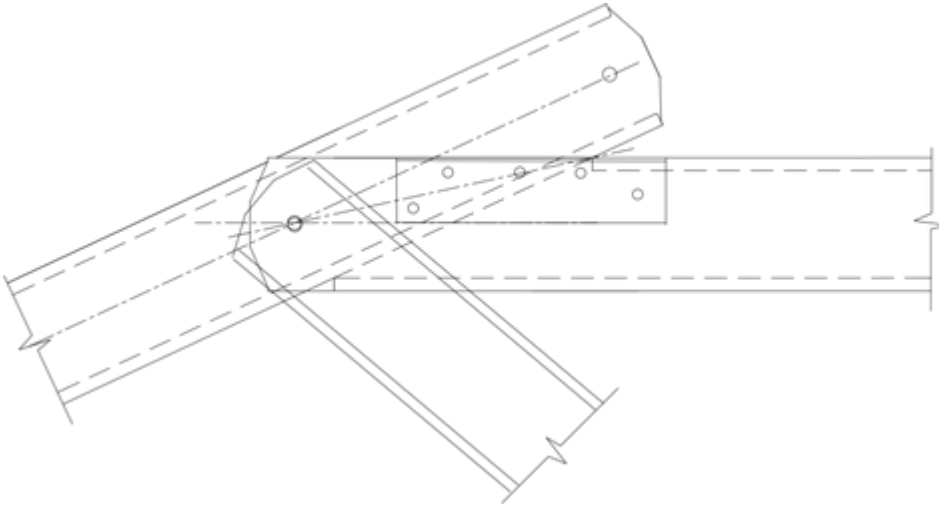
Summary of Knee Stiffeners is below.

#### Knee A



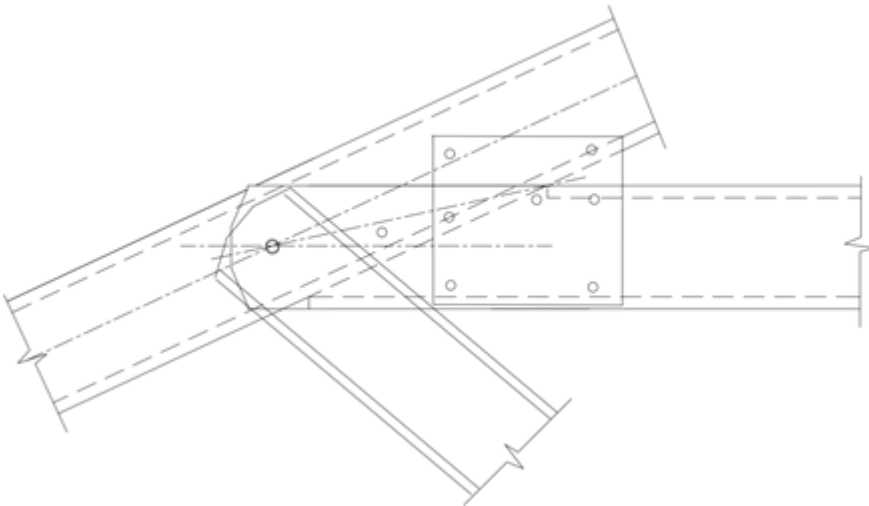
**Unreinforced knee**

**Knee C**



**Horizontal 35 x 35 x 1.0mm angle stiffener, 200mm long**

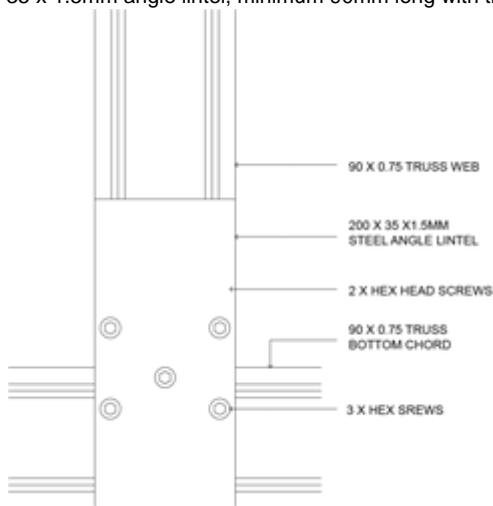
**Knee E**



**Knee strengthened with 1.5mm plate to top chord preventing buckling Use 100 x 100 x 1.5mm plate with 75mm chords Use 125 x 125 x 1.5mm plate with 90mm chords**

**6.6.5 Web Stiffening**

Web stiffening may be required when flush truss is selected to increase the strength of the web in compression. This is done with a 200 x 35 x 1.5mm angle lintel, minimum 90mm long with the nominated number of fasteners into the connection as is shown in the figure below.

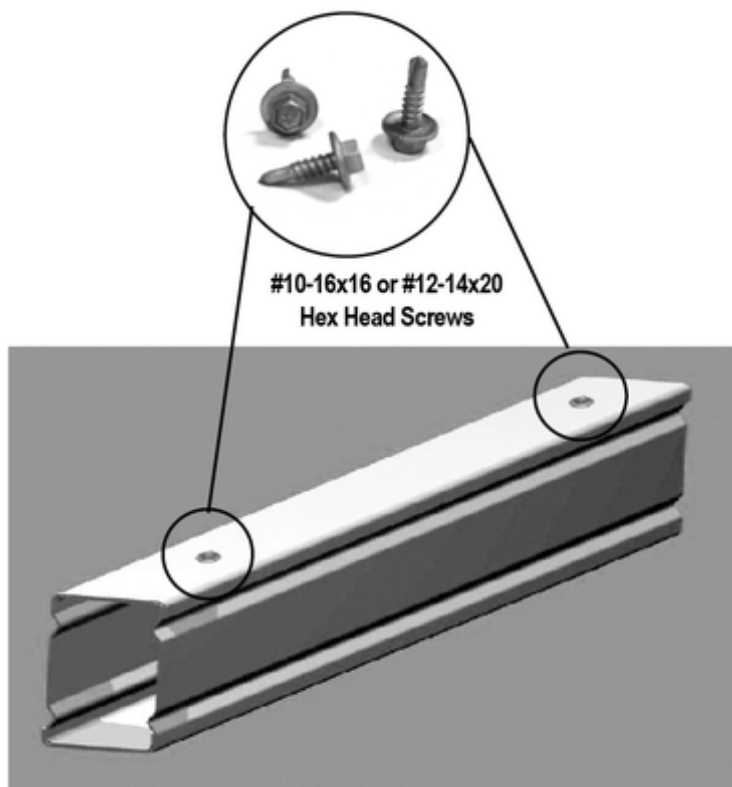


**Figure 6.6 - WEBA Web stiffener**



### 6.6.6 Chord Boxing

Where called for in the Assembly Sheet, chords are to be boxed using supplied boxing channel. Boxing is to be fixed to the inside flanges of chords using either #12-14x20 hex head self drilling screws, 10-16 x 16mm wafer head self drilling screws, or M6,0 x1P x 18,0 Smooth Top Gx Tek's self drilling screws as per the diagram below. These are fixed 50mm from each end of the boxing and at 600 mm nominal centres along the boxing. Where fasteners will be fixed into the flanges of the boxed chords during the installation process in the locations described here (ie. due to the installation of tie down brackets, ceiling or roof battens, etc) they may be omitted during the fabrication process. In this case the fabricator should provide clear instructions to the installer on the required location of screws to meet the boxing requirements.



### 6.6.7 Web Boxing

Where called for in the Assembly Sheet, webs are to be boxed using supplied boxing channel. Boxing is to be fixed to the web using #10-16x16 or #12-14x20 hex head self drilling screws through each flange 50 mm from each end of the boxing and at the centre of the web.

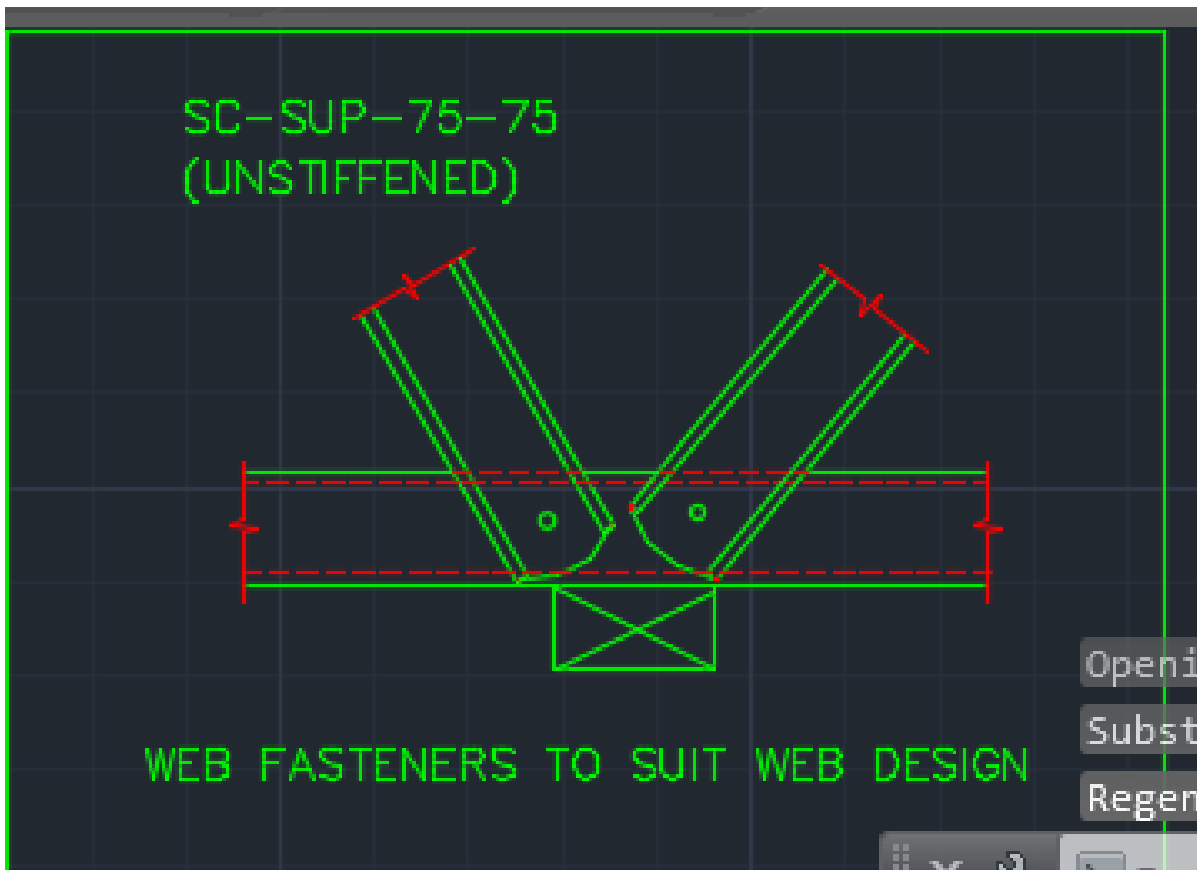
### 6.6.8 Web Supports

There are 3 types of web connections at support points that are used by the ENDUROCADD® software:-

- **SUP connection** - this is used when truss webs are located above an internal load bearing wall or beam, and there is no failure in bearing.
- **SUPA connection** - this is used when truss webs are located above an internal load bearing wall or beam, and increased bearing is required by stiffening the bottom chord with a boxing section which is 250mm long in minimum 0.75mm BMT material
- **SUPB connection** - this is used when a single vertical web is attached back-to-back to a bottom chord. This is automatically inserted by the software when a support point is within 50 - 500mm of a heel connection, or where the user manually inserts a vertical web above a support.
- **SUPB-F connection** - this is used when a single vertical web is attached flush to a bottom chord. This is automatically inserted by the software when a support point is within 50 - 500mm of a heel connection, or where the user manually inserts a vertical web above a support.

#### SUP Connection

The SUP support is used when truss webs are located above an internal load bearing wall or beam and are inclined. In this case the numbers of reinforcing screws are indicated on the truss webs. This connection is used where there is no failure in bearing of the bottom chord.

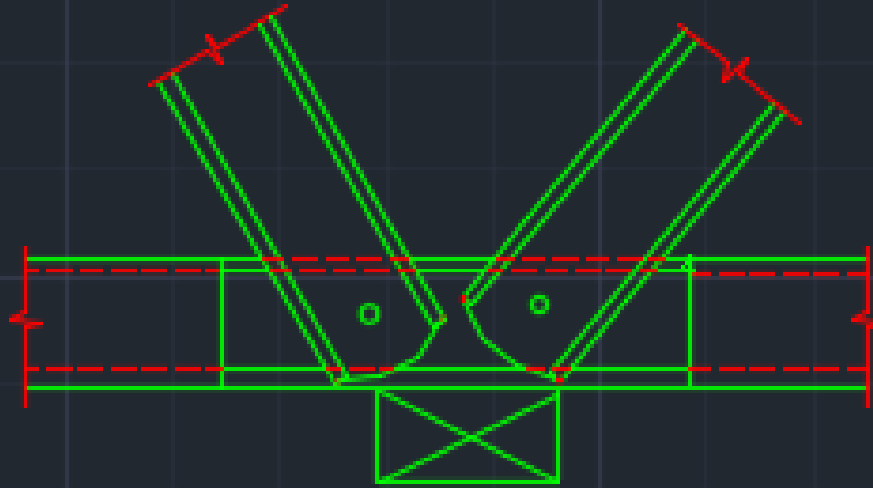


Installers may choose to add a minimum 250mm boxing piece in minimum 0.75mm material onto trusses where there is insufficient space to attach a tie down bracket between the webs. In this case, the boxing piece is attached to the chord using 3 x 12-14x20hex head or 3 x M6x1P flat fasteners on each flange of the boxing piece

#### **SUP A Connection**

The SUPA support is used when truss webs are located above an internal load bearing wall or beam and are inclined, and increased bearing is required by stiffening the bottom chord with a boxing section which is a minimum of 250mm long in minimum 0.75mm BMT material. The number of re-inforcing screws are indicated on the truss webs. This boxing piece is attached to the chord using 3 x 12-14x20hex head or 3 x M6x1P flat fasteners on each flange of the boxing piece. The numerical control data is not generated for production, and is constructed using scrap material. The truss tie down connection may be attached to either face of the truss bottom chord.

SC-SUP-75-75-A  
(STIFFENER 250MM LONG 0.75MM CHANN



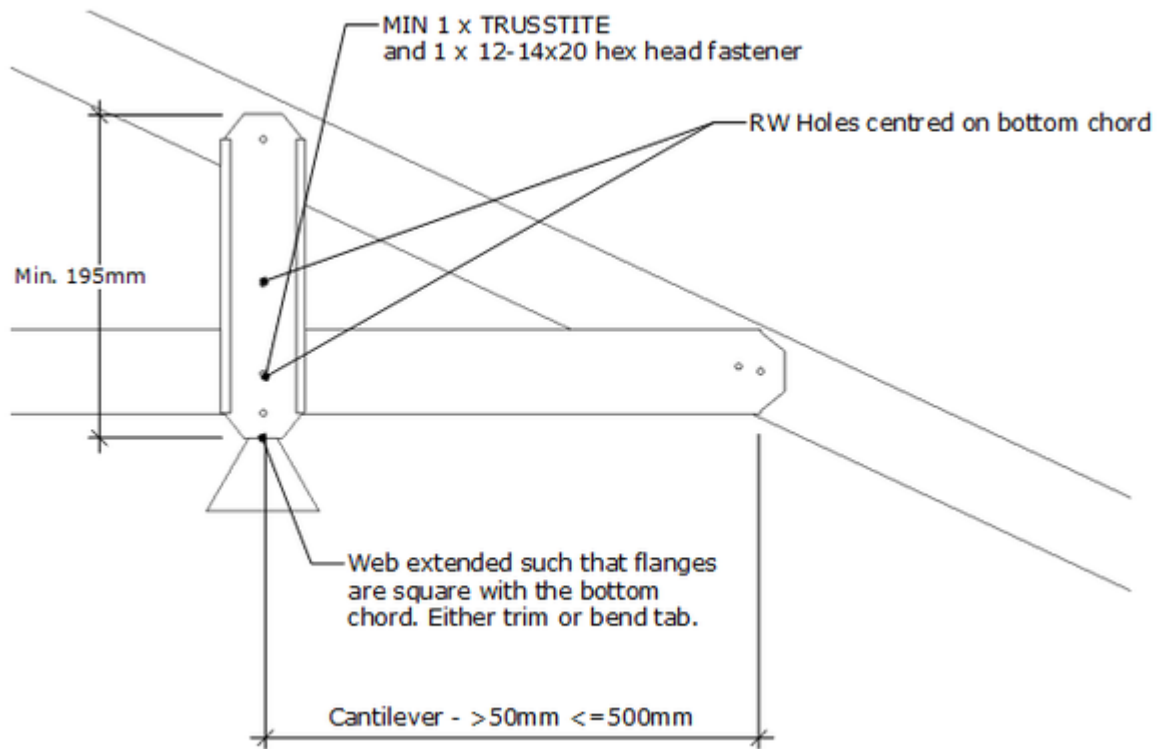
WEB FASTENERS TO SUIT WEB DESIGN

#### SUP B Connection

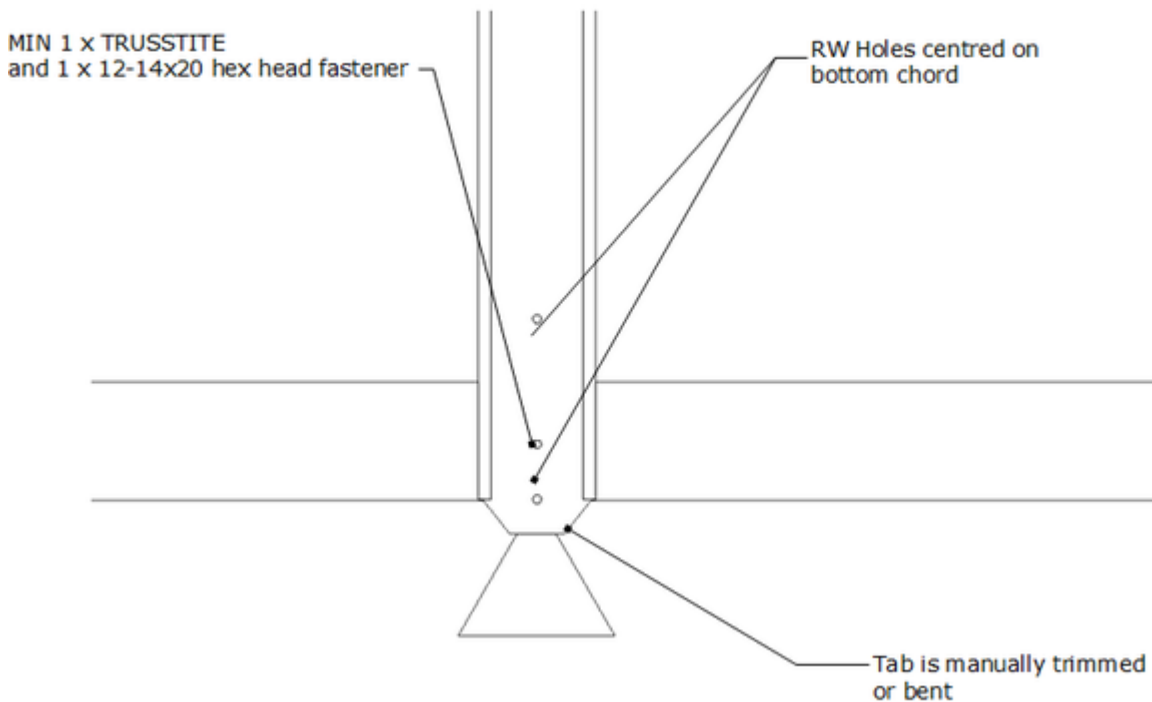
The SUPB connection is used when a support point is between 50 - 500mm of an eave, and the ENDUROCAD® software automatically inserts a back-to-back web. The minimum length of the vertical web is 195mm (if we start at the bottom of the vert web, there is 25 mm tab below the bottom chord, 45 mm up to the trussite (attaching the web to the CL of the bottom chord), 100 mm to the next trussite (attached to the top chord), then 25 mm tab. All add up to 195mm). This is so there is a sufficient space to operate the RW punch for a 90mm section (the punch has holes spaced at 100mm) and still fit within the part length. The tab of the web is extended past the bottom flange of the bottom chord such that the flanges of the web are perpendicular with the bottom flange of the bottom chord of the truss. The truss assembler shall manually bend or cut the tab off the truss.

The number of re-inforcing screws are indicated on the truss webs, however there shall be no fewer than 2 screws in the web to bottom chord connection - 1 x TRUSSTITE and 1 x 12-14x20 hex head fasteners.

The design values for these connections are derived from the HEEL-HS connections.



**SUPB Connection when cantilever is between 50mm - 500mm from heel connection**



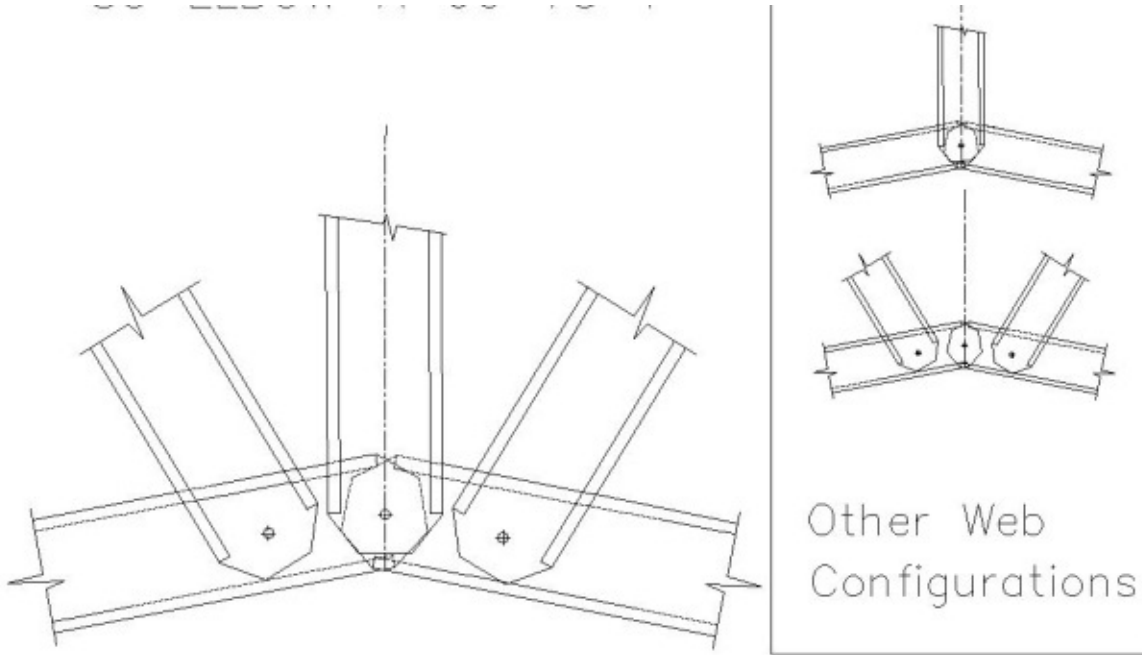
**SUPB Connection when user manually selects to make web vertical above a support point**

**SUPB-F Connection**

This is a variation on the SUPB connection however the web is a flush web. The value for this connection is derived from the HEEL-HS-F connections.

**6.6.9 Elbow Stiffening**

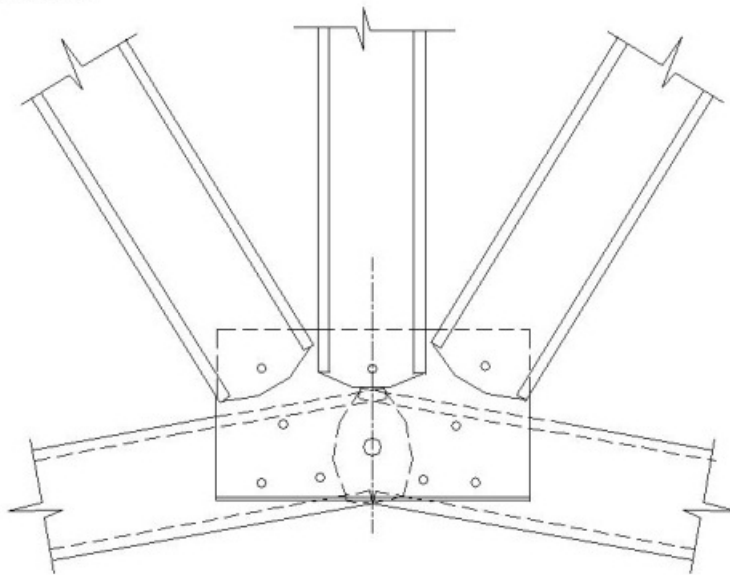
From the appropriate connection drawing, identify the location and type of stiffener and/or the screws required for Elbow stiffening.



### 1 TRUSSTITE to CHORD INTERCEPT

#### Elbow Stiffener A

120mm x 35mm x 1.5mm ANGLE (MIN)  
210mm LONG



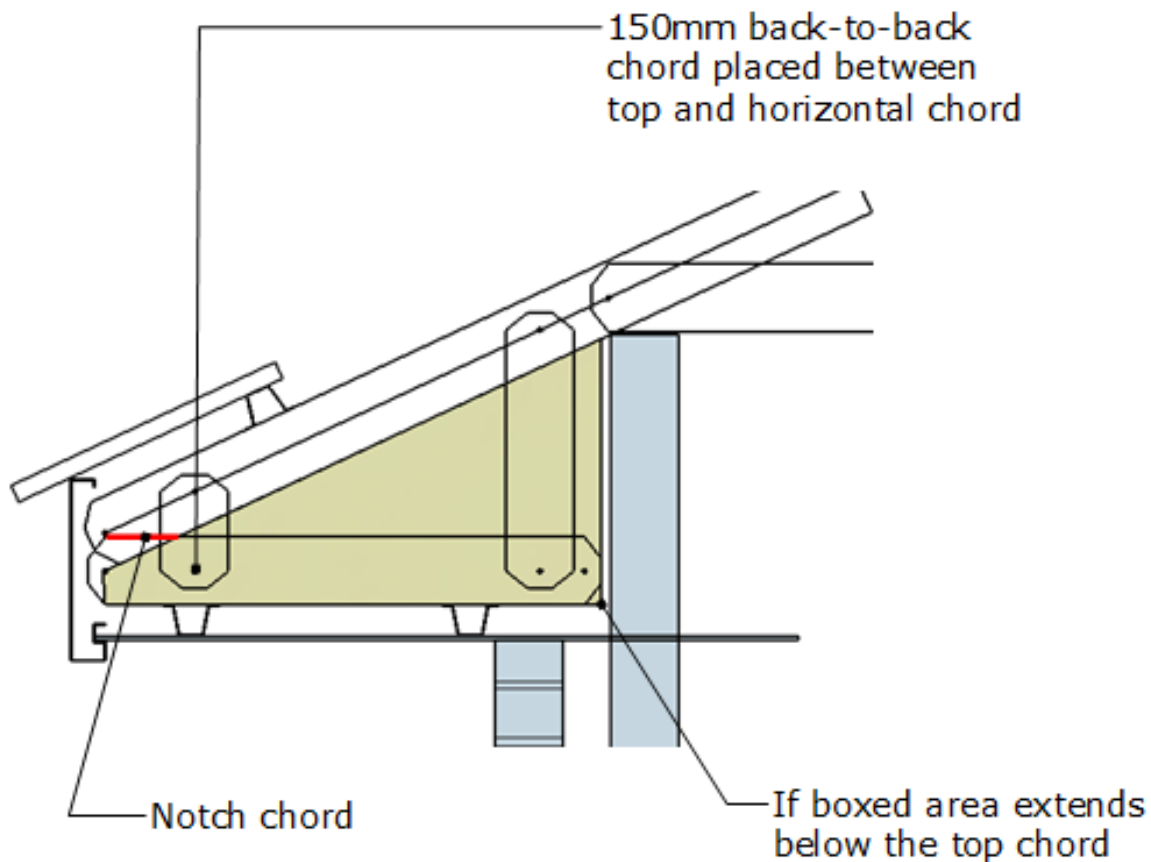
TRUSSTITE + 6X12-14X20 HEX SCREWS

#### Elbow Stiffener C using an Elbow Plate

The detail for the elbow plate is at this link - [Smartruss Elbow Plate P11867.pdf](#)

## 6.7 Boxed Eaves

Boxed eaves can apply to trusses, common rafters or truss hips, and provide supports for the eaves lining. The distance can be adjusted to suit the dropoff height and the distance from the pitching point.



### Boxed Eave Detail

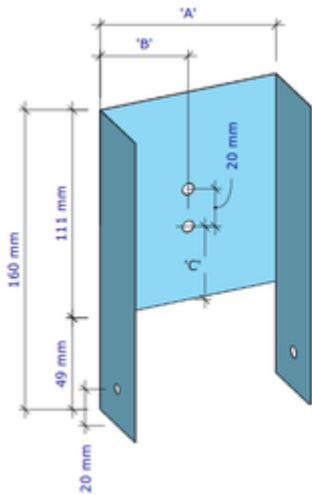
It is possible that locating holes do not line up between the horizontal chord in the boxed eave and the locating hole in the truss top chord. In this case a 150mm long vertical back-to-back web is inserted to locate the position of the horizontal chord. In the event that a flush truss is being used this vertical back-to-back web may be removed and replaced with 2 x 12-14x20 hex head fasteners or a minimum 100 x 100mm plate to keep the bottom chord in place.

## 6.8 Pre-attaching ENDUROGRIP tiedown brackets to truss bottom chords

The ENDUROGRIP tiedown provides an option to pre-attach tiedowns to trusses so the reinforcing screws used in the truss heels can also double up as screws to attach the bracket to the truss. The ENDUROGRIP tiedown is similar to the Transition Part tie down however it has locating holes punched in it which align with holes punched in the bottom chord of trusses. Both the ENDUROGRIP tiedown and punching holes in bottom chords are options which need to be selected by software users in the ENDUROCAD® software in order for these features to appear in the project.

The dimensions of the ENDUROGRIP bracket are shown below:-





**Key Dimensions for ENDUROGRIP Tiedown**

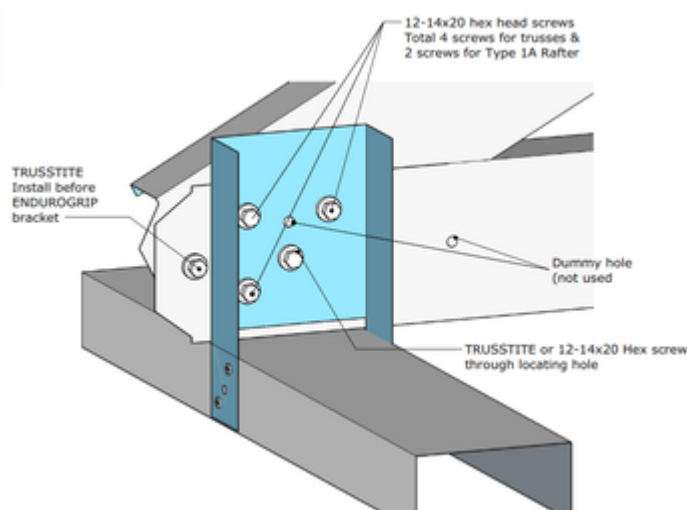
Tiedown Type	Bracket Width - A	Hole distance from web - B	Position C
TD70	73mm	35mm	32mm
TD75	78.5mm	37.5mm	34.5mm
TD90	93mm	45mm	42mm

**ENDUROGRIP dimensions**

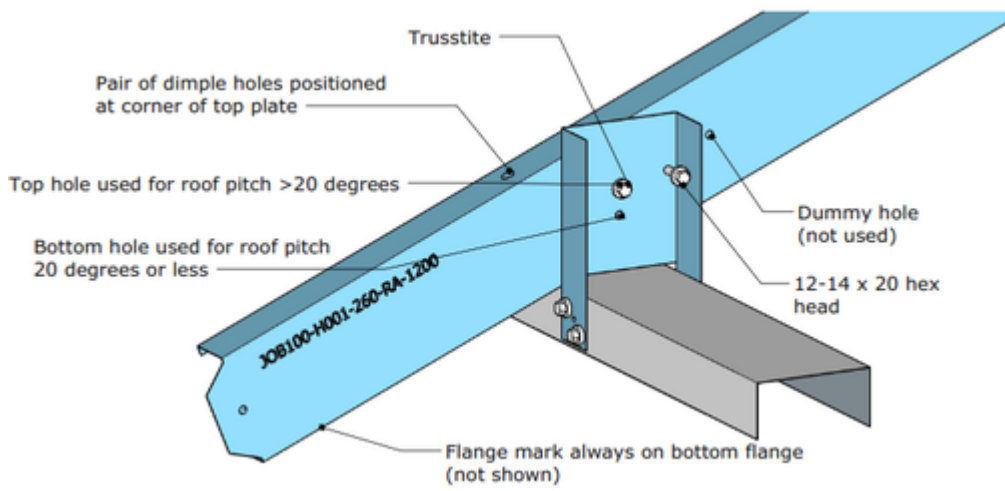
The type of ENDUROGRIP bracket varies depending on the size of the roof truss and the wall frame it is sitting on. The types of ENDUROGRIP brackets are shown in the table below based on the size of the roof truss and wall frame.

Roof Truss Size	Wall Frame Size	ENDUROGRIP Part Code
ENDUROTRUSS 70	ENDUROWALL 70	BRACKET-TD-70W-70T
	ENDUROWALL 75	BRACKET-TD-75W-70T
	ENDUROWALL 90	BRACKET-TD-90W-70T
ENDUROTRUSS 75	ENDUROWALL 70	BRACKET-TD-70W-75T
	ENDUROWALL 75	BRACKET-TD-75W-75T
	ENDUROWALL 90	BRACKET-TD-90W-75T
ENDUROTRUSS 90	ENDUROWALL 70	BRACKET-TD-70W-90T
	ENDUROWALL 75	BRACKET-TD-75W-90T
	ENDUROWALL 90	BRACKET-TD-90W-90T

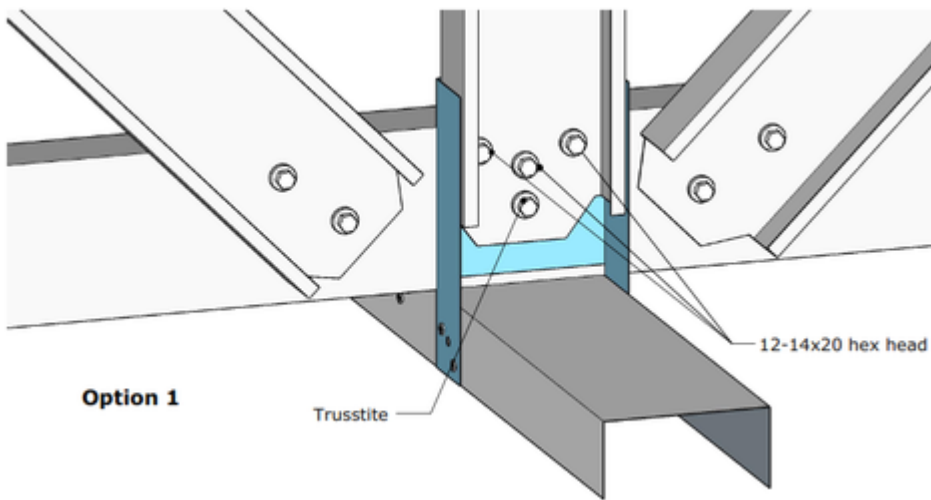
A summary sheet with the fabrication details for the ENDUROGRIP bracket are available at Installation details#ENDUROGRIPFabricationdetails-2pages. Key fabrication details are shown below:-



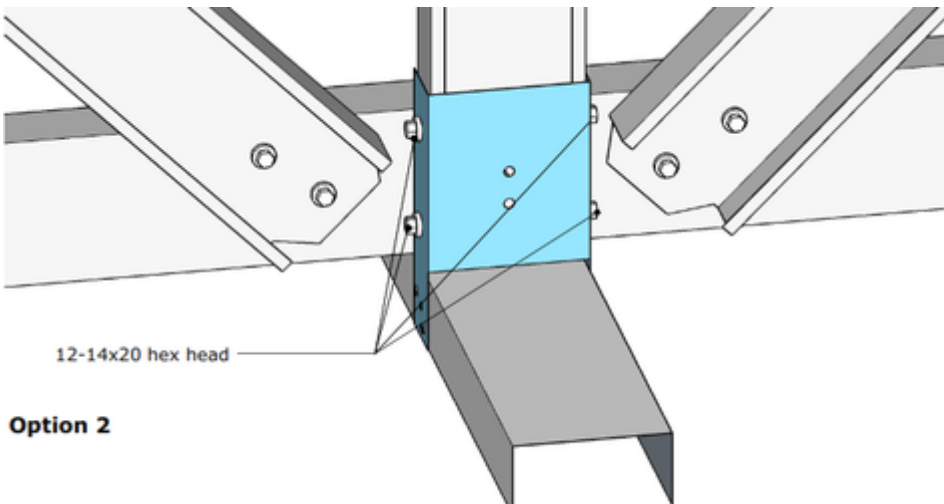
**ENDUROGRIP installation on HEEL-A, HEEL-B, HEEL-E1, HEEL-E2, HEEL-F1, HEEL-F2, HEEL-G (stiffener not shown), Type 1A Hipe End**



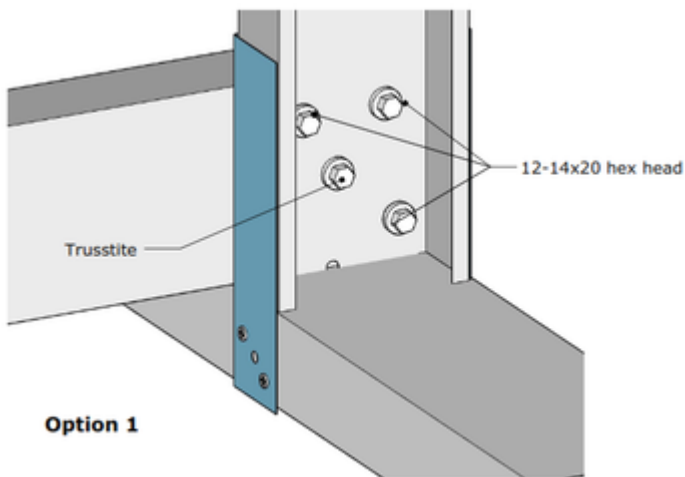
**ENDUROGRIP installation on Type 1 Common Rafter**



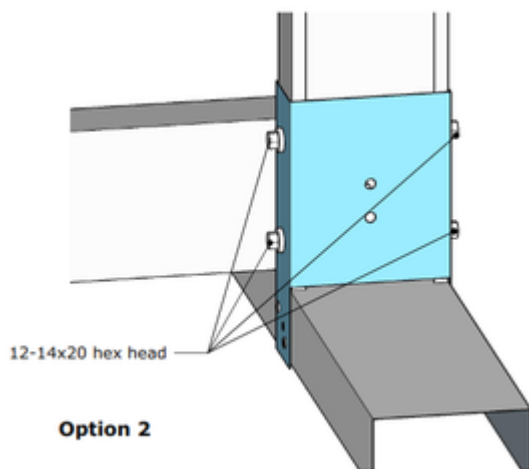
**ENDUROGRIP installation for vertical web over internal load bearing wall - option 1**



**ENDUROGRIP installation for vertical web over internal load bearing wall - option 2**



**ENDUROGRIP installation for HEEL-HS, HEEL-HS4, HEEL-HSF-A, CHORDPT-S, CHORDPT-SF - Option 1**



**ENDUROGRIP installation for HEEL-HS, HEEL-HS4, HEEL-HSF-A, CHORDPT-S, CHORDPT-SF - Option 2**

Where the ENDUROGRIP bracket is used, a minimum of 4 screws are required to attach the ENDUROGRIP bracket to roof trusses, and a minimum of 2 screws for common rafter tie down.

Refer to the connection details for full information on each connection. These images only show the connection of the ENDUROGRIP bracket and do not include any stiffening brackets.

## 7.0 Roof construction

### 7.1 General and design

ENDUROTRUSS® Framing System roof trusses have been designed to engineering standards and it is essential that to perform, as designed, they are handled, erected and braced correctly. The following recommendations apply to roof trusses on standard domestic and light commercial buildings.

The trusses are designed by the ENDUROCAD® design software to suit the specific roof and ceiling geometry and loads applicable site conditions. Additional loading such as Solar Units, Hot Water Tanks, Air Conditioning, etc. require special consideration at the time of design and the placing of these additional loads must be referred back to the designer.

Wind load is an important factor in the design and performance of roof trusses. Ensure that the correct design wind loads have been used and that the tie down of trusses to the wall structure is carried out in accordance with the construction documentation.

#### 7.1.1 Prior to construction

Before commencing roof construction:

1. Check the support structure in particular the plan dimensions, the plumb and level of the support structure, the straightness of the supporting walls or beams and that the structure is adequately braced, stable and tied down. Rectify support structure if found deficient prior to proceeding.
2. Roof trusses must be inspected and any damaged parts must be reported immediately to ensure correct rectification. Approval for site rectification should be obtained from the truss manufacturer.
3. Check that the ENDUROCAD® software generated truss layout matches the building and that all truss set-out dimensions and truss identification marks have been provided.

#### Note

##### Truss orientation and Position

The layout drawings specifies the correct truss orientation. **The front of the truss is the flat (unlipped) face of the truss chord. Looking at the truss from this direction identifies the Left and Right hand truss ends.** Ensure trusses are orientated as shown on the truss layout. Trusses must be positioned within 5mm from their specified position.

##### Roof Truss Numbering

During the detailing / fabrication process the roof trusses are numbered to accurately identify them. These numbers are shown on the roof truss layout and form part of the truss branding (refer Section 6). Trusses may have identical shape but may differ in the web configuration or internal connections. Ensure that the correct truss is used in its specified location on the roof.

##### Safety

Ensure that all barriers or scaffolding used in order to comply with safe work practices are installed so as not to damage or overload roof components.

#### 7.1.2 Trusses above Internal load bearing walls

Where trusses are supported by internal load bearing walls, the truss web configuration will be designed to satisfy the load concentration at the load bearing point. Ensure that the truss is installed such that bottom chord to web connections are within 5mm to the support points. The builder should ensure that these loads are accommodated in the foundation design.

#### 7.1.3 Fasteners

Generally for roof construction #12-14x20mm hex head self-drilling Class 3 screws are used for all structural connections. Use the recommended number shown on the drawings.

In connections, maintain a minimum fastener spacing of 17mm and minimum distance of 17mm to the end of sections and a minimum 10mm from the edge. Refer to **Section 6.5** for a diagram showing locations.

### 7.2 Roof truss set-out

Prior to lifting any trusses into place, mark out the truss locations on the top wall plate, using the supplied Roof Framing Layout as a reference. Layout commences from the outside of the wall panels. The trusses may be aligned to load bearing studs. In cases where it is not aligned, sufficient capacity shall be provided for top plate using lintels or stiffeners. Check that design truss spacings have not been exceeded.

If trusses are fixed to the support structure using brackets these are often installed in the marked positions prior to positioning the trusses.

Alternatively service holes may be punched in the top plate above studs to which trusses are to be fixed. These service holes are to act as location points and allow a 25 x 3 x 200mm tie down strap to fit through and fix to the face of the stud.

It is generally best practice to install Girder trusses and Hip ends before proceeding with the installation of standard truss runs.

Whilst erecting roof trusses ensure that each truss is erected in the correct position, correctly orientated with chords aligned with the roof slopes and plumb (using a spirit level).

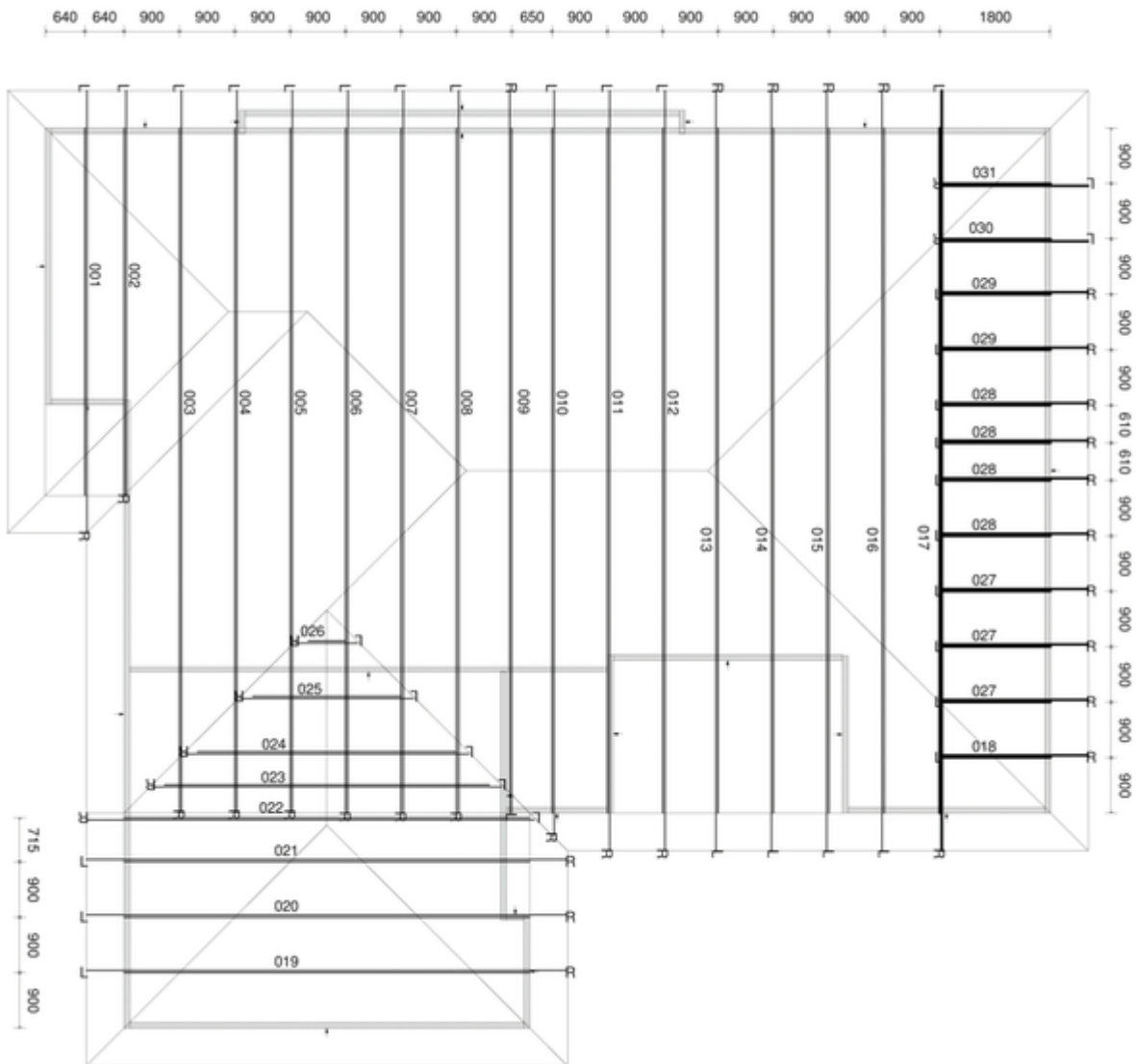


Figure 7.1 Truss layout drawing generated by ENDUROCADD®

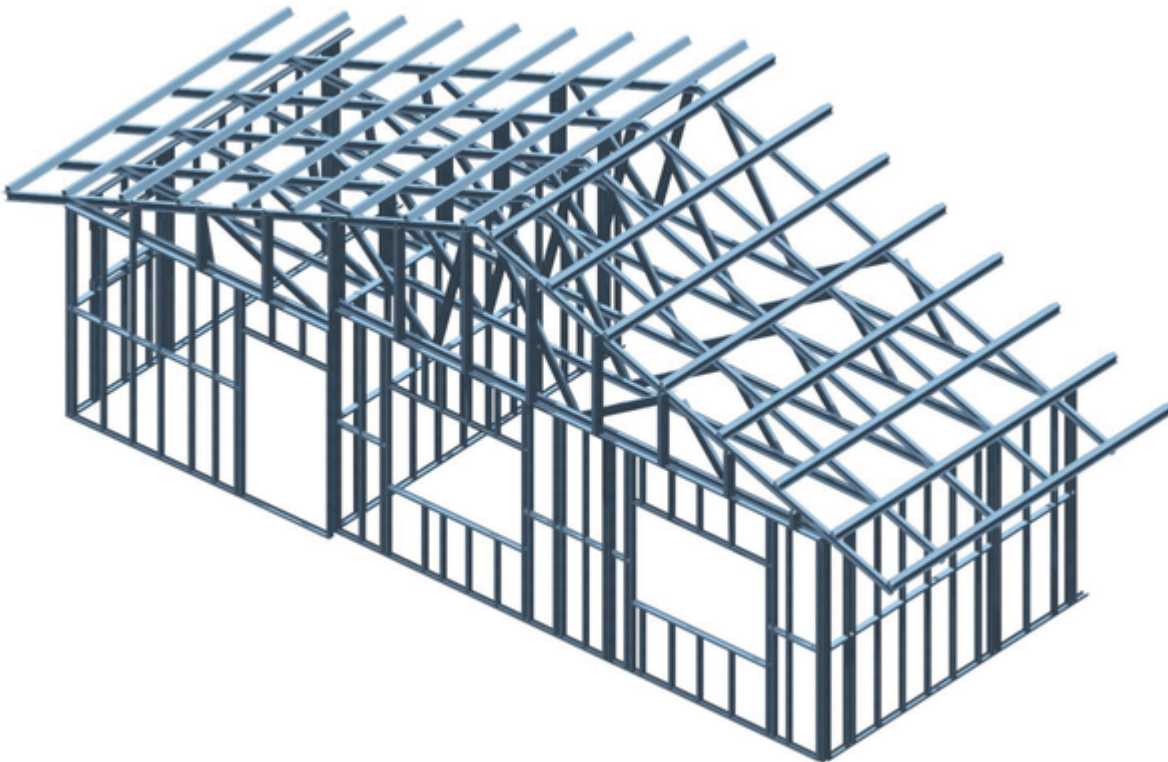
### 7.3 Gable End Construction

Gable ends can be constructed as either:

- **Flush gable ends** where roof battens and end wall cladding is directly supported by either a raking end wall or a truss fitted with cladding support members. See **7.3.1 Flush Gable**.
- **Outrigger gable ends** where outriggers are installed perpendicular to roof trusses and sit on top of truss top chords (or raking walls) above the vertical roof face. See **7.11 Outriggers**.
- **Gable ladder gable ends** where gable ladders (a type of verge overhang built like wall panels) are installed inline with the roof plane and supported by a raking end wall and . See **7.12 Gable ladders**.

#### 7.3.1 Flush Gable

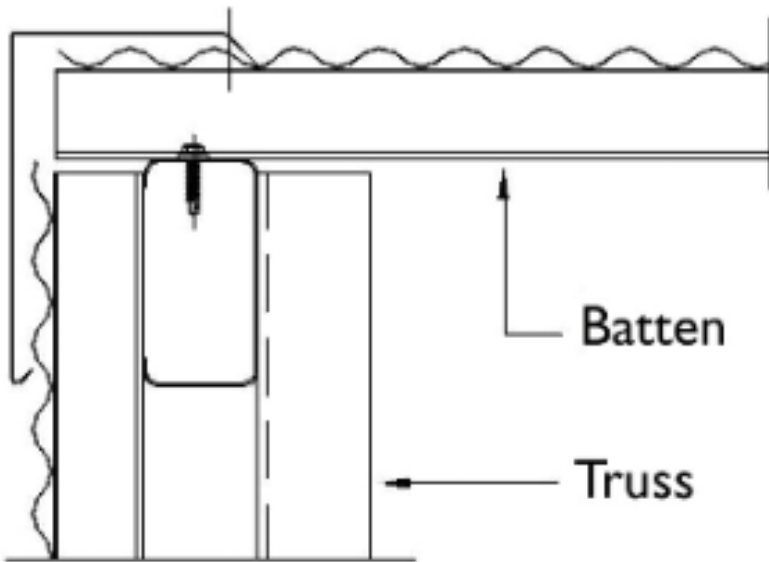
Flush gables support roof battens and end wall cladding directly using either a raking end wall or a truss fitted with cladding support members as shown in **Figure 7.3**.



**Figure 7.3 Framing and truss configuration for a flush gable**

#### 7.3.1.1 Supporting flush gables with gable end trusses

Gable end trusses are usually positioned just inside the end wall to allow the ceiling battens to be fixed directly to the truss bottom chord and framing members are attached directly to the truss outside face to support wall cladding. These framing members may consist of battens or wall studs and must be designed to span between the ceiling plane and the roof plane.

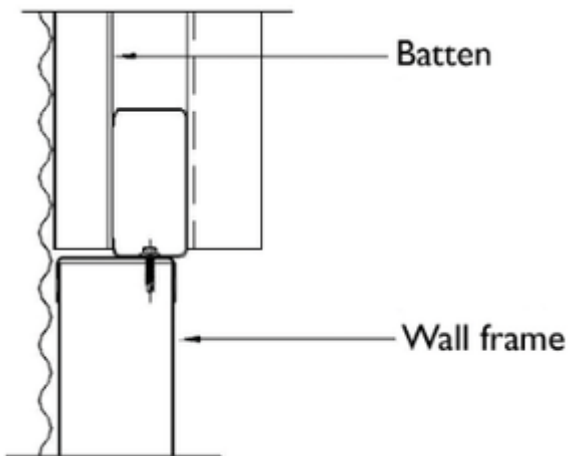


**Note**

**Note:** Temporary bracing should be employed to maintain stability during erection. This ensures the truss is installed plumb and straight and maintains the external cladding line. Refer to **Section 7.9.1** for Temporary bracing.

### 7.3.1.1 Supporting flush gables with raking walls

Raking walls must extend to the roof plane to provide wall cladding support and studs must be designed to span from floor to roof. If there is a ceiling plane below the roof plane then the studs must be fixed so as to transfer end wall wind loads into the ceiling plane. Refer **Figure 7.2** for connection details.





### 7.3.2 Outriggers

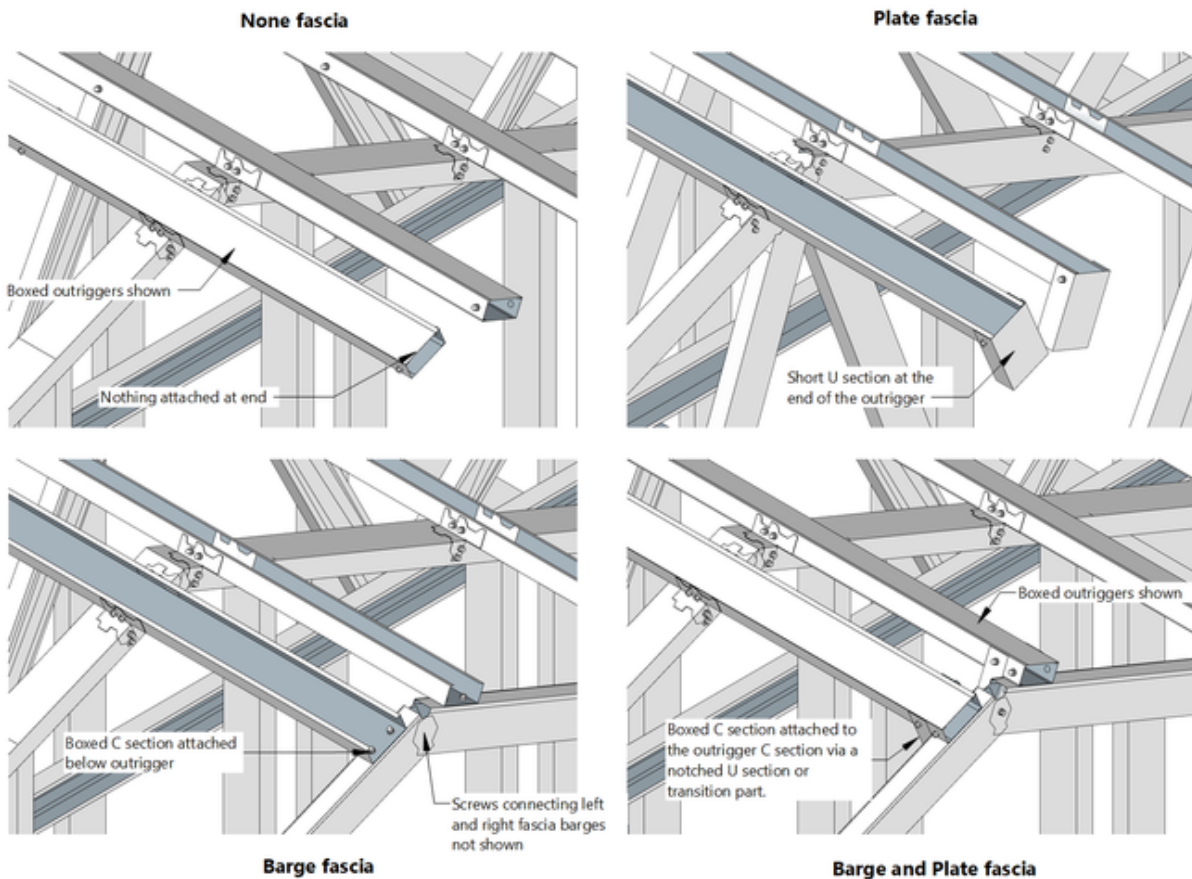
Outriggers are verge overhangs that are perpendicular to roof trusses and sit on top of truss top chords within the roof batten space. They can be used to overhang different types of vertical roof faces including:

- gable roofs
- skillion roofs
- dutch hips
- dormers

Outriggers are the only recommended alternative to build verge overhangs on either dutch hips or dormers

There are four different fascia alternatives for outriggers:

- **None** - no extra parts. Outriggers can be boxed or unboxed
- **Plate** - U section plate part for attaching fascia brackets etc. Outriggers can be boxed or unboxed.
- **Barge** - boxed C section connects outrigger parts at the verge overhang. Outriggers must be unboxed.
- **Plate and Barge** - boxed C section connects outrigger parts at the verge overhang via a U section plate part. Outriggers can be boxed or unboxed.

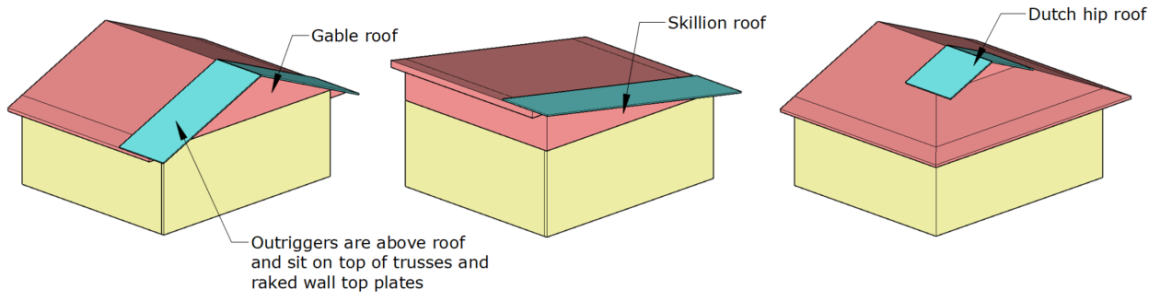


#### Note

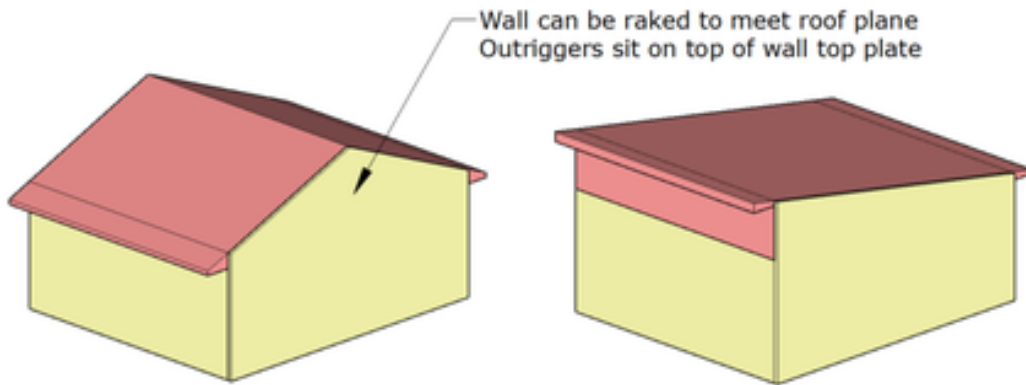
**Note:** Outrigger and barge parts can be fabricated in factory. For ease of transport, barge parts should be attached to outriggers after outriggers are installed onsite.

Outriggers can be supported by either:

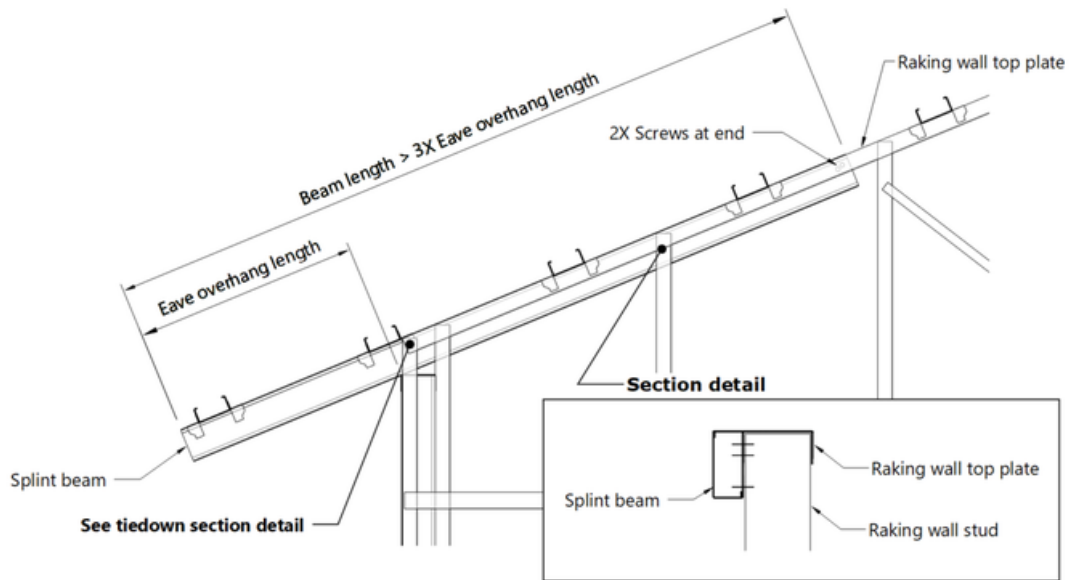
- Trusses



- Raking walls



When using a raking wall to support outriggers you need to provide support at the corners using a splint beam that is attached to the inside of raking wall and cantilevers to the edge of the eave overhang to support the outriggers. The splint beam must extend along the roof at least 3 times the length of the overhang.



### 7.3.2.1 Assembling outriggers

To assemble outriggers:

**Step 1:** Study the outrigger fabrication sheets. Locate the required outrigger set bundle.

**Step 2:** Lift the bundle onto an assembly table and separate the components.

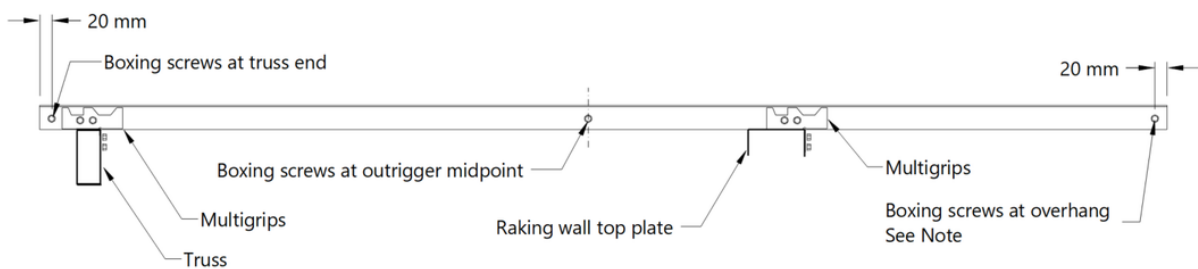
**Step 3:** Lay the outrigger C sections toes up in sequential order as per the assembly sheet.

**Step 4:** Either:

- Outriggers are designed as boxed outriggers. Proceed to the next step.
- Outriggers are designed as unboxed outriggers. Proceed to **Step 7**.

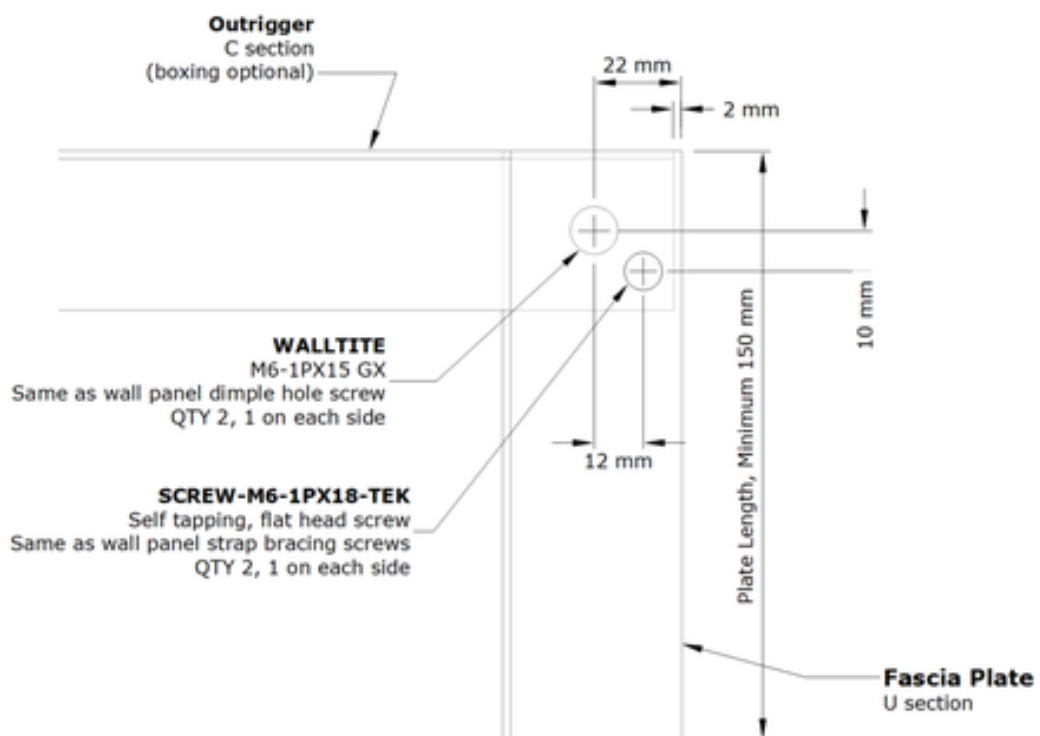
**Step 5:** Box the outriggers using the additional C section boxing pieces.

**Step 6:** Fix a single 10-16x16 hex-head self-tapping screw on each side of the pieces at the midpoint and 20mm from each end as shown below.



**Step 7:** Assemble the fascia. Either:

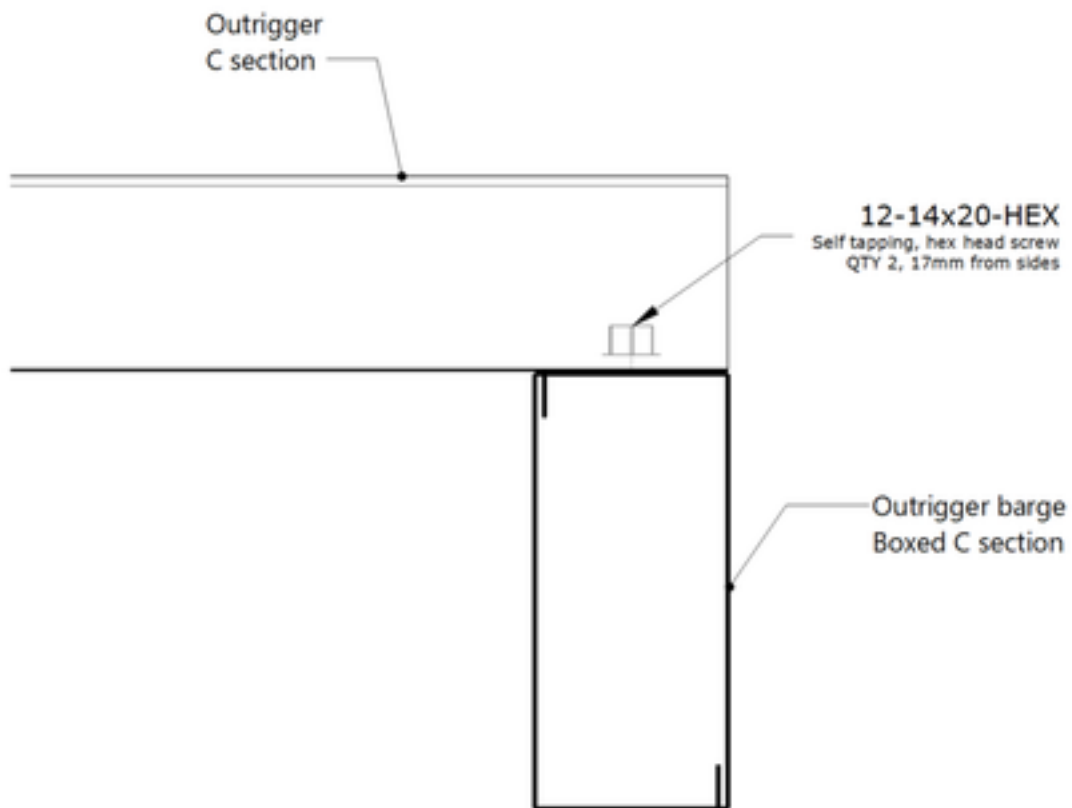
- **None fascia** does not require additional assembly. Proceed to the next step
- **Plate fascia** is assembled by fixing the notched U section to the end of the outrigger at a 90 degree angle using one M6-1PX15 GX Walltite and one M6-1PX18 Tek screw on each side as shown below.



- **Barge fascia** is assembled by boxing the barge fascia pieces then fixing a single 10-16x16 hex-head self-tapping screw on each side of the pieces 50mm from each end and at 600mm nominal centres.

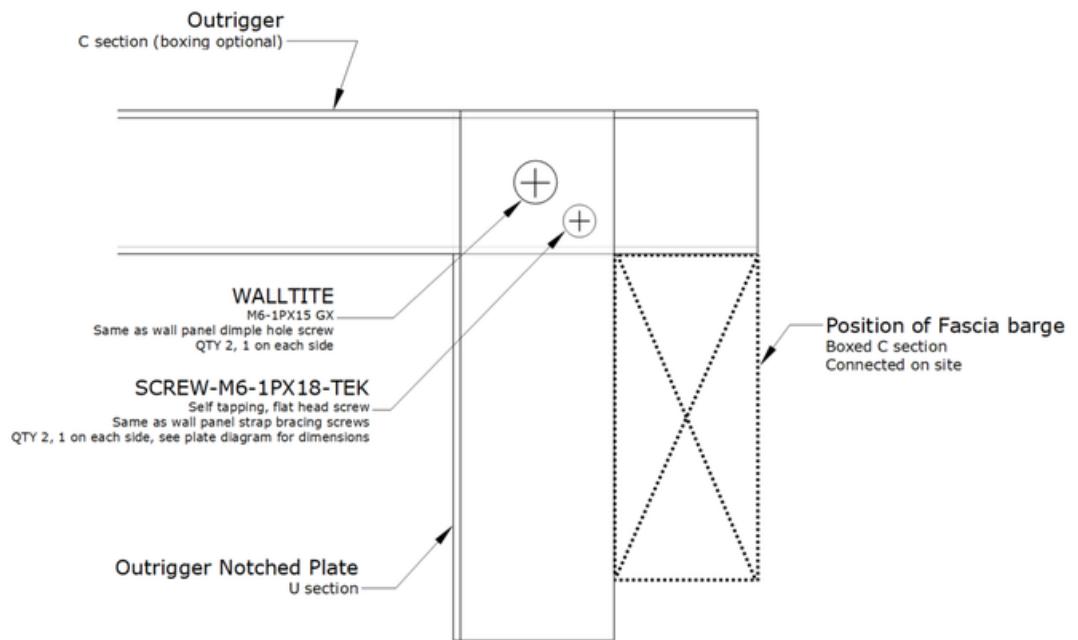
**Warning:** Do not attach the barge fascia to the outriggers at this stage. The barge fascia is attached during installation. See **7.1 1.2 Installing outriggers.**

**Note:** You can only use the **Barge fascia** option with unboxed outriggers because the barge fascia is fixed to the underside of the outriggers as shown below.



- **Barge and plate fascia** is assembled by

- Positioning the notched U section over the end of the outrigger with toes facing inwards
- Moving the notched U section along the outrigger to leave room for the barge fascia
- Fixing the notched U section to the outrigger at a 90 degree angle using one M6-1PX15 GX Walltite and one M6-1PX18 Tek screw (or 12-14x20 hex head fastener) on each side as shown below.



- Boxing the barge fascia pieces then fix a single 10-16x16 hex-head self-tapping screw on each side of the pieces 50mm from each end and at 600mm nominal centres.

**Warning:** Do not attach the barge fascia to the outriggers at this stage. The barge fascia is attached during installation. See 7.1 1.2 Installing outriggers.

Assembling outriggers is complete.

### 7.3.2.2 Installing outriggers

To install outriggers:

**Step 1:** Study the outrigger layout sheets.

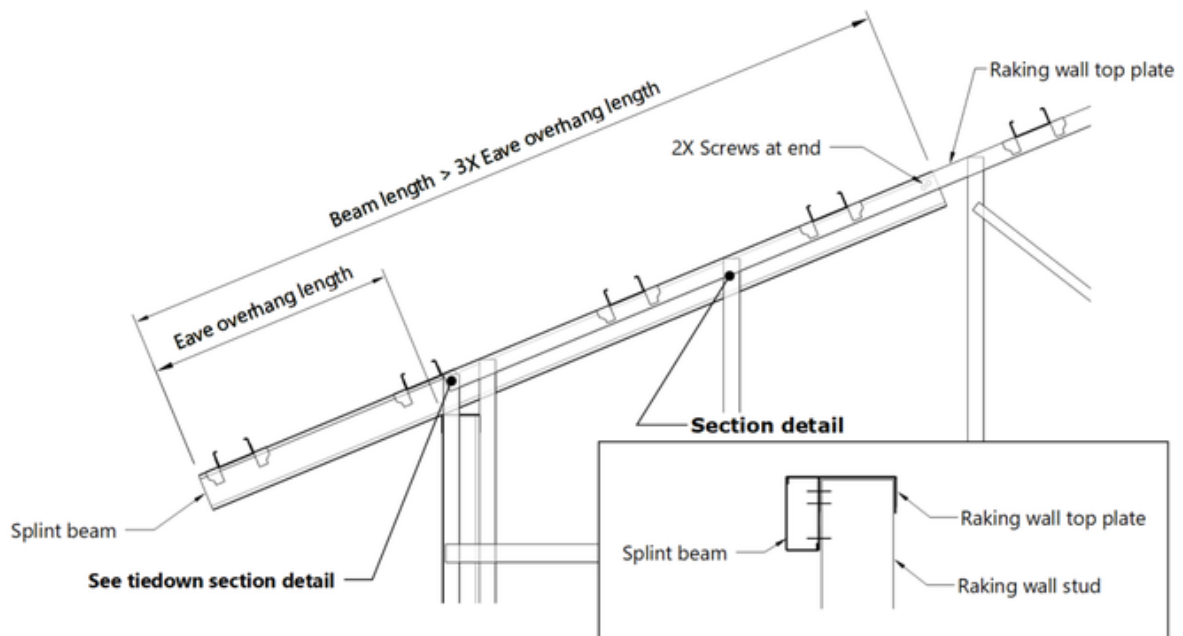
In the outrigger layout sheet, a plan view thumbnail is provided to indicate the overall location of the outrigger set. Verge overhang from the external wall frame is indicated near the thumbnail.

An elevation view indicates the location of each Outrigger on the roof face. Outriggers are dimensioned centre to centre. Dimensions are aligned with the roof face and start from the lowest of the roof face (eave end).

**Step 2:** Set out and mark the outrigger positions including the position of the splint beam, if the outriggers are supported by a raking wall.

You can determine the correct outrigger alignment using the dimensions provided on the outrigger layout sheets.

**Step 3:** If the outriggers are supported by a raking wall, position the splint beam at its marked position in line with the edge of the eave overhang as shown below. Otherwise, proceed to **Step 5**.



**Step 4:** Connect the splint beam to the inside of raking wall using two 12-14x20 hex head self-drilling screws at each end and at maximum 450mm centres along the length of the beam.

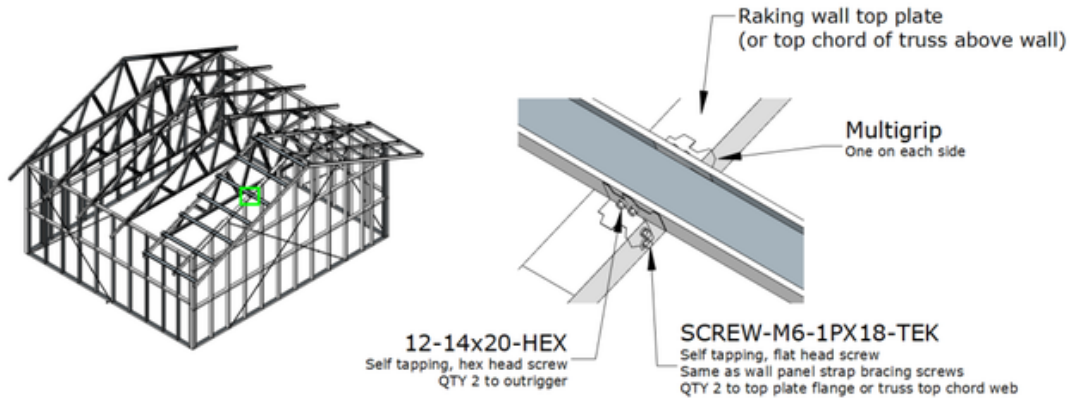
**Step 5:** Position the first outrigger at its marked position.

**Step 6:** Install the first outrigger at its marked position.

- At the **external truss, raking wall or splint beam**, you must install one Multigrip either side of the outrigger (two in total) using:

- Two 12-14x20 hex head self-drilling reinforcing screws to connect each Multigrip to the Outrigger C section

- Two M6x18GX Tek's smooth top self-drilling reinforcing screws to connect each Multigrip to the external truss top chord flange, raking wall top plate flange or splint beam web.



• At **internal trusses** you can install:

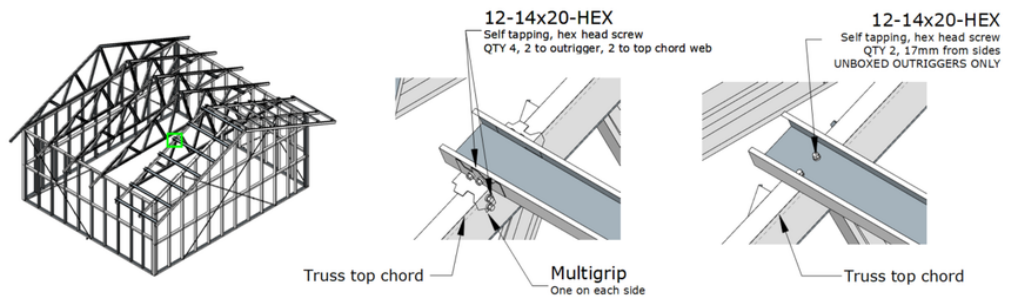
- **Direct screws:** two 12-14x20 hex head self-drilling reinforcing screws per connection to fix the web of the outrigger to the top chord flange of the trusses.

- **Multigrips:** one Multigrip either side of the outrigger (two in total) using:

- Two 12-14x20 hex head self-drilling reinforcing screws to connect each Multigrip to the Outrigger C section

- Two 12-14x20 hex head self-drilling reinforcing screws to connect each Multigrip to the truss top chord web.

Direct screws can only be used for unboxed outrigger-to-truss connections. Multigrips must be used for boxed outrigger-to-truss connections.



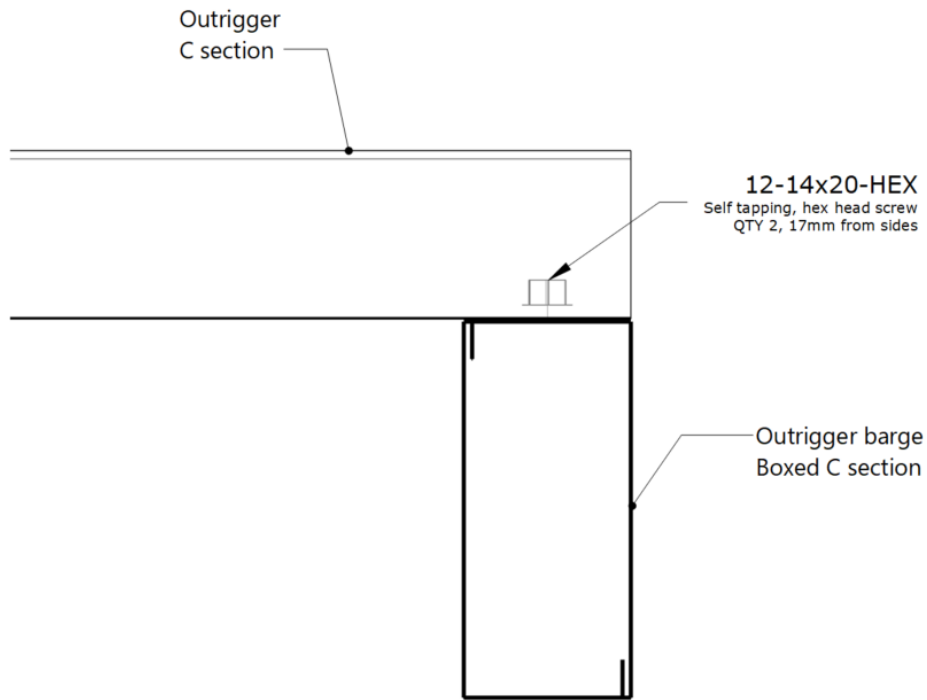
**Step 7:** Repeat the previous step until all outriggers are installed in the marked positions.

**Step 8:** Position the barges underneath the outriggers, if you are using barges. Otherwise, proceed to **Step 11**.

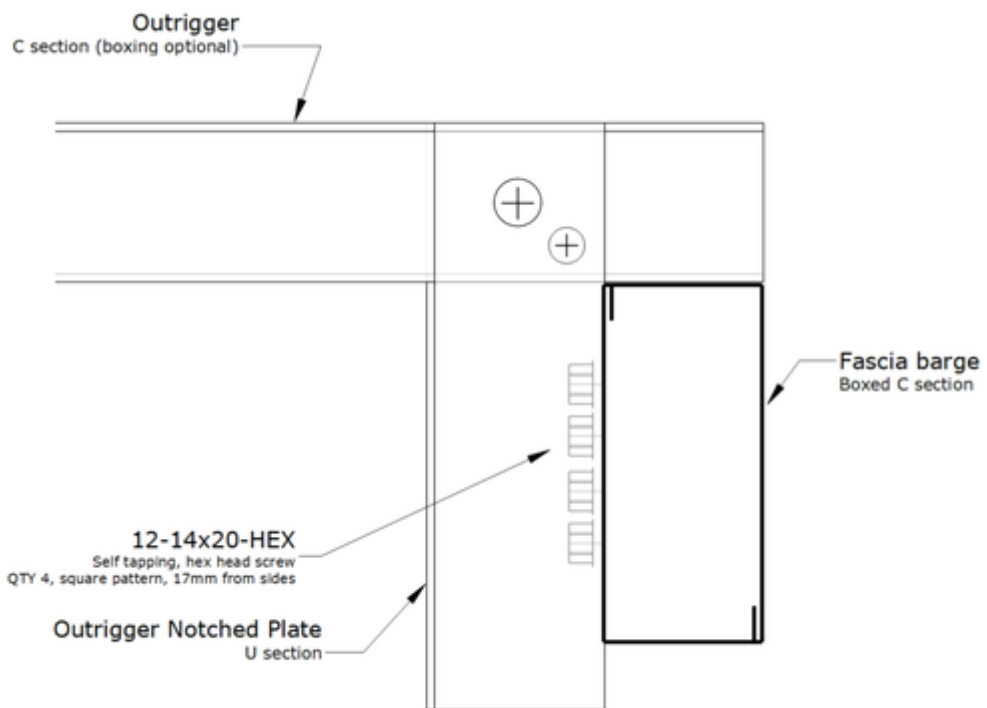
**Step 9:** Fix the barges to the outriggers, if you are using barges. You can fix:

• **Barge fascia** using two 12-14x20 hex head self-drilling reinforcing screws at each outrigger as shown below.

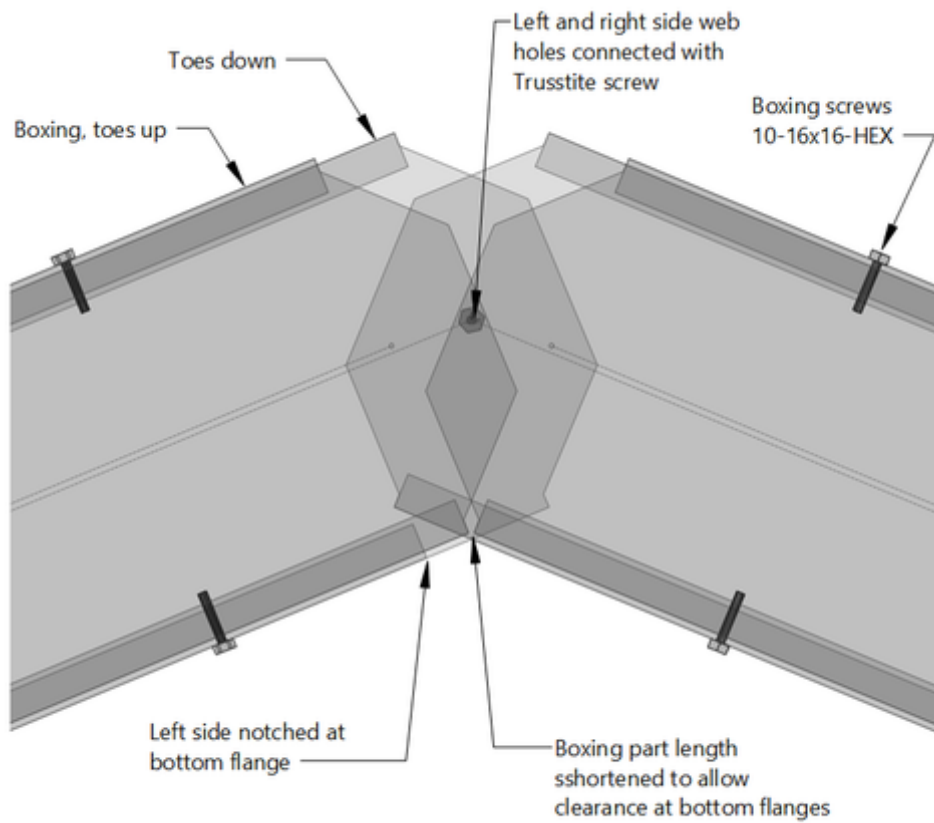




- **Barge and plate fascia** using four 12-14x20 hex head self-drilling reinforcing screws through the notched U section plate at the end of each outrigger as shown below.



**Step 10:** If barges are connected at an apex of a gable roof, connect the barges through the hole at the apex using a single Trusstite screw (the same as you would connect top chords at the apex of a standard truss).



**Warning:** You must complete the remaining steps below during roof batten and roof cladding installation to connect roof cladding to outriggers. Please refer to roof cladding and roof batten suppliers for connection methods and capacity requirements.

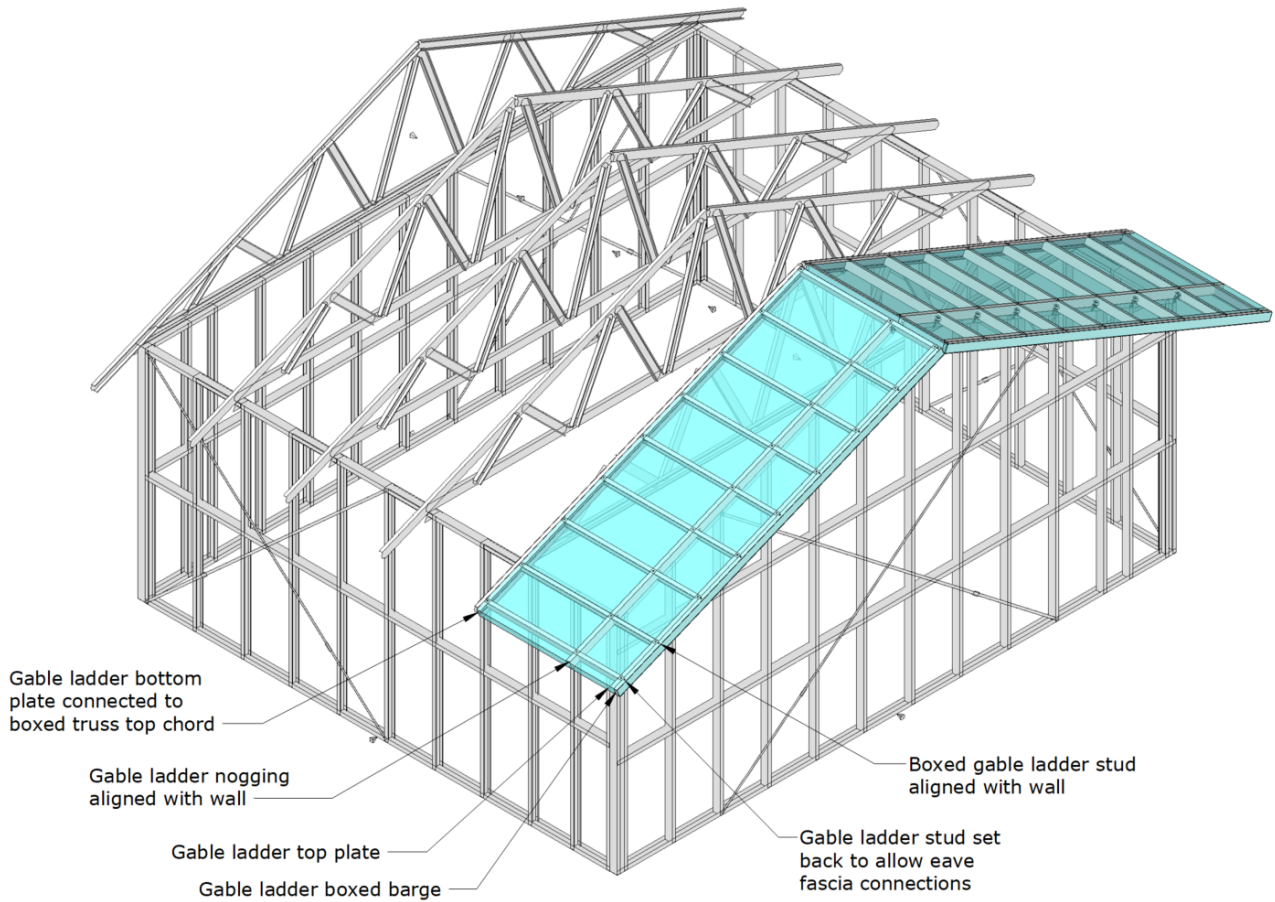
**Step 11:** Connect the roof battens to the outriggers. See 7.11.3 *Roof battens and spacings (below)*.

**Step 12:** Connect the roof cladding to the roof battens using the chosen connection method.

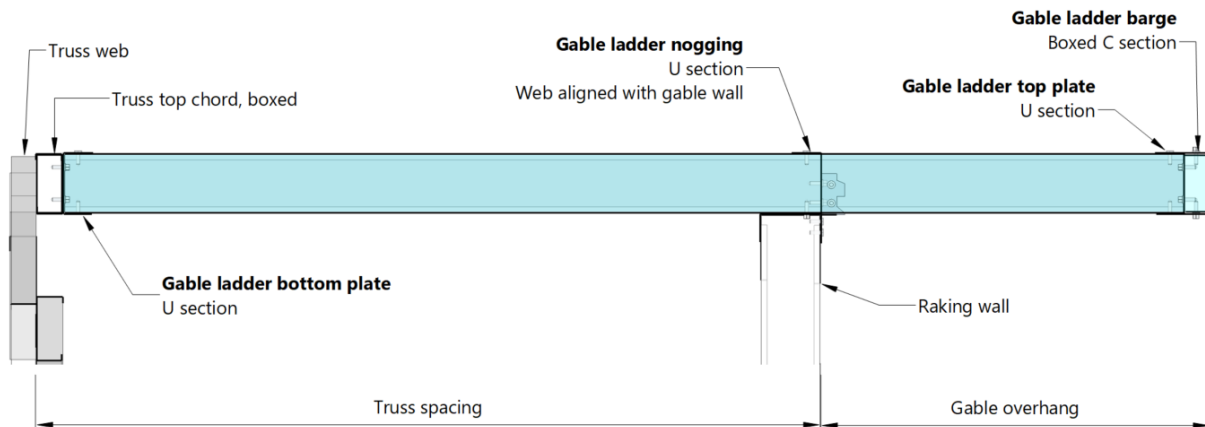
Installing outriggers is complete.

### 7.3.3 Gable ladders

Gable Ladders are a type of verge overhang built like wall panels, with a bottom plate, top plate, noggings, studs and bracing.



Please review the following figure and read the key points below before proceeding with installation:



- Gable ladders are installed inline with the roof plane and the front face of the gable ladder faces upwards.
- Gable ladders must be supported by both a raking end wall that is offset by the section thickness of the gable ladder (70mm, 75mm or 90mm) and an end truss built with boxed top chords that face the end of the roof to provide fixing points for the gable ladder.
- Gable ladders are orientated with the bottom plate attached to the end-most roof truss and the top plate at the verge overhang end of the roof
- Gable ladder nogging web lines up with the external face of the raking wall.

**Warning:** Gable ladders cannot be used for Dutch hip roofs. Outriggers should be used where you are installing a Dutch hip that requires a verge. See 7.11 Outriggers.

**Warning:** Gable ladders may have strap bracing specified. This bracing is only provided to aid transport and installation. It does not contribute to wind bracing.

### 7.3.3.1 Assembling gable ladders

To assemble a gable ladder:

**Step 1:** Study the Gable ladder's fabrication drawing. Locate the required gable ladder stud and nogging/plate bundle.

**Step 2:** Lift the bundle onto an assembly table and separate the components.

**Step 3:** Lay out the gable ladder studs in sequential order as per the assembly sheet.

**Step 4:** Slide the gable ladder nogging onto the gable ladder studs and position as per the assembly sheet.

**Step 5:** Align the holes of the gable ladder nogging with the holes on the gable ladder studs.

**Step 6:** Fix the gable ladder nogging to the gable ladder studs using M6-1Px15 GX Walltite fasteners.

**Step 7:** Insert each gable ladder stud into the top plate.

**Step 8:** Align the holes of the gable ladder studs with the holes on the top plate.

**Step 9:** Fix the gable ladder studs to the top plate using M6-1Px15 GX Walltite fasteners.

**Step 10:** Insert each gable ladder stud into the bottom plate.

**Step 11:** Fix the gable ladder studs to the bottom plate using M6-1Px15 GX Walltite fasteners.

**Step 12:** Flip the panel over and fix the reverse side.

**Step 13:** Fix the barge sections together using two 10-16x16 Hex self-tapping screws at each end and along the length of the barge at 600mm nominal centres.

**Step 14:** Fix the boxed barge section to the top plate of the gable ladder using two 12-14x20 Hex self-tapping screws at each gable ladder stud.

**Step 16:** Repeat this process to assemble additional gable ladders as required.

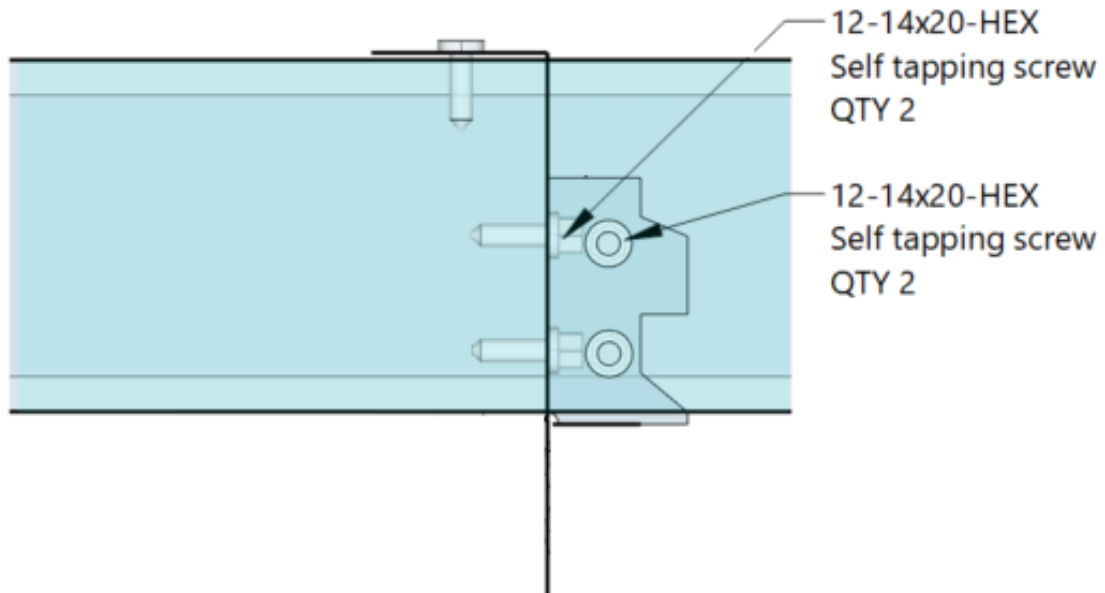
Assembling gable ladders is complete.

### 7.3.3.2 Installing gable ladders

To install a gable ladder:

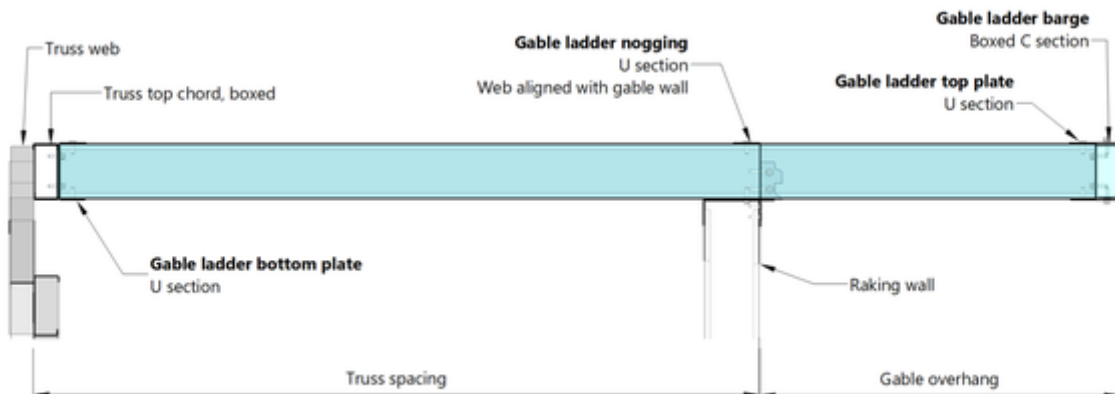
**Step 1:** Study the entire set of architectural and fabrication drawings.

**Step 2:** Attach the Multigrip tie-down brackets at the marked positions on the gable ladder using two 12-14x20 hex self-tapping screws at each connection as shown below.



**Step 3:** Set out and mark the gable ladder positions.

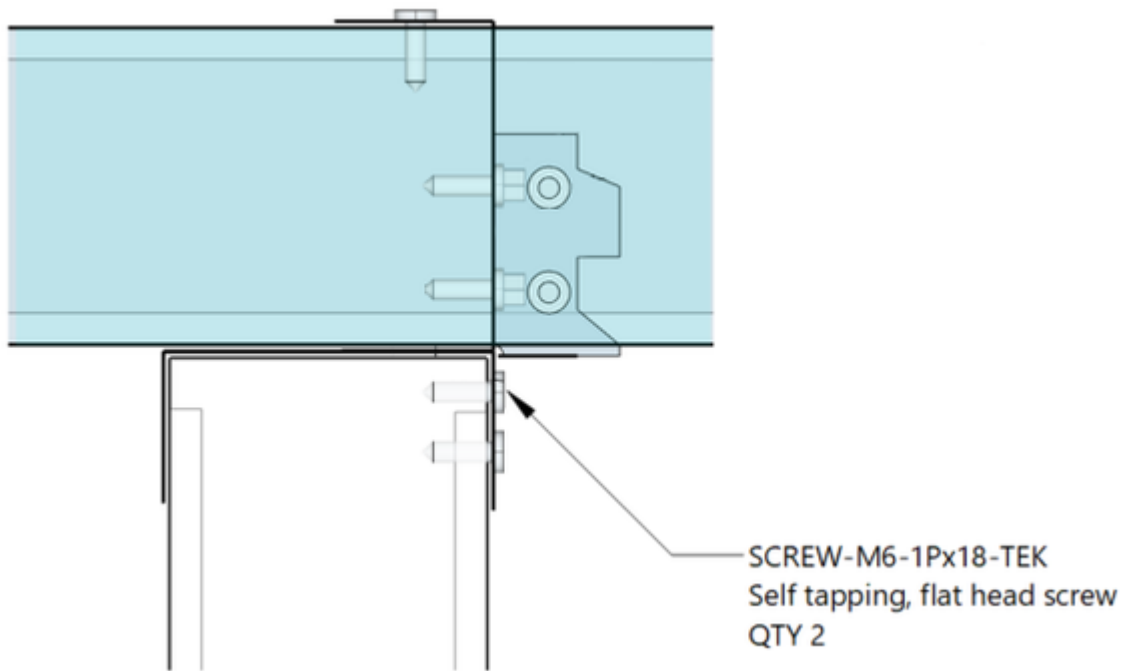
**Step 4:** Lift the gable ladder into position as shown below.



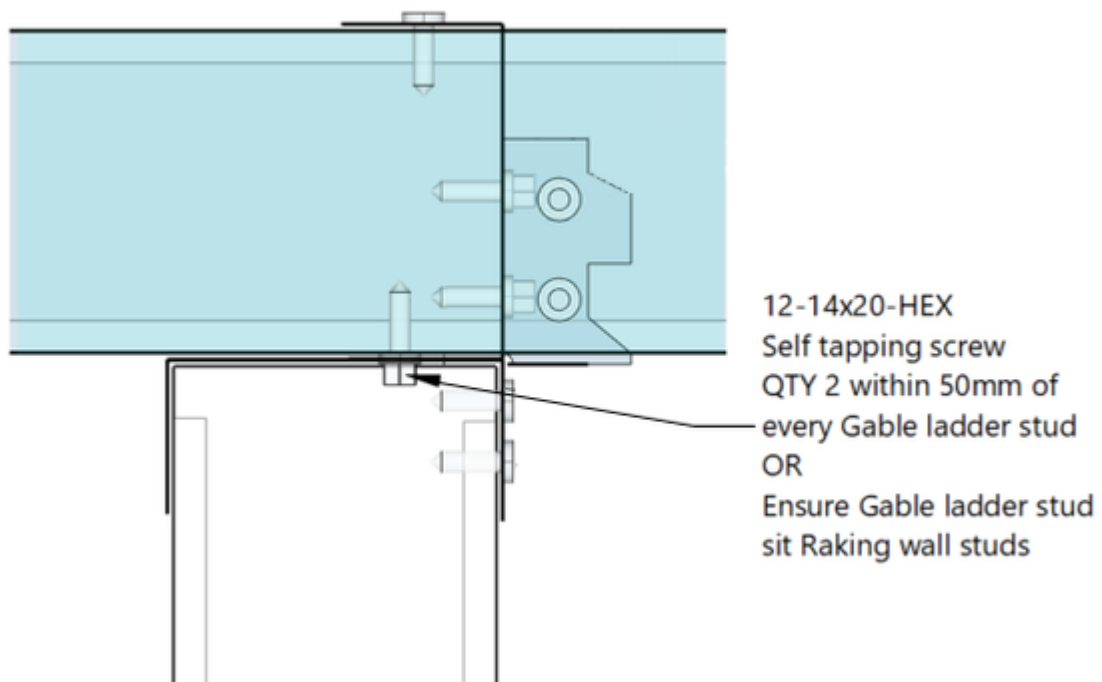
You must ensure that:

- front face of the panel faces upwards
- bottom plate faces the end truss
- nogging is aligned with the external face of the raking wall.

**Step 5:** Fix the Multigrip tie-down brackets to the raking wall using two M6-1Px18-TEK screws for connection as shown below.



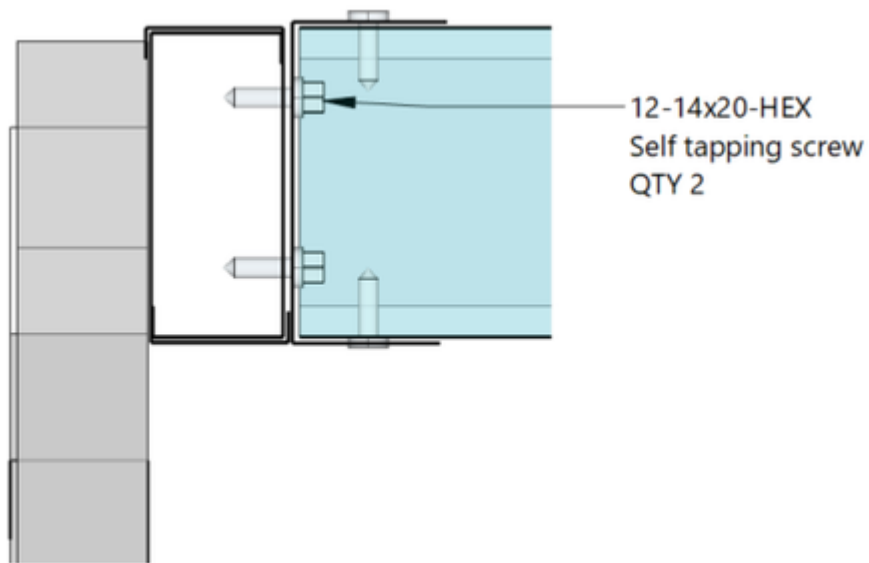
**Step 6:** Fix the gable ladder nogging to the raking wall by fixing two 14-12x20-HEX self-tapping screws through the top plate of the raking wall within 50mm of every gable ladder stud as shown below.



**Tip**

**Tip:** You do not need to complete this step when the gable ladder and raking wall studs are aligned. The Multigrip connection is sufficient.

**Step 7:** Fix each gable ladder stud to the boxed top chord of the end truss using two 14-12x20-HEX self-tapping screws at each connection as shown below.



**Step 8:** Repeat this process to install additional gable ladders as required.

**Step 9:** Connect the roof battens to the gable ladders. See 7.11.3 *Roof battens and spacings (below)*.

**Note:** Gable ladders are in line with the roof plane. Roof battens continue from trusses over the gable ladder, and are fixed to the gable ladder following the batten manufacturer's fastening recommendations.

**Step 10:** Connect the roof cladding to the roof battens using the chosen connection method.

Installing gable ladders is complete.



## 7.4 Hip End Construction

The ENDUROFRAME system provides multiple options for hip roof construction with 3 options for construction of common (sometimes referred to as 'jack') rafters and 3 options for hip rafters. Combinations of each of these can also be selected.

The three options are available for hip end construction:

- Type 1
- Type 1A
- Type 2.

Each option has different configurations for trusses and rafters although the general assembly method is the same. There are also two options for hip rafter construction which can be used with each of the hip end and rafter construction methods. A description of these hip end construction options and how they are installed is described in **Sections 7.4.1, 7.4.2 and 7.4.3.**

### 7.4.1 Type 1 Hip construction

Type 1 Hips use single common rafters that may be boxed and run from the eaves to the hip rafter. Toes on common rafters face towards the center of the building.

A simple 1 page installation drawing that can be sent to site showing how to install Type 1 hip end rafters with a boxed hip is available at [Installation details#HipEndInstallation](#) and is also shown below:-

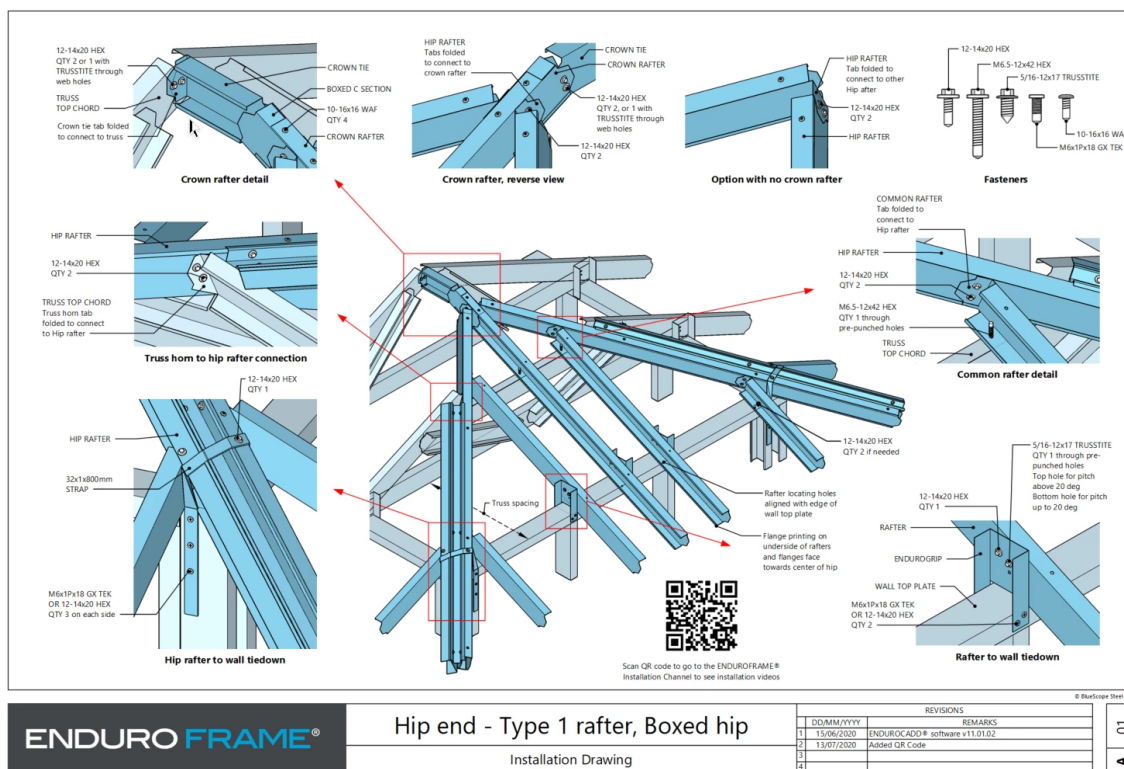


Figure 7.6 Type 1 Hip End Construction with Boxed Hip

Standard ENDUROTRUSS® Framing System hip end trusses (Type 1 Hips) are generally placed perpendicular to the main roof trusses and at the same spacing as the main roof trusses.

### Constructing Type 1 hip roofs

To construct a Type 1 hip roof:

**Step 1:** Study the entire set of architectural and fabrication drawings.

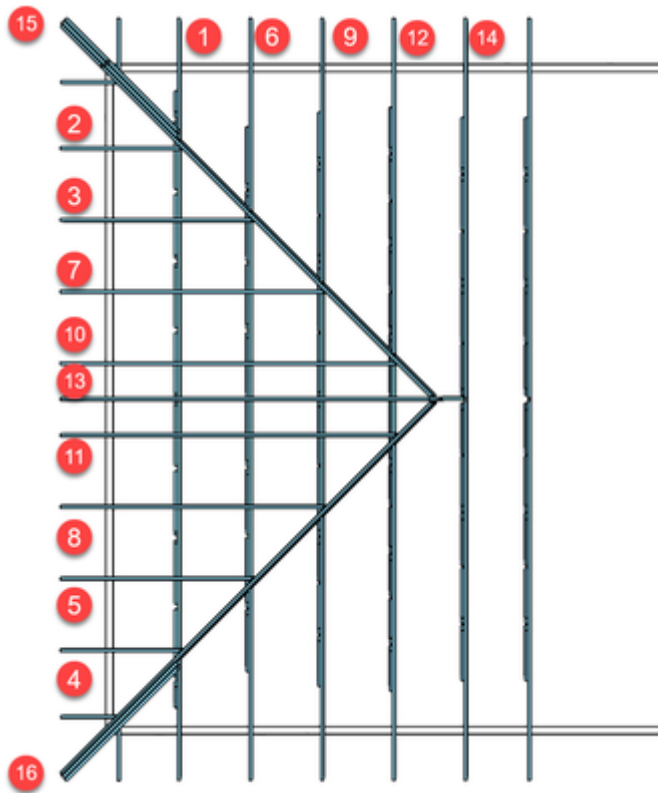
**Step 2:** Set out and mark truss positions as per **Section 7.2.**

**Step 3:** Install fixing brackets to trusses and common rafters with a single screw so they can still be rotated. Hip rafters should be pre-assembled, however assemble if they are not.

**Step 4:** Lift trusses into position, ensuring the webs of the trusses face the hip end wall.

**Step 5:** Stand the first station truncated truss in its set-out position and, fix two #12-14x20mm hex head self-drilling screws through the fixing bracket at each heel connection into the truss chord. If erection screw positions clash with truss manufacture fasteners remove these screws and replace with the erection screws through the bracket and into the chords in the same location.

**Step 6:** Install trusses, common rafters and hip rafters in the sequence shown in **Figure 7.7**. Refer to sections below for fixing details for common rafters, hip rafters, and creeper rafters.



**Figure 7.7: Sequence to install trusses, common rafters and hip rafters on type 1 and type 1A hip end roof**

**Note**

**Note:** Common rafters align with the top chords of the truncated trusses via dimple holes that are punched in both the rafters and truncated trusses.

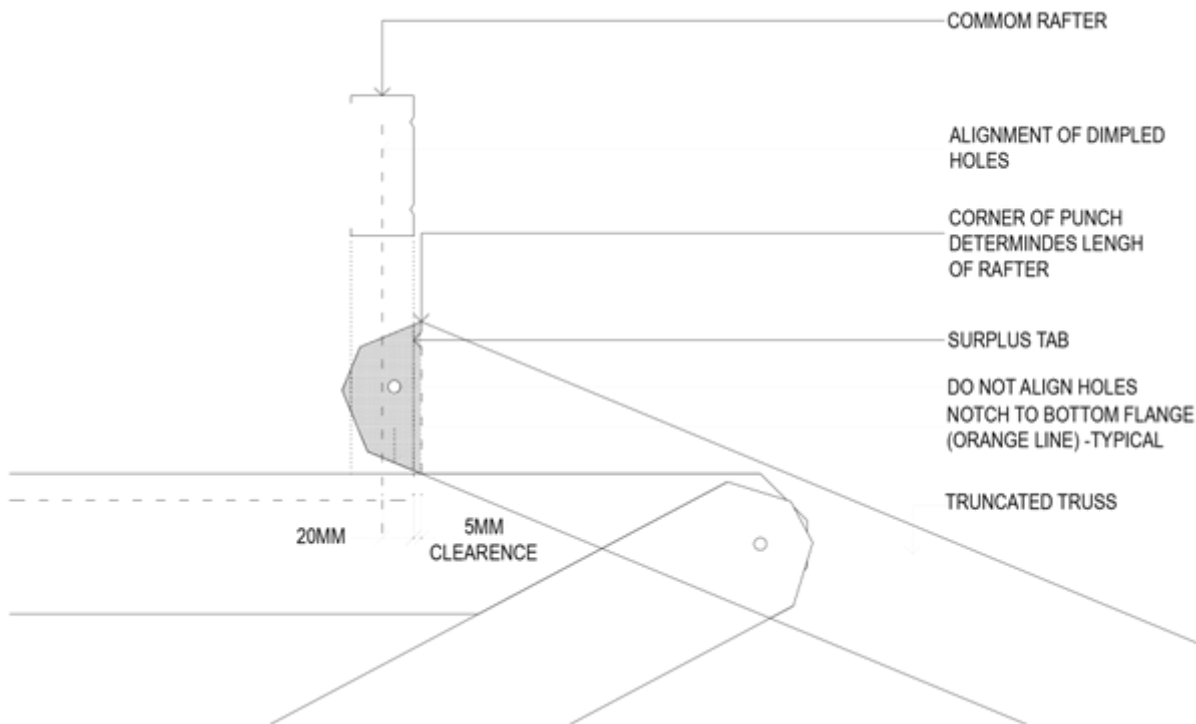
**Note**

**Note:** When all trusses are erected, install wind bracing as specified in **Section 7.9** Roof Bracing.

#### 7.4.2 Connecting Common Rafters in Type 1 Hip End

Common Rafters run perpendicular to trusses to the eave of the building. Toes shall face towards the centre of the roof as shown in **Figure 7.8**. There are a variety of tie down options connecting common rafters both to truncated truss top chords and walls.

The method for connecting common rafters in Type 1 Hip ends to horizontal top chords of truncated trusses and walls is replicated with Type 1A and Type 2 Hip ends.



**Figure 7.8: Common rafter to truncated truss at hip**

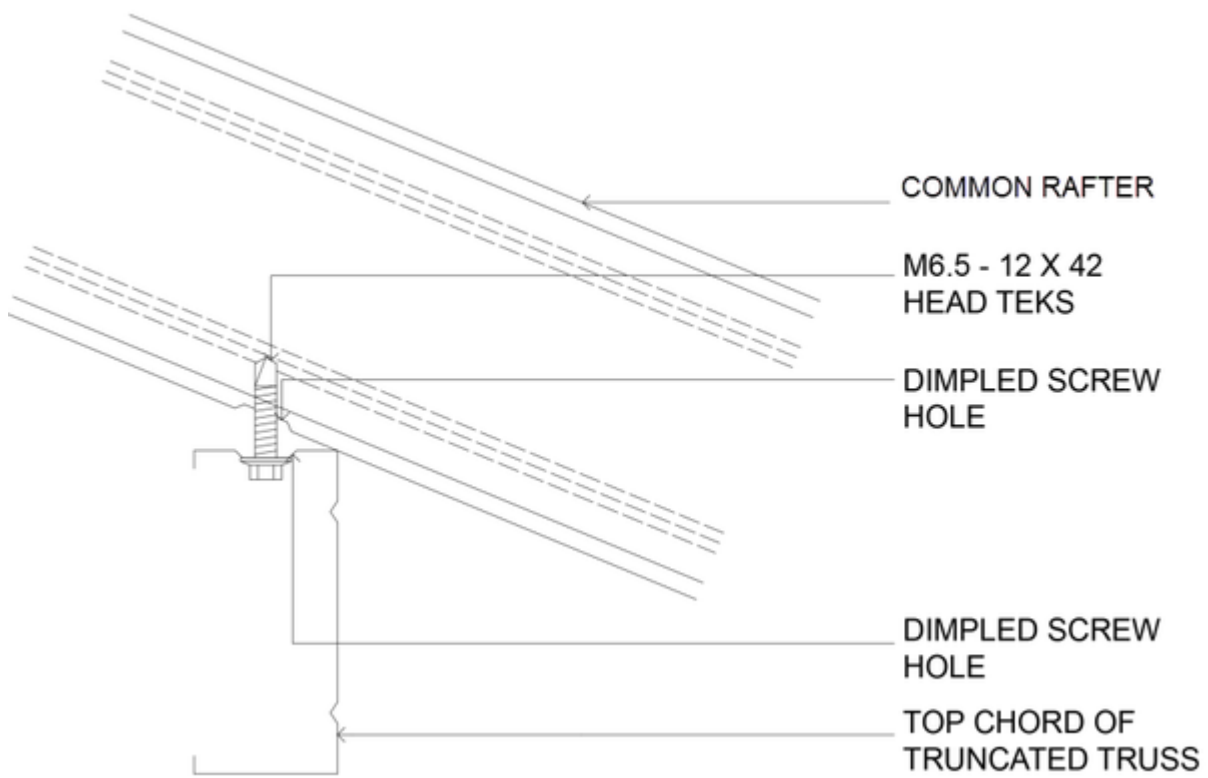


Figure 7.9: Common rafter to truncated truss

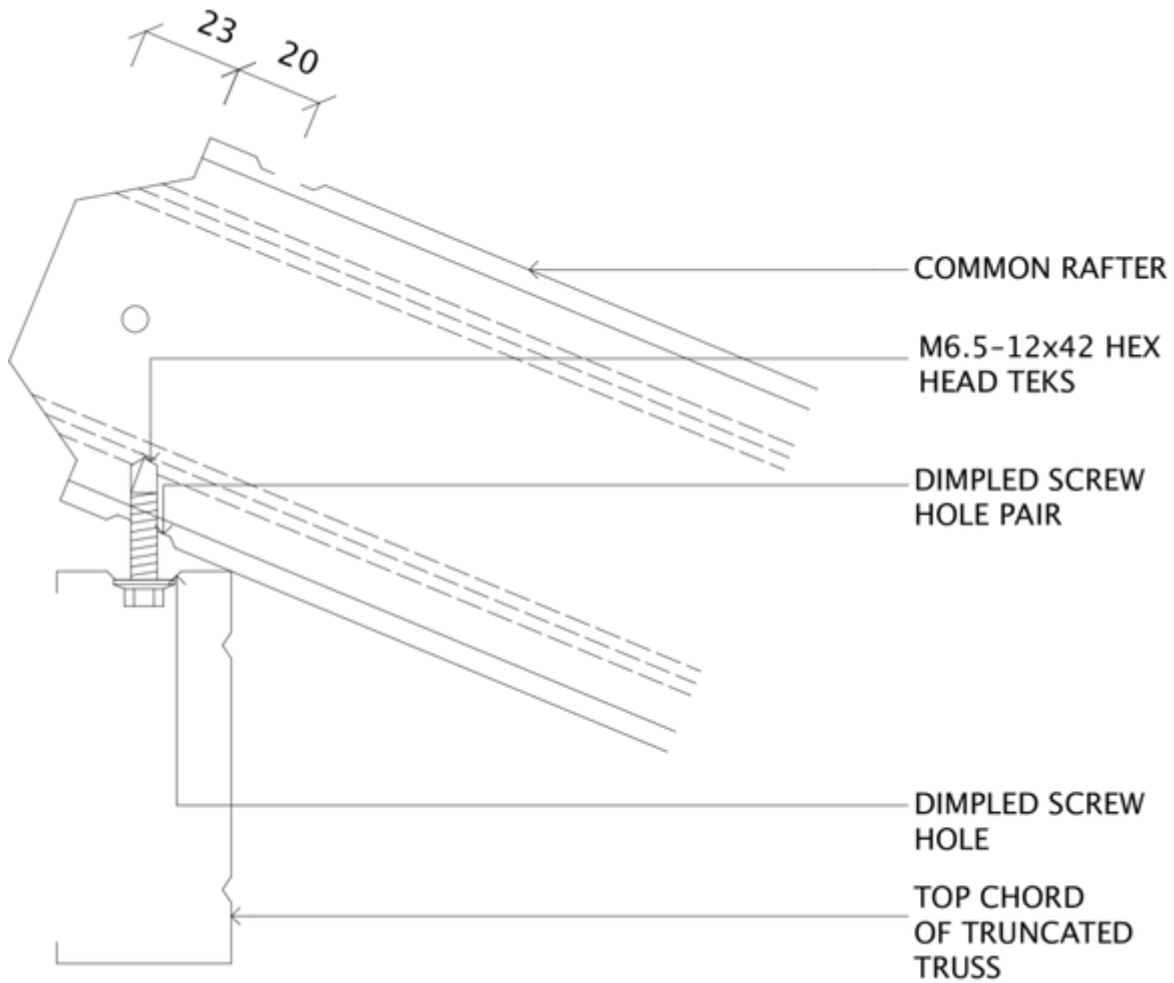


Figure 7.10: Common rafter to truncated top chord end

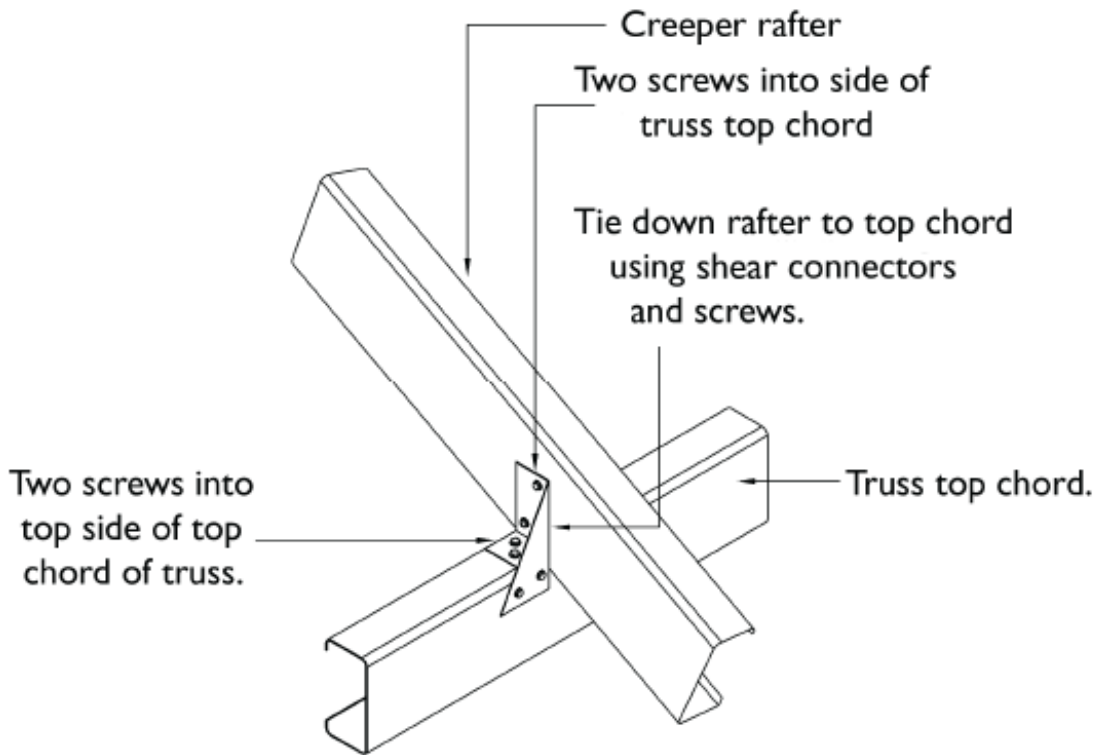


Figure 7.11: Common Rafter to truss top chord using tiedown brackets. Triple grip brackets shown but Multigrip or angle may also be used

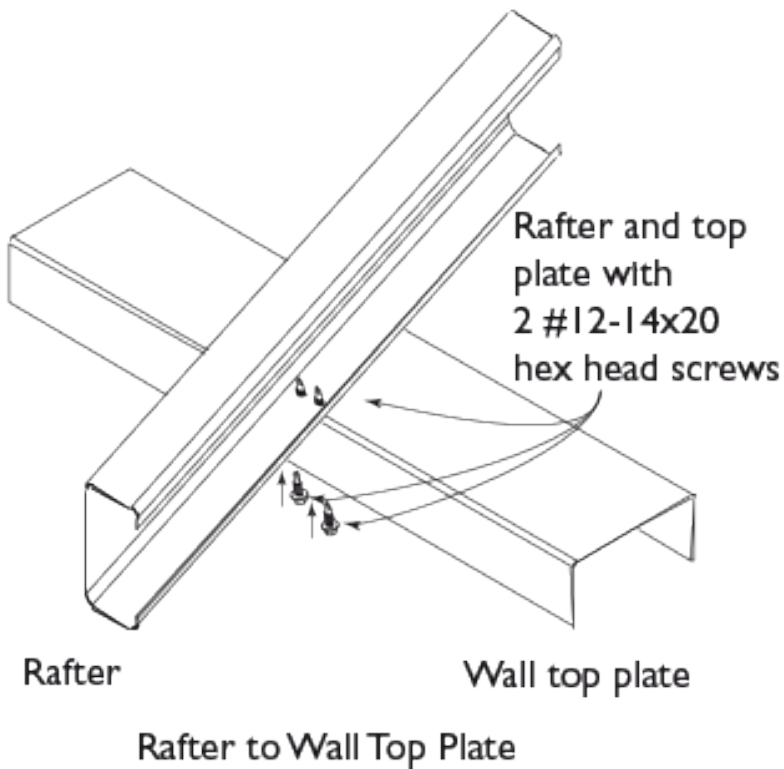


Figure 7.12: Common Rafter/creeper rafter to wall top plate using screws

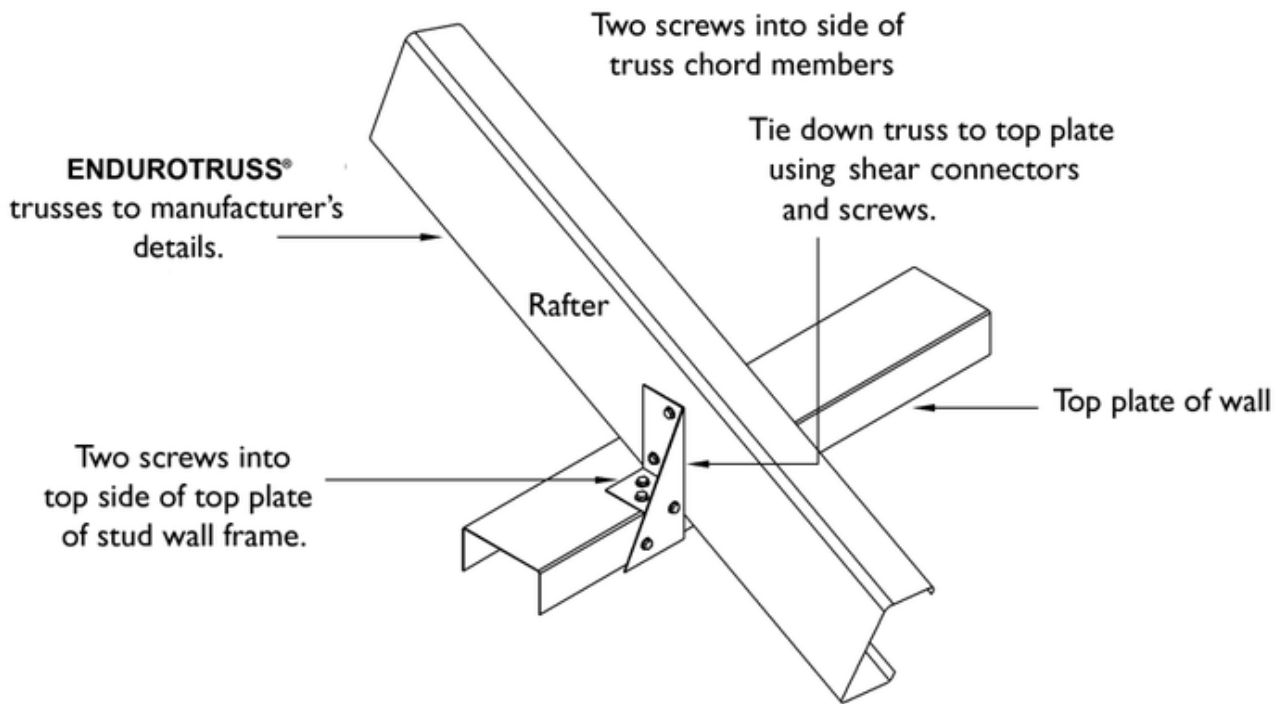


Figure 7.13: Rafter to wall top plate using Pryda® Triple-Grip shear connector

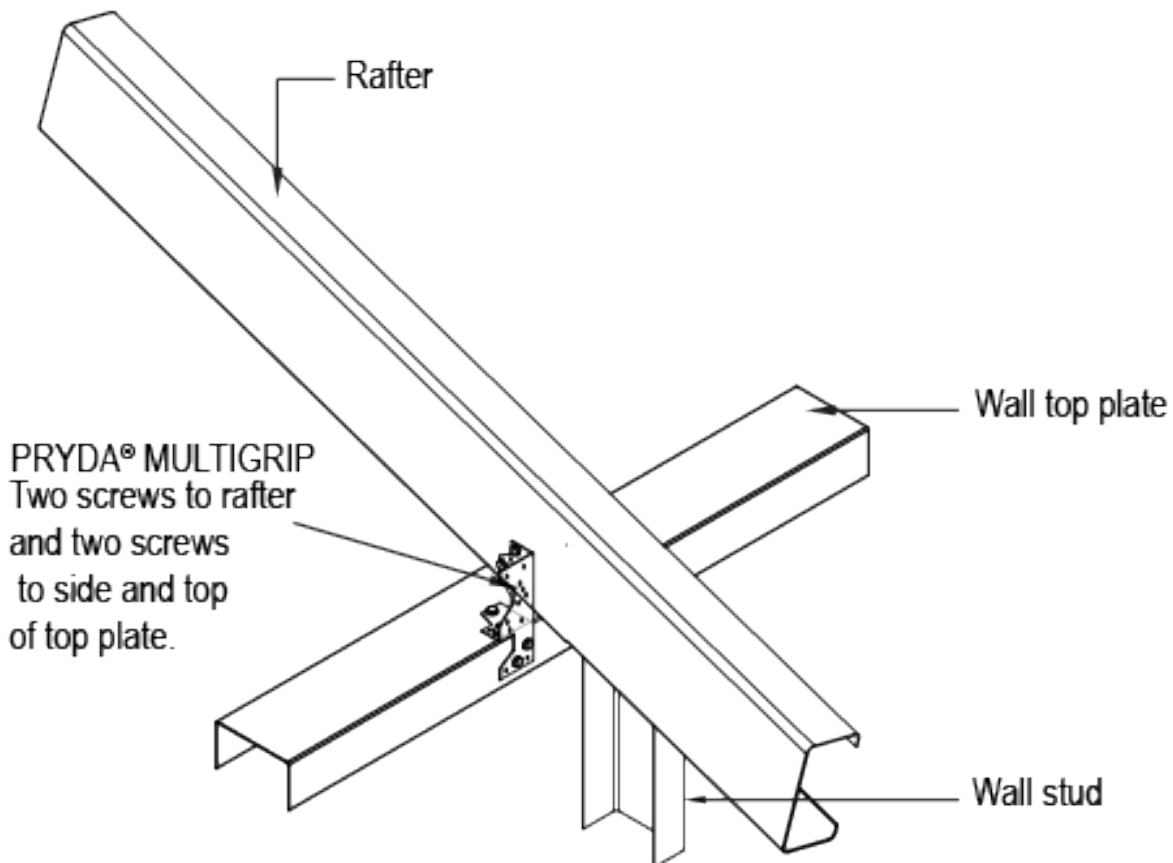


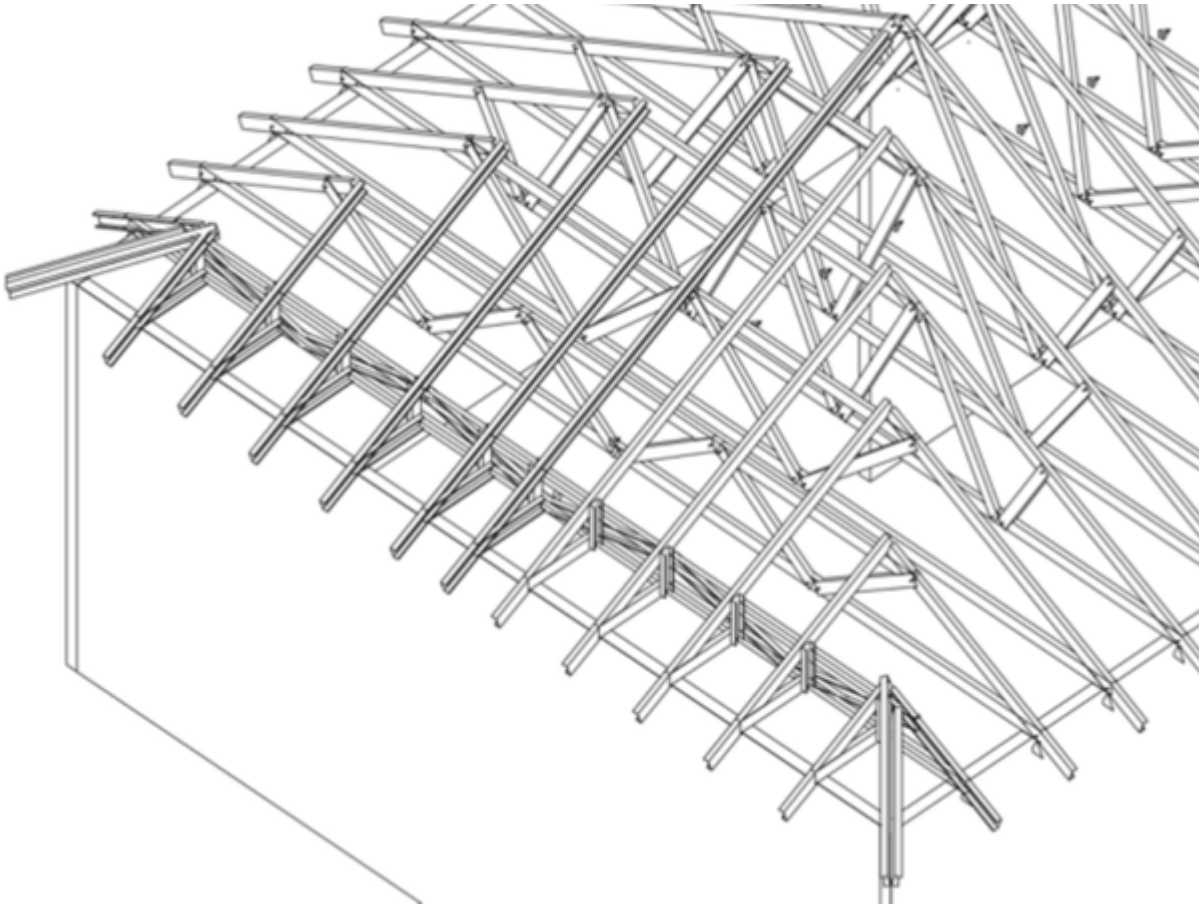
Figure 7.14: Rafter to wall top plate using Pryda® Multi-Grip

#### 7.4.3 Type 1A Hip construction

Type 1A is a variation on the Type 1 Hip. The truss layout and design is identical to the Type 1 Hip. However the rafters are triangulated between the first station truss and the hip end wall by the addition of a horizontal and vertical member.



Each rafter is thus a simple truss with an extended top chord as shown in **Figure 7.15**, creating a hybrid of a Type 1 and Type 2 hip. The purpose of these members is to plumb the first station truncated truss, simplify erection and enable simple installation of rafters where the pitching line is outside the support wall.



**Figure 7.15: Type 1A hip construction**



**Figure 7.16: Installation of a Type 1A hip truss**

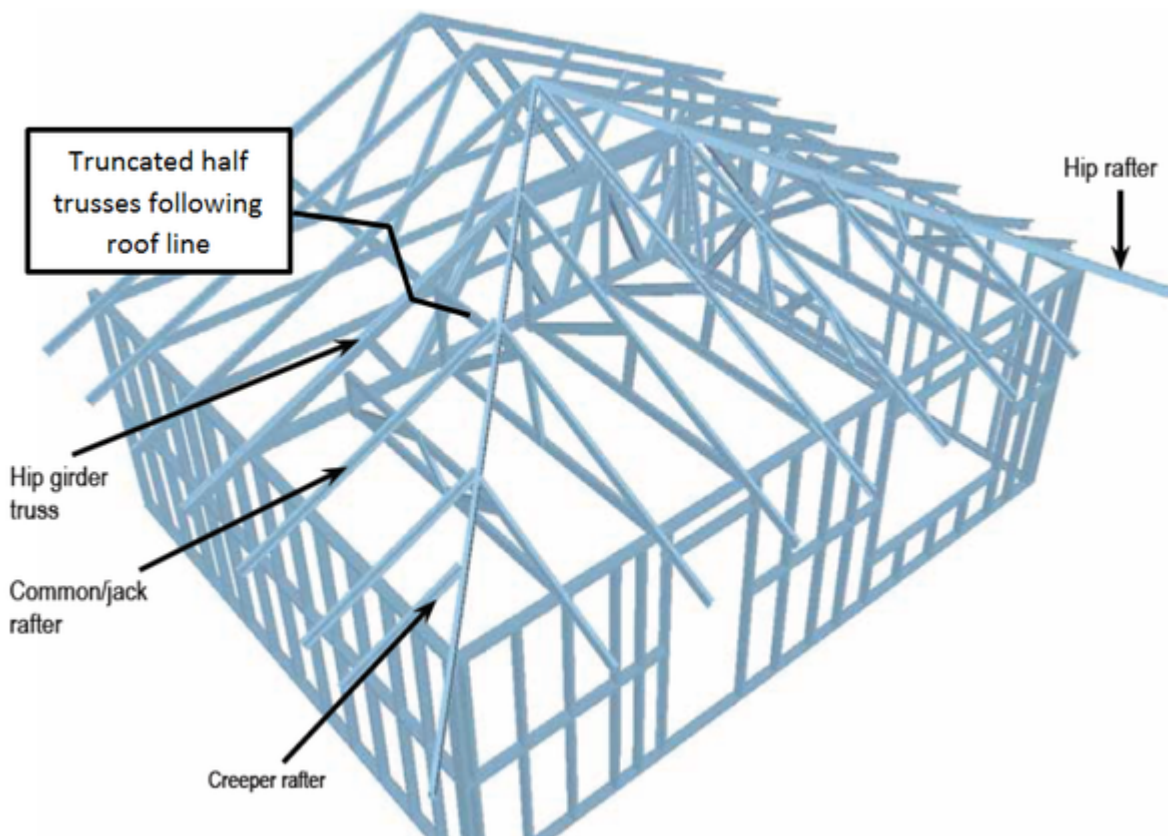
Connection of Type 1A hip ends to walls and truncated truss top chords is the same as the Type 1 Hip End



#### 7.4.4 Type 2 Hip Construction

Type 2 Hips use half trusses supported by a girder truss instead of rafters. These half trusses **must be flush** and are placed in exactly the same location as common rafters, generally with chord toes facing towards the hip centre.

Type 2 Hip ends may also require truncated half trusses to run down the roof line. In this event the same rules apply for setting Horn IP, Hip IP and Rafter IPs on the horizontal top chord of the truncated half trusses as shown in **Figure 7.17**.



**Figure 7.17:**  
**Type 2 hip construction**

#### Constructing a Type 2 Hip roof

To construct a Type 2 Hip roof:

**Step 1:** Study the entire set of architectural and fabrication drawings.

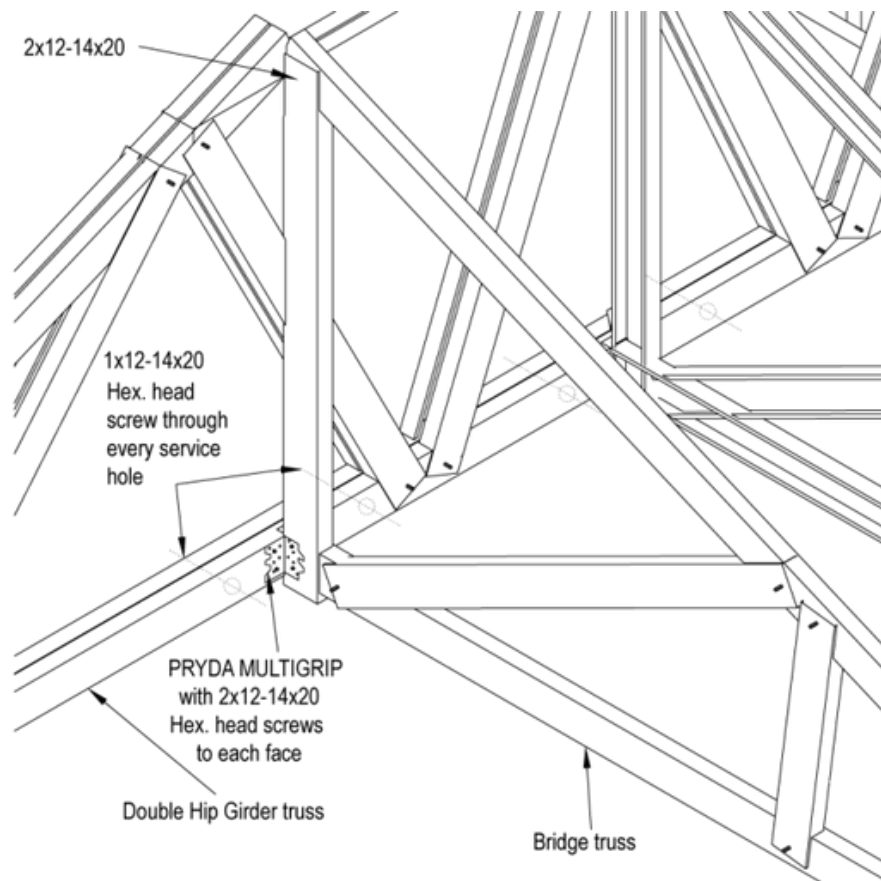
**Step 2:** Set out and mark truss position as per **Section 7.2**. Mark Bridge Truss positions on the Hip Girder Truss bottom chord. If the hip girder is a double truss, ensure that the bridge truss location is marked on the correct truss as specified in the girder truss fabrication sheet.

**Step 3:** Install fixing brackets to the wall top plates to fix girders, bridge trusses and rafters in marked positions.

**Step 4:** Lift girder trusses into position. Note the bottom chord of the Girder trusses is always boxed and that the flat face of the girder faces the hip end wall. If the hip girder is a double truss, install the first ply of the girder truss that is closest to the hip end wall.

**Step 5:** Stand the hip girder trusses in its set-out position and fix two #12-14x20mm hex head self drilling screws through the fixing bracket at each heel connection into the truss chord. If erection screw connection clash with truss manufacturer fasteners, remove these screws and replace with the erection screws through the bracket and into the chords in the same location.

**Step 6:** Temporarily brace the trusses and ensure that they are plumb and straight. This can be done using batten or roof bracing material fixed to the end wall and to the Horizontal top chord of the truss.



**Figure 7.18 Bridge truss to hip girder truss connection**

**Step 7:** Bridge trusses are designed to span between the hip girder and end wall. Position bridge trusses at the locations marked on hip girder truss bottom chord and wall top plate. Install bridge trusses (half trusses) and fix to the external wall top plate using the tie down specified. Refer to **Section 7.8** for tie down options. Fix the bridge truss to the top chord of the girder truss with 2/12-14x20 screws through the web of top chord into the end vertical web of the bridge truss.

Fix the bridge truss to hip girder bottom chord as shown in **Figure 7.18**. Using a Multigrip fixed with 2x12-14x20 hex head screws. The tab on the bottom chord may need to be cut or bent for fixing. Ensure bridge truss spacing is not exceeded.

**Step 8:** A single girder truss can be tied down using either a 25 x 5mm strap tie down or a 50 x 50 x 3mm angle tie down as is shown in **Figures 7.19** or **7.20**. Install the second ply girder truss (if applicable) with the toes of both trusses facing each other and fix it to the brackets as shown in **Figures 7.21** or **7.22**. Install 1x12-14x20 Hex Head screws through **every** service hole provided on the bottom chord to connect the two trusses together as shown in **Figures 7.23**.

**Step 9:** Refer to **Section 7.4.5** for hip rafter installation. In case of Veed Rafters, the difference is that the shorter rafter is located on the inside of hip while the longer rafter (supported by the truncated truss) is on the outside of the hip.

**Step 10:** Refer to step 9 of **Section 7.4.2** for common / jack rafter installation.

**Step 11:** Refer to step 10 of **Section 7.4.8** for creeper rafter installation.

**Note:** When all trusses are erected, install wind bracing as specified in **Section 7.9** on Roof Bracing.

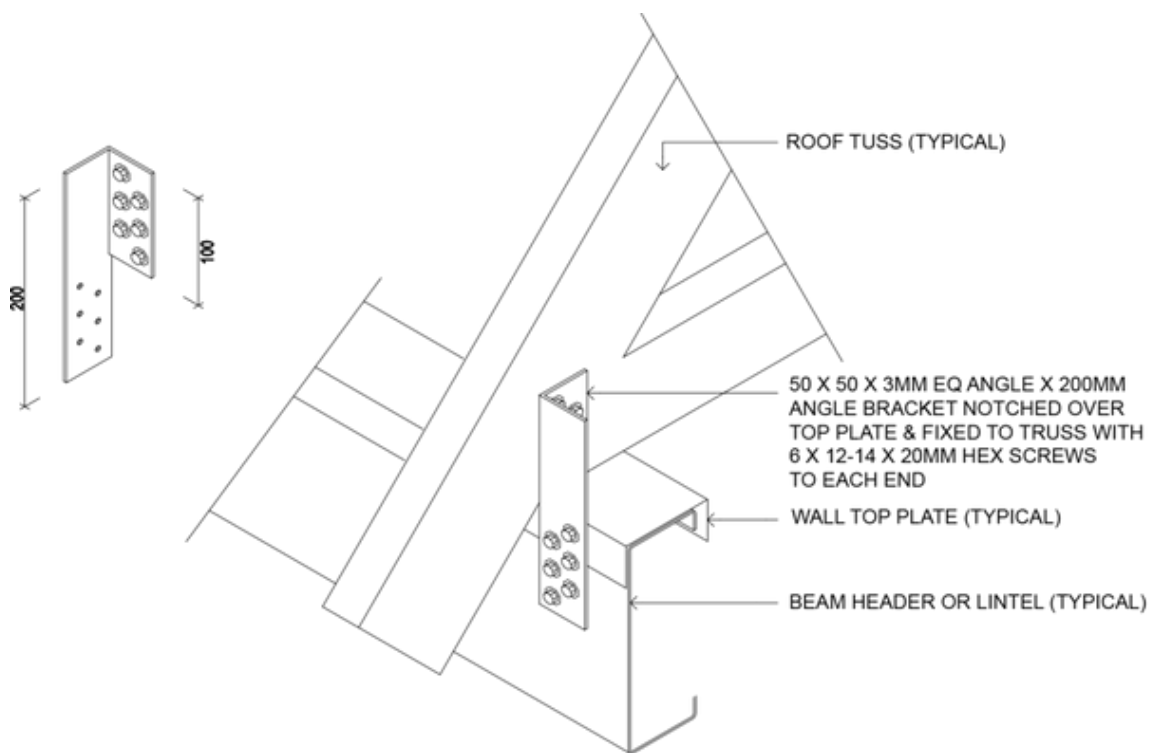


Figure 7.19 Single girder truss to wall top plate connection using angle tie downs

Fig

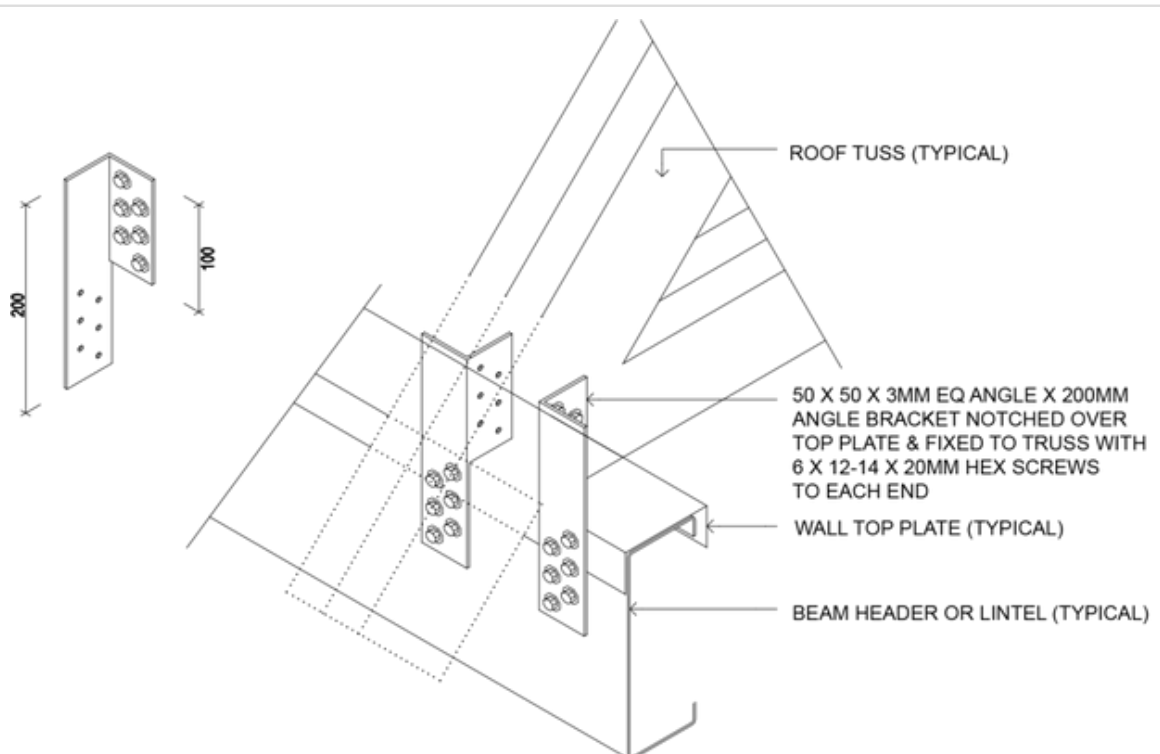


Figure 7.21 Girder truss to wall top plate connection using angle brackets

Fig

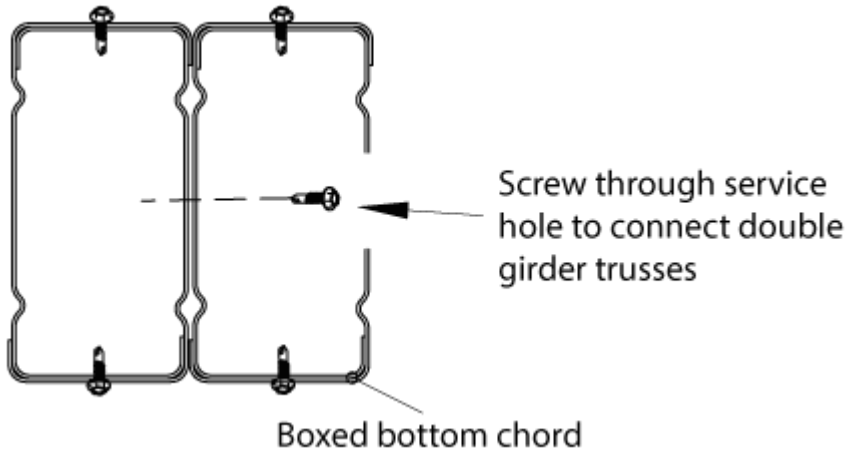


Figure 7.23 Connection between double girder trusses

### 7.4.5 Hip Rafter Construction

There are three hip rafter types that can be used with any type of hip end construction:

- boxed hip rafter
- veed hip rafter
- hip truss rafter.

#### 7.4.5.1 Boxed Hip Rafters

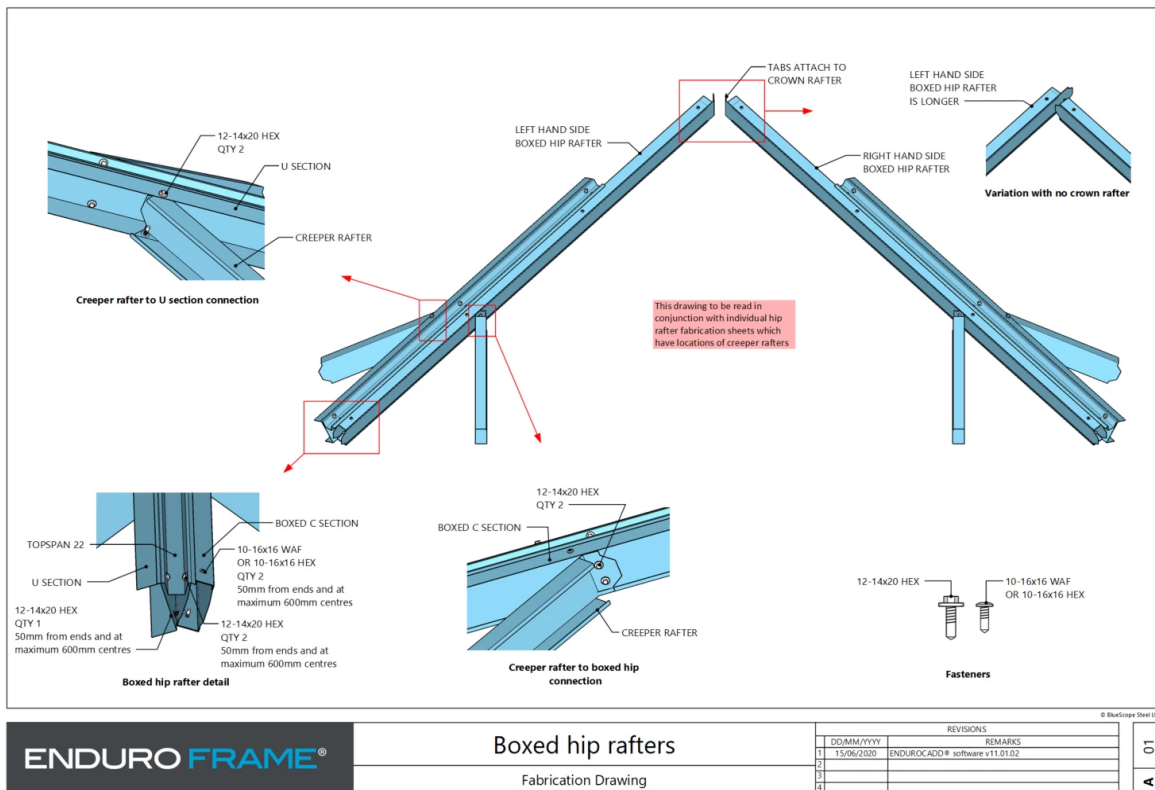


Figure 7.24 - Boxed Hip Rafter Fabrication

Boxed hip rafters are made from two boxed sections of the same section used for the common rafters, with U sections connected to the boxed hip rafters with a Topspan 22 ceiling batten. Creeper rafters are attached to the side of the boxed hip to provide a fixing point for fascia board. Fabrication sheets are prepared for each boxed hip rafter pair which includes the locations for the creeper rafters to be attached. An example of the fabrication sheet is shown in **Figure 7.25**. There is a left and right boxed hip rafter option. The left and right hip rafter is identified by looking at the hip end from outside the end of the roof.

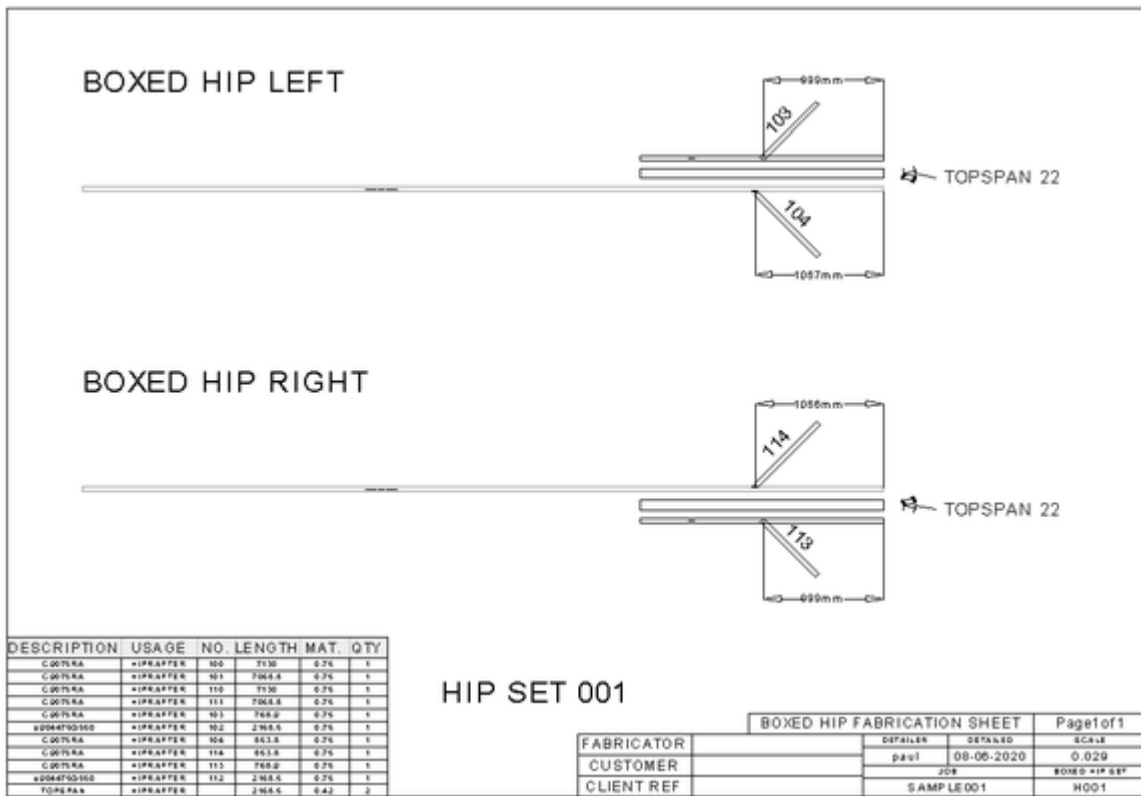


Figure 7.25 - Boxed Hip Rafter Fabrication Sheet

Boxed hip rafters extend along the entire hip line of the roof from the eave line to the apex of the roof. Figure 7.6 includes all of the details to install a boxed hip rafter to a steel wall frame.

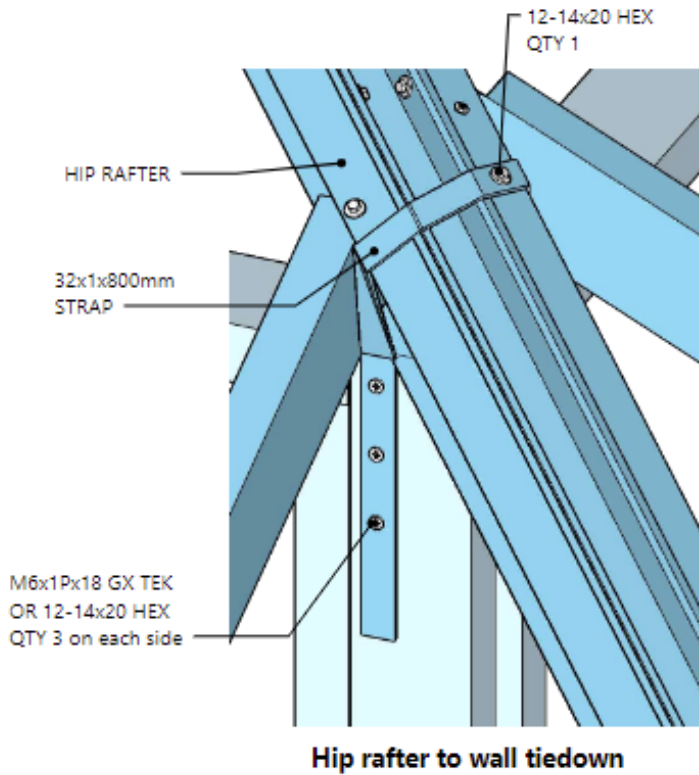
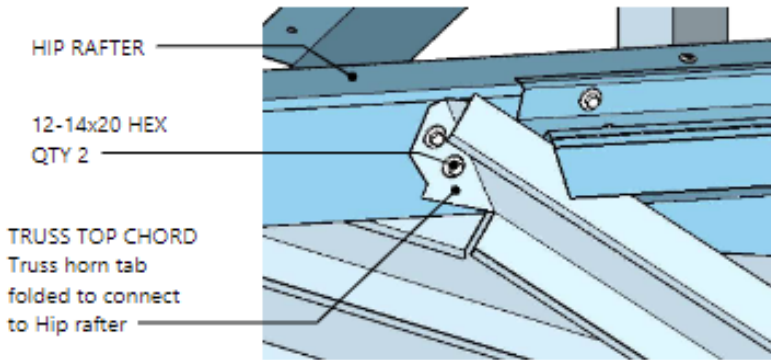


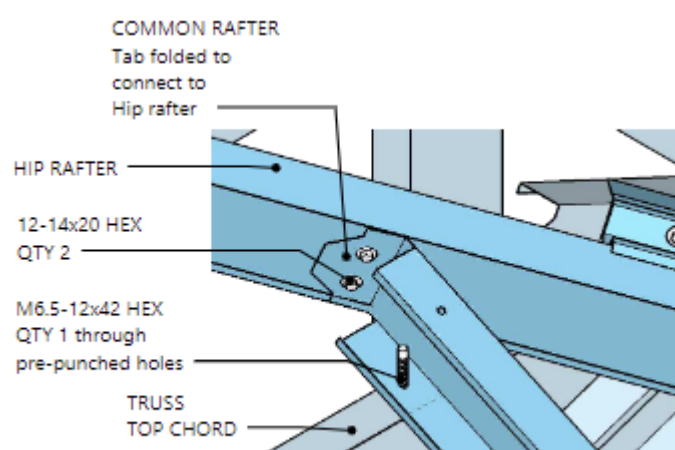
Figure 7.26: Boxed Hip rafter to wall tiedown detail

The recommended method to tie down a boxed hip rafter is with a 32 x 1mm strap which wraps over the boxed hip rafter and is connected to studs on the supporting walls. A single 12-14x20 hex head fastener is placed in the top of the boxed hip to prevent the hip rafter from rotating, and 3 pieces of 12-14x20 hex head fasteners on each end of the strap bracing to tied the boxed hip rafter to the 2 studs. If walls other than steel walls are used, alternative connection methods should be used.



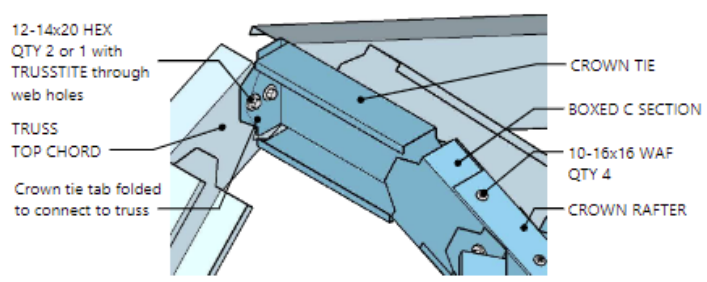
**Truss horn to hip rafter connection**

**Figure 7.27: Boxed hip rafter to horn connection**

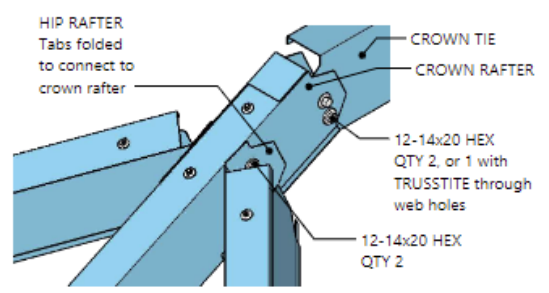


**Common rafter detail**

**Figure 7.28: Connecting Common Rafters to Boxed hip rafter**



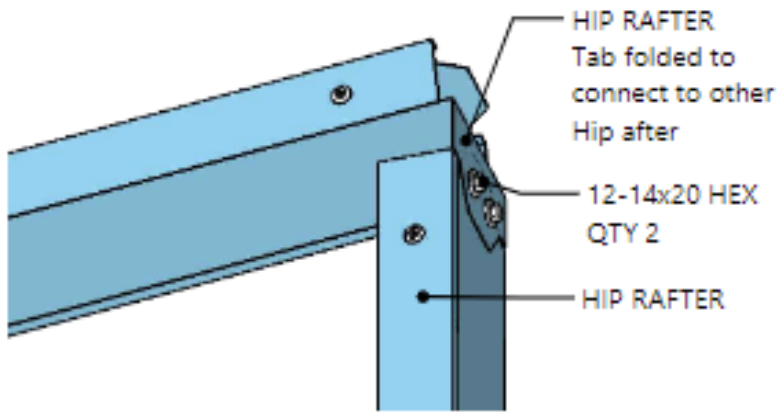
**Crown rafter detail**



**Crown rafter, reverse view**

**Figure 7.29: Crown end rafter to boxed hip rafter**





### Option with no crown rafter

Figure 7.30: Connecting Boxed hip rafter at apex with no crown rafter

#### 7.4.5.2 Veed Hip Rafters



Figure 7.31: Veed hip rafters sitting on walls

Veed hip rafters are standard components that run from the second truncated truss to the edge of the roof. Veed hip rafters:

- require the least amount of material, although there is some time required for assembly
- sit on the corner of external walls and are not suitable when the pitching point extends beyond the external walls.

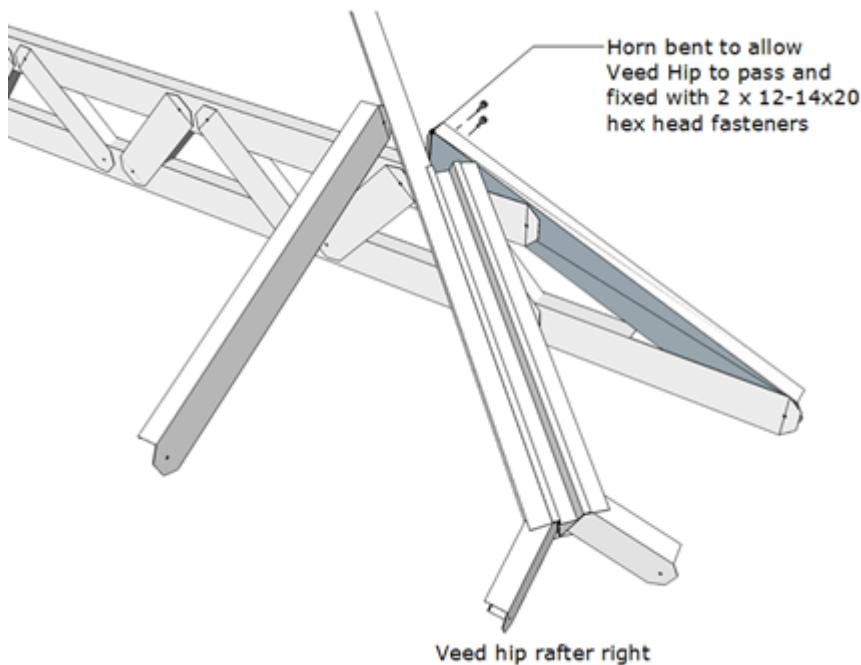
They are available in various standard lengths and as left and right sections (**Figure 7.32**) to facilitate nesting against the horns of truncated trusses.





**Figure 7.32: Left and right veed hip sections**

The position of the Veed hip rafter relative to the truss horn and common rafter is shown in **Figure 7.33**. The Veed plate hip rafter is manually adjusted along the hip line until it is in the correct position and the eave is correct. The creepers may be adjusted by folding in and out until they are in the correct location, and then fixed in place with a second fastener.



**Figure 7.33: Installation of Veed hip rafter relative to horn and common rafter**

Creeper rafters, if required, are pre-attached to the Veed plate hip rafter and support the fascia. There is a left and a right side with the longer rafter aligned with the bent notch on the horn of the truncated truss as shown in **Figure 7.33**.

The Veed hip rafters are kept at a V section by running a Topspan 22 batten between the two chords, and the creeper rafters are pre-attached to the assembly.



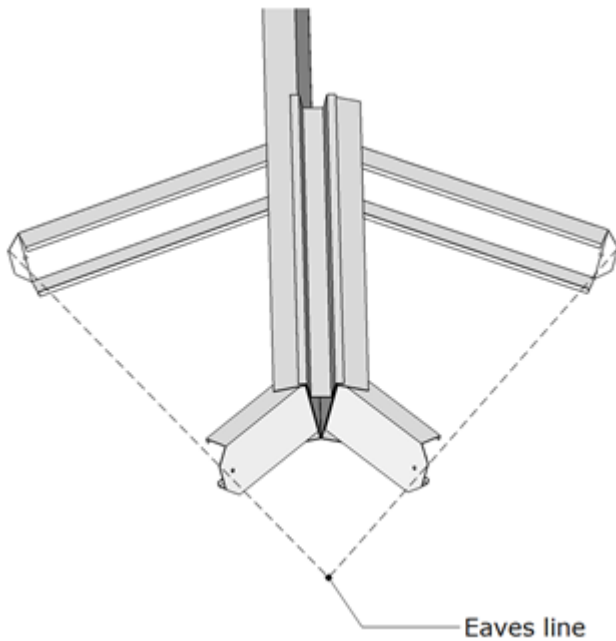
**Figure 7.34: Installed veed hip rafter with creeper rafters bent out**

The type of veed hip rafter components and the length of each of the components depends on the size of the overhang following the table below.

Overhang (mm)	Veed hip part no.	Section used	Dimensions (mm)			
			A	B	C	Trim
0 – 200	VH75-200L	C7575ra	2060	680	410	480
	VH75-200R					
	VH90-200L	C9075ra				
	VH90-200R					

200 – 500	VH75-500L	C7575ra	2725	905	700	720
	VH75-500R					
	VH90-500L	C9075ra	2725	905	700	720
	VH90-500R					
500 – 700	VH75-700L	C7575ra	2725	1320	905	1120
	VH75-700R					
	VH90-700L	C9075ra	2725	1320	905	1120
	VH90-700R					
700 – 900	VH75-900L	C7510ra	3000	1680	1080	1480
	VH75-900R					
	VH90-900L	C9010ra	3000	1680	1080	1480
	VH90-900R					

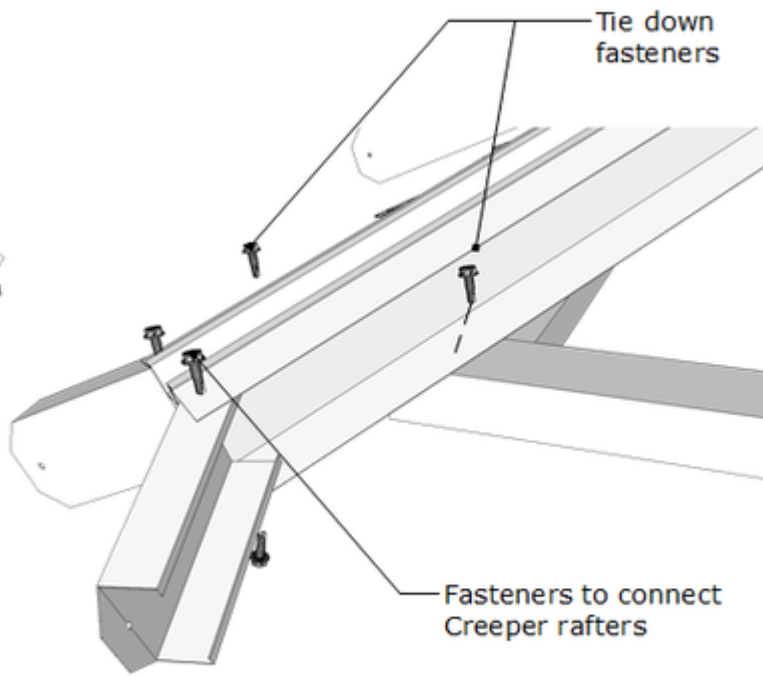
The bottom flange of the longer veed hip plate section needs to be manually trimmed on site in order to fit into the truncated truss and not be obstructed by the horn on the truncated truss.



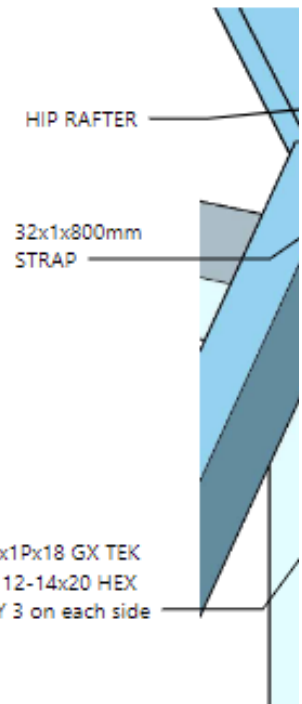
**Figure 7.35: Veed Hip rafter relative to eaves line**

In wind regions N1 – N3 and with overhangs of less than 200mm Veed hip rafters are fixed to the top plate using 2 x 12-14x20 hex head fasteners fastened through to the top plate as shown in **Figure 7.36**. In all other wind areas Veed hip rafters are tied down to truncated trusses and to wall frames using 32 x 1mm strap fixed with 3 x fasteners at each of the strap as shown in **Figure 7.37**.





Fixing Veed hip rafter to top plate



M6x1Px18 GX TEK  
OR 12-14x20 HEX  
QTY 3 on each side

Figure 7.36: Fixing Veed hip rafter to top plate in low uplift locations

Figure 7.37. Tying down Veed hip ra

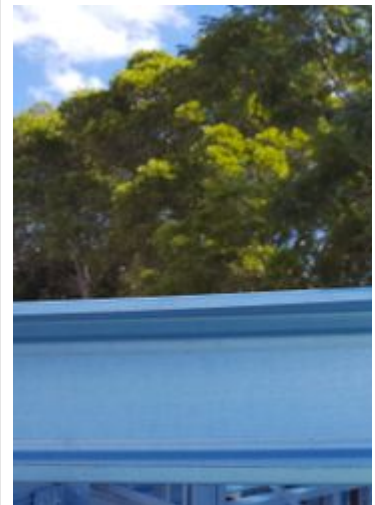


Figure 7.38 Veed hip rafter connecting to first station truncated truss (note: bottom flange of veed hip plate notched)



Figure 7.39 Fixing Veed Hip rafter to top plate

### 7.4.5.3 Hip Truss

Hip trusses are flush trusses that run along the hip line from the eave to the first truncated truss for Type 1 and Type 1A hip ends, and to the truncated truss for a Type 2 Hip End. Hip trusses are the only option when the pitching point is extended past the external walls. Hip trusses are made from the same sections as the default selections made for the roof trusses.

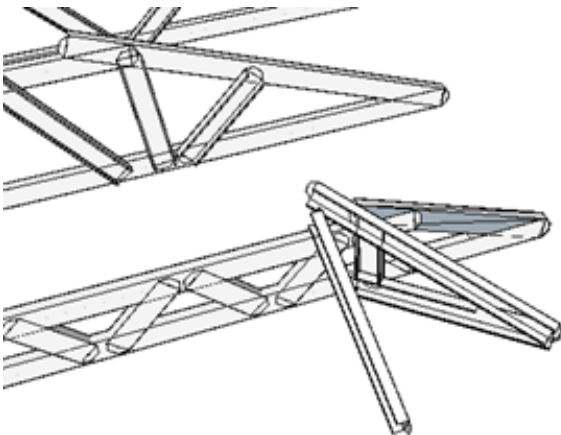
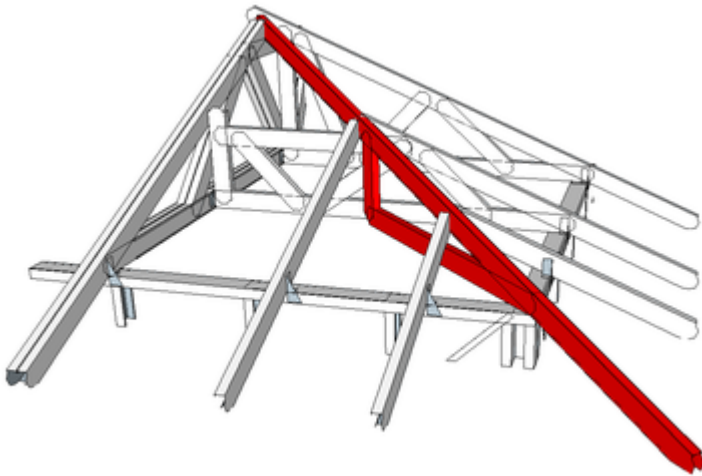


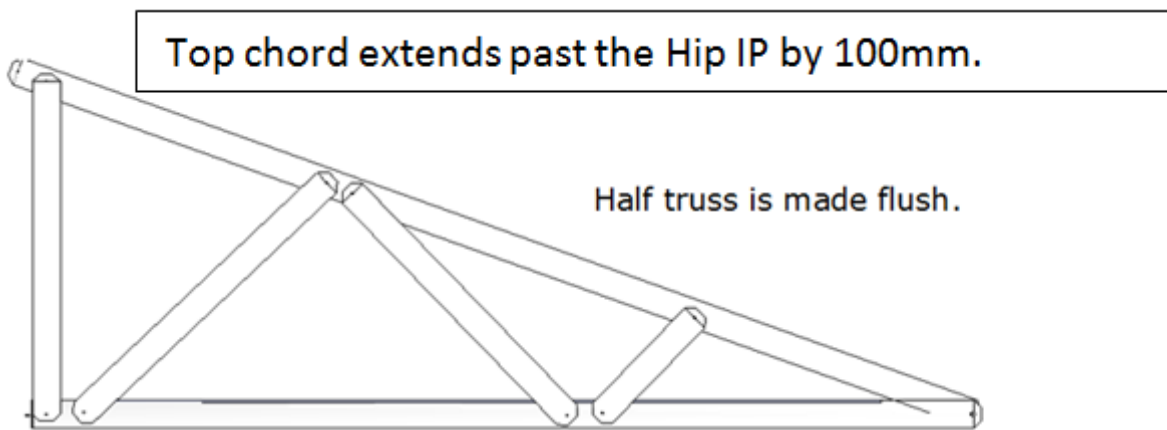
Figure 7.40: Hip truss on a Type 1 or Type 1A Hip End



**Figure 7.41: Hip truss on Type 2 Hip End**

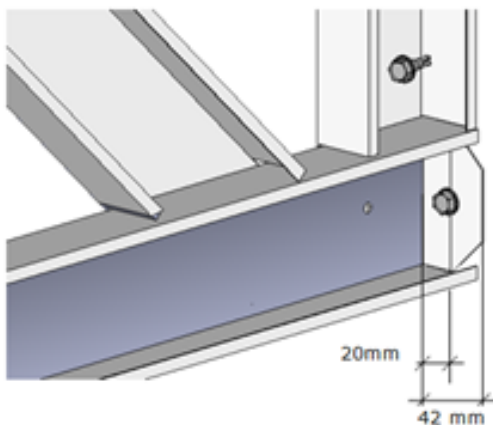
For a Type 2 Hip end the vertical chord on the hip truss stops at the first truncated truss, however it extends up to the girder truss. The creeper rafters are attached to the face of the of the hip truss.

The half trusses are all flush truss to allow for easy fixing onto the first truncated truss, and are identical to the primary half trusses used in a radial roof. The top chord extends past the vertical member by 100mm as defined in **Figure 7.37**.



**Figure 7.42: Hip truss**

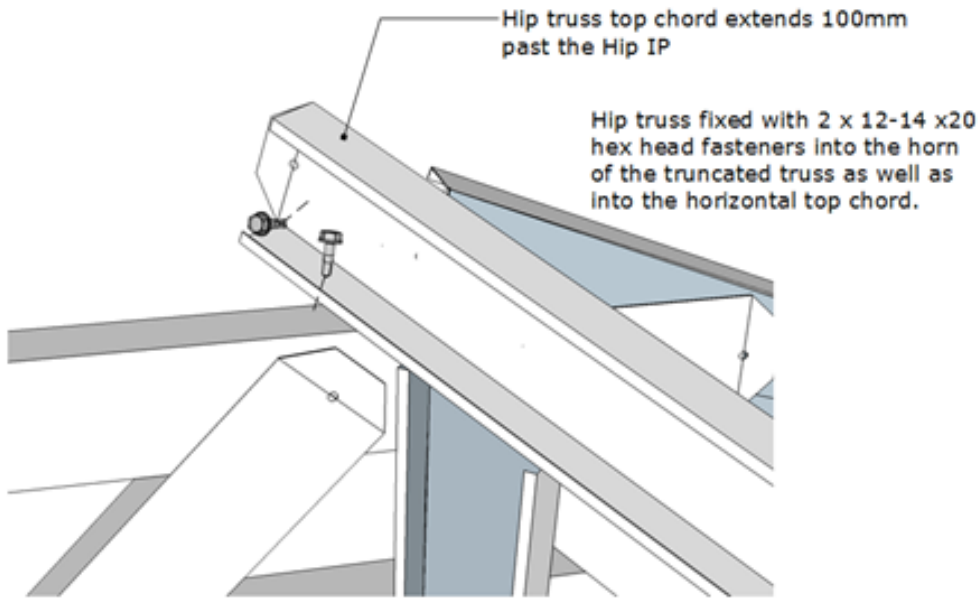
The bottom chord has a tab extending 40mm past the vertical chord. Both the top and bottom flanges are notched to allow this to happen. This is manually bent 45 degrees as demonstrated in **Figure 7.38**. The half truss is fixed with 2 x 12-14x20 hex head fasteners through both the top chord and the bottom chord into the truncated truss.



The 6mm hole at the end of the bottom chord is 20mm past the outside face of the vertical chord. This means the bottom chord extends past the vertical chord by 42mm. The top and bottom flange of the bottom chord is notched from the face of the vertical chord.

**Figure 7.43: Connection between Hip truss and bottom chord of truncated truss**

The top chord of the hip truss extends past the hip IP by 100mm. The horn on the truncated truss is bent 45 degrees for the hip rafter to fix to. The toes on the hip truss face towards the center of roof. Details are shown in **Figure 7.39**.



Toes on the hip truss face towards the center of the roof.  
(Note: rafter not shown for clarity)

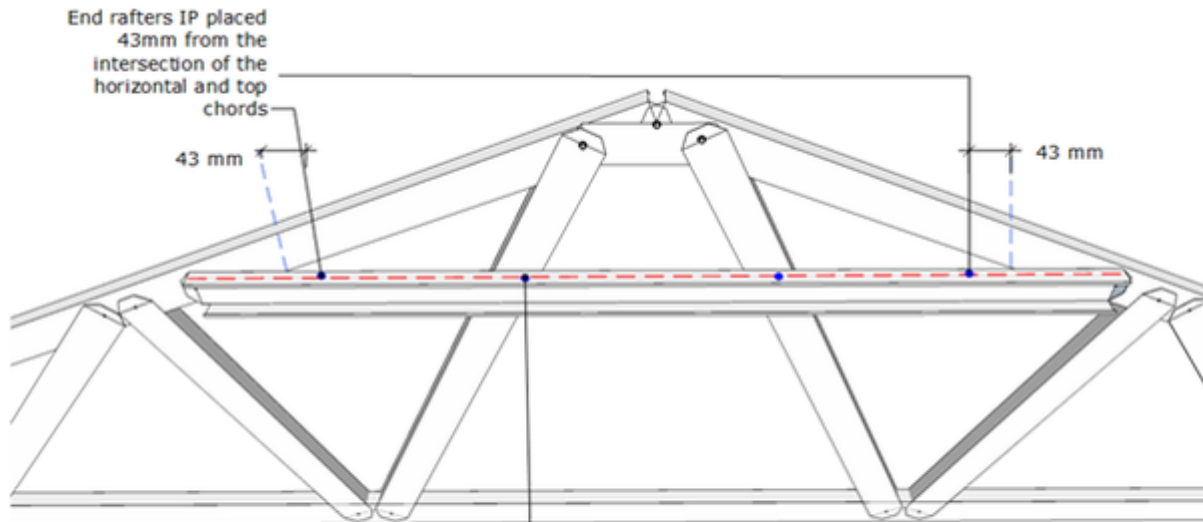
**Figure 7.44: Top chord of hip truss**

Tie down connections for trussed hips shall be the same as normal trusses. A 25 x 1mm overstrap can be selected and used similar to a Veed hip rafter as shown in **Figure 7.32**.

**7.4.6 Common Rafter on**

**Dutch Gables**

Common rafters connect to a flush truss with the toes facing away from the hip end, and a horizontal rail back-to-back with the truss chords and webs. End rafter IPs are placed 43mm away from the intersection point of the underside of the top chord and the horizontal rail towards the center of the truss. Additional intermediate rafter IPs are placed along the horizontal rail at no more than the truss spacing at even spacings. This is demonstrated in **Figure 7.49**.



Dutch gable truss is a flush truss with toes facing away from the hip end. A horizontal rail is placed at the rafter line.

Intermediate rafter IPs evenly spaced between the end rafters IP at no more than the truss spacings.

**Figure 7.45: Location of rafter**

**IPs on a Dutch Gable truss rail**

Common rafters fit onto the horizontal rail following the cross section shown in **Figure 7.45**.

If the V notch on the rafter clashes with either the webs or chords it would be manually trimmed or bent on site so it can fit.

**7.4.7 Crown Rafters**

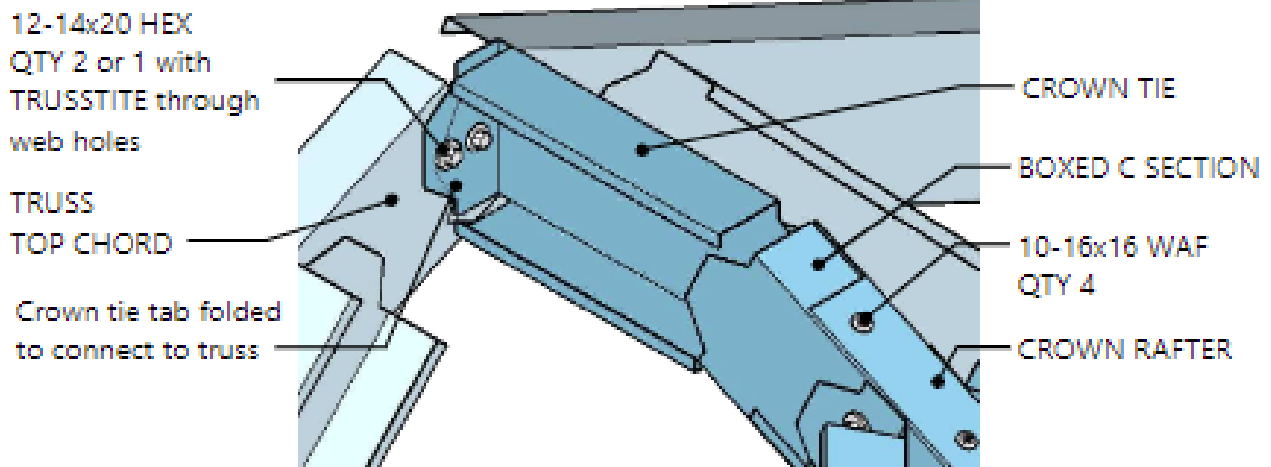


A Crown Rafter is positioned at the centre of a standard hip face running from the intersection point of the hip lines to the outside edge of the eave block.

A Crown Rafter Tie is an additional horizontal piece spanning from the top of the crown rafter (intersecting hip lines) to the first standard truss. The minimum distance from the top of the crown rafter to first standard truss should be 150mm for the horizontal extension piece to be implemented.

The length of this crown rafter tie will be 40mm past the Top Chord of the adjacent standard truss.

The end of the Crown Rafter tie will have flange and lip notches (like the bent tab at bottom of studs). This then gives flexibility on site to be manually bent and a screw manually added through the web of the rafter extension into the top chord of the adjacent truss.



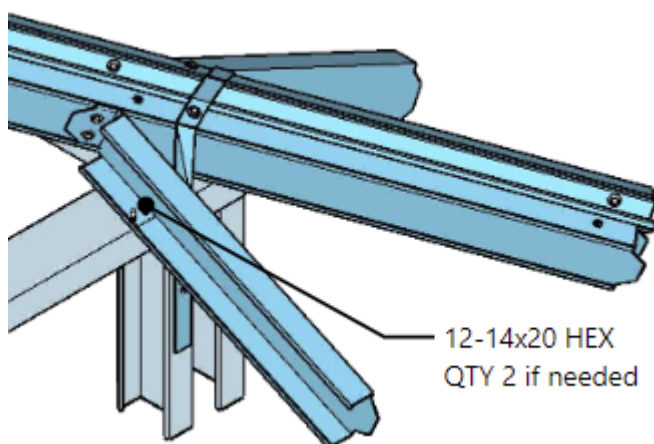
**Crown rafter detail**

**Figure 7.46: Crown Rafter Tie Details**

**7.4.8 Creeper Rafters**

Creeper rafters are required where the spacing between the point between the end of the hip rafter and either the first truncated truss or the common rafter exceeds the maximum truss spacing. They are only required for a Boxed Hip or a Hip Truss, as Veed Hip Rafters have in-built creeper rafters. Connection of creeper rafters is similar to the connection between a secondary and primary truss in a radial roof.

A creeper rafter is positioned to land on the wall at the mid-point between the hip rafter and either the first station truncated truss and/or the first common rafter. In the case of a boxed hip, a single member is added as a top chord while with a hip truss, a truss is added, and is connected at both the top and bottom chord of the hip truss.



**Figure 7.51: Hip/creeper rafter connection**

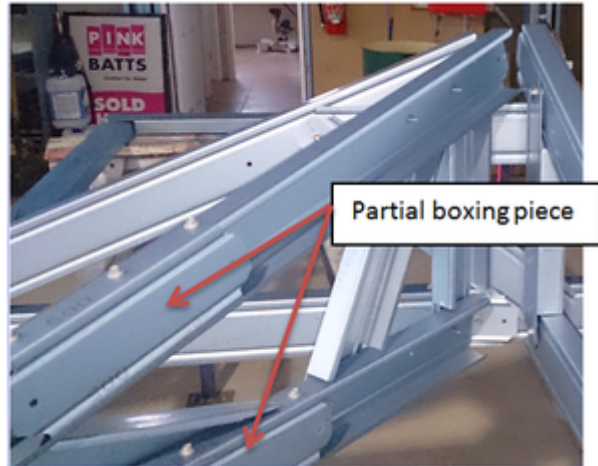
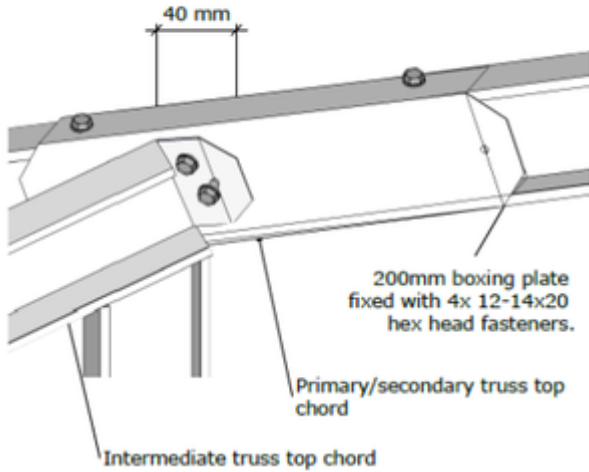
The toes on the creeper truss/rafter face away from the boxed hip/hip truss.

When a hip truss is selected, the creeper rafter has a vertical and horizontal chord similar to a small truss. In this scenario, the top and bottom chord on the creeper rafter extend past the vertical chord on the creeper rafter by 40mm, and are notched on both flanges so

they can be bent at 45 degrees and fixed to the primary truss as shown in **Figures 7.52 and 7.53**. If this tab a damaged a Pryda MT15 Plate can be used.

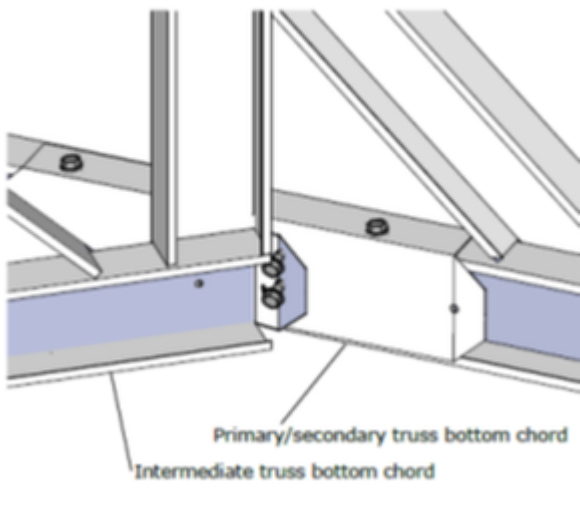
Where the creeper truss connects to the open face of a hip truss a 200mm long boxing piece is attached to the hip truss to provide a fixing point. This 200mm long piece is cut from surplus material and factory or site installed. The centreline of the boxing piece on the top and bottom chords shall be marked on the fabricated drawing.

The end of the intermediate truss top chord extends past the primary truss by 40mm. It is notched on both flanges and is manually bent, and attached with 2 x 12-14x20 hex head fasteners.



**Figure 7.52: Connecting top chord of creeper to hip truss (hip truss shown)**

The end of the intermediate truss bottom chord extends past the primary truss by 40mm. It is notched on both flanges and is manually bent, and attached with 2 x 12-14x20 hex head fasteners.

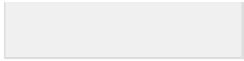


**Figure 7.53: Positioning of bottom chord of creeper rafter onto a hip truss**

Creeper rafters are generally built with just a single top chord however may require a vertical and horizontal chord to be inserted. This is required especially where the truss pitching point is cantilevered past the walls as the horizontal and vertical chord will ensure that the top chord follows the roof plane when the creeper rafter is installed.

The rules for construction of creeper rafters are described in the following table:

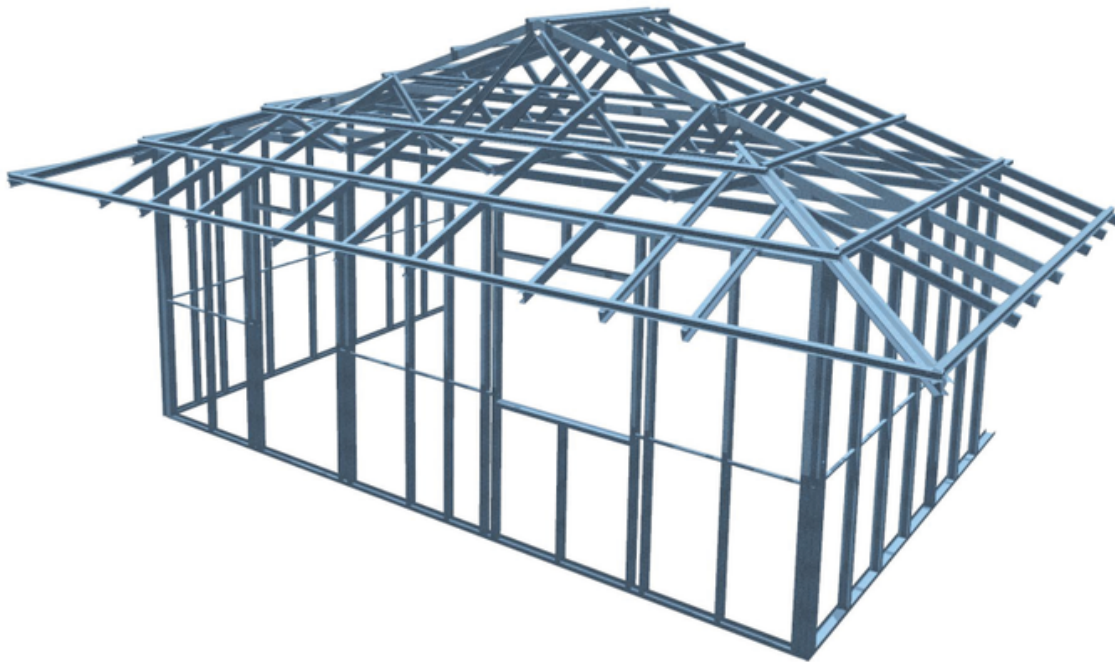
		Hip Rafter selection		
		Veed Plate	Box hip	Hip Truss
Hip end selection	Type 1	Single chord	Single chord	Single chord
	Type 1A	Single chord	Top chord, vertical chord & horizontal chord	Top chord, vertical chord & horizontal chord
	Type 2	Single chord		



Top chord, vertical chord &  
horizontal chord

Top chord, vertical chord &  
horizontal chord

## 7.5 Dutch gable construction



**Figure 7.54: Dutch gable**

Dutch gables are constructed in a similar way to Type 1 hip ends. A standard A truss is provided at the nominated set-back position and is provided with a horizontal channel rail to support the rafters. Installation of truncated trusses and rafters is in accordance with the Type 1 hip end construction. The setback position is shown on the truss layout drawing shown in **Section 7.2**.

### Constructing Dutch Gables

To construct a Dutch Gable:

**Step 1:** Study the entire set of architectural and fabrication drawings.

**Step 2:** Follow steps 2 to 6 of **Section 7.4.1** on Hip end construction

**Step 3:** Stand the Dutch gable truss orientated with the webs of the truss facing toward the hip end wall. The rafter support rail is oriented with the toes facing away from the hip end wall. (i.e. the same as the truncated truss chords). This provides a secure fixing of the rafter to the support rail.

**Step 4:** Fix the truss to the heel brackets as per Hip end construction.

**Step 5:** Temporarily brace the truss plumb and straight.

**Step 6:** Install the Hip rafters as per step 8 of **Section 7.4.1** on Hip end construction fixing the rafter to the wall, truncated trusses and Dutch gable truss using the details shown.

**Step 7:** Install Jack rafters where shown on the truss layout in accordance with step 9 of **Section 7.4.1** on Hip end construction.

**Step 8:** Creeper rafters are supported by the hip rafter and the external wall. They are generally short rafters near the corner of the building. Ensure sufficient back span is provided to give the installed rafter sufficient strength. Mark the overhang length on the creeper rafters as per the jack rafters. Install the creeper rafters in the locations shown on the layout drawing fixing to the creeper rafter and the wall top plates as shown in **Figure 7.26**.

Fix creeper rafter to hip rafter as shown in **Figures 7.25** to **7.27**.

**Step 9:** If not factory installed, fix battens to the Dutch Gable truss Chords to suit the fixing requirements of the Dutch gable end cladding. These battens should be spaced to suit claddings and designed to suit the length and loading criteria.

**Note:** When all trusses are erected, install wind bracing as specified in **Section 7.9** on Roof Bracing.

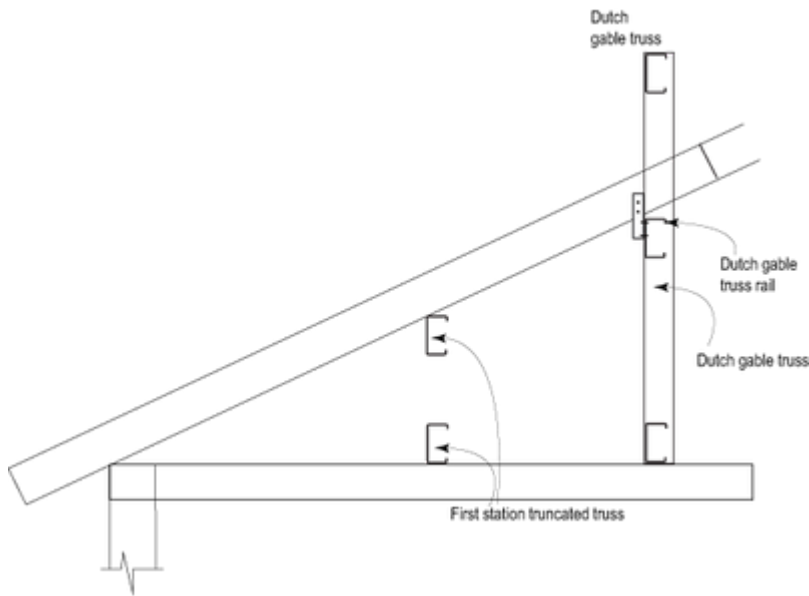


Figure 7.55 Dutch gable truss section view

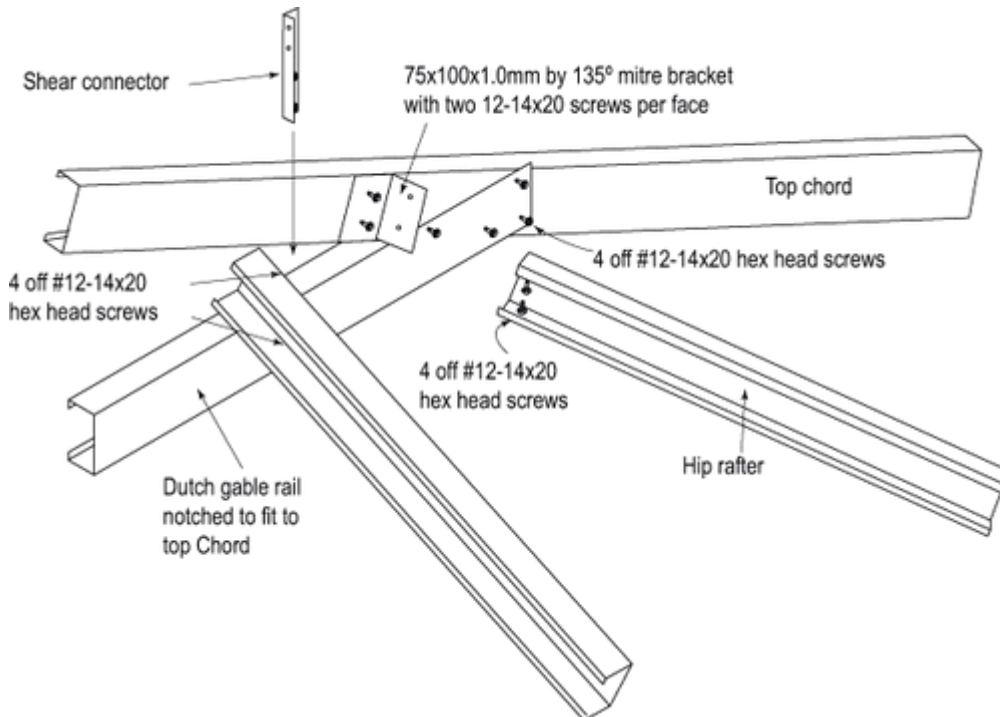
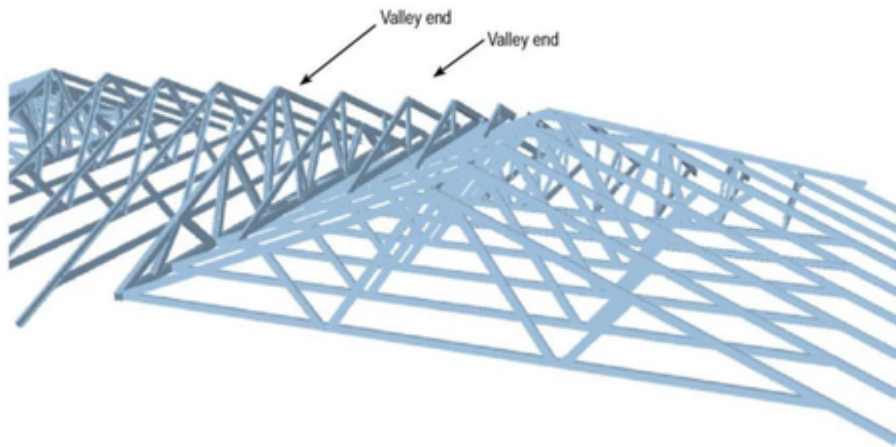


Figure 7.56 Dutch gable rail to top chord connection

## 7.6 Valley end construction



**Figure 7.57: Valley end connection**

**Figure 7.57** shows a typical arrangement for bridge trusses supported by a girder truss. Saddle trusses are placed over the bridge trusses to infill the void and form the ridge line. This combination of bridge girder and saddle truss set is called a valley end.

**Table 7.8.5 Limit State Design Loads for Pryda® TBJ45 Bracket (Bridge Truss to Girder Truss)**

Top Chord	Bottom Chord	Fasteners Bracket to Girder Truss	Fasteners Bracket to Bridge Truss
0.75mm Boxed	0.75mm Boxed	8x#12-14x20	8x#12-14x20
1.0mm Boxed	1.0mm Boxed	8x#12-14x20	8x#12-14x20

### 7.6.1 Girder-bridge truss connection

To connect bridge trusses to a girder truss:

- Step 1:** Study the entire set of architectural and fabrication drawings.
- Step 2:** Set out and mark truss positions as per **Section 7.2**.
- Step 3:** Mark the bridge truss positions on the bottom chord of the girder truss as specified on the girder truss fabrication sheet.
- Step 4:** Install fixing brackets to the wall top plates to fix girders, bridge trusses and rafters in marked positions.
- Step 5:** Attach Pryda TBJ45 brackets to the web of the girder truss bottom chord in the marked positions.

**Note**

**Note:** Girder truss bottom chords are always boxed to allow the Pryda TBJ45 brackets to be fixed to the web of the bottom chord.

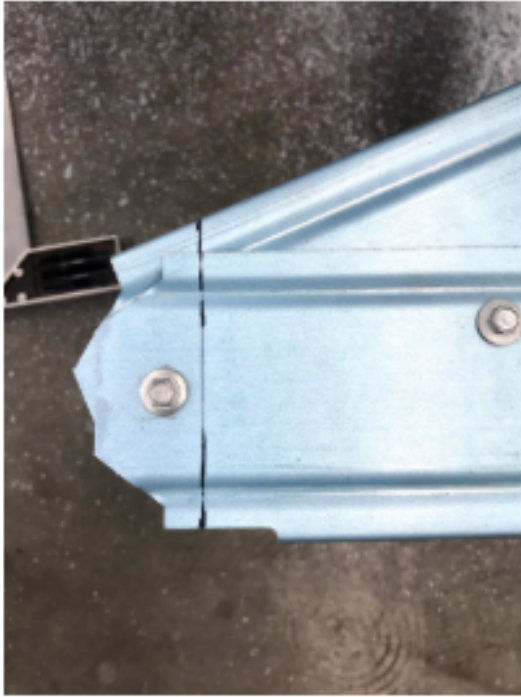
**Step 6:** Install the first ply of the girder truss which has the Pryda TBJ45 bridge brackets installed and fix it to the hold down bracket at the heels.

**Step 7:** Temporarily brace the girder truss and ensure that it is plumb and straight. This can be done using batten or roof bracing material fixed to the end wall and to the top chord of the truss.

### 7.6.2 Assembling Bridge Trusses

Trim the bridge trusses at the intersection of the top and bottom chords as shown below in **Figure 7.58**.





Before Trimming



After Trimming

Bridge trusses are trimmed at intersection of top and bottom chords. The Trussbite is removed and replaced with 2 x 12-14x20 hex heads, as well as any additional fasteners required.

**Figure 7.58: Bridge truss before and after trimming**

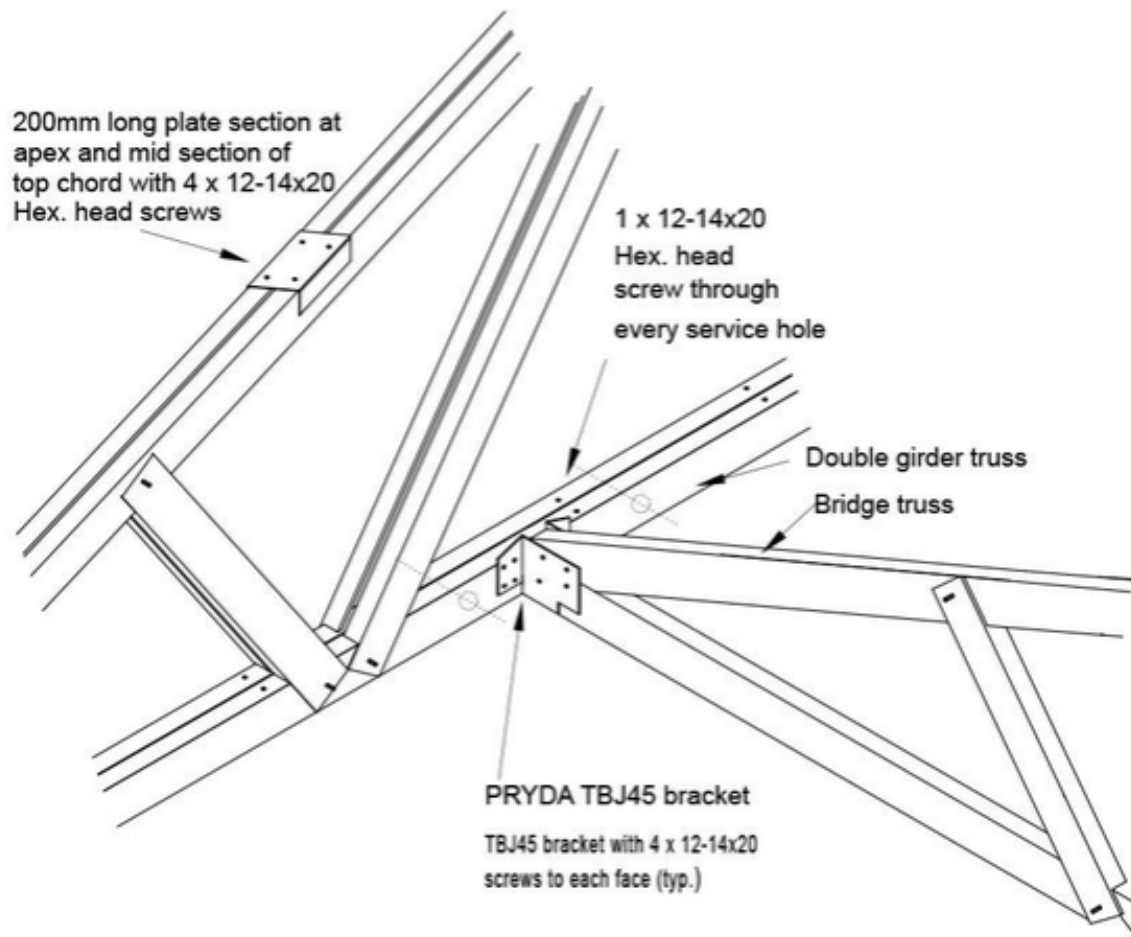
**Note**

**Note:** The trim location is 34mm from the end of the bottom chord. Once the heel is trimmed, a TBJ45 bridge bracket is fitted to connect the truss to a beam or girder truss.

**7.6.3 Installing Bridge Trusses onto Girder Trusses**

Install the bridge trusses to the external wall and girder truss as shown in **Figure 7.59**.





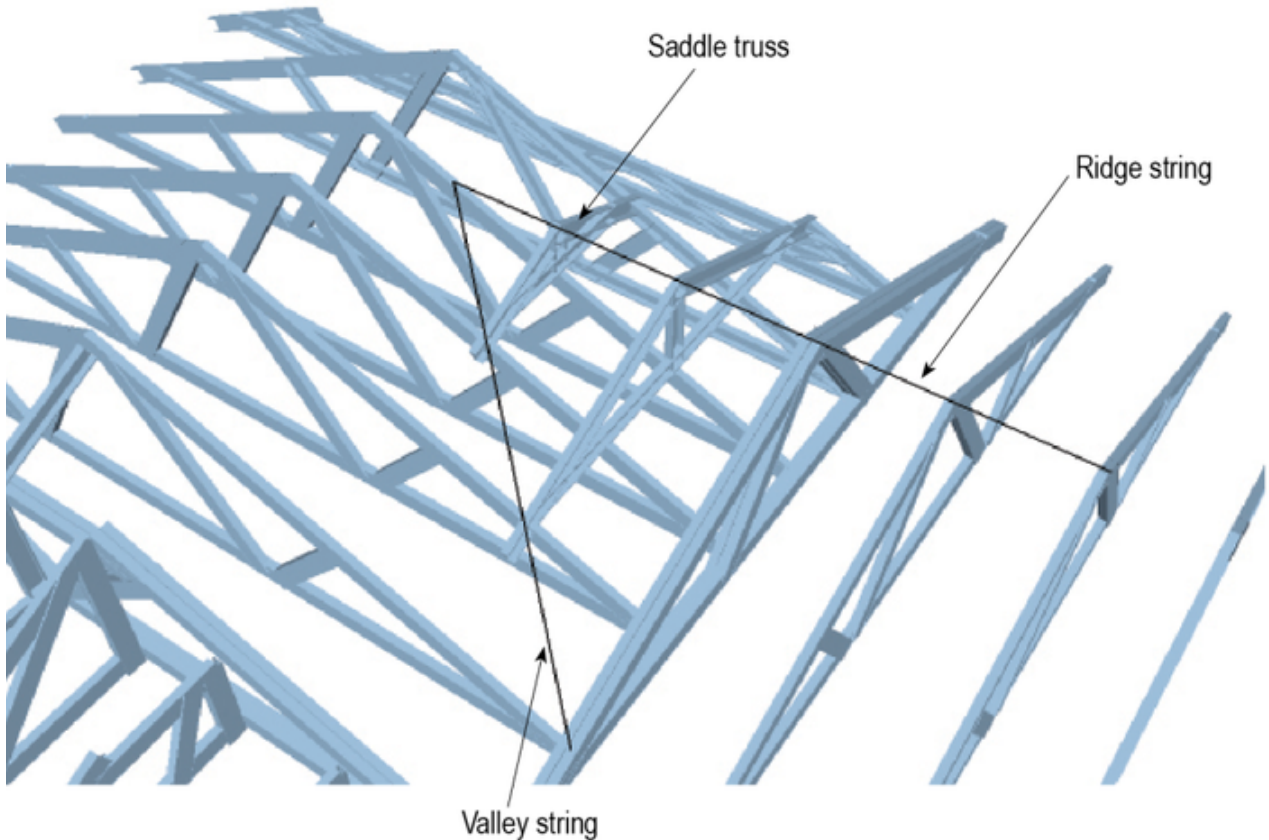
**Figure 7.59: Bridge truss to girder truss connection using Pryda TBJ45 bracket**

**Step 1:** Install the second ply girder truss (if applicable) with the toes of both trusses facing each other and fix it to the brackets as shown in **Figure 7.13** and **7.14**.

**Step 2:** Install 1x12-14x20 Hex Head screw through **EVERY** service hole provided on the bottom chord to connect the two trusses together as shown in **Figure 7.59**.

**Step 3:** Install 200mm long plate sections with 4x12-14x20 hex- head screws to the top chord near the apex and midspan.

#### 7.6.4 Saddle truss construction



**Figure 7.62: Saddle truss detail**

To install saddle trusses:

**Step 1:** Study the entire set of architectural and fabrication drawings.

**Step 2:** Fix a string line along the ridge line of your roof and down the valley lines to aid in the positioning of saddle trusses as shown in **Figure 7.62**.

**Step 3:** Position the largest saddle truss keeping it parallel to the edge of the main roof. With the open face of the bottom chord facing down the slope and the webs facing up the slope, adjust the truss positions so that the long points of the foot cut line up with the valley string lines.

**Step 4:** When the saddle truss is standing plumb, the apex line should line up with the apex string line.

**Step 5:** Fix the bottom chord of the saddle trusses to the top chord of the underlying truss with an angle bracket as shown in **Figure 7.64**.

**Step 6:** Repeat steps 3, 4 and 5 for subsequent saddle trusses until the saddle block is complete.

**Step 7:** Temporarily brace the apex of the saddle trusses.

**Note**

**Note:** The smallest saddle truss will require a trimmer to be installed below it for extra support as shown in **Figure 7.63**.

**Note**

**Note:** When all trusses are erected, install wind bracing as specified in **Section 7.9** on Roof Bracing.

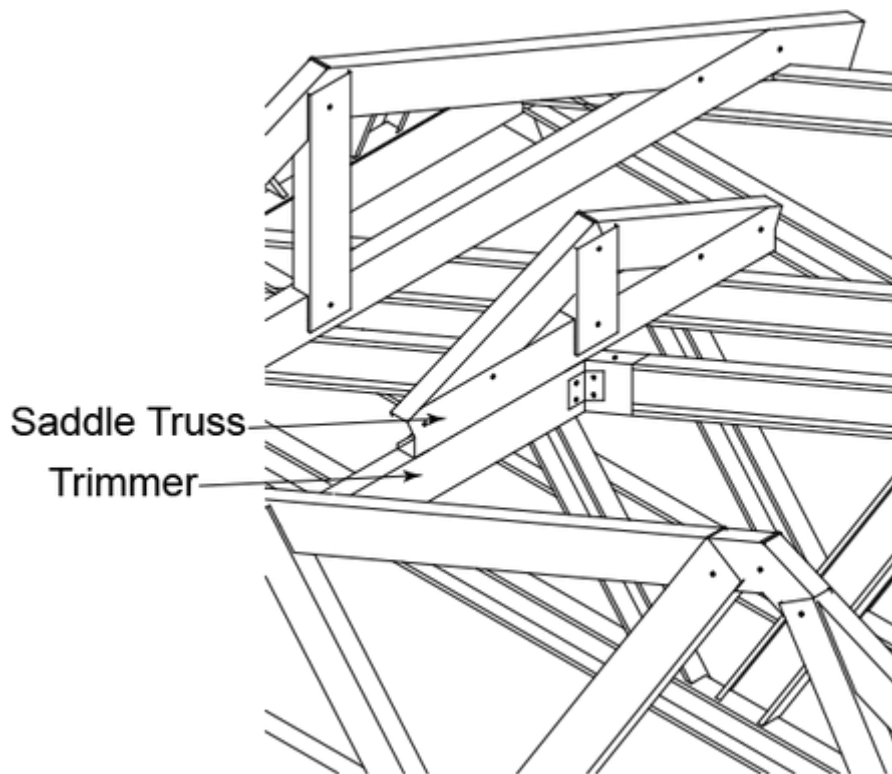


Figure 7.63: Saddle truss trimmer detail

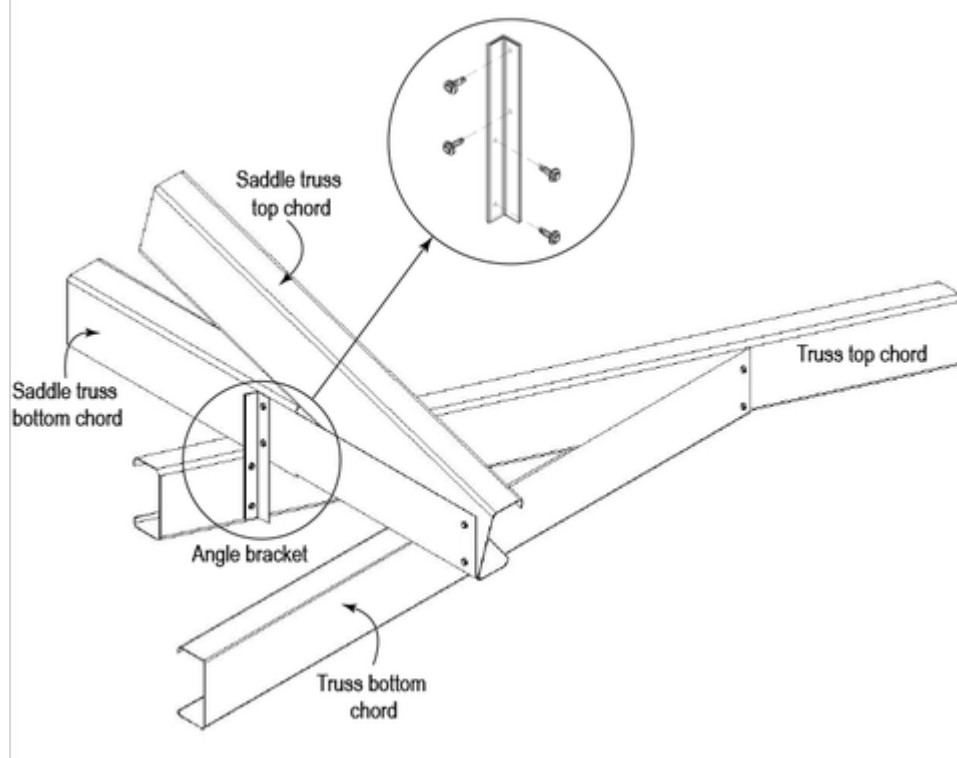
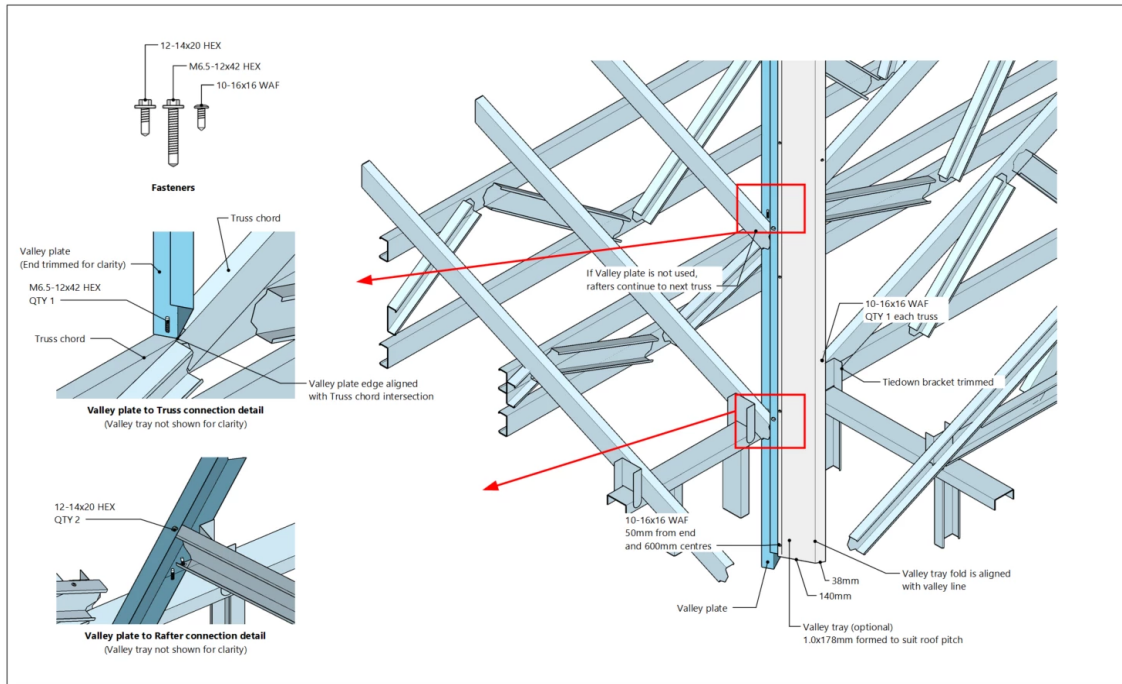


Figure 7.64: Saddle truss connection

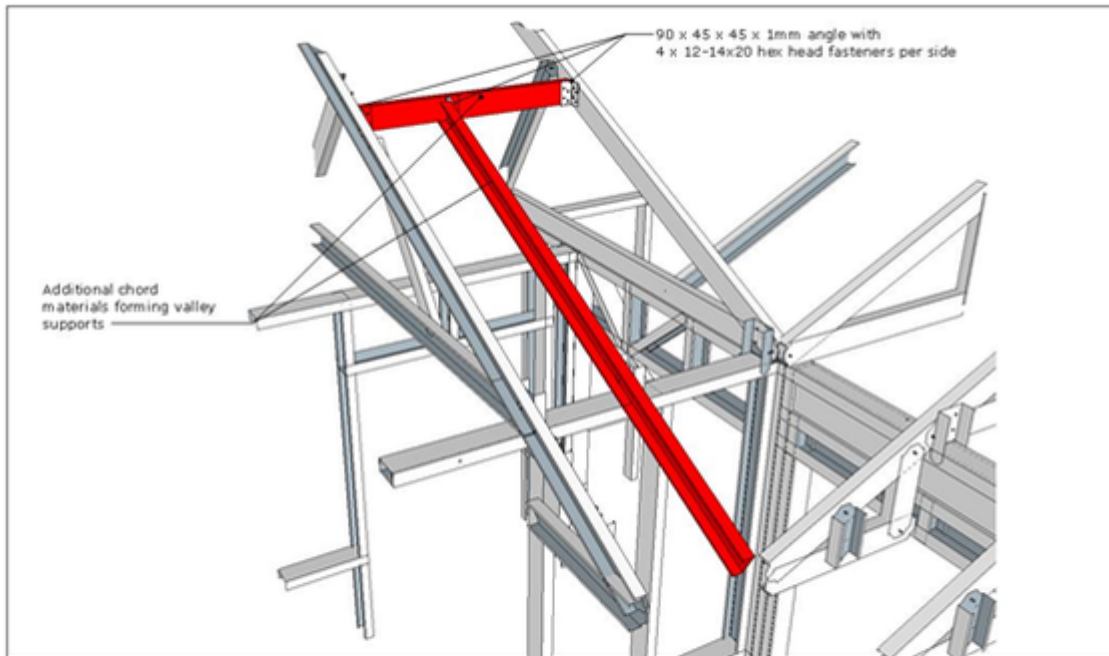
### 7.6.5 Valley Installation

Valley installation using a valley plate is shown in the detail below:-



<b>ENDURO FRAME®</b>	<b>Valley with Valley plate and optional Valley tray</b>	REVISIONS		01 A	
	Installation Drawing	DDMM/YYYY	REMARKS		
		1	12/06/2020		ENDUROCAD® software v11.01.02
		2			

At the lower end of a valley junction, a rafter fabricated from scrap material can be placed to provide support for the fascia. Minimum section size to be the same as for common rafters required for the required span and overhang as specified in the Enduroframe design manual. Refer to graphic below.



<b>VALLEY SUPPORT</b>	<b>TLA</b>	REVISIONS		01 A
	PROJECT TITLE	1	12/06/2020	
		2		
		3		

### 7.6.6 Radial Roof

A diagrammatic representation explaining the various elements of a radial truss is shown in **Figure 7.68**. Radial trusses consist of the following elements:

**Girder truss.** This is the same as standard girder trusses.

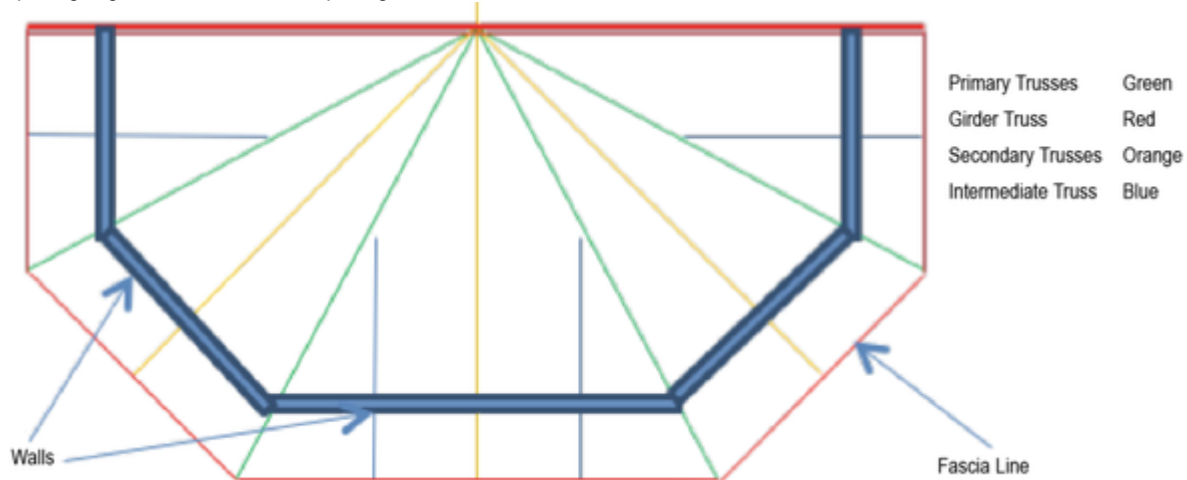
**Barrel.** This is connected to two vertical members on the girder truss and rotates around. A picture of the barrel including dimensions is shown in **Figure 7.69**.

**Primary trusses.** These are half trusses attached to the barrel radiating out from a central point on the girder truss and sit at the hip corners of the roof.

**Note:** the max length for half trusses to be used is 6m.

**Secondary trusses.** These are half trusses that are in between the primary trusses. They are placed when the Primary truss spacing exceeds the standard truss spacing in between the primary trusses at the eave line and may be attached to the face of the Barrel. These trusses typically remain perpendicular to the pitching line.

**Intermediate trusses.** These are the remaining trusses that are may be required between the Primary and Secondary trusses if the spacing is greater than the truss spacing at the eave.



**Figure 7.65: Radial truss key components**

#### Radial roof construction

To install a radial roof:

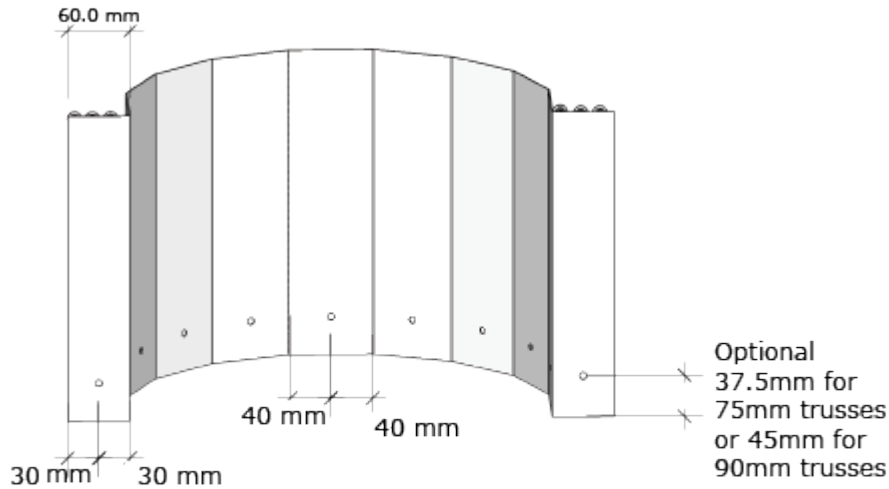
**Step 1:** Study the entire set of architectural and fabrication drawings. The Truss components in this area include the Girder, Primary, secondary and intermediate flush trusses.

**Step 2:** Set out and mark truss positions as per **Section 7.2**.

**Step 3:** If the Barrel(s) (pressed metal bracket(s)) have been sent as loose items, please fix to Girder truss as per the drawing below. The flat face of the girder truss provides a smooth face to attach 2 vertical rails which, in turn, support the barrel(s). Depending on the height of the truss will depend if there are one or two barrels. The lower barrel will be connected with a Trusstite through a pre-punched self-locating hole in the barrel, which is aligned with a self-locating hole in the vertical section and the truss chord. A total of 5 screws with either 12-14x20 hex head fasteners or 1 x Trusstite and 4x12-1x20 fasteners attached on each side of the barrel into the vertical section. The top barrel will usually be site fixed so the top chords of the half trusses do not clash, and will be fixed with 5x12-1 4x20 hex head fasteners.

**Step 4:** Install fixing brackets to support structure in marked positions.

**Step 5:** Lift Girder into set-out position. And fix two #12-14x20mm hex head self-drilling screws through the fixing bracket at each heel connection into the truss Chord. If erection screws positions clash with truss manufacture fasteners remove these screws and replace with the erection screws through the bracket and into the chords in the same location.



All holes are in the center of each segment of the barrel and are located 37.5mm from the end for a C75 truss or 45mm for a C90 truss

**Figure 7.66: Barrel Brackets Details**

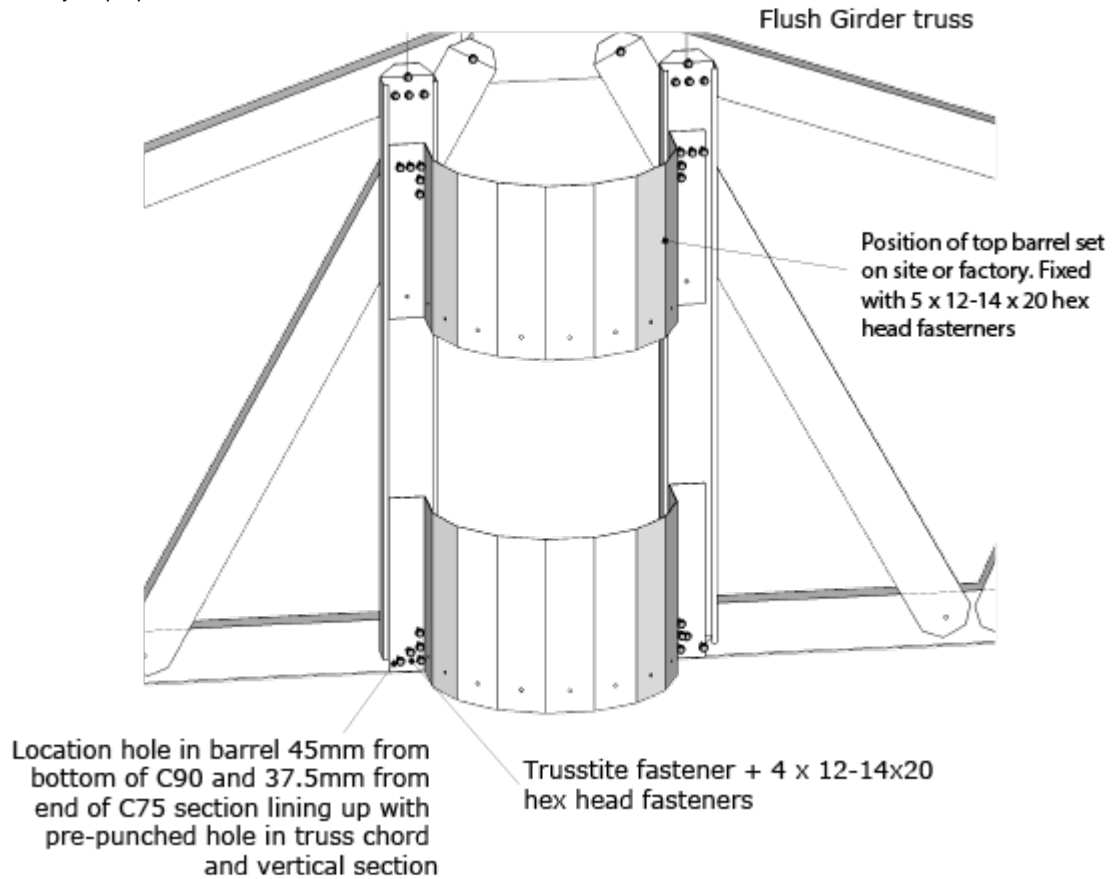
**Step 6:** Temporarily brace the truss and ensure it is plumb and straight. This can be done using batten or roof bracing material fixed to the end wall and to the top chord of the truss.

**Step 7:** The Hip trusses (noted as the primary trusses) are next. Lift and place as per set out. Most commonly these hips run over the corners of the building. They are to be attached at the wall frame as per **Figures 7.24** and **7.26**. Depending upon the wind, dead load and span fixings needed. At the barrel end of the hip (primary) trusses, the bottom chord has a tab extending 40mm past the vertical chord. This is manually bent 90 degrees so the 6mm locating hole can be used to align the bottom of the truss to pre-punched holes in the barrel to get the correct height. The top chord on the other hand extends and runs over the barrel to give a more complete hip line and for battens to connect to. Half trusses are connected onto the face of the barrels with an additional 4x12-14x20 hex head fasteners as per **Figure 7.71** and **7.72**. Or If not using the Trusstite use 5x12-14x20 hex head fasteners. The load from the half truss is transferred to the barrel with these fasteners.

**Note**

These fastenings can be made from front or back faces of the barrel.

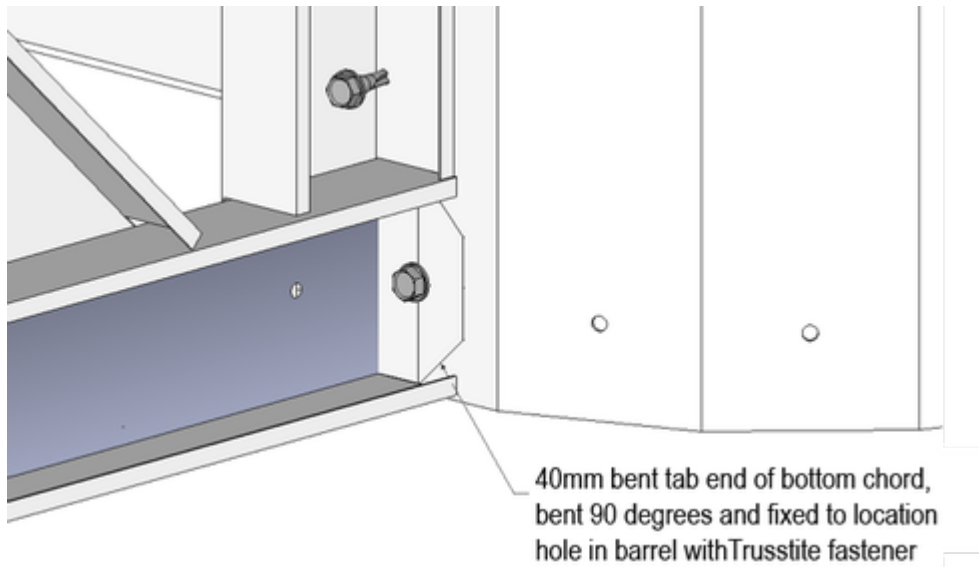
**Step 8:** Lift the secondary trusses following the same set out as step 7 and the same process where it meets the barrel but will actually sit perpendicular to the wall frame and can be attached to the wall frame with hold down methods suitable.



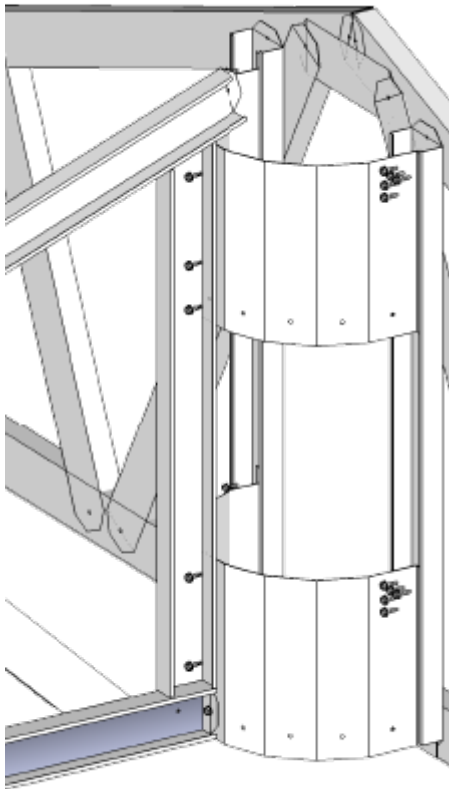
**Figure 7.67: Position of barrels on vertical section**

**Step 9:** Lift the remaining intermediate trusses into their required position and use the same tie down fixing on the wall frame as per the secondary trusses. Where these intermediate trusses join to the primary trusses ensure that some partial boxing plate is added (to the open side of the primary truss) and fixed with 4x12-14x20 hex head fasteners through the flanges towards the ends of this piece. These intermediate trusses have an extension to the top chord that will manually need to be bent to fix to the primary truss as this area. This bent tab is attached with 2x2-14x20 fasteners through this top chord extension into the top chord of the oncoming truss. The bottom chord also is extended of this intermediate truss and follows the same partially boxing method as just described. Refer to **Figures 7.73** and **7.74**.





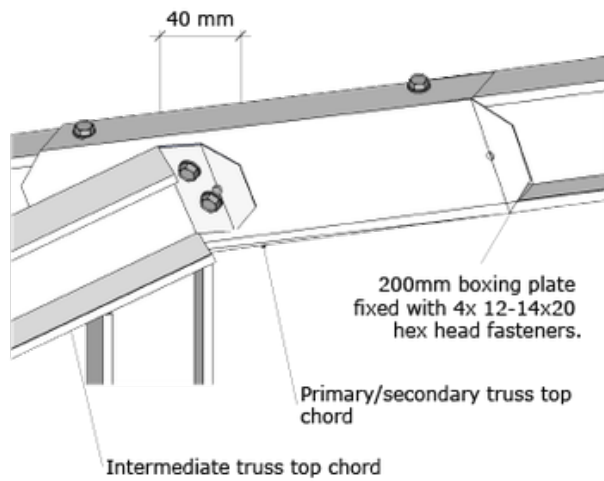
**Figure 7.68: Bend tab at end of half truss to locate the bottom chord onto a pre-punched hole in the barrel**



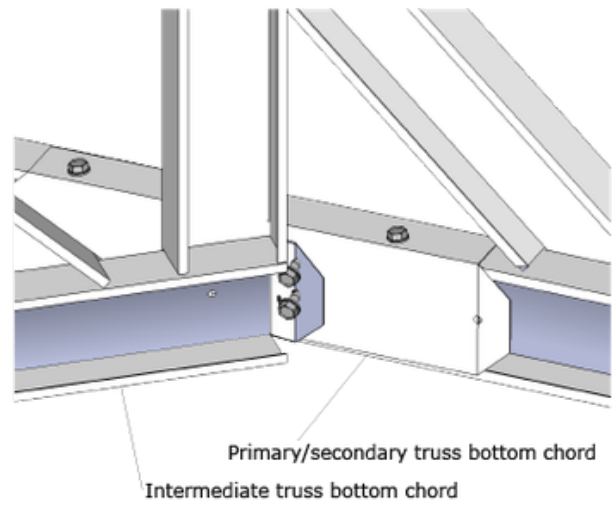
**Figure 7.69: Connecting half trusses to barrels with 1 x Trusstite and 5 x 12-14x20 hex head fasteners**

Half trusses are connected onto the face of the barrel with an additional 5 x 12-14x20 hex head fasteners as per **Figure 7.65**. The fasteners can be screwed through the back of radial to truss if required. The load from the half truss is transferred to the barrel with these fasteners. Fasteners can also be installed from back of barrel.

The end of the intermediate truss top chord extends past the primary truss by 40mm. It is notched on both flanges and is manually bent, and attached with 2 x 12-14x20 hex head fasteners.

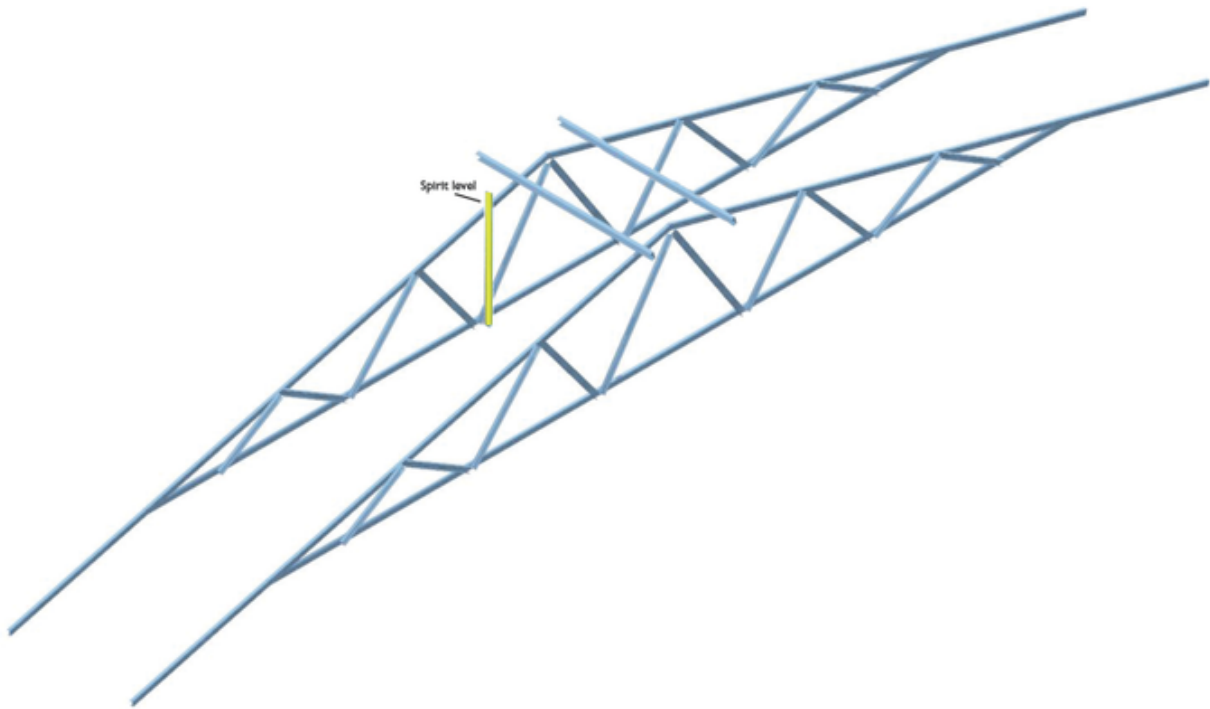


The end of the intermediate truss bottom chord extends past the primary truss by 40mm. It is notched on both flanges and is manually bent, and attached with 2 x 12-14x20 hex head fasteners.



**Figure 7.70: Connection between primary and intermediate truss (Top Chord)** **Figure 7.71 Connection between primary and intermediate truss (Bottom Chord)**

## 7.7 Common roof block construction



**Figure 7.72: Use spirit level to plumb truss**

To install common roof blocks:

**Step 1:** Study the entire set of architectural and fabrication drawings.

**Step 2:** Mark out truss positions on the top plate as per the Roof Framing Layout. Refer to **Section 7.2** on Roof Truss Set-Out.

**Step 3:** Install gables, hips and Dutch gables in accordance with **Sections 7.3, 7.4** and **7.5** of this manual. Install remaining trusses in their set-out positions and secure using two #12-14x20mm hex head tek screws through the fixing bracket at each heel connection into the side of the top plates. Temporarily brace as close as possible to the apex of each truss to plumb and straighten.

**Note:** To keep trusses in-line, simply maintain a straight line at the apex of all trusses this can be done using a string line. Alternatively, run a string line along a common point on the trusses.

**Note:** When all trusses are erected, install wind bracing as specified in **Section 7.9** on Roof Bracing.

## 7.8 Truss and Rafter Tie Down Connections

The designer should specify the tie down system to be used for each job with reference to ENDUROCAD® truss and rafter reactions and standard connection design capacities. The truss and rafter reactions to be resisted are calculated by the ENDUROCAD® software, however a ready reckoner on the reactions to be resisted under a range of roof truss spacings, spans and wind loads are shown in **Tables 7.8.2a, 7.8.2b and 7.8.2c**. Note that these tables may be more conservative than the values calculated by the ENDUROCAD® software.

**Table 7.8.2a. Truss Downward Reactions for a Tile Roof in a non-cyclonic region**

1000mm Overhang	TRUSS DOWNWARD REACTIONS AT TOP PLATE (KN) UNDER TILE ROOF								
Truss Span	TRUSS CENTRES (mm)								
	600			900			1200		
	N1	N2	N3	N1	N2	N3	N1	N2	N3
4	3.08	3.39	4.02	4.42	4.89	5.84	5.76	6.39	7.66
5	3.50	3.86	4.59	5.06	5.60	6.69	6.62	7.33	8.79
6	3.93	4.33	5.15	5.70	6.31	7.53	7.47	8.28	9.91
7	4.36	4.81	5.71	6.35	7.02	8.38	8.33	9.23	11.04
8	4.79	5.28	6.28	6.99	7.73	9.22	9.19	10.17	12.17
9	5.22	5.75	6.84	7.63	8.44	10.07	10.04	11.12	13.30
10	5.64	6.23	7.41	8.27	9.15	10.91	10.90	12.06	14.42
11	6.07	6.70	7.97	8.92	9.86	11.76	11.76	13.01	15.55
12	6.5	7.17	8.53	9.56	10.56	12.61	12.61	13.96	16.68
13	6.93	7.65	9.10	10.20	11.27	13.45	13.47	14.90	17.81
14	7.36	8.12	9.66	10.84	11.98	14.30	14.33	15.85	18.93
15	7.79	8.59	10.22	11.49	12.69	15.14	15.18	16.80	20.06

**Table 7.8.2b Truss Uplift Reactions at Top Plate under a Sheet Roof – Non-Cyclonic**

1000mm Overhang	TRUSS UPLIFT REACTIONS AT TOPPLATE (KN) UNDER SHEET ROOF								
Truss Span	TRUSS CENTRES (mm)								
	600			900			1200		
	N1	N2	N3	N1	N2	N3	N1	N2	N3
4	1.16	1.77	3.00	1.74	2.65	4.50	2.32	3.54	6.00
5	1.32	2.02	3.43	1.98	3.02	5.14	2.64	4.03	6.85
6	1.48	2.26	3.85	2.22	3.40	5.78	2.96	4.53	7.70
7	1.64	2.51	4.28	2.46	3.77	6.41	3.28	5.02	8.55
8	1.80	2.76	4.70	2.70	4.14	7.05	3.60	5.51	9.40
9	1.96	3.00	5.13	2.94	4.51	7.69	3.91	6.01	10.25
10	2.12	3.25	5.55	3.17	4.88	8.33	4.23	6.50	11.10
11	2.28	3.50	5.98	3.41	5.25	8.96	4.55	7.00	11.95
12	2.43	3.74	6.40	3.65	5.62	9.60	4.87	7.49	12.80
13	2.59	3.99	6.83	3.89	5.99	10.24	5.19	7.98	13.65
14	2.75	4.24	7.25	4.13	6.36	10.88	5.50	8.48	14.50
15	2.91	4.49	7.68	4.37	6.73	11.52	5.82	8.97	15.35

**Table 7.8.2c Truss Uplift Reactions at Top Plate under a Sheet Roof – Cyclonic**

1000mm Overhang	Truss Uplift Reactions at Top Plate under a Sheet Roof – Non-Cyclonic

Truss Span	TRUSS CENTRES (mm)					
	600			900		
	C2	C3	C4	C2	C3	C4
4	6.01	9.04	12.36	9.02	13.56	18.54
5	7.01	10.55	14.42	10.52	15.83	21.63
6	8.01	12.06	16.48	12.02	18.09	24.72
7	9.02	13.56	18.54	13.52	20.35	27.81
8	10.02	15.07	20.60	15.03	22.61	30.90
9	11.02	16.58	22.66	16.53	24.87	33.99
10	12.02	18.09	24.72	18.03	27.13	37.08

**Note:**

- 1) The wind pressure coefficients to determine Truss Uplift Reactions are based on AS 4055-2011 Table 3.1
- 2) Truss uplift reactions are based on most critical design conditions (slope, input parameters of Pressure Coefficients from AS 4055 etc.).
- 3) Accurate uplift reactions to suit the truss /building layout configuration and AS 1170.2 wind pressure coefficients can be obtained from ENDUROCADD® Software Engineering sheet output.

Based on the reactions selected from **Tables 7.8.2a, 7.8.2b or 7.8.2c** an appropriate tie down shall be selected. The selection of an appropriate tie down depends on a number of factors:-

1. The thickness of the truss chord;
2. The thickness of the top plate;
3. The thickness of the stiffening piece;
4. Whether the trusses are landing in between studs, are directly tied to a stud or above a 200 x 30 x 1.5mm lintel;
5. The type of tie down selected;
6. The tie down should be selected AFTER the truss, top plate, stud, and stiffener thicknesses have been determined, and whether the studs are aligned under trusses or will be attached to a 1.5mm thick lintel. The top plate should be checked for truss downward reactions. The tie downs can be selected in the ENDUROCADD® software and shown on tie down sheets, however **Table 7.8.3** can also be used as a guide based on a selection of truss and wall frame configurations.

**Table 7.8.3 – Connection Capacity of various configurations of truss chords, studs, top plates and tie downs**

Top Plate Thick	Min. Truss Chords Thick	Top plate stiffener used	Min. Stud & Stiffener Thick	Connection Capacity (kN)									
				Tie Down type***									
				A	2A	B	2B	C	2C	D	E	F	
0.75	0.75	Yes	0.75	3.8	5.6	4.9	5.6	5.6	5.6		-		
1.0	0.75	Yes	1.0	3.8	7.6	4.9	8.5	8.4	8.5		-		
1.0	0.75	Yes	1.2	3.8	7.6	4.9	9.3	8.4	9.3		-		
1.0	1.0	Yes	0.75	4.4	7.4	6.0	7.4	7.4	7.4		-		
1.0	1.0	Yes	1.0	4.4	8.5	6.0	8.5	8.5	8.5		-		
1.0	1.0	Yes	1.2	4.4	8.8	6.0	9.3	9.3	9.3		-		
1.2	0.75	Yes	0.75	3.8	7.4	4.9	7.4	7.4	7.4		-		
1.2	0.75	Yes	1.0	3.8	7.5	4.9	9.6	8.4	9.6		-		
1.2	0.75	Yes	1.2	3.8	7.5	4.9	9.8	8.4	12.3		-		
1.2	1.0	Yes	0.75	4.4	7.4	6.0	7.4	7.4	7.4		-		
1.2	1.0	Yes	1.0	4.4	8.8	6.0	9.6	9.6	9.6		-		
1.2	1.0	Yes	1.2	4.4	8.8	6.0	12.0	12.3	12.3		-		
0.75*	1.0	No	0.75								27	-	
0.75	1.0	No	1.0	-	-	-	-	-			23.7		
NA**	0.75	NA	NA	-	-	-	-	-				18.6	

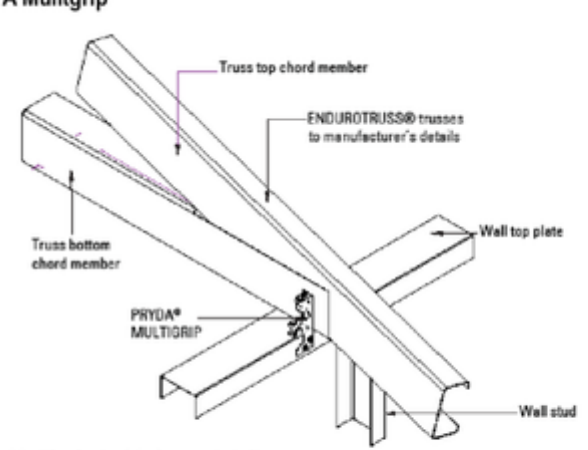
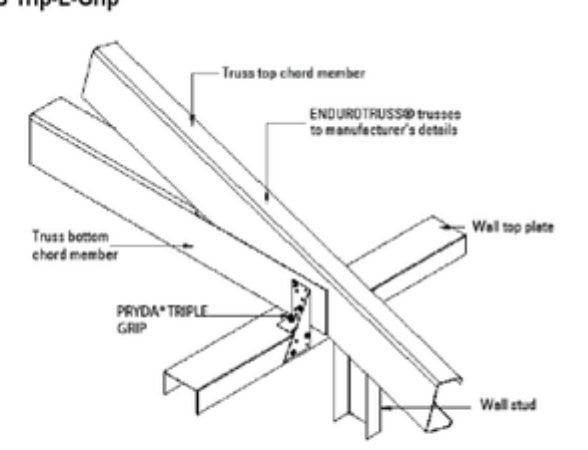
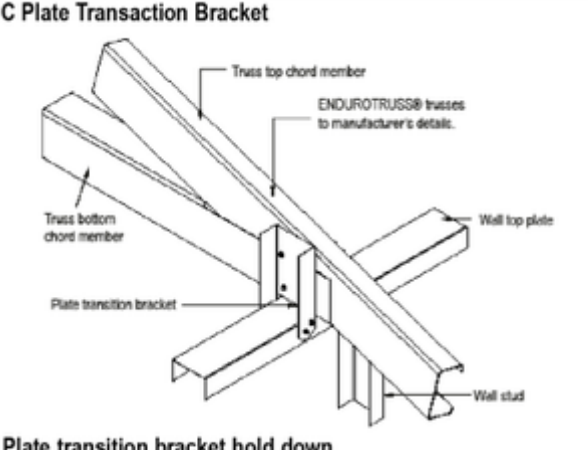
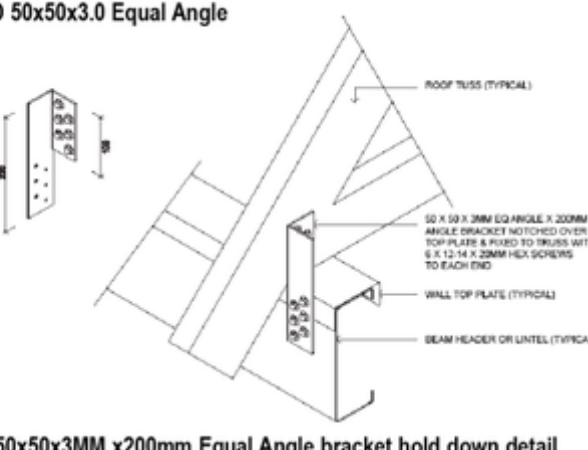
Each option assumes that the plates are connected to studs with 1 x M6x1Px15mm smooth top fastener on each side of the plate.

- Option requires a 200 x 35 x 1.5mm lintel to be installed.
- For bolting to a masonry wall or structural steel connection with a minimum M12 bolt through a 50 x 3mm square washer.

A 2 in front of the connection type denotes a double connection into a boxed section.

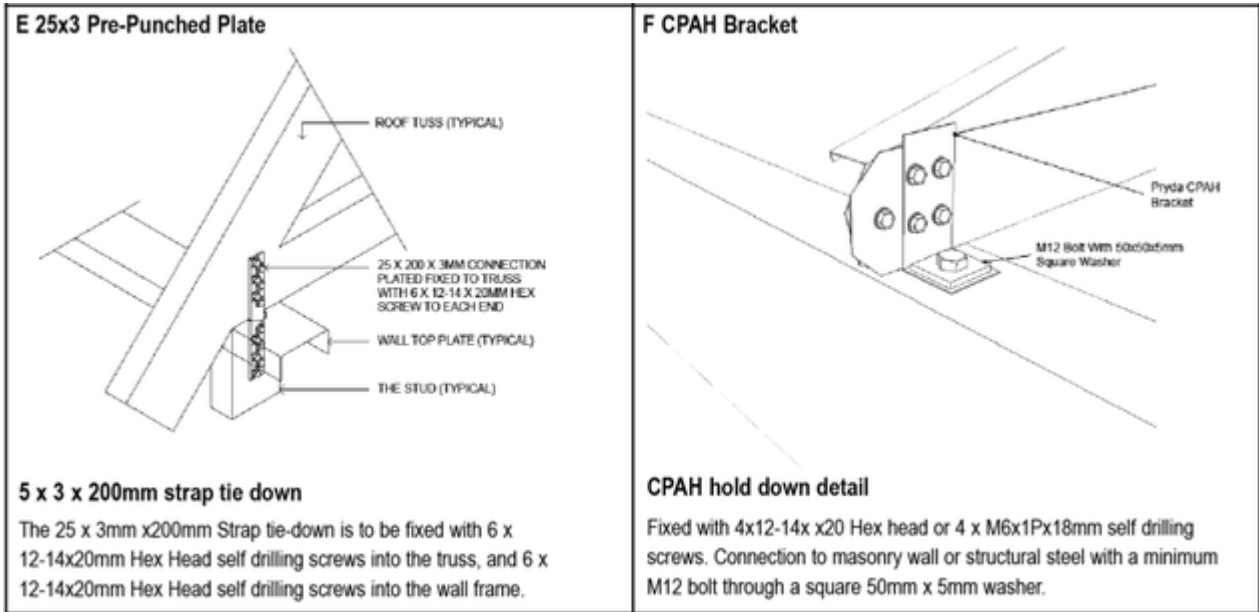
**A description of the Tie Down types is shown in Table 7.8.4**

Table 7.8.4

<p><b>A Multigrip</b></p>  <p><b>Multigrip hold down detail</b> 2 x #12-14x20 hex head fasteners or 2 x M6 x 1P x 18mm Smooth top tek fasteners into both truss and top plate for a total of 4 fasteners per Multigrip.</p>	<p><b>B Trip-L-Grip</b></p>  <p><b>Triple-L-Grip hold down detail</b> 2 x #12-14x20 hex head fasteners or 2 x M6 x 1P x 18mm Smooth top tek fasteners into both truss and top plate into both truss and top plate for a total of 6 fasteners per Triple-L-grip.</p>
<p><b>C Plate Transition Bracket</b></p>  <p><b>Plate transition bracket hold down</b> 4 x #12-14 x 20 hex head fasteners between bracket and truss, and 2 x M6x1Px18mm Smooth Top Tek screws from bracket into each side of top plate for a total of 8 fasteners. Transition part thickness must have the same minimum thickness as the top plate.</p>	<p><b>D 50x50x3.0 Equal Angle</b></p>  <p><b>50x50x3MM x200mm Equal Angle bracket hold down detail</b> The 50 x 50 x 3mm x200mm Equal Angle bracket hold down is to be fixed with 6x12-14x20 Hex head or 6xM6 x 1P x 18mm self drilling screws into both the truss and the wall frame for a total of 12 screws.</p>

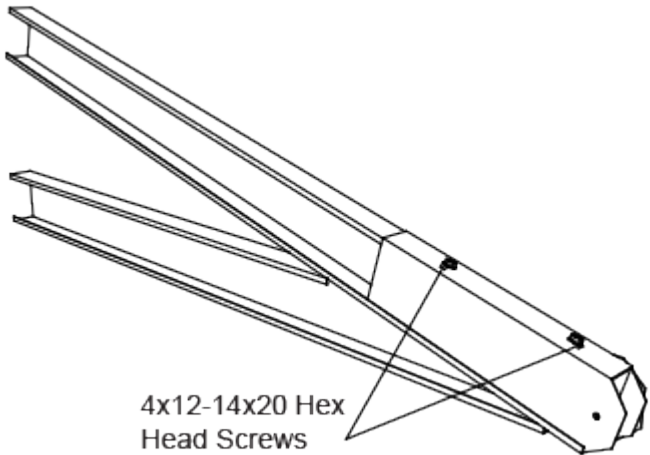
The ENDUROGRIP bracket can be used in place of the transition part hold down.



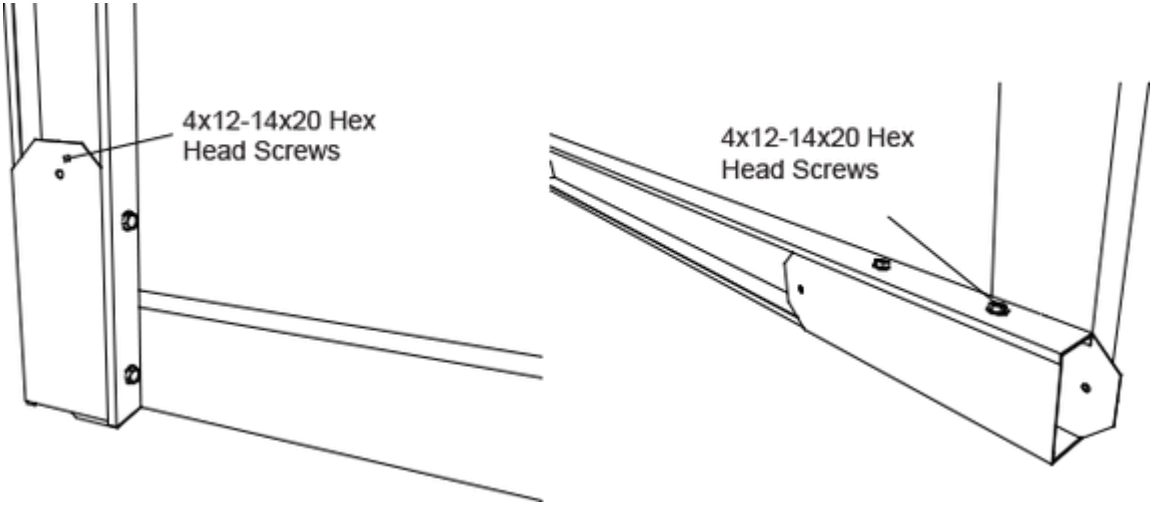


**7.8.1 Boxed Tie Downs**

To attach a tie down to the reverse side of a truss or rafter the section will need to be boxed with a 200mm long boxing piece. This boxing piece can be cut back from a piece of scrap steel and attached to the truss. For apex trusses the boxing piece will be connected to the top chord of the trusses as per **Figure 7.76**. For half trusses with vertical chords the boxing plate may be attached to either the vertical or horizontal chords as per **Figure 7.77**.

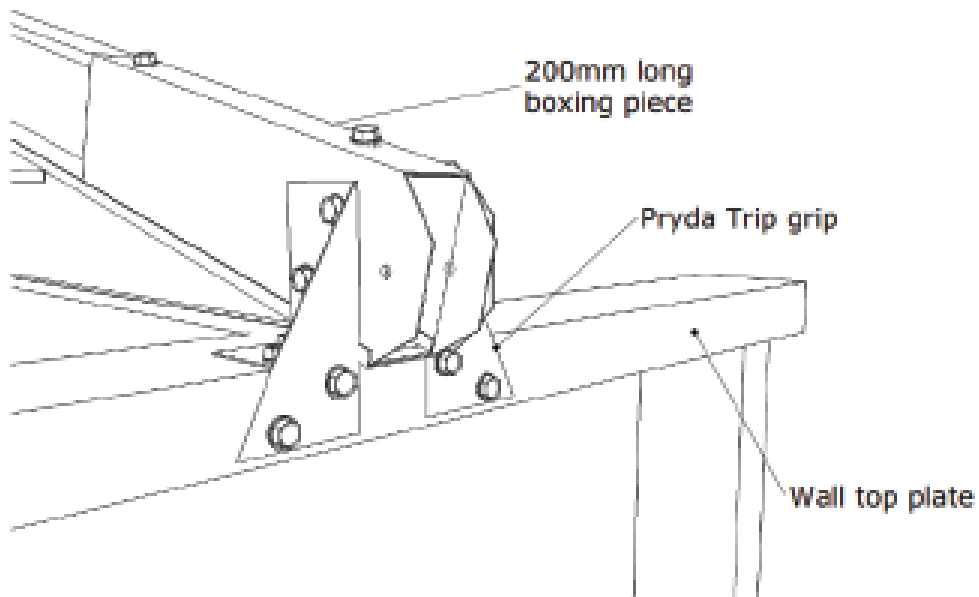


**Figure 7.73: Boxing piece to truss top chord**



**Figure 7.74: 200mm boxing piece fixed to either horizontal or vertical chords on a half truss**

Tie downs are then fixed to the boxing piece using the quantities of fasteners shown in **Table 7.8.4** for the respective tie downs. An example of the tie down methodology is shown in **Figure 7.78** for triple grips. Other tie downs are fixed in a similar manner.



**Figure 7.75: Fixing double tie downs to truss and top plate (Triple grips shown)**

## 7.9 Truss restraints

Truss restraints are rollformed U or L sections which span between adjacent truss chords (or wall and truss chord) and help restrain trusses during truss installation, making truss installation much quicker and easier by removing the need to use battens to restrain the trusses once they are stood. Truss restraints only span between chords or wall top plates that are on the same horizontal plane, and are not inserted where there is a change in the ceiling plane (ie. where there is a coffered ceiling adjacent to a flat ceiling) or a change in the roof plane (ie. at hip ends).

Truss restraints can also:

- substitute for ceiling trimmers where there are no ceiling battens used
- serve as permanent bottom chord restraints where there are no ceiling battens
- provide restraint for non-load bearing walls that run parallel and in between roof trusses.

**Warning:** Under no circumstances should the truss restraint be considered suitable to step on during installation.

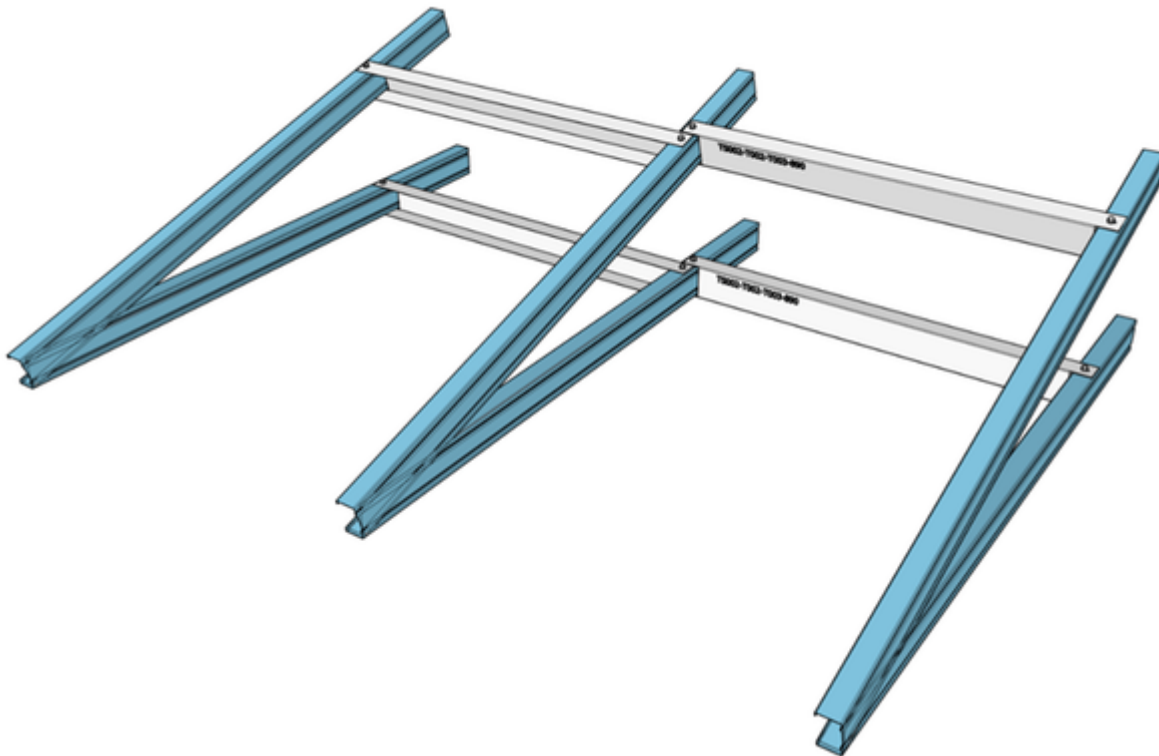


Figure 7.76: U section and angle section truss restraints

### 7.9.1 Identifying truss restraints

Truss restraints can be **Common** or **Unique**. Common truss restraints are for the default truss spacing that the designer has used to design the roof, eg. 600mm, 900mm or 1200mm spacings. This will be the majority of the truss restraints that are used on a job and can be used between any pair of trusses that have this spacing.

Unique truss restraints are used when the truss spacing does not follow the default truss spacing.

#### Truss restraint print strings

Print strings are placed on all truss restraints so it is clear which trusses they should be placed between.

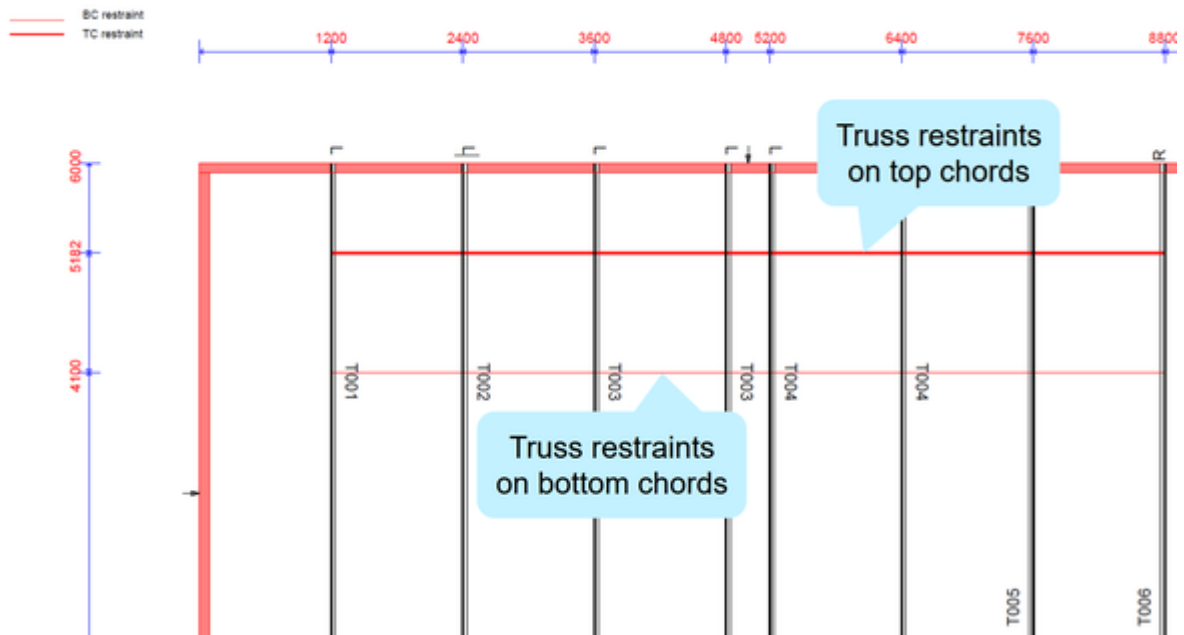
Common truss restraints are printed with truss spacing only, e.g. 900SP

Unique truss restraints are printed with the trusses they span between and the truss spacing, e.g. T001-T002-920SP means the truss spacer spans between trusses T001 and T002, and is 920mm long.

### Truss restraints in layout sheets

Rows of truss restraints are shown in layout sheets.

Top and bottom chord truss restraints rows are indicated by different line weights. Top chord truss restraints are indicated on layout drawings with a solid line, while bottom chord truss restraints have dotted lines.



Use of unique or common truss restraints can be identified from layout sheets according to these rules:

1. Common truss restraints are used where:
  - a. The space between adjacent trusses or truss and wall matches the truss spacing setting in the Roof Construction menu
  - b. AND either
    - i. Adjacent truss chords are facing the same direction
    - ii. Or the truss is next to a wall
2. Unique truss restraints are used everywhere else.

### Truss restraints in truss fabrication sheets

Wherever possible, truss restraints are identified in truss fabrication sheets. They are fixed on the open side (toe side) of the trusses which is the opposite side to the truss webs so that they can be folded out on site and connected to the adjacent truss.

Arrows indicate the approximate location of truss restraints (truss restraints may need to be moved later to avoid clashing with truss webs).

smart: YES flush: NO  
restraint: refer to layout

LEFT ← RIGHT

ANALYSIS		QTY
Status	PASS	2
Approved BY		

Check: (Mark Connections)    Connection type (Weld/ Bolted)    Chord depth (Web/ Flange to web)    Total number of members (Total number of members including any members that are not used)

040 | 3    SC-HEEL | A-75-10-6

Part:    Total no. members at each end of the web    End-to-end (E)    Connection detail (Weld/ Bolted)    Change (Add/ Remove)

Connection Table	
A HEEL	SC-HEEL-G-90-75-9
B APEX	SC-APEX-E1-90-75-10

Chords placed flange-DOWN, Webs placed flange-UP.  
Min screws per conn: 2 (Screw locations diagrammatic only. Refer connection sheet for details.)

PARTS LIST (per truss)					ASSEMBLY DETAILS					TRUSS DETAILS					
DESCRIPTION	No.	LEN	MAT	QTY	DESCRIPTION	No.	LEN	MAT	QTY	APEX HEIGHT	LEFT PITCH	RIGHT PITCH	UNCROPPED LENGTH	UNCROPPED HEIGHT	WEIGHT
CX075ra	001	6061.9	0.75	1	CX075ra	080	937.2	0.75	1	1319	22.5 deg	22.5 deg	6093	1346	25.3
CX075ra	002	3300.9	0.75	1	CX075ra	090	645.3	0.75	1	Precamber = 1.0 mm					
CX075ra	003	3300.9	0.75	1	CX075ra	100	630.3	0.75	1						
CX075ra	004	319	0.75	1	TRUSS TITE				23	FABRICATOR:    CLIENT REF:    CUSTOMER:					
CX075ra	019	630.3	0.75	1	SCREW-12-14x20-HEX				77						
CX075ra	020	645.3	0.75	1	UNTEL-200x35x1.5-260				2	DETAILER:    DETAILED:    SCALE:    JOB NUMBER:    TRUSS:					
CX075ra	030	937.2	0.75	1	UN04475G550	1230	0.75	4							
CX075ra	040	986.5	0.75	1	UN04475G550	430	0.75	4	1	watsk    30-07-2019    1.35    Machine Type    ENDUROTRUSS					
CX075ra	050	1272.9	0.75	1					1						
CX075ra	060	1272.9	0.75	1					1	Page 1 of 1					
CX075ra	070	986.5	0.75	1					1						

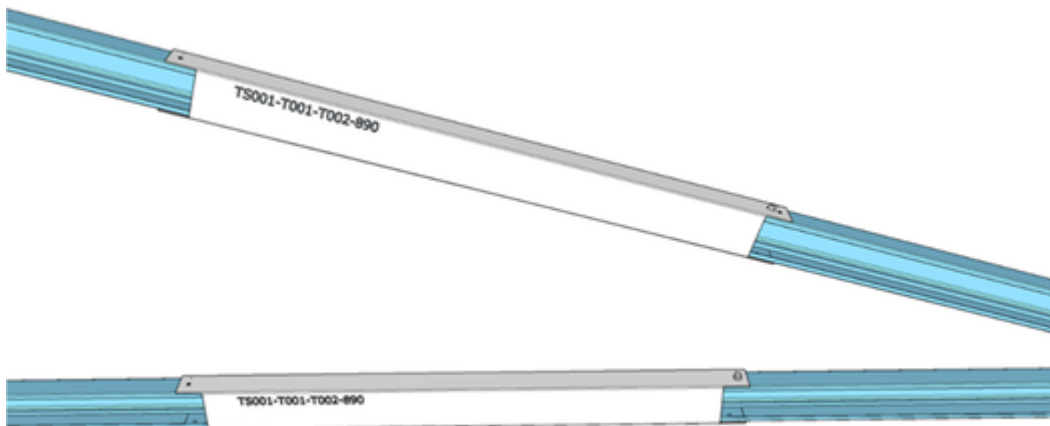
10:00:08 TRUSS: T003-20-07-2019-12:50:02 TrussMaker Vm 1.2.17 CS-22

Truss restraint label in fabrication sheet	Description
Common	Common truss restraints can be pre-attached to truss.
Unique truss restraint, e. g. T001-T002-920SP	Unique truss restraints can be pre-attached to truss.
Refer to layout	This indicates that that there are more than one of these trusses with different truss restraints OR different truss restraints are attached to the same truss.  Refer to layout sheet to identify truss restraints to be attached to each truss, or leave truss restraints to be attached on site.
None	No truss restraints are used.

### 7.9.2 Attaching truss restraints to trusses in factory

Truss restraints can be pre-attached to trusses in factory, folded flat over the truss chord, ready to fold out onsite.

Attach truss restraints to the open side (toe side) of the truss chord in the location shown on the truss fabrication sheet.



**Figure 7.77: Truss restraints pre-attached to trusses in factory**

**7.9.3 Installing truss restraints on site**

To install truss restraints on site:

1. Stand trusses

**Note**

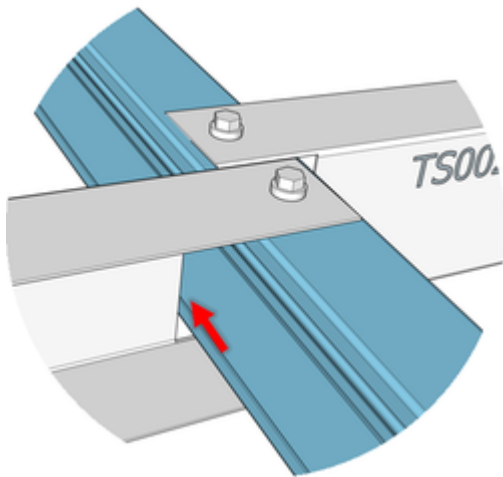
**Note:** Truss restraints should not be used to space out trusses. Truss location should be measured.

2. If truss restraint was pre-attached to truss in factory, fold out truss restraint. Otherwise, position truss restraint between trusses according to layout sheet.

**Note**

**Note:** You need to manually re-position truss restraints where they clash with truss webs.

3. Fasten truss restraint flange to truss chords (or wall top plate) using a 12-14X20 screw at each end of the truss restraint. You may also use M6-1Px18 tek screws. Leave clearance between the truss restraint web and the truss chord.



**Figure 7.78: Fixing detail for U section truss restraint**

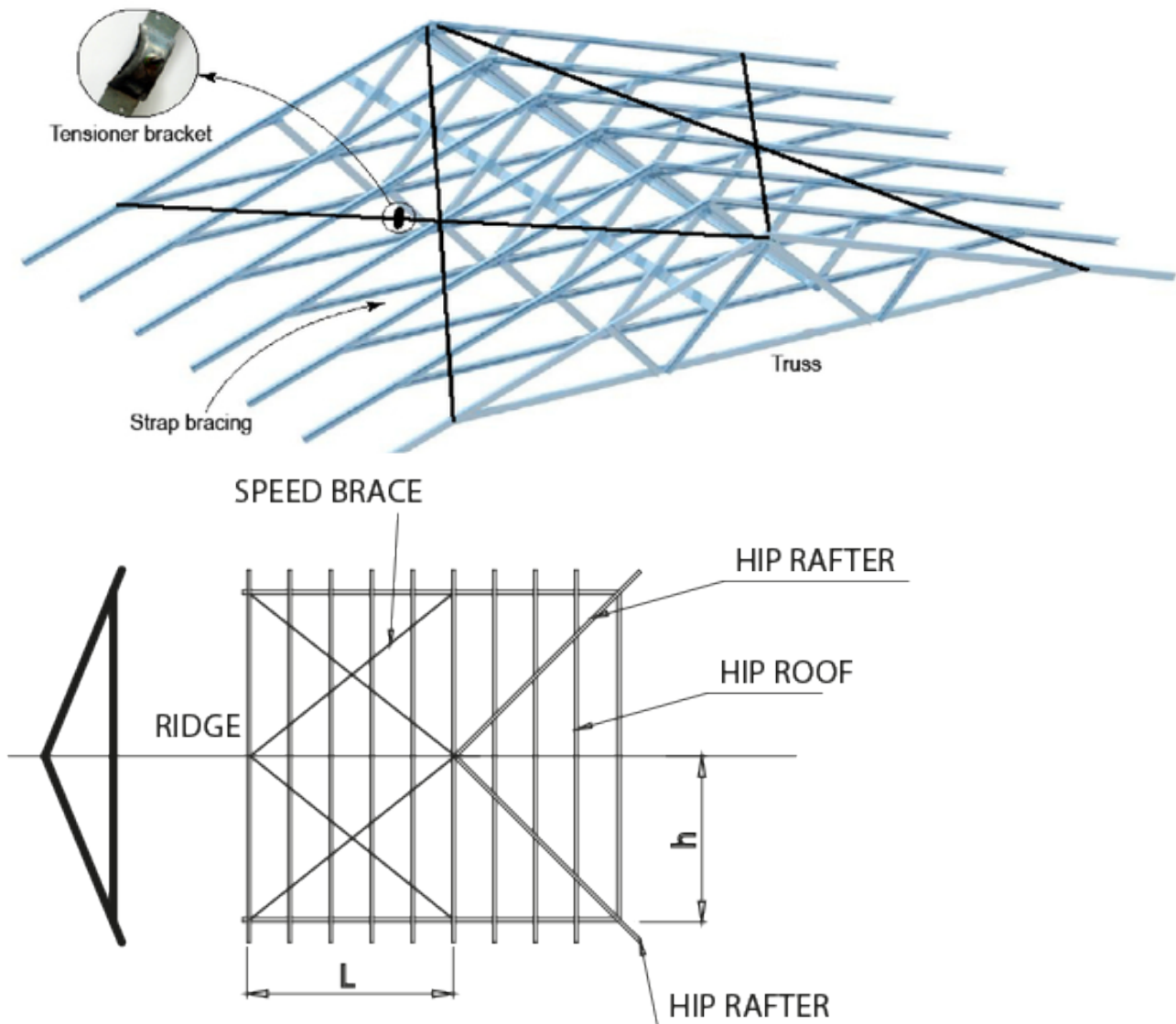
4. Repeat steps for the remaining truss restraints.

## 7.10 Roof bracing

Roof bracing can be broadly classified into four groups:

1. Temporary bracing for installed top chord
2. Roof cross bracing
3. Bottom chord bracing
4. Web bracing.

An example of roof cross bracing is shown in **Figure 7.88**.



**Figure. 7.79: Roof cross bracing using strap bracing**

### 7.10.1 Temporary bracing

Temporary bracing should be in place to support trusses until all bracing is installed. Temporary ties should be made in accordance with **Table 7.9.1**. Ties should be fixed to each truss with a minimum of one #12-14x20 screw.

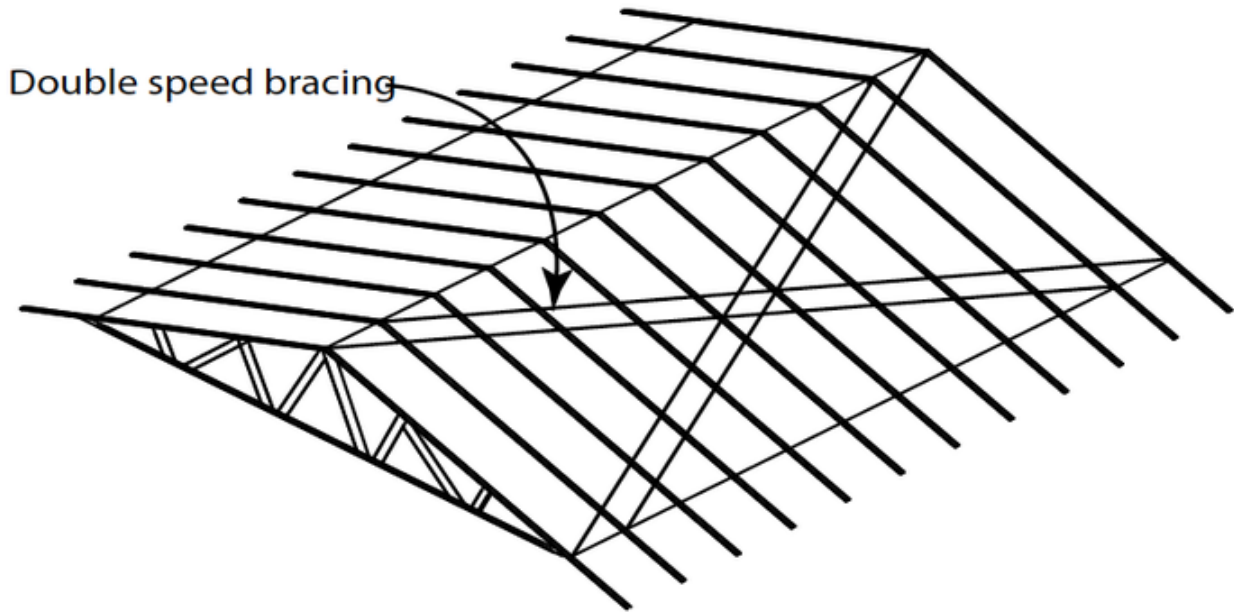
**Warning:** Steelbrace is not acceptable for temporary bracing.

Temporary braces may be truss or batten sections. Minimum sizes are shown in **Table 7.9.1** below. Unless requested, temporary bracing materials are not supplied. Care should be taken that supplied parts used as temporary bracing are removed after permanent bracing is installed for use in their intended location.



**Table 7.10.1 Size of temporary ties**

Truss spacing	To Top Chord	To Bottom Chord
Up to 1200	TOPSPAN@40 x 0.55/ C7555 / C9055 @ maximum 3m spacings	@22 x 0.42/ C7555 / C9055 @ maximum 3m spacings



**Figure 7.80 Double speed brace**

**7.10.2 Cross Bracing**

Speed strap brace must be a minimum 32 x 1.2mm (min.) with minimum tension capacity of 8.4 kN. Bracing may be larger and may have a bend to make installation easier by keeping the bracing straight without any sagging. Proprietary bracing system may be used conforming to AS 4440:2004. Where single speed brace is insufficient, double speed brace needs to be provided as shown in **Figure 7.80**. Refer to the table below for single or double speed brace. Strap bracing with tensioners is another form of cross bracing.

**7.10.2.1 Fixings**

Bracing should be fixed to apex of A-truss as shown in **Figure 7.82**. Bracing should be fixed to wall top plate adjacent to truss positions as shown in **Figure 7.83**. Fix bracing to each intermediate truss using 1 x 12-14x20 hex head screws as shown in **Figure 7.81**. For cantilevered trusses and cut-off/half trusses, bracing should be fixed as shown in **Figure 7.85**.

**Step 1: Apex fixing** Fasten the brace to the outside edge of the top chord of the gable end truss at the apex and lay it diagonally down the slope, at an angle 30° - 45° to the truss line.

**Step 2: Wall fixing** Fix the other end to the outer flange of the top wall plate. Ensure that the trusses are plumb.

**Step 3: Tensioning** When all the braces have been installed, check that trusses are plumb and straight, and are effectively tied together with temporary battens. Where strap brace is used, fix bracing to the apex of the first truss and at the wall adjacent to the last truss as shown in **Figure 7.79**. Tension bracing before fixing to intermediate trusses with tensioner bracket and fix strap to each truss. Fix braces to the upper face of the top chord at each intersection.

**Figure 7.81: Brace to chord connection**

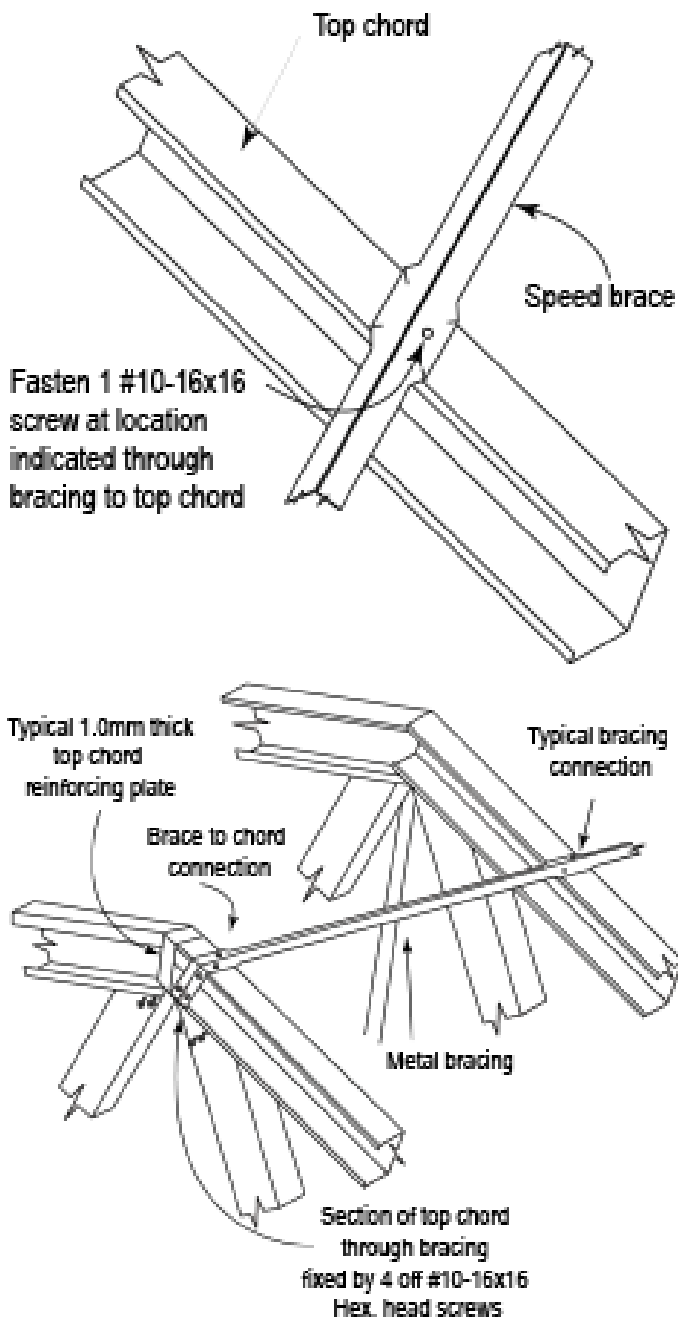


Figure 7.82: End fixing at apex

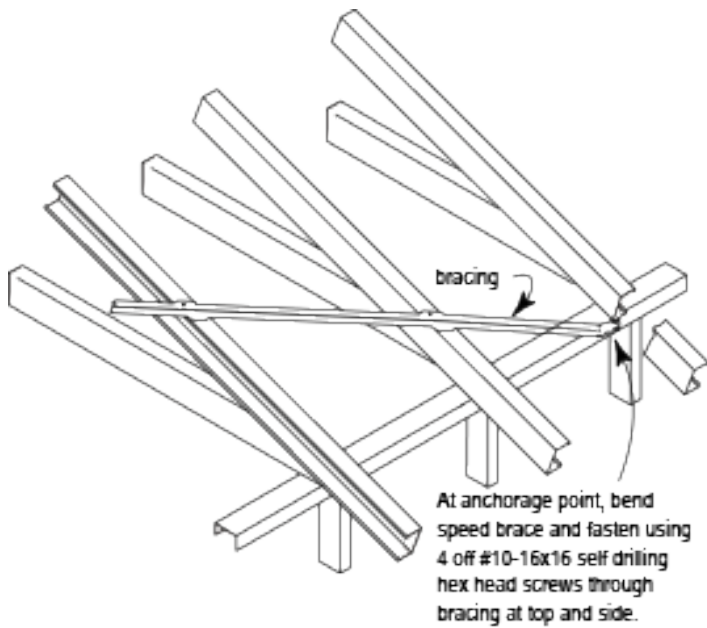


Figure 7.83: Fixing at anchorage point at wall top plate

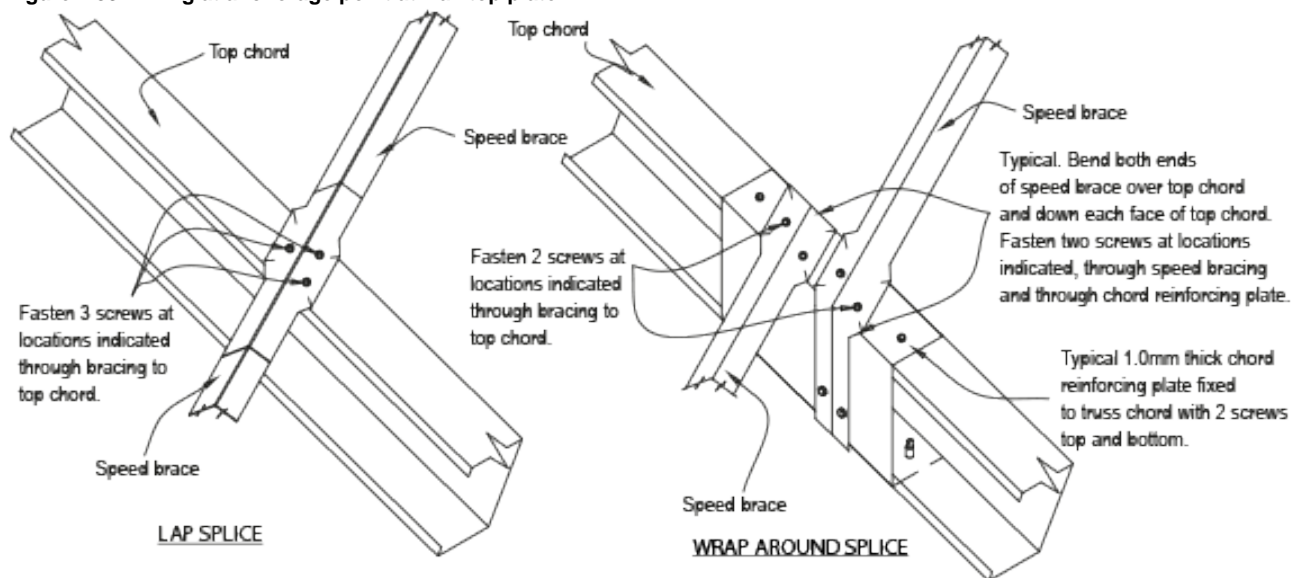
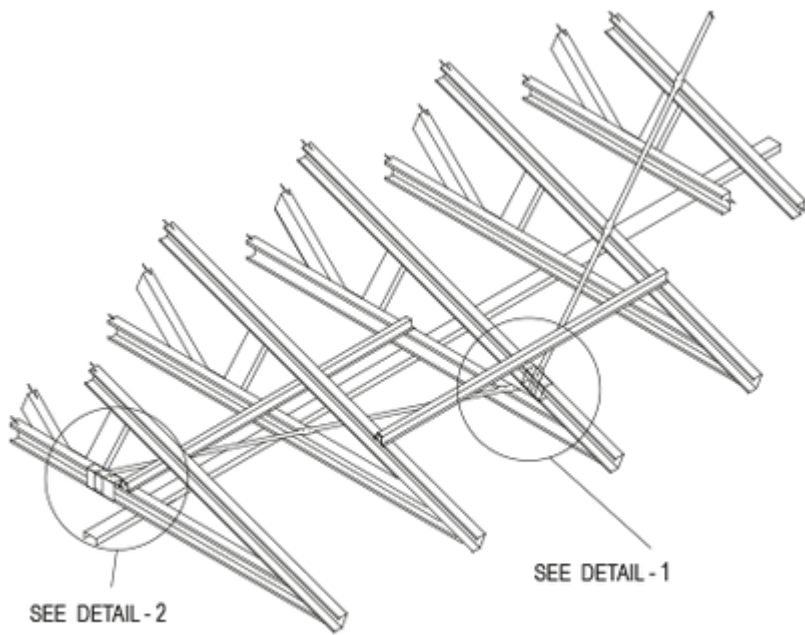


Figure 7.84: Typical splice detail



Locate and fold down speed strap bracing to vertical face of bottom chord of truss. Fasten speed bracing to vertical face of bottom chord with 4 screws.

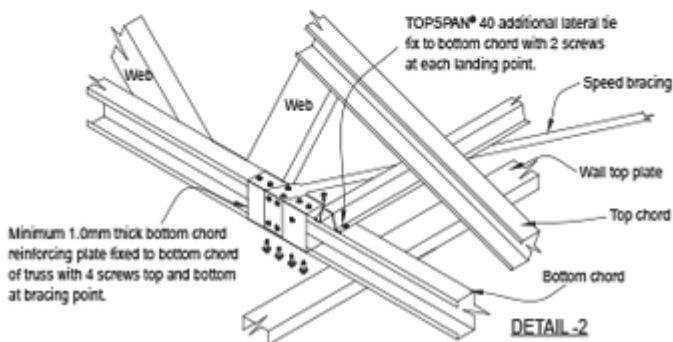
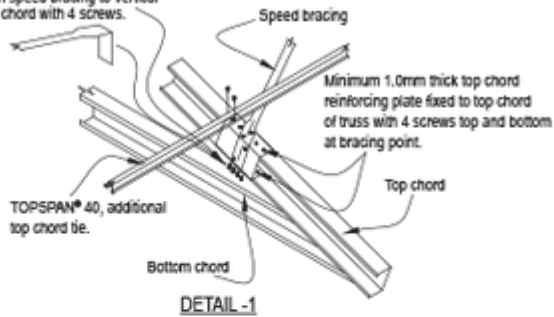


Figure 7.85: Fixing details for cantilevers

## Vertical truss chord

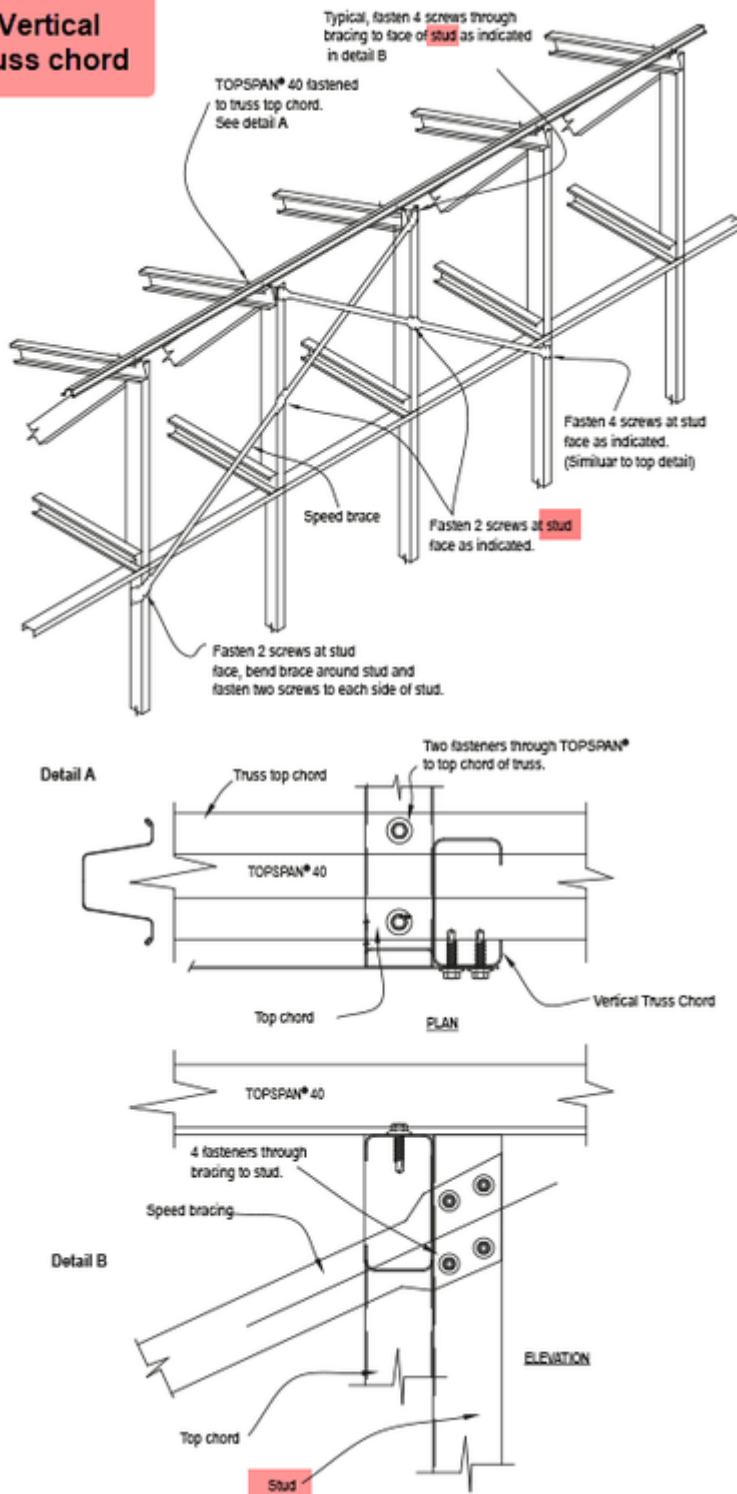


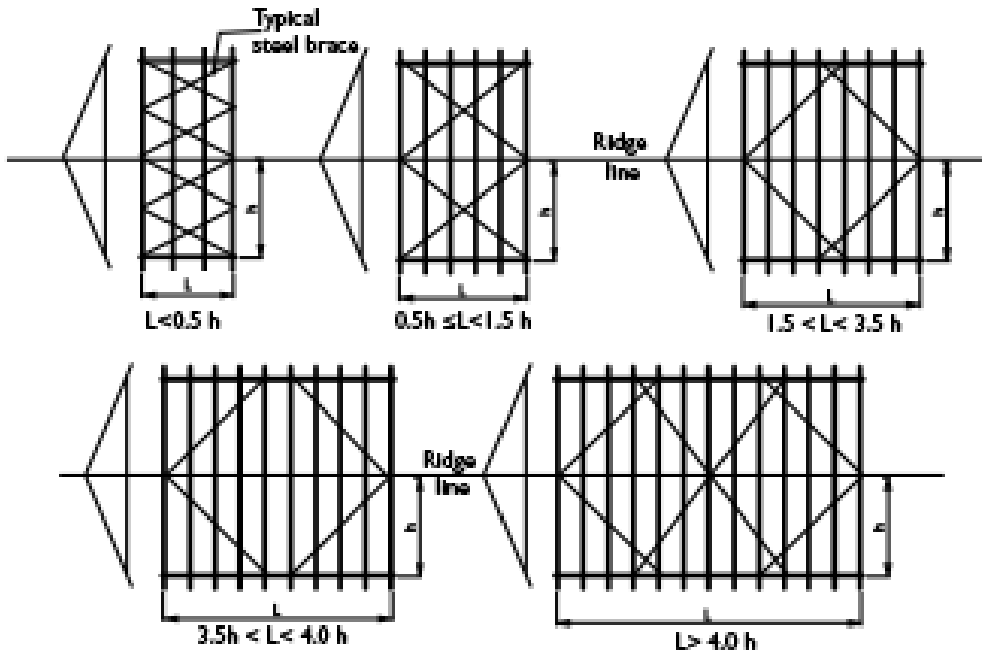
Figure 7.86: Fixing details for cut off or half trusses

### 7.10.2.2 Bracing Layout

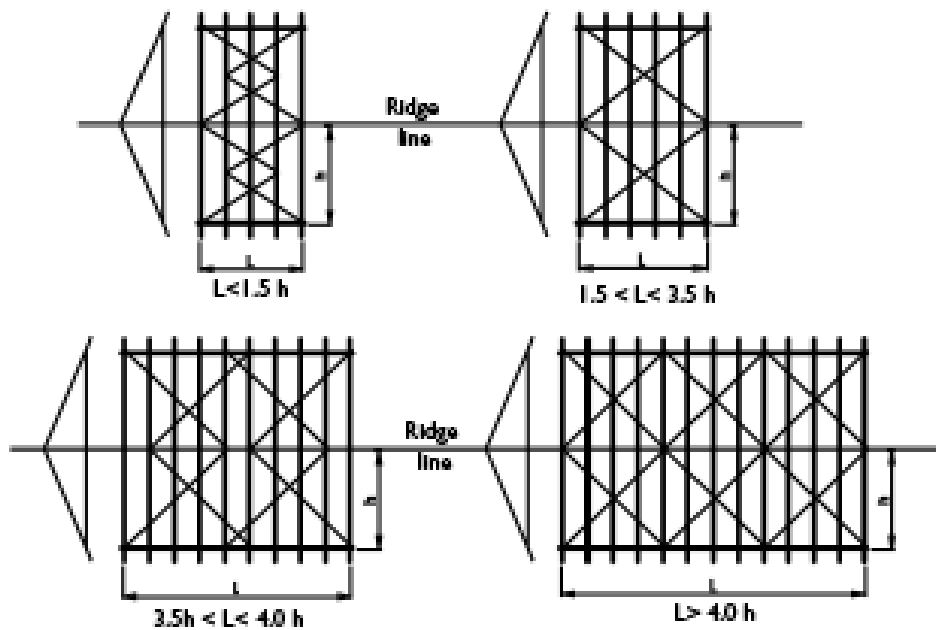
The type and layout of the top chord steel brace are related to the truss span, shape and loading of the roof. The area of the standard truss overhangs is not required to be braced.

### 7.10.2.3 Gable roof bracing layout

## Truss Spans up to 8m



## Truss Spans over 8m and up to 13m



Choose the appropriate bracing pattern based on the size and shape of the roof.

Figure 7.87: Truss Spans 8 to 13m

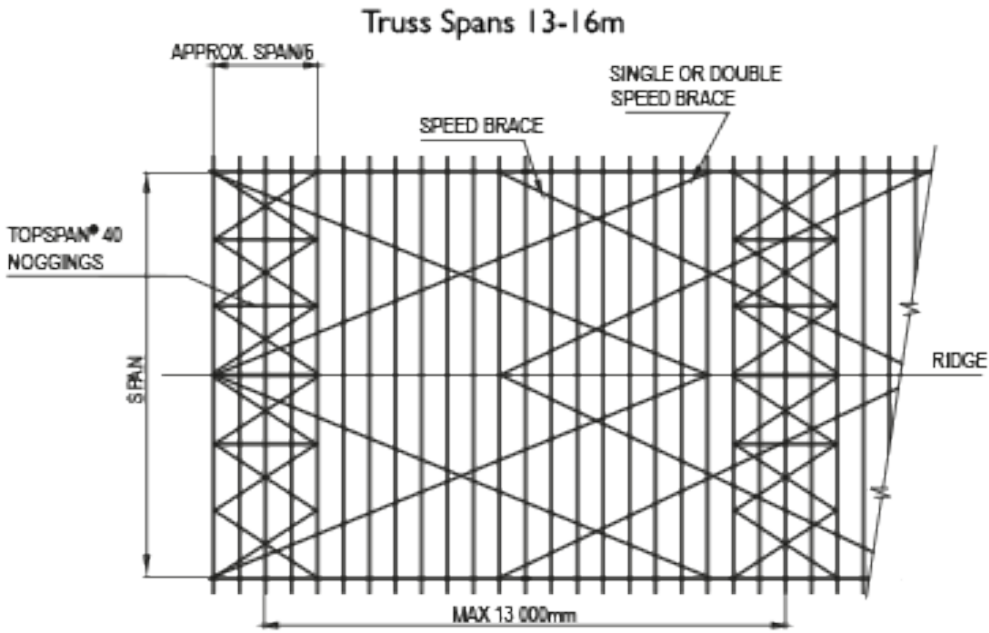


Figure 7.88: Truss Spans 13 - 16m

7.10.2.4 Hip Roof

For roofs with hip zone, the hip rafter serves as bracing and no additional top chord bracing is required in this zone.

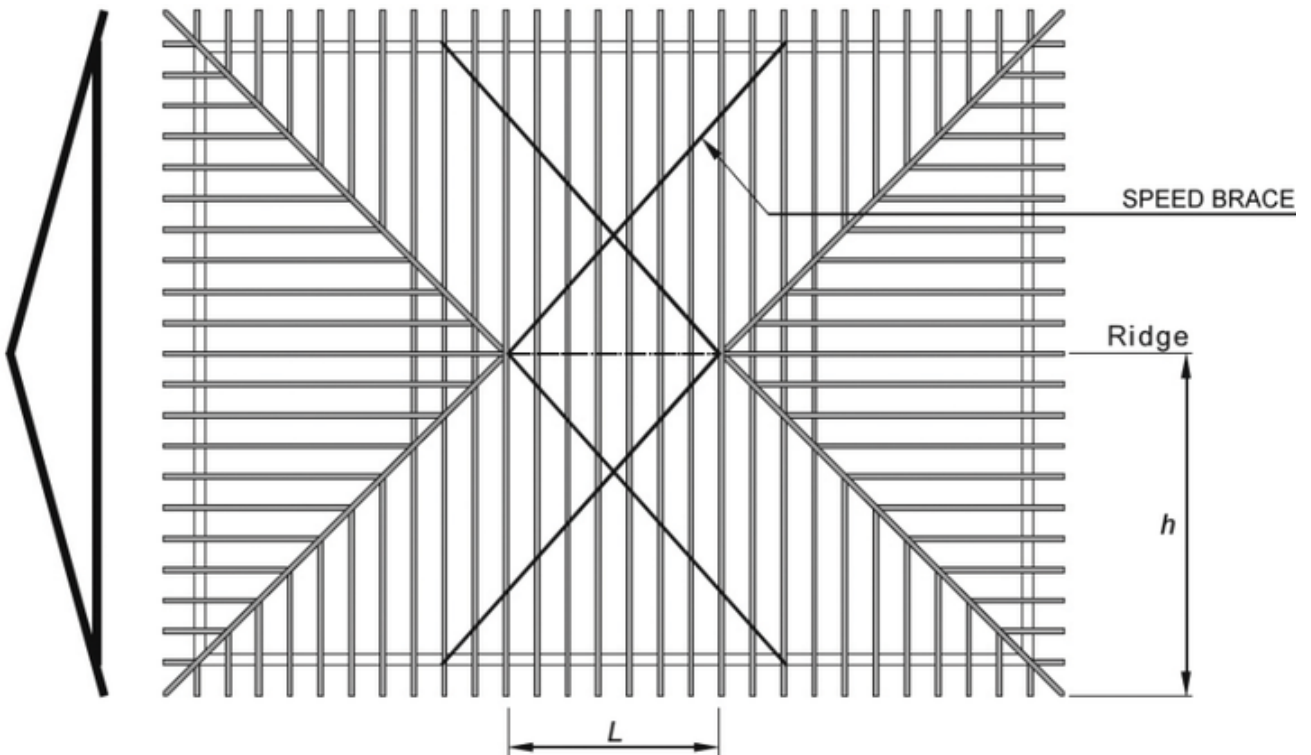
If the portion of the roof between the hip end or Dutch-hip ends ( $L$ ) is greater than half span of roof truss ( $h$ ), then the roof shall be braced as per gable roof.

Roof length  $L >$  half-span of roof truss,  $h$ .

Figure 7.89: Roof length  $L >$  half-span of roof truss,  $h$

Truss Spans up to 8m Truss Spans over 8m and up to 13m Ridge

Figure 7.90: Roof length  $L <$  half-span of roof truss,  $h$





**7.10.2.5 Dual Pitched Roof** On dual-pitched or cut-off roofs where the ridge line is not central on the building, each side of the ridge shall be considered as a separate case and gable end details shall be applied.

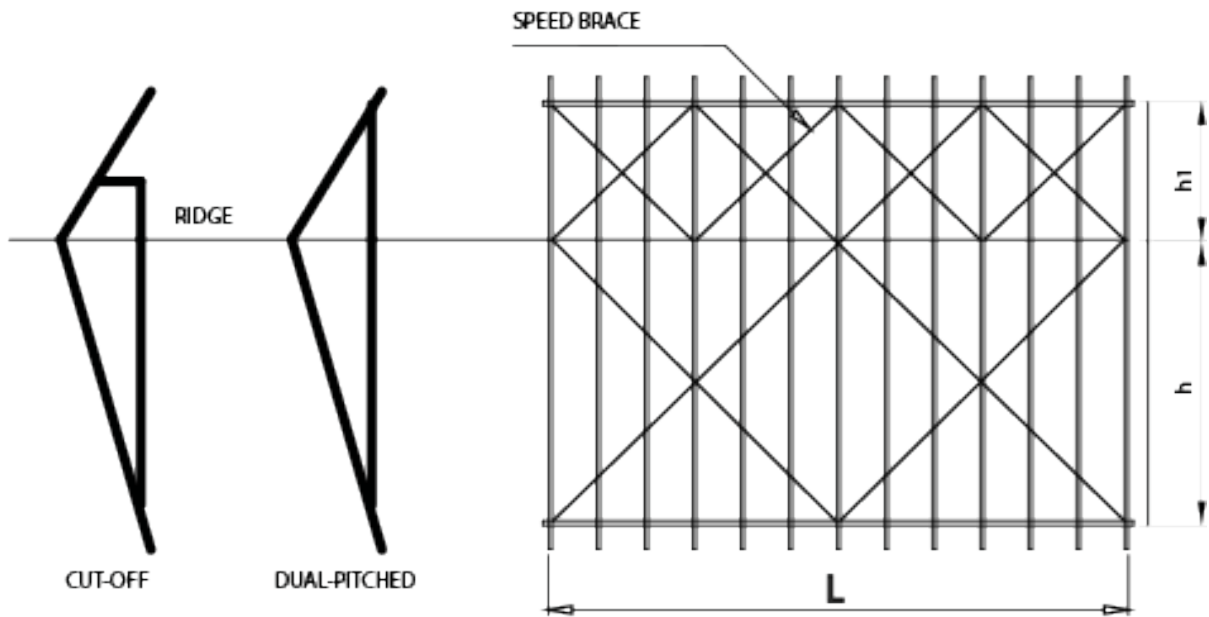
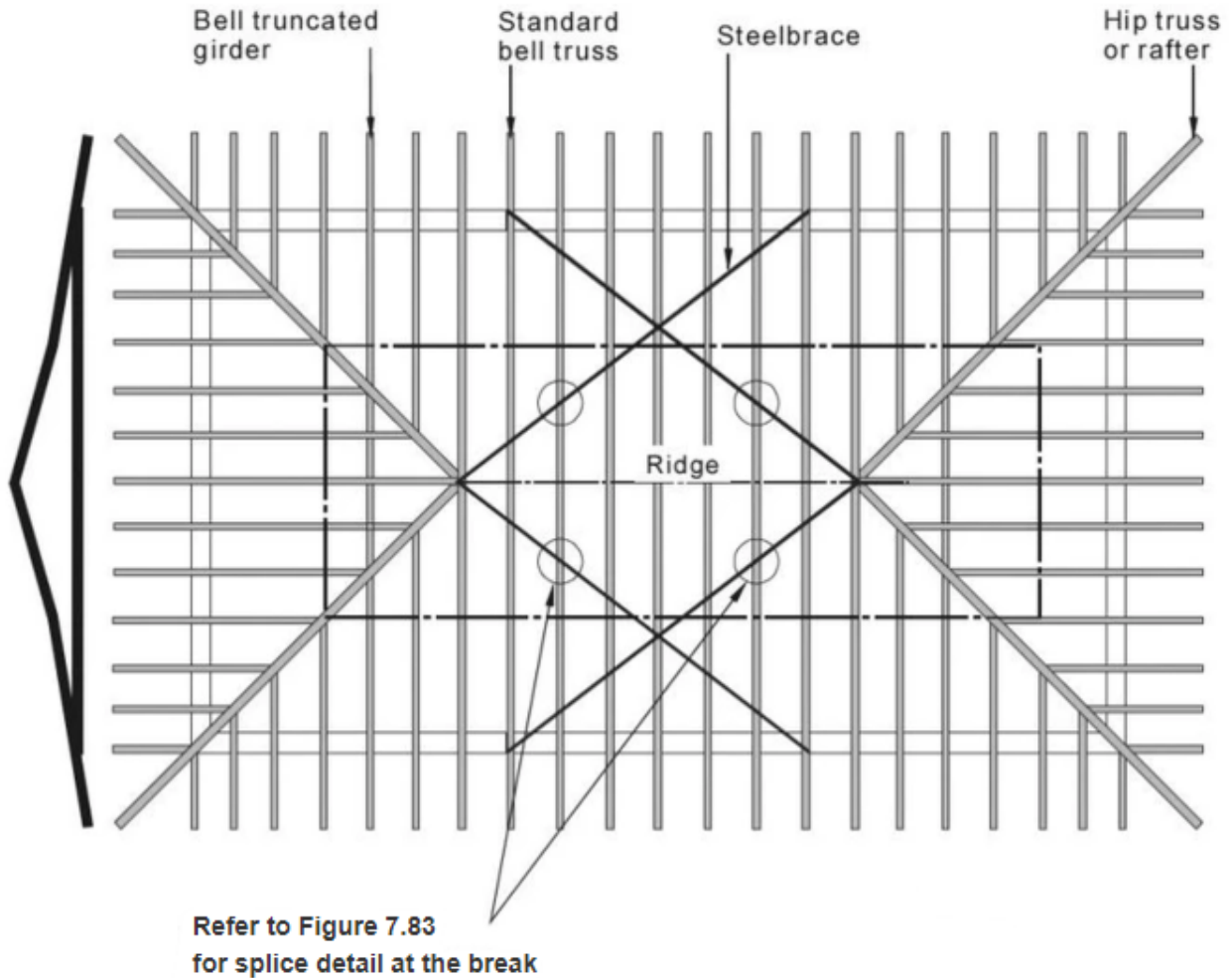


Figure 7.100

### 7.10.2.6 Bell Roof

For bell trusses, the speed brace should be spliced at the bell breaks as shown below.

Refer to **Figure 7.84** for typical steel brace splice detail.



**Figure 7.101: Bell roof cross bracing**

### 7.10.3 Bottom chord bracing

Bottom chord bracing is required to provide restraint to bottom chords of trusses when they are in compression due to wind uplift. Where ceiling battens are mechanically fixed to the bottom chord of trusses, using screw fasteners the ceiling battens (along with ceiling sheeting) provide adequate bottom chord bracing.

For suspended ceilings, clip-on battens or exposed bottom chords where ceiling battens do not provide lateral restraint, bottom chord ties shall be provided.

Bottom Chord bracing consists of bottom chord ties and diagonal bracing.

Bottom chord ties may be roof battens or truss chord material (Minimum TOPSPAN® 22) fixed to each at spacing specified by roof designer and used in the truss design. The diagonal bracing may be minimum 32 x 1.2 strap brace fixed at each end in accordance with the bracing layout, tensioned and then fixed to each intermediate truss bottom chord. Refer to **Figures 7.90** and **7.92** for details and numbers of screws.

Ties and bracing to be fixed to supporting walls to transfer bracing loads to the structure.

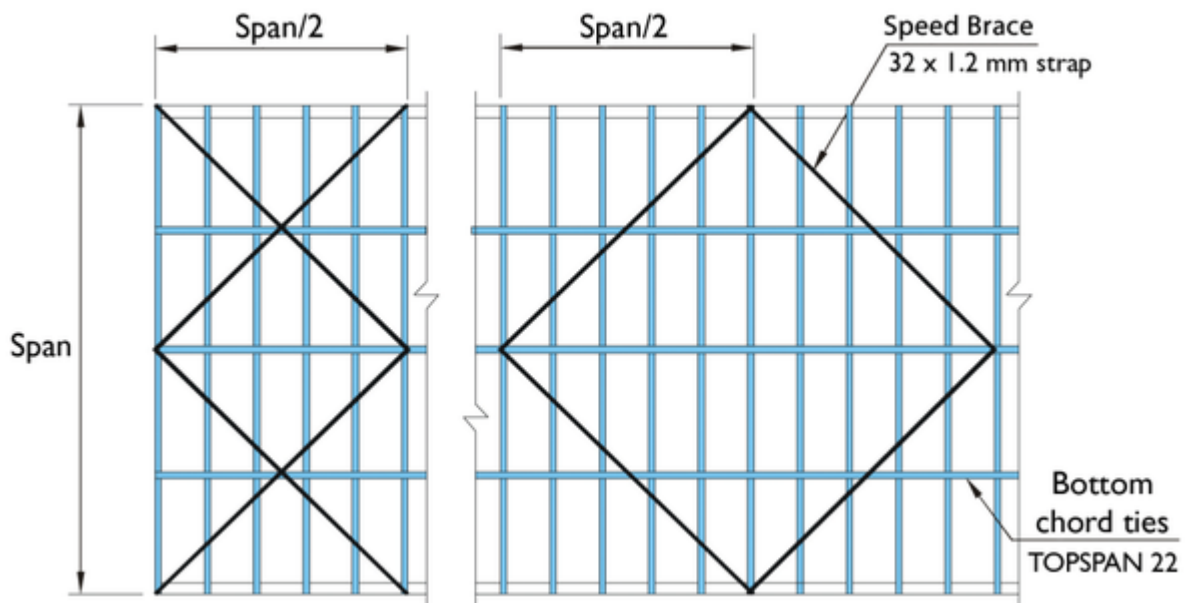
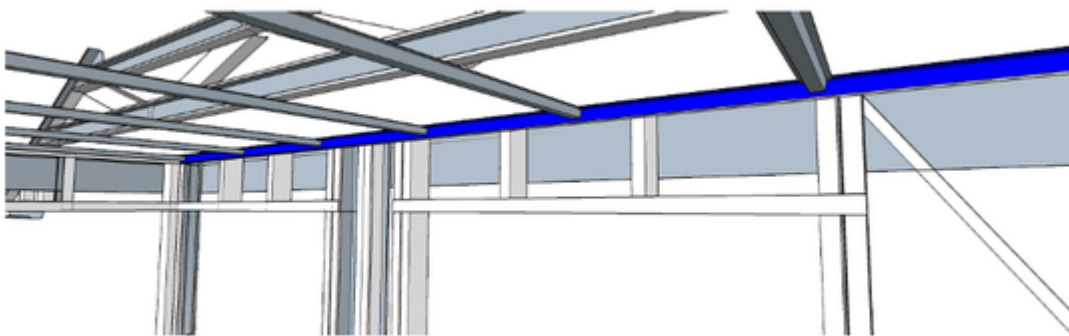


Figure 7.102: Typical bottom chord ties bracing layout

The ends of ceiling battens restraining bottom chords shall be connected to end walls via a trim angle. Refer to Figure 7.103.



Ceiling battens restrained to end walls via trim angle. Connect ceiling batten to min. 35x35x1mm trim angle via 2 x 12-14x20 hex head self tapping fasteners. Ceiling battens may also be fixed to the bottom chords of trusses that are restrained horizontally in Type 1A or Type 2 Hip ends.

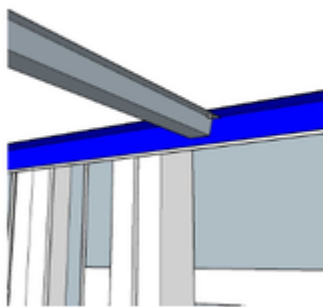


Figure 7.103 Ceiling battens restrained at each end

#### 7.10.4 Bracing Trusses with Raking or Coffered Ceilings

Additional top and bottom chord bracing and restraints required where coffered or raked ceilings are used to ensure that loads are transferred to adjacent walls, and trusses are restrained. Refer to Figures 7.104 and 7.105.

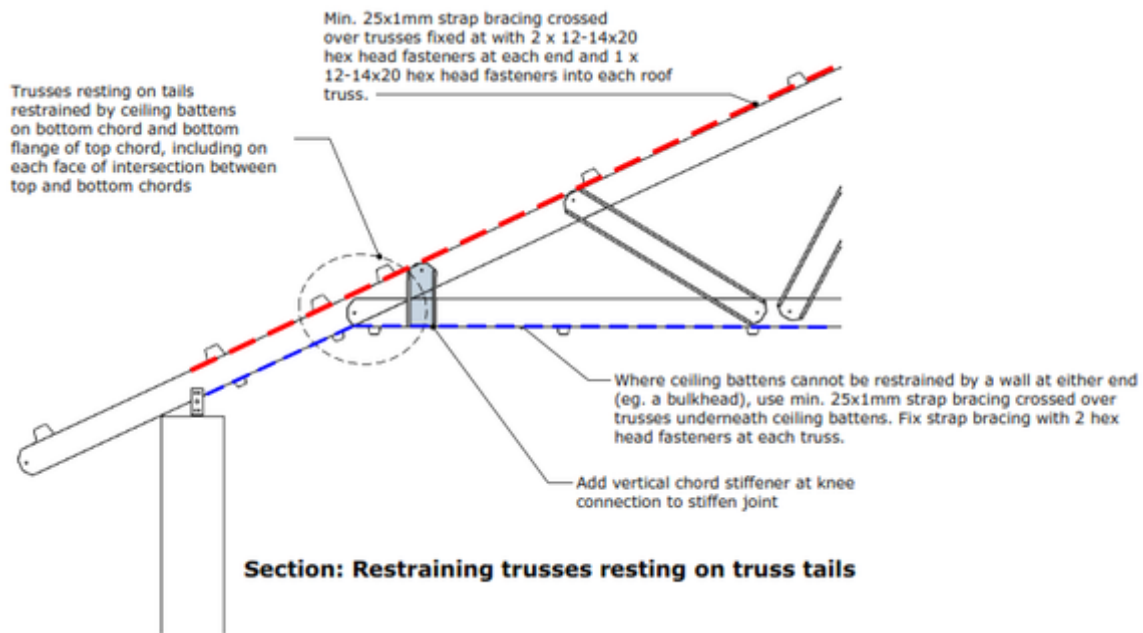


Figure 7.104: Section of bracing and chord restraints in raked ceiling

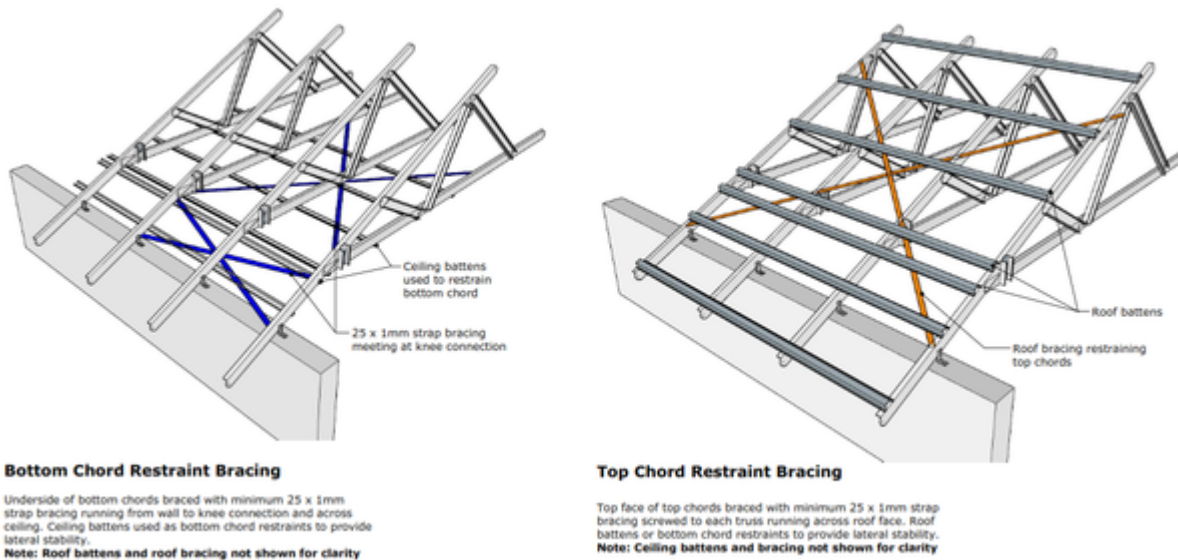


Figure 7.105: Isometric of Top and bottom chord bracing and restraints in raked ceiling

### 7.10.5 Web bracing

The slenderness and capacity of web members of longer lengths can be enhanced by boxing of sections or by providing lateral restraints. The lateral restraint extends out at right angles to the plane of the truss and along the building and is braced back to the ceiling on roof plane at each end of building. **Figure 7.106** shows ties which are suitable for cases when trusses are parallel to each other and webs of trusses line up. A web rail is suitable when trusses are parallel to each other but the webs do not line up, as illustrated in **Figure 7.107**.

Web rails are usually C7510ra or C9010ra channel and the lateral ties are usually specified as TOPSPAN® 40. The Trained Software User will advise if lateral bracing is required. Typical web rail and lateral ties fixing details are shown in **Figure 7.108**.

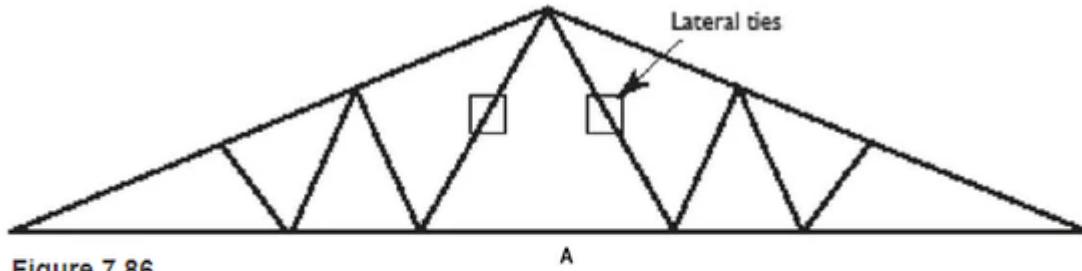


Figure 7.86

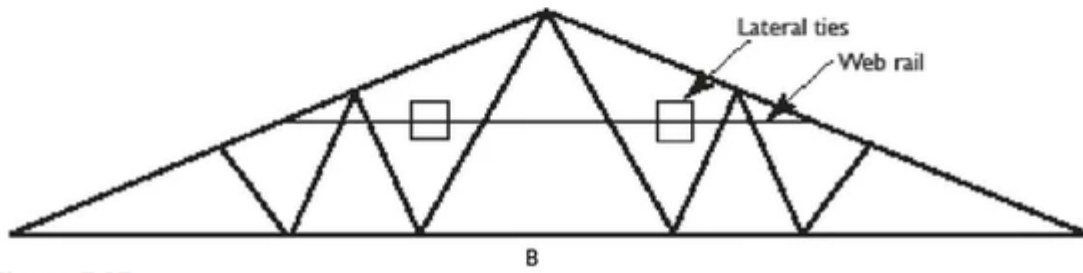


Figure 7.87

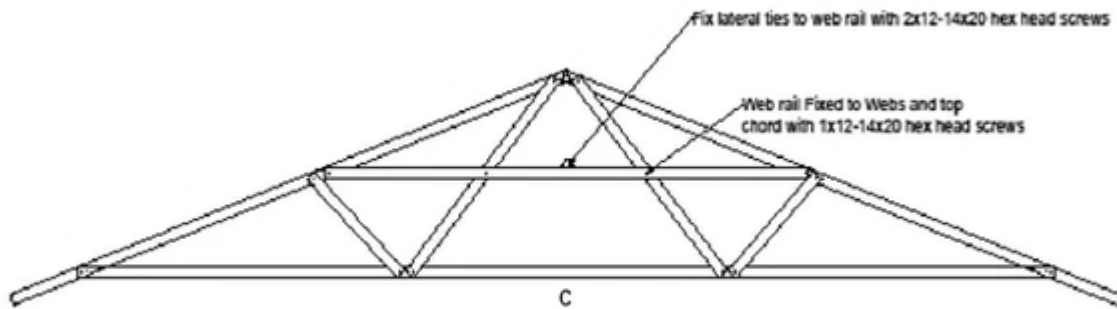


Figure 7.88

## 7.11 Battens

### 7.11.1 Ceiling battens and plasterboard angles

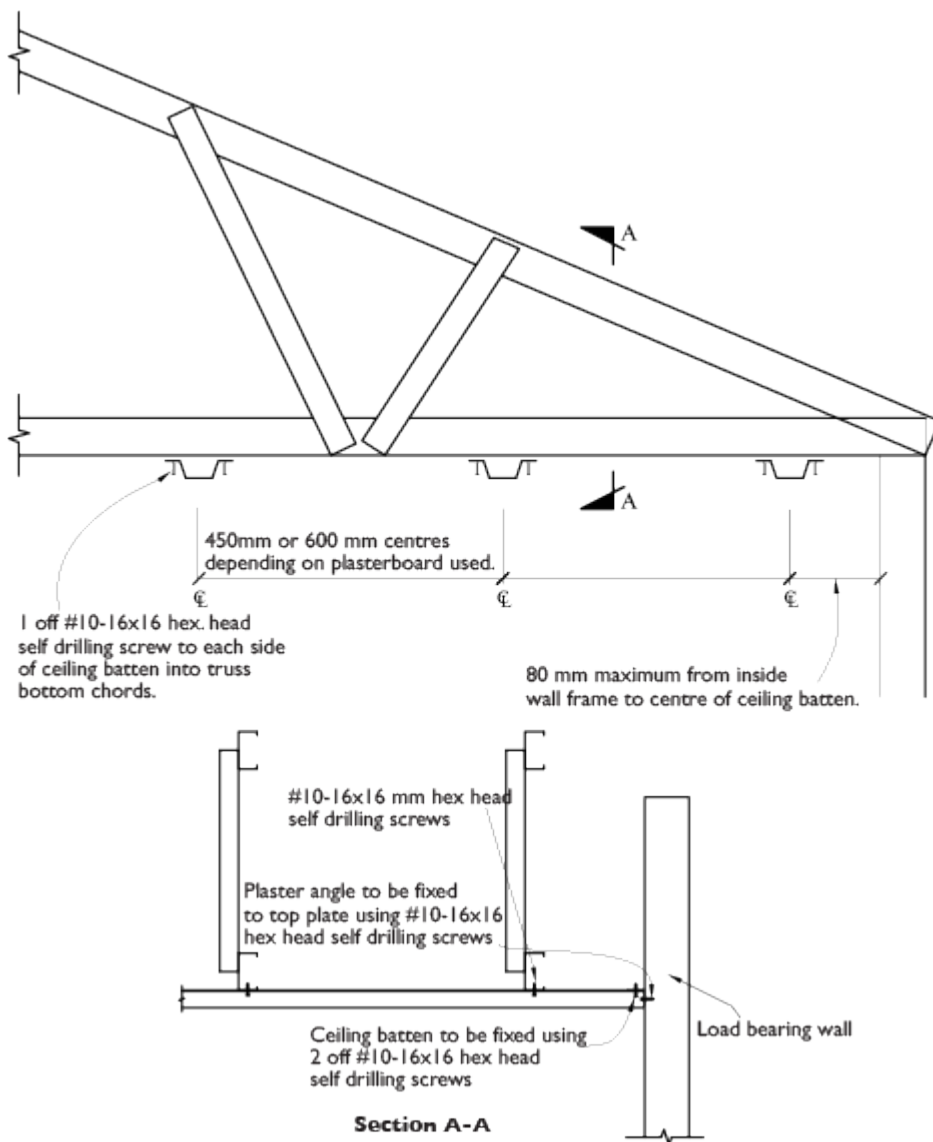
Ceiling battens must be fitted immediately after the roof trusses have been installed. By fixing the ceiling battens at this stage the roof trusses will be laterally restrained without the need of bottom chord ties.

**Step 1:** When all trusses are erected, install ceiling battens to the underside of the bottom chords. Ceiling battens can be spaced at 600mm centres or 450mm centres depending on the type of plasterboard that will be used for the ceiling (check the specifications). Ceiling batten sizes shall be selected from batten manufacturer's technical literature and sized to suit span, spacings and loads.

**Note:** Ceiling battens spacing is dependent on ceiling lining. For suspended ceilings, lateral restraints must be provided at spacings specified by the building designer.

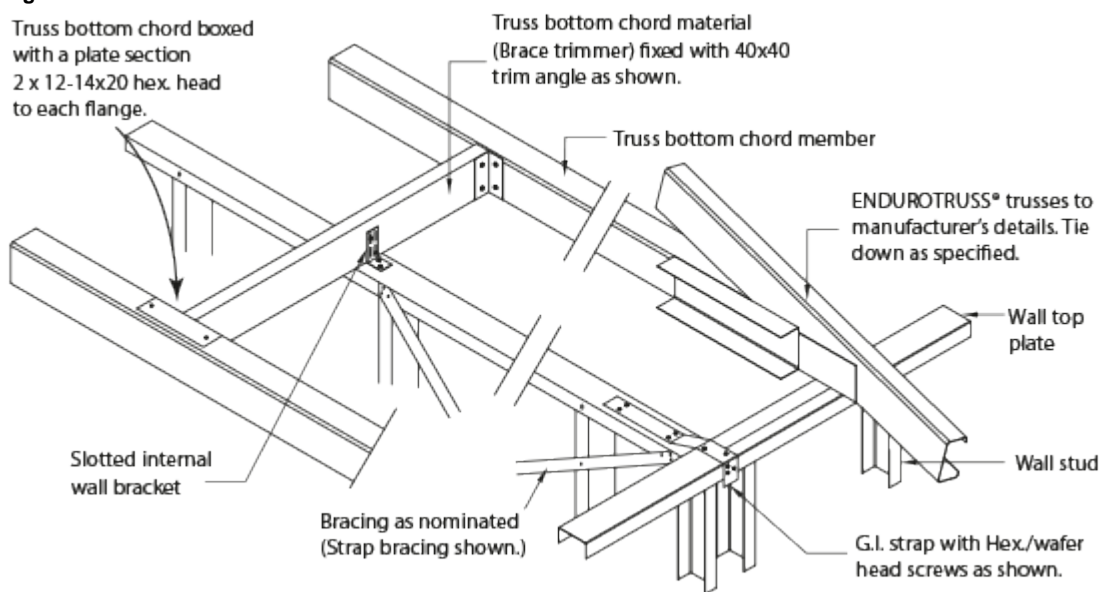
**Step 2:** Fix the ceiling battens with two #10-16x16mm hex head self drilling screws, one into each flange of the batten into the bottom chord of the truss.

**Step 3:** Plasterboard angle must be used at the intersection of the ceiling batten/load bearing wall junction to support the ends of the ceiling battens.



**Figure 7.109**

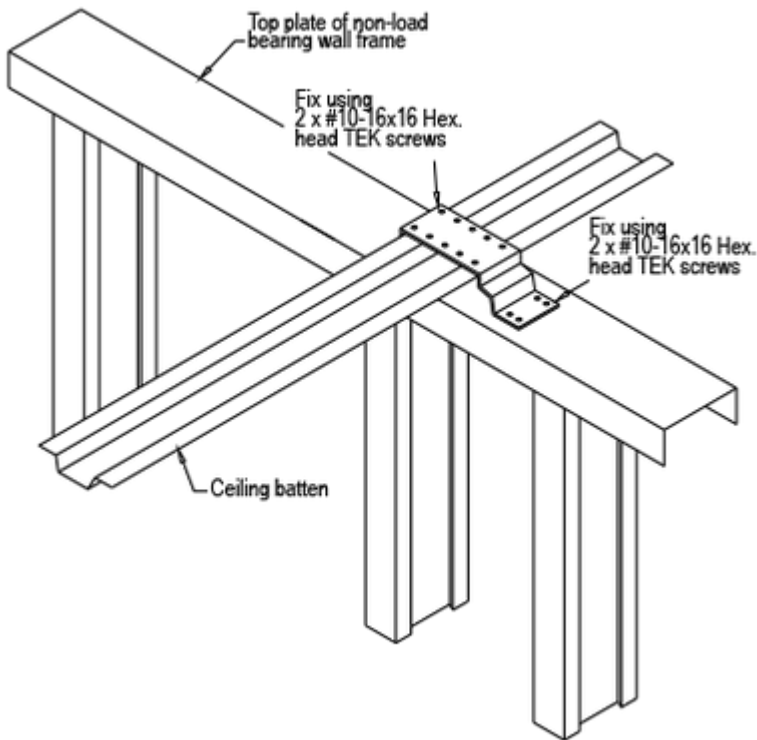
Truss bottom chord boxed with a plate section 2 x 12-14x20 hex. head to each flange.



### 7.11.2 Internal wall support and shear transfer

**Figure 7.110: Transfer of Racking Loads to Internal Bracing Walls - Internal Wall Parallel to Trusses**





It is important that the truss can move up and down in this bracket so screws should be able to slide. To enable the trusses to slide ensure the fastener is placed in the middle of the slot and it is not over tightened.

For shear transfer, refer to Wall Installation manual.

**Step 4:** Fix one #10-16x16mm hex head self drilling screw down through the top of the bracket and into the top of the ceiling batten to stop the bracket sliding.

**Step 5:** Bend the bracket down to the top plate of the internal wall and fix two #10-16x16mm hex head self drilling screws through the foot of the bracket into the top plate.

**Refer to Figure 7.109**

**Step 6:** Install hitch brackets to the bottom chord of trusses at a maximum of 1200mm centres. Fix two #10-16x16mm hex head self drilling screws into the side of the flat face of the bottom chord.

**Step 7:** Now fix two #10-16x16mm hex head self drilling screws through the foot of the bracket into the top plate.

**Refer to Figure 7.110**

### 7.11.3 Roof battens and spacings

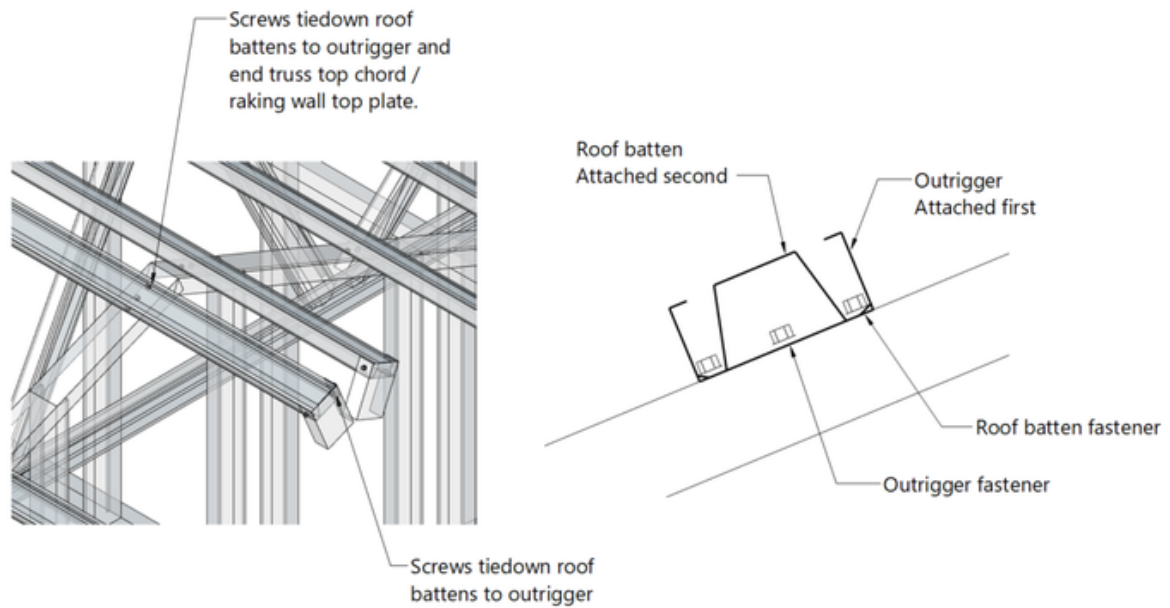
Roof battens are installed to support the roof material and prevent truss top chords from buckling. Before installing roof battens you must consult the ENDUROCADD® output documentation and the technical literature supplied by your chosen roof batten manufacturer to select appropriately-sized roof battens for the span, spacing and loads present in your job, and ensure that the specified roof batten spacings and fixings provide the restraint assumed in the truss design.

**Warning:** Roof bracing is required to resist lateral forces from the roof battens. For information about installing cross bracing, see **Section 7.10.2 Roof cross bracing**.

**Note:** Roof battens must be securely connected to outriggers directly or via barge parts to ensure that roofing uplift is resisted by the outriggers.

Refer to roof cladding and roof batten suppliers for connection methods and capacity requirements.

Roof battens can be placed inside **unboxed 90mm outriggers**. When unboxed 90mm outriggers are used and the Trained Software User has aligned the roof battens and outriggers you will also need to insert the batten into the outrigger C section.



For **unboxed 70 and 75mm outriggers**, roof battens must be next to outriggers and connected to a fascia barge at the end of the verge overhang. Fascia barge may be a boxed ENDUROFRAME C section or other material, refer to Roof batten manufacturer's installation instructions.

Where **boxed** outriggers are used, roof cladding can be directly fixed to the web of the outrigger boxing therefore roof battens are not required in this area.

**Note:** Gable ladders are in line with the roof plane. Roof battens continue from trusses over the gable ladder, and are fixed to the gable ladder.

To install roof battens

**Step 1:** Study the entire set of architectural and fabrication drawings.

**Step 2:** Set out and mark the roof batten positions. You must:

- Ensure roof batten spacing does not exceed the maximum roof batten spacing specified by the ENDUROCADD® Trained Software User and listed on the output documentation
- Check manufacturer tables to ensure battens are correctly spaced.

**Warning:** Batten spacing must not exceed the maximum spacing specified by the Trained Software User.

**Note:** Battens should be spaced at 900mm centres for sheet roofs unless otherwise specified.

**Step 3:** Position the first batten at its marked position.

**Step 4:** Connect the roof batten to each truss by fixing a single #10-16x16mm hex head self-drilling screw through each batten flange at each support:

- truss
- raking wall top plate
- outrigger barge where unboxed 70 and 75mm outriggers are used.
- end of outrigger where roof battens are placed inside unboxed 90mm outriggers.
- gable ladder noggling flange and boxed barge flange

**Warning:** You must fix roof battens to every truss, including each ply of girder truss.

**Note:** For roofing fix a roof batten each side of the line formed from the intersection of the jack rafters and the chords of the truncated trusses to finish the hip roofline. Use two #12-14x20mm hex head self-drilling screws at each intersection.

**Step 5:** Repeat **Steps 3** through **4** for the remaining roof battens.

Installing roof battens is complete.

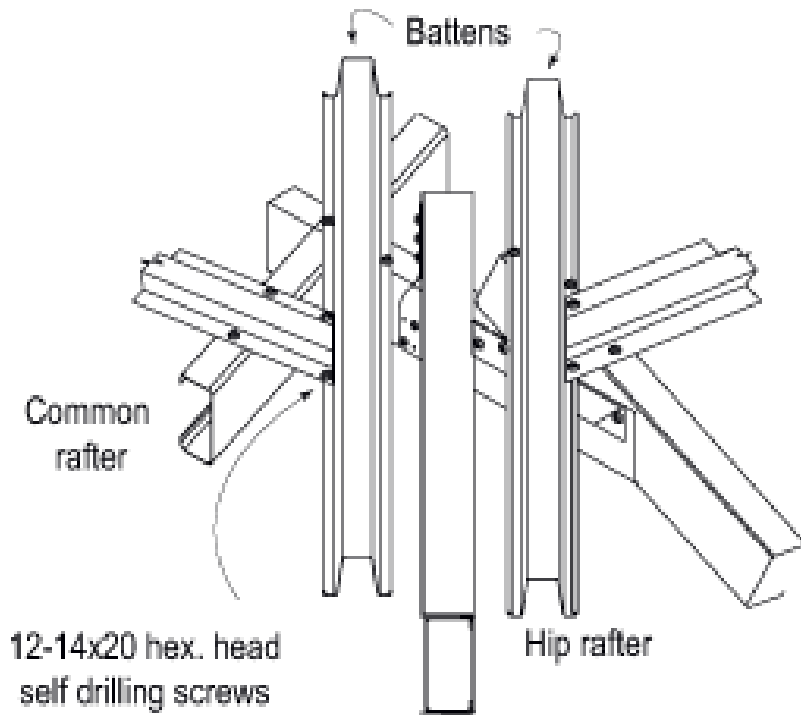


Figure 7.111: Hip rafter and batten arrangement



Figure 7.112: Veed hip rafter batten arrangement

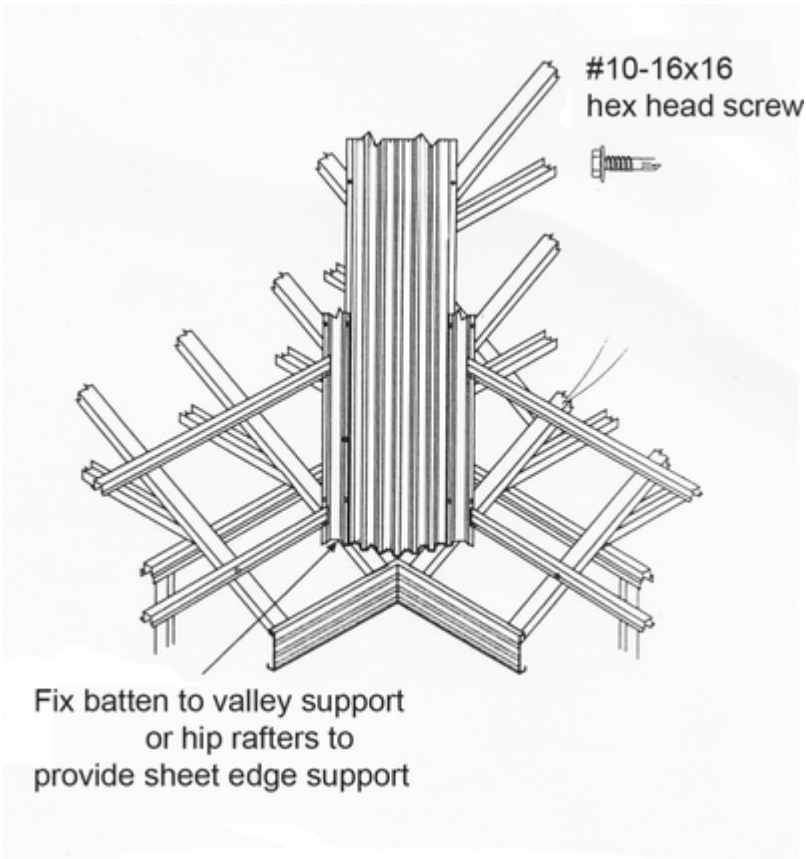
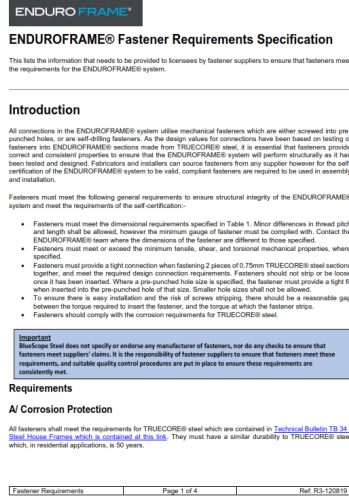


Figure 7.112: Valley gutter arrangement

## 7.12 Fasteners

### Important

Fasteners used in structural applications must comply the ENDUROFRAME® Fastener Requirements specification which is attached.



Refer to the Enduroframe Installation manual website for more information.

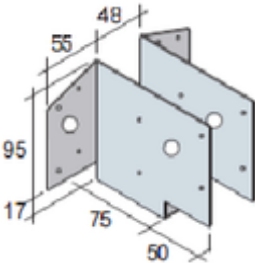
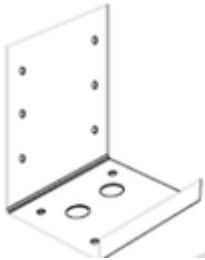
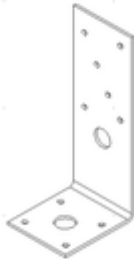
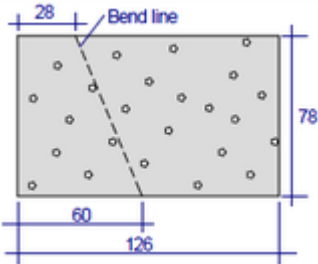
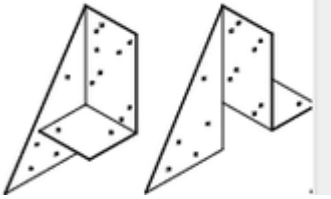
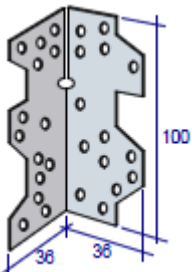
Fasteners used should comply with the mechanical properties specified in the ENDUROFRAME Design Manuals. Please check with the manufacturer of frames or the help portal to confirm fastener suitability.

Picture	Description	Application
	5/16-12 x 17 Hex Washer Trusstite Or 17-15 x 15mm GX screw Trilobular thread form	Primary connection of truss components through pre-punched holes. Both screws listed are suitable for the application.
	#10-16x16 hex head self drilling screw.	Low strength fixing- ceiling batten fix, chord and web boxing. Used in all wall systems
	Wall fastener – M6 x 1P x 15mm Smooth Top GX screw Wall tite (Trilobular thread form)	Connecting wall frame components together through pre-punched holes. Used in ENDUROWALL™ FRAMING SYSTEM,
	#12-14x20 hex head self drilling screws	General Framing Screw- Roof, Wall and Floor frame installation Used as reinforcing in truss manufacture.
	M6,0 x1P x 18,0 Smooth Top Gx Teks	Stiffening stud to plate connections and connecting lintels to plates
	M6.5 – 12 x 42 Hex Head Self Drilling Screw	Connecting smart rafters to truncated truss top chords.

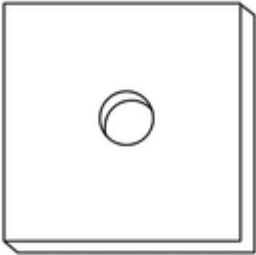
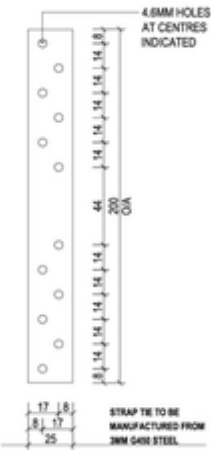
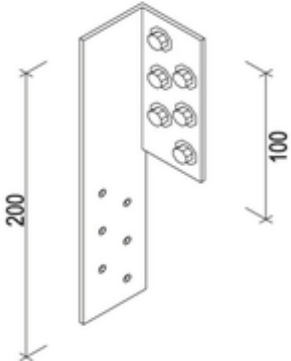
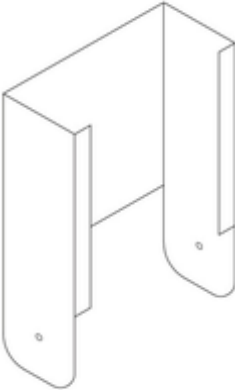
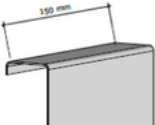


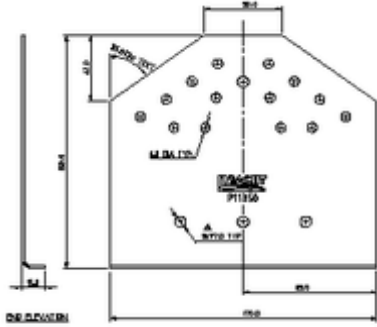
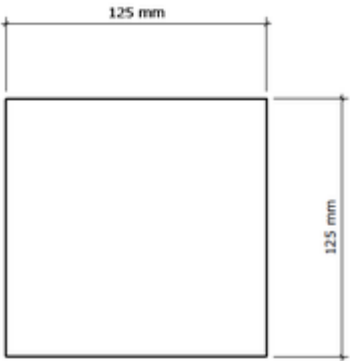
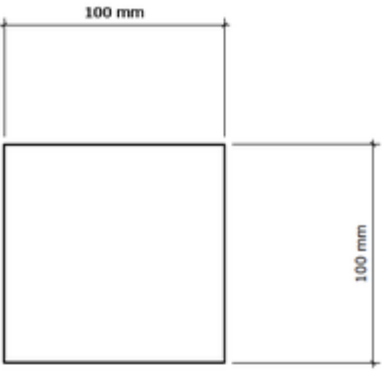
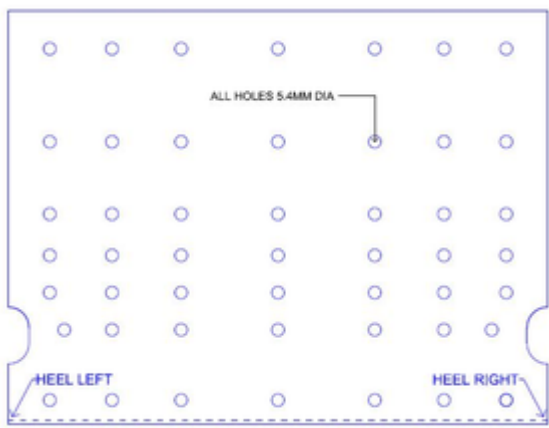

The use of the correct fasteners in the quantities shown in the truss fabrication drawings are essential to ensure the design capacity of the trusses are achieved.

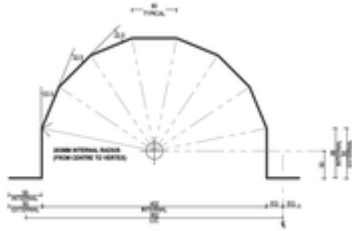
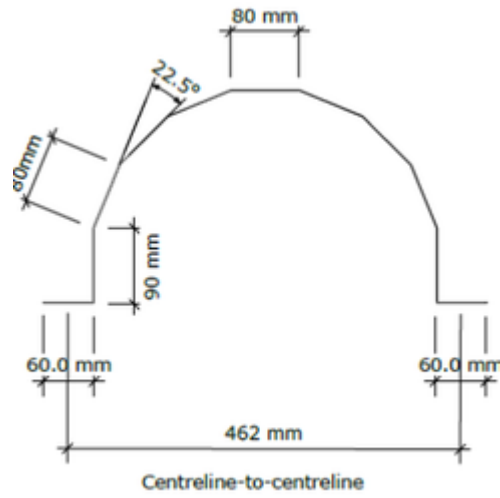
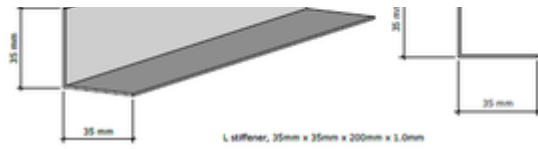
### 7.13 Components

Picture	Description	Application	Supplier
	Bridge Truss Boot TBJ45 1.6 mm B.M.T. Zincform G450 Z275	Bridge Truss Boot	Pryda
	Universal Cleat 70 (Cyclonic Hold-down Bracket) 1.6 mm B.M.T. G450 Z275	Hold down bracket	Lysaght
	CPAH Hold down bracket	Hold down bracket	Pryda
	Hip Mitre Plate	Hip Mitre Plate	Pryda
	Trip-L-Grip Left and Right Hand	Hold down bracket	Pryda
	MultiGrip	Hold down bracket	Pryda

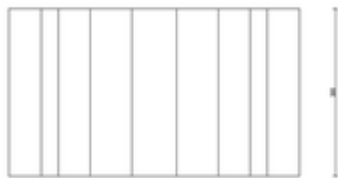


	<p>40 x 40 x 5mm square galvanised Washer</p>	<p>Washer for use with CPAH Bracket</p>	<p>Various</p>
	<p>25 x 3 x 200mm Steel Tie-down Strap</p>	<p>Combination Heel Connection Plate and Tie-down.</p>	
	<p>50 x 50 x 3 x 200mm Notched Equal Angle Tie-down - Right &amp; Left</p>	<p>Combination Heel Connection Plate and Tie-down.</p>	
	<p>Transition Section Connection Manufactured off the ENDURO rollformer</p>	<p>Hold down bracket</p>	<p>Enduro frame</p>
	<p>Apex Zed Stiffener Z10015 150mm long</p>	<p>High Strength Truss Apex</p>	<p>Various</p>

	<p>APEX PLATE</p>	<p>Type C truss Apex Plate</p>	
	<p>Heel Stiffening Plate. 125 x 125 x 1.5 flat sheet plate for 90 channel system heel stiffening</p>	<p>Prevents bottom chord buckling in trusses for sheet roofs</p>	
	<p>Heel Stiffening Plate. 100 x 100 x 1.5 flat sheet plate for 75 channel system heel stiffening</p>	<p>Prevents bottom chord buckling in trusses for sheet roofs</p>	
	<p>200 x 35 x 1.5mm (Angle lintel) Heel G stiffening plate</p>	<p>Stiffener for Heel G. Suitable for 75mm and 90mm chord sections.</p>	
	<p>35mm x 35mm x 200mm x 1.0 mm</p>	<p>Knee stiffener for type C and Type D,</p>	



81 PLAN - RADIAL ROOF BARREL  
SCALE NTS @ A4



Barrel Bracket

Supports primary and secondary trusses on radial roof. Made from 1.6 mm galvanised steel, 300mm deep, 852mm unfolded width

Angle lintel - 200 x 35 x 1.5mm  
Galvanised Section Minimum  
90mm long

Truss web stiffener

## 8.0 Definitions of terms

Term	Definition
<b>Bottom Chord Tie</b>	Section fixed at right angles to the bottom chord to provide lateral restraint.
<b>Bracing - Roof</b>	Bracing fitted diagonally over a roof plane from the top plate to the ridge line to transfer bracing loads in to the supporting structure.
<b>Bracing - Strap</b>	Light-gauge metal strap 25x1 used to brace roof frames. Two straps diagonally opposed on one plane form one brace.
<b>Bracing - Wall</b>	Component fixed to the face of a wall panel to provide shear strength in the plane of the wall. Bracing may be Strap, Panel or K type.
<b>Bridge Bracket</b>	Connects a bridge truss to a girder truss.
<b>Chords</b>	Steel components forming the external perimeter of a truss.
<b>Cladding</b>	Wall or roof lining- Covering to structural frame to provide weather protection to the building.
<b>Common Rafter</b>	Member on a hip end supported by truncated trusses and supporting roof battens.
<b>Creeper Rafter</b>	Member on a hip end supported by the hip rafter and end wall supporting roof battens.
<b>Dutch Gable (Dutch Hip)</b>	Block end type where the rafter face is truncated by a vertical face some distance back from the hip end pitching line.
<b>Eave Block</b>	Block outside the building pitching perimeter defining the extent of rafter or truss top chord extension past the pitching line.
<b>Gable ladder</b>	Pre-fabricated panel used to form a gable overhang.
<b>Gridlines</b>	Series of equal spaced vertical and horizontal reference lines with origin at the building Start point.  They offset in both polar directions towards the two ends of the building. Grid-lines may form the basis of stud-spacing, truss spacing or wall cladding joint location.
<b>Heel</b>	Truss connection at an end support point.
<b>Hip Line</b>	Interface between block faces where the difference between the two adjoining block top faces is more than 180 degrees .
<b>Hip Rafter</b>	Pre-fabricated member from channel section running down the hip ridges supporting creeper rafters and battens.
<b>Load Bearing Wall</b>	Wall that carries vertical loads from the construction above and or lateral loads resulting from the wind. Internal or external walls can be load bearing.
<b>Non-Load Bearing walls</b>	Internal walls that do not support roof or floor loads are considered non load-bearing. However Internal walls may be used as lateral bracing walls and are required to resist internal wind pressures.
<b>Panel Point</b>	Connection point of a truss web to a chord.
<b>Pitching line</b>	External perimeter of a buildings roof. It is the intersection between the bottom of a truss bottom chord and the bottom of a truss top chord or for cut off or half trusses of the bottom chord and the external face of the end chord. It is often aligned with the external face of an external wall.
<b>Temporary Braces</b>	Structural sections used to brace trusses in position before the application of permanent bracing. Temporary bracing must be fastened for solid support.
<b>Shear wall</b>	Structural system consisting of flat tensile braces, studs and hold-down connectors. It is used to resist racking loads and is discretely placed within a wall panel to transfer racking loads to the foundation.  <div style="border: 1px solid red; padding: 5px; text-align: center;"><b>Warning:</b> Wall breakpoints should <b>not</b> be placed within the location of a shear wall brace.</div>
<b>Rafters - Common</b>	Rafters positioned in standard locations extending from hip rafter to fascia supported by truncated trusses.

<b>Rafter - Crown</b>	Rafter positioned at the centre of a standard hip face running from the intersection point of the hip lines to the outside edge of the eave block.
<b>Rafters - Creeper</b>	Rafters positioned in a hip that are not supported by trusses but by hip rafters, load bearing walls or fascias only.
<b>Rafter Face</b>	Top face of a roof block whose battens are supported by rafters. Standard faces are triangular and extend over the entire width of a rectangular block end.
<b>Rafters - Hip</b>	Hip rafters provide rafter and batten support at the edge of a rafter face where the difference between the two adjoining block top faces is more than 180 degrees.
<b>Rafters - Valley</b>	Valley rafters provide rafter and batten support at the edge of a rafter face where the difference between the 2 adjoining block top faces is less than 180 degrees.
<b>Ridge</b>	Interface between two block faces where the difference between the 2 adjoining block top faces is more than 180 degrees.
<b>Soffit</b>	Finished underside of a roof overhang or porch ceiling that covers the rafter bottoms or eaves.
<b>Trained Software User</b>	Individual that has completed a structured training program under the supervision of an approved Bluescope Steel Trainer. That person must hold a current certificate from BlueScope Steel stating they are qualified to design and detail residential structures, utilising the ENDUROCAD® software, which are fit for manufacture and erection.
<b>Truss Station</b>	In a Hip end, the truss station is its position from the hip end pitching line expressed in terms of mm or truss spans. eg where trusses are spaced at 600mm centres the first or 600mm station truss is placed 600mm from the hip end pitching line.
<b>Valley End</b>	Combination of Girder Truss supporting bridge trusses in an adjoining roof block and Saddle trusses forming the ridge line between the 2 blocks.
<b>Valley Line</b>	Interface between two block faces where the difference between the 2 adjoining block top faces is less than 180 degrees.
<b>Webs</b>	Steel Members that join the top and bottom chords of a roof or floor Truss, which form triangular patterns usually carrying tension or compression forces.
<b>Wind Bracing</b>	Bracing fitted diagonally over the roof plane from the top plate to the ridge line to transfer bracing loads in to the supporting structure.
<b>Whaling Plate</b>	Length of chord section fixed to the outside face of a dutch gable truss to support common rafters

## 9.0 References

AS4055: 2011 Wind Loads for Housing

AS4440: 2004 Installation of nail plated timber roof trusses

AS3566.1: 2002 Self-drilling screws for the building and construction industries

NASH Handbook Low Steel Framing, National Association of Steel Framed Housing 2011

NASH Standard - Residential and Low Rise Steel Framing: Part 1, Design Criteria, National Association of Steel Framed Housing 2005

AS1397:2011 Steel sheet and strip - Hot-dipped zinc-coated or aluminium/zinc-coated - Continuous hot-dip metallic coated steel sheet and strip - Coatings of aluminium, zinc and magnesium

### **Disclaimer, warranties and limitation of liability**

This publication is intended to be an aid for all trades and professionals involved with specifying and installing ENDUROTRUSS® products and not to be a substitute for professional judgement.

Except to the extent to which liability may not lawfully be excluded or limited, BlueScope Steel Limited will not be under or incur any liability to you for any direct or indirect loss or damage (including, without limitation, consequential loss or damage such as loss of profit or anticipated profit, loss of use, damage to goodwill and loss due to delay) however caused (including, without limitation, breach of contract, negligence and/or breach of statute), which you may suffer or incur in connection with this publication.

© Copyright BlueScope Steel Limited 27 April 2016

Information, brochures and your local distributor:

**[www.enduroframe.com](http://www.enduroframe.com)**

BLUESCOPE, TOPSPAN, TRUECORE ENDUROFRAME, ENDUROTRUSS, ENDUROCADD and ENDURO are all registered trademarks of BlueScope Steel Limited, ABN 16 000 011 058. Pryda®, BattenZip® and Tek® are registered trademarks of ITW Australia Pty Ltd.