

ENDURO FRAME[®]

ENDUROFLOOR[®] System Installation Manual

Find the latest version at <https://enduroframe.atlassian.net/wiki/display/IM/>

© BlueScope Steel Ltd.

ENDUROFLOOR™ Installation Manual

Table of Contents

- 1 Overview
- 2 Scope of Manual
 - 2.1 Product performance
 - 2.2 General notes to be read before you use this manual.
 - 2.3 Important disclaimer about this construction manual
- 3 References
- 4 Design
- 5 Required on-site Tools and Equipment
 - 5.1 Power Tools
 - 5.2 Tool Accessories
 - 5.3 Hand Tools
 - 5.4 Essential Safety Equipment
- 6 Material specification
- 7 Components
 - 7.1 Rollformed Sections
 - 7.2 Lintels
 - 7.3 Fasteners
 - 7.4 Brackets
 - 7.5 Bracing & Blocking
 - 7.6 Beams & Bearers
- 8 Truss Connections
- 9 Notes on Vibration
- 10 Truss Assemblies
 - 10.1 General
 - 10.2 Flush Truss
 - 10.3 Pre Camber
 - 10.4 Manufacturing Crib Allowance
 - 10.5 Floor truss component cribbing for Independent wall systems
 - 10.6 Floor truss component cribbing for Integrated wall systems
 - 10.7 Standard Floor Truss
 - 10.8 Design Options
- 11 Handling of Endurofloor trusses
- 12 Floor trusses exposure and storage
- 13 Truss identification
 - 13.1 Standard Floor truss
 - 13.2 Stepdown Truss
 - 13.3 Cantilever Floor Truss
- 14 Truss Assembly
 - 14.1 Chord to chord connection identification
 - 14.2 Connections
 - 14.3 Standard Truss Assembly
 - 14.4 ENDUROFLOOR™ Floor Framing System stiffening and reinforcement
 - 14.5 Web connection stiffening
 - 14.5.1 Maximum Joist Spans for Domestic Floors – Dead Load 0.6 kPa Live Load 1.5 kPa Notes:
 - 14.5.2 Maximum Joist Spans for Domestic Floors – Dead Load 1.0 kPa Live Load 1.5 kPa Notes:
 - 14.6 Chord Boxing
- 15 Points for construction
 - 15.1 Correct direction of ENDUROFLOOR™ chord profile
 - 15.2 Straightness
 - 15.3 Plumb
- 16 Floor Construction
 - 16.1 General and design
 - 16.2 Prior to construction
 - 16.3 Independent wall to floor system
 - 16.3.1 On-site installation
 - 16.3.2 Prefabrication
 - 16.4 Integrated wall to floor system
 - 16.5 End wall lintel
 - 16.6 Ceiling battens and plasterboard angles
 - 16.7 Internal wall support and shear transfer
 - 16.8 Installation of flooring



Table of Figures

- 1 ENDUROFRAME® sections
 - 1.1 Detail: Floor truss component cribbing - Independent wall system
 - 1.2 Detail: Floor truss component cribbing - Integrated wall system
 - 1.3 Detail: Typical standard floor truss - all webs at 45 degrees
 - 1.4 Detail: Typical standard floor truss - middle webs at minimum 35 degrees
 - 1.5 Detail: Typical standard floor truss - middle webs greater than 45 degrees
 - 1.6 Detail: Typical standard floor truss - Context and components
 - 1.7 Detail: End connection punch locations
 - 1.8 Detail: Typical floor
 - 1.9 Detail: Standard floor truss
 - 1.10 Detail: Stepdown truss
 - 1.11 Detail: Cantilever area truss
 - 1.12 Detail: Floor truss to end wall connection - typical (Independent and Integrated wall types)
 - 1.13 Detail: Typical web to chord connection - typical
 - 1.14 Detail: Stepdown connection - typical
 - 1.15 Detail: Stepdown to end wall connection - typical (Independent and Integrated wall types)
 - 1.15.1 Detail: Initial chord placement
 - 1.15.2 Detail: Hole alignment and trusstite installation
 - 1.15.3 Detail: Web separation
 - 1.15.4 Detail: Web placement
 - 1.15.5 Detail: Web fixing
 - 1.15.6 Detail: Check measure
 - 1.15.7 Detail: Reinforcement screw installation
 - 1.16 Detail: Screw distances
 - 1.17 Detail: Typical standard floor truss assembly sheet
 - 1.18 Detail: Straightness
 - 1.19 Detail: Plumb
 - 1.19.1 Picture: Packing beams
 - 1.19.2 Detail: Locating support brackets
 - 1.19.3 Picture: Fixing Secondary support beams

Overview

The ENDUROFLOOR™ system has been developed as an add-on intermediate floor system to be manufactured from an ENDURO® rollformer using standard ENDUROFRAME® components. It shall be able to be manufactured from both a 75 and 90mm section. A 75mm system shall be able to be made from gauges between 0.55 – 1.2mm thick, and the 90mm system shall be able to be manufactured from 0.55 to 1.2mm thick steel. Where possible, options shall remain open so the floor system can be manufactured on a Smartruss rollformer. Due to potentially being manufactured on Smartruss rollformers – and to increase the strength of the trusses – it will be used in its strong axis.

The ENDUROFLOOR™ system is designed to be used as part of the ENDUROFRAME® system but could also potentially be used as a standalone floor system to rest on other wall frames, providing the loads are similar to an ENDUROFRAME® building system. Due to the variable and generally high corrosivity found in subfloor environments, TRUECORE® steel is not recommended for this application.

Scope of Manual

- This manual has been prepared for the construction of steel framed floors within the following parameters:
- Only ENDUROFLOOR™ components made from TRUECORE® steel and made with the ENDURO® rollformer can be used.
- Standard floor truss spacings are at 600mm or 450mm (max) centres dependent on floor truss design limitations. Other spacings may require additional engineering.
- Suitable for particle board sheeting and 75mm autoclaved lightweight concrete panels

Product performance

The ENDUROFLOOR™ system has been designed in accordance with relevant Australian Standards and the requirements of the Building Code of Australia.

The floor framing system will perform in accordance with ENDUROFLOOR™ design documentation if installed in accordance with the recommendations and details set down in this manual and related references. This manual contains vital information. **Please read it carefully.**

For more information and technical support, contact: www.enduroframe.com

Refer to www.truecore.com.au for locations where ENDUROFRAME® can be warranted.

General notes to be read before you use this manual.

1. This Manual has been prepared for a range of floor framing designs using ENDUROFLOOR™ building components manufactured from supplied by BlueScope Steel, its licensed manufacturers or dealers.
2. The ENDUROFRAME® Building System has been designed as a complete framing system.
3. All erection and connection details must be made in accordance with the relevant standard connection drawing details contained in this Manual or its supplements, or drawings output from the ENDUROCADD® software.
4. Before commencement of any fabrication or construction develop a safety management plan to cover key risks. Key risks include, but are not limited to:-
 - a. Working at heights
 - b. Electrical safety
 - c. Cuts and scratches
5. Consider and install the appropriate level of safety equipment to manage identified risks. Safety equipment that may be required includes:-
 - a. Personal protective equipment including safety glasses, gloves, hearing protection (when using power tools) and sunscreen;
 - b. Appropriate fall protection equipment including guard rails, scaffolds, ladders, elevated platforms, safety mesh, and fall restraint harnesses
 - c. A temporary earth should be established during the construction of steel frames and, upon completion, the steel house frames must be permanently earthed in accordance with the requirements of local electricity authorities.
6. You should check with your local workplace health and safety authority to see what safety measures you need to put in place prior to and during construction. It is the responsibility of the installer/erector to ensure all local safe work practices are adhered to and the safety of the whole site is maintained at all times.
7. For wiring in steel wall frames, nylon grommets shall be installed to run electrical cables through.
8. Where insufficient detail is included in this manual for your project, seek specialist advice.
9. Before you commence construction:
 - a. You should check with your local government authority to see if any form of prior permission or approval is required;
 - b. If you want to build or construct any attached structure, you should seek advice from a suitably qualified engineer to verify the capacity of your existing structure to withstand any additional load arising from the attached structure. You should also check with your local government authority to determine any specific requirements for the attachment to existing structures;
 - c. You should check with your local workplace health and safety authority to see what safety measures you need to put in place prior to and during construction. It is the responsibility of the installer/erector to ensure all local safe work practices are adhered to and the safety of the whole site is maintained at all times.
10. To ensure maximum lifespan of your house frame, consult your nearest ENDUROFRAME® fabricator for information regarding maintenance, handling, storage and any other technical assistance you may require.

Important disclaimer about this construction manual

Date of Issue

This Manual was issued on April, 2016. BlueScope Steel may make changes to this Manual in its sole discretion. You should check you are using the current version of the Manual before you start construction. Refer to www.enduroframe.com to check for the latest version.

Conditions of Use

If you use this Manual, you acknowledge and agree that your use is subject to the terms and conditions in this Manual. BlueScope Steel, its agents, officers, employees, subcontractors or consultants make no representations, either expressed or implied, as to the suitability of the information and data in this Manual for your particular purposes. It's your responsibility to ensure the design you use is appropriate for your needs, the products you have purchased, your site and structural limitations and your building and construction capabilities. It is recommended that you obtain qualified expert advice.

Use of Genuine Materials

Structures in this Manual should only be built or constructed using ENDUROFLOOR™ made from TRUECORE® steel and made with the ENDURO® rollformer or recommended third party products. Except as otherwise provided in these terms, any warranties only apply to you (if at all) if you use the genuine BlueScope Steel or recommended third party products and method of construction.

Check Delivery

It is important that you check all materials delivered to site against your invoice before you use them in your building or construction to ensure all components have arrived, are of the appropriate quality and are ready for installation.

Safety

Ensure that all barriers, scaffolding, and fall protection used in order to comply with safe work practices are installed so as not to damage or overload floor components.

Limitation of Liability

By using this Manual, you accept the risks and responsibility for all losses, damages, costs and other consequences resulting directly or indirectly from using this Manual. Except to the extent to which liability may not lawfully be excluded or limited, BlueScope Steel will not be under or incur any liability to any person for any direct or indirect loss or damage (including, without limitation, consequential loss or damage such as loss of profit or anticipated profit, loss of use, damage to goodwill and loss due to delay) however caused (including, without limitation, breach of contract, negligence, breach of statute and/or in equity), which may be suffered or incurred in connection with this Manual.

All rights reserved. No part of this brochure may be reproduced, stored in a retrieval system, or transmitted in any form or by any means, electronic, mechanical, recording or otherwise, without written permission of BlueScopeSteel Limited. ABN 16 000 011 058

References

The following documents have been used in the development of this system:

- NASH Standard – Residential and Low-Rise Steel Framing Part 1: Design Criteria (2005)
- NASH Handbook – Design of residential & Low-rise Steel Framing (2009)
- NASH Technical Note 2 – Six Star Energy Efficiency Measures for Houses (March 2011)
- National Construction Code (Building Code of Australia - 2010), Australian Building Codes Board
- AS1170 AS/NZS 1170:2002 - Structural Design Actions - Australian/New Zealand Standard

Part 1: Permanent, imposed and other actions principles

- AS1170 AS/NZS 1170:2011 - Structural Design Actions - Australian/New Zealand Standard

Part 2: Wind actions

- AS/NZS 4600:2005 - Cold-formed steel structures - Australian/New Zealand Standard
- AS4055:2006 - Wind loads for Housing - Australian Standard
- AS 1684.2-2010 - Residential timber-framed construction – Non-cyclonic areas - Australian/New Zealand Standard
- ABCB Protocol for Structural Software Draft Version 2010.1
- Minister's Specification SA A2.2 'Structural Engineering Software'
- NASH standard Residential and Low rise steel framing

Design

Components used in the ENDUROFLOOR™ system are specified by an ENDUROCAD® software Trained Software User referencing loads and span tables contained in the ENDUROFLOOR™ Design Manual. Any floors designed outside the scope of this Design Manual must be checked and signed off by a suitably qualified engineer. Any supporting beams, and connections required in the floor structure should be specified by others.

Required on-site Tools and Equipment

When installing an ENDUROFLOOR™ Floor Framing System, the following tools and safety equipment may be required.

Power Tools

- screw gun
- metal cutting saw
- hand held metal cutting saw
- angle grinder

Tool Accessories

- 8mm (5/16") hexagon socket
- extension bar (length up to 150mm)
- suitable metal cutting blades
- 8mm (5/16") spanner or socket and handle
- No.2 and No.3 Phillips head driver bits (length up to 100mm)

Hand Tools

- double action tin snips (left, right and straight cut)
- spirit level
- chalk line
- step ladder
- vice grips
- measuring tape

Essential Safety Equipment

- eye protection (safety goggles)
- hearing protection (when using power tools)
- protective gloves
- earth leakage circuit breaker for electrical equipment
- fall protection harness
- scaffolding, ladders, etc.

Material specification

ENDUROFLOOR™ sections are roll-formed from TRUECORE® steel complying with AS1397:2011. The standard ENDUROFLOOR™ sections are shown in Figure x.x. In the grade shown, the number prefixed with G indicates minimum yield stress in MPa; and the number prefixed with Z or AM indicates minimum coating mass in g/m².

- 0.55mm BMT, TRUECORE® G550 AM150 steel
- 0.75mm BMT, TRUECORE® G550 AM150 steel
- 1.00mm BMT, TRUECORE® G550 AM150 steel
- 1.20mm BMT, TRUECORE® G500 AM150 steel

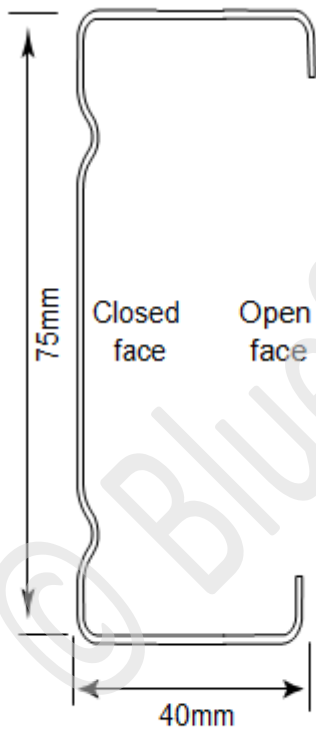

S75 Section

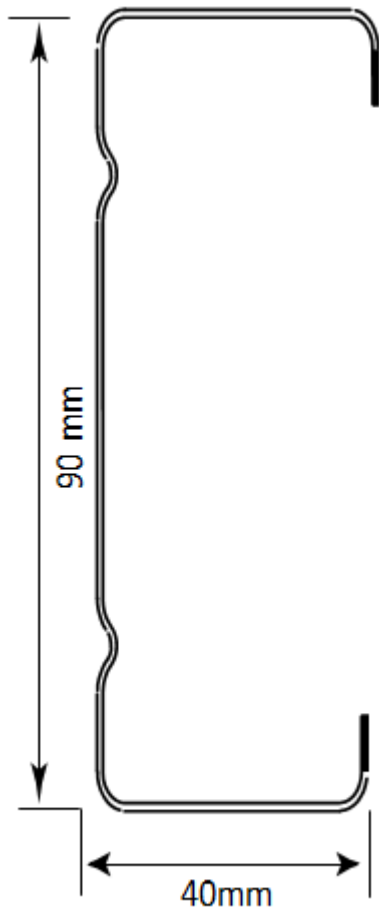

S90 Section

ENDUROFRAME® sections

Components

A full list of components can be seen at this link - <https://enduroframe.atlassian.net/wiki/x/L4Ms>.

Rollformed Sections

CEE section definition	Part No.	t	D	B1	B2	L	Feed Width mm	Section Type	Cee Sections
		mm	mm	mm	mm	mm			
Grade G550	C7575ra	0.75	75	40	38	8	163	Ribbed	ENDUROTRUSS® & ENDUROWALL®
	C7510ra	1.00	75	40	38	8	163	Ribbed	
	C9075ra	0.75	90	40	38	9	178	Ribbed	
	C9010ra	1.00	90	40	38	9	178	Ribbed	
	C9012ra	1.20	90	40	38	9	178	Ribbed	

U section definition	Part Code	t	D	B1	B2	Feed width mm	Usage
		mm	mm	mm	mm		



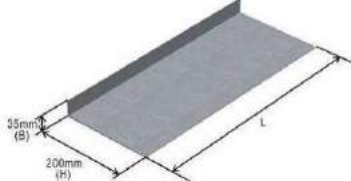

	U754475G550	0.75	78.5	43	45	163	Dwarf plate
	U754410G550	1.00	78.5	43	45	163	Dwarf plate
	U904475G550	0.75	93.5	43	45	178	Dwarf plate
	U904410G550	1.00	93.5	43	45	178	Dwarf plate
	U904412G550	1.20	93.5	43	45	178	Dwarf plate

Lintels

Picture	Size	Application	Part No.
	200 x 35 x 1.5	Single lintel used to resist roll-over of floor trusses at ends.	

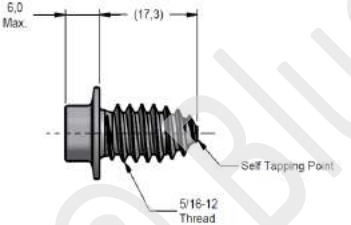
Fasteners

The following fasteners are used in this system:

Picture	Description	Application	Supplier
	5/16-12 x 17 Hex Washer Trusstite Or 17-15 x 15mm GX screw Trilobular thread form	Primary connection of truss components through pre-punched holes. Both screws listed are suitable for the application.	ITW Buildex, Bremick, Ideal, Powers
	#10-16x16 hex head self drilling screw.	Low strength fixing- ceiling batten fix, chord and web boxing. Used in all wall systems	ITW Buildex, Bremick, Ideal, Powers
	Wall fastener – M6 x 1P x 15mm Smooth Top GX screw Wall tite (Trilobular thread form)	Connecting wall frame components together through pre-punched holes. Used in ENDUROWALL™ FRAMING SYSTEM,	ITW Buildex, Bremick, Ideal, Powers
	#12-14x20 hex head self drilling screws	General Framing Screw- Roof, Wall and Floor frame installation Used as reinforcing in truss manufacture.	ITW Buildex, Bremick, Ideal, Powers

	M6,0 x1P x 18,0 Smooth Top Gx Teks	Stiffening stud to plate connections and connecting lintels to plates	ITW Buildex, Bremick, Ideal, Powers
--	---------------------------------------	--	---

All fasteners shall be min. AS3566.2 Class 3 with the exception that class 4 fasteners should be used at less than 400m from high water mark of surf or exposed salt marine influences. Do not use stainless steel fasteners with steel framing made from TRUECORE[®] steel.

Where a manufacturer is specified, alternative products may be used providing all corrosion and mechanical properties are the same as those supplied by the specified manufacturer and in compliance with AS3566.2 Class 3. All screws shall have shear and pull out values at least equivalent to those shown above

The use of the correct fasteners in the quantities shown in the truss fabrication drawings are essential to ensure the design capacity of the trusses are achieved.

Brackets

Picture	Description	Application	Supplier	Part No.
	CPAH Hold down bracket 1.9 mm B.M.T. Zincform G450 Z275	Hold down bracket to connect joists to masonry walls	Pryda	CPAH
	Purlin cleats 100AC - 90x70EA 150AC - 140x70EA 200AAC - 190x70EA 250AAC - 240x70EA	Connecting purlins to purlins	Lysaght	

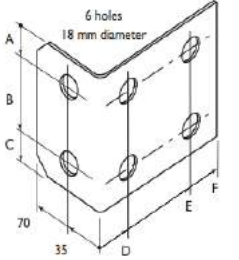
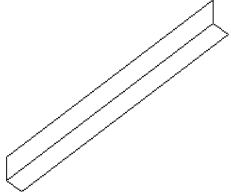
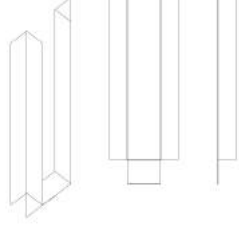
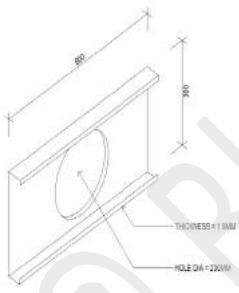
<p>2) General Purpose brackets</p>  <table border="1" data-bbox="199 470 438 582"> <thead> <tr> <th>Product Code</th> <th>A</th> <th>B</th> <th>C</th> <th>D</th> <th>E</th> <th>F</th> </tr> </thead> <tbody> <tr> <td>100GPB</td> <td>13</td> <td>53</td> <td>66</td> <td>30</td> <td>84</td> <td>115</td> </tr> <tr> <td>150GPB</td> <td>22.5</td> <td>82.5</td> <td>105</td> <td>30</td> <td>97</td> <td>125</td> </tr> <tr> <td>200GPB</td> <td>22</td> <td>132</td> <td>154</td> <td>36</td> <td>109</td> <td>136</td> </tr> <tr> <td>250GPB</td> <td>20</td> <td>180</td> <td>200</td> <td>36</td> <td>109</td> <td>136</td> </tr> </tbody> </table>	Product Code	A	B	C	D	E	F	100GPB	13	53	66	30	84	115	150GPB	22.5	82.5	105	30	97	125	200GPB	22	132	154	36	109	136	250GPB	20	180	200	36	109	136	General purpose brackets	Connecting purlins to purlins	Lysaght
Product Code	A	B	C	D	E	F																																
100GPB	13	53	66	30	84	115																																
150GPB	22.5	82.5	105	30	97	125																																
200GPB	22	132	154	36	109	136																																
250GPB	20	180	200	36	109	136																																
	ENDURO angle 45 x 45 x 1mm	Trimmer Ceiling trim																																				
	Enduro Floor Truss Bracket 35 x 35 x 1mm	Connection and support of floor trusses to bearers/beams																																				
	SFS stiffening plate	Insert an oversized service penetration in a 300mm floor truss in its vertical axis. Length = 600mm Can also be used on a 350mm deep floor truss in its vertical axis. Length = 350mm.	SFS																																			

Bracing & Blocking



Picture	Description	Application	Supplier	Part No.
---------	-------------	-------------	----------	----------

	Speedbrace Z275 ZincForm® Steel G300	Rollover resistance brace	Pryda	SDB
	Strap bracing 25 x 1.0, G250 25 x 1.2, G250 32 x 1.0, G250 32 x 1.2, G250 51 x 1.2, G550 70 x 1.0, G250	Rollover resistance brace Diaphragm bracing	Lysaght	

Beams & Bearers

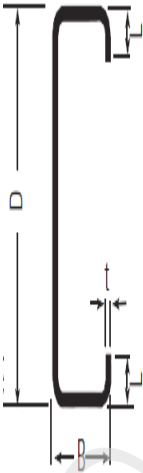
Sections to be permitted for use in-plane, below floor truss or for cantilever applications. Ref: Table below

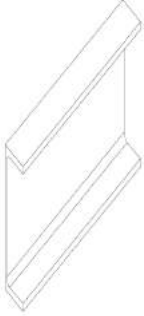
Section Definition	Section Type	Part No.	t	D	B	L	Kg/m	Supplier
			mm	mm	mm	mm		
	Purlin	C10010	1.0	102	51	12.5	1.78	Lysaght
	Purlin	C10012	1.2	102	51	12.5	2.10	Lysaght
	Purlin	C10015	1.5	102	51	13.5	2.62	Lysaght
	Purlin	C10019	1.9	102	51	14.5	3.29	Lysaght
	Purlin	C15012	1.2	152	64	14.5	2.89	Lysaght
	Purlin	C15015	1.5	152	64	15.5	3.59	Lysaght
	Purlin	C15019	1.9	152	64	16.5	4.51	Lysaght
	Purlin	C15024	2.4	152	64	18.5	5.70	Lysaght
	Purlin	C20015	1.5	203	76	15.5	4.49	Lysaght
	Purlin	C20019	1.9	203	76	19.0	5.74	Lysaght
	Purlin	C20024	2.4	203	76	21.0	7.24	Lysaght
	Purlin	C25019	1.9	254	76	18.5	6.50	Lysaght
	Purlin	C25024	2.4	254	76	20.5	8.16	Lysaght
	Purlin	C30024	2.4	300	96	27.5	10.09	Lysaght
	Purlin	C30030	3.0	300	96	31.5	12.76	Lysaght
	Purlin	C35030	3.0	350	125	30.0	15.23	Lysaght
Purlin	SC40024	2.4	400	125		13.16	Lysaght	

	Purlin	SC40030	3.0	400	125		16.39	Lysaght
	PFC	150	*	150	75	N/A	17.7	
	PFC	180	*	180	75	N/A	20.9	
	PFC	200	*	200	75	N/A	22.9	
	PFC	230	*	230	75	N/A	25.1	
	PFC	250	*	250	90	N/A	35.5	
	PFC	300	*	300	90	N/A	40.1	
	PFC	380	*	380	100	N/A		
	UB	150UB14.0	*	150	75	N/A	14.0	
	UB	150UB18.0	*	155	75	N/A	18.0	
	UB	180UB16.1	*	173	90	N/A	16.1	
	UB	180UB18.1	*	175	90	N/A	18.1	
	UB	180UB22.2	*	179	90	N/A	22.2	
	UB	200UB18.2	*	198	99	N/A	18.2	
	UB	200UB22.3	*	202	133	N/A	22.3	
	UB	200UB25.4	*	203	133	N/A	25.4	
	UB	200UB29.8	*	207	134	N/A	29.8	
	UB	250UB25.7	*	248	124	N/A	25.7	
	UB	250UB31.4	*	252	146	N/A	31.4	
	UB	250UB37.3	*	256	146	N/A	37.3	

UB	310UB32.0	*	298	149	N/A	32.0		
UB	310UB40.4	*	304	165	N/A	40.4		
UB	310UB46.2	*	307	166	N/A	46.2		
	RHS	150 X 50	2	150	50	N/A	6.07	
			2.5	150	50	N/A	7.53	
			3	150	50	N/A	8.96	
			4	150	50	N/A	11.6	
			5	150	50	N/A	14.2	
			6	150	50	N/A	16.7	
	RHS	125 X 75	2	125	75	N/A	6.07	
			2.5	125	75	N/A	7.53	
			3	125	75	N/A	8.96	
			4	125	75	N/A	11.6	
			5	125	75	N/A	14.2	
			6	125	75	N/A	16.7	
	RHS	100 X 50	1.6	100	50	N/A	3.64	
			2	100	50	N/A	4.50	
			2.5	100	50	N/A	5.56	
			3	100	50	N/A	6.60	
			3.5	100	50	N/A	7.53	
			4	100	50	N/A	8.49	
			5	100	50	N/A	10.3	
			6	100	50	N/A	12.0	
	RHS	75 X 50	1.6	75	50	N/A	3.01	
			2	75	50	N/A	3.72	
			2.5	75	50	N/A	4.58	
			3	75	50	N/A	5.42	
4			75	50	N/A	6.92		

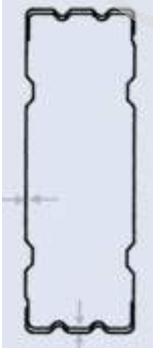
			5	75	50	N/A	8.35	
			6	75	50	N/A	9.67	
	SHS	100 X 100	2.5	100	100	N/A	7.53	
			3	100	100	N/A	8.96	
			4	100	100	N/A	11.6	
			5	100	100	N/A	14.2	
	SHS	90 X 90	2	90	90	N/A	5.45	
			2.5	90	90	N/A	6.74	
			3.5	90	90	N/A		
	SHS	75 X 75	2	75	75	N/A	4.5	
			2.5	75	75	N/A	5.56	
			3	75	75	N/A	6.60	
			3.5	75	75	N/A	7.53	
			4	75	75	N/A	8.49	
			5	75	75	N/A	10.3	
			6	75	75	N/A	12.0	
	Boxspan	100 x 50-12	0.6	100	50	N/A	2.05	Spantec
	Boxspan	100 x 50-16	0.8	100	50	N/A	2.71	Spantec
	Boxspan	150 x 50-12	0.6	150	50	N/A	2.51	Spantec
	Boxspan	150 x 50-16	0.8	150	50	N/A	3.33	Spantec
	Boxspan	150 x 50-20	1.0	150	50	N/A	4.14	Spantec
	Boxspan	200 x 50-16	0.8	200	50	N/A	3.94	Spantec
	Boxspan	200 x 50-20	1.0	200	50	N/A	4.91	Spantec

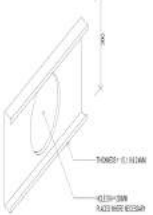
	Boxspan	250 x 50-20	1.0	250	50	N/A	5.68	Spantec
	SFS Rollformed Joist		1.5, 1.9 & 2.4mm	300	50	N/A		SFS

Truss Connections

Chord to chord connections do not have any name, and are treated the same as webs. The only information that is recorded in the connection are the number of fasteners, and these shall be the same for connection at each end of the chord or web.

The only other type of connection is a step down connection which will be referred to as SD-6 which indicates the number of self tapping fasteners connecting the top chord with the step down chord.

The number of screws indicated is the combined number of Trusstite and reinforcing screws.

When assembling trusses adopt the following rules for screw placement:-

- Screws should be placed a minimum of 18mm centre to centre
- Screws should be placed a minimum of 10mm from the end of a component
- Screws should be placed a minimum of 8mm from the edge of a component
- Screws should be placed where shown on the connection drawings within the above spacing constraints

Note

- Connections external to the truss - e.g. Bridge truss to Girder Truss, Rafter to truss, truss to support - are covered in the relevant block assembly sections of this manual.

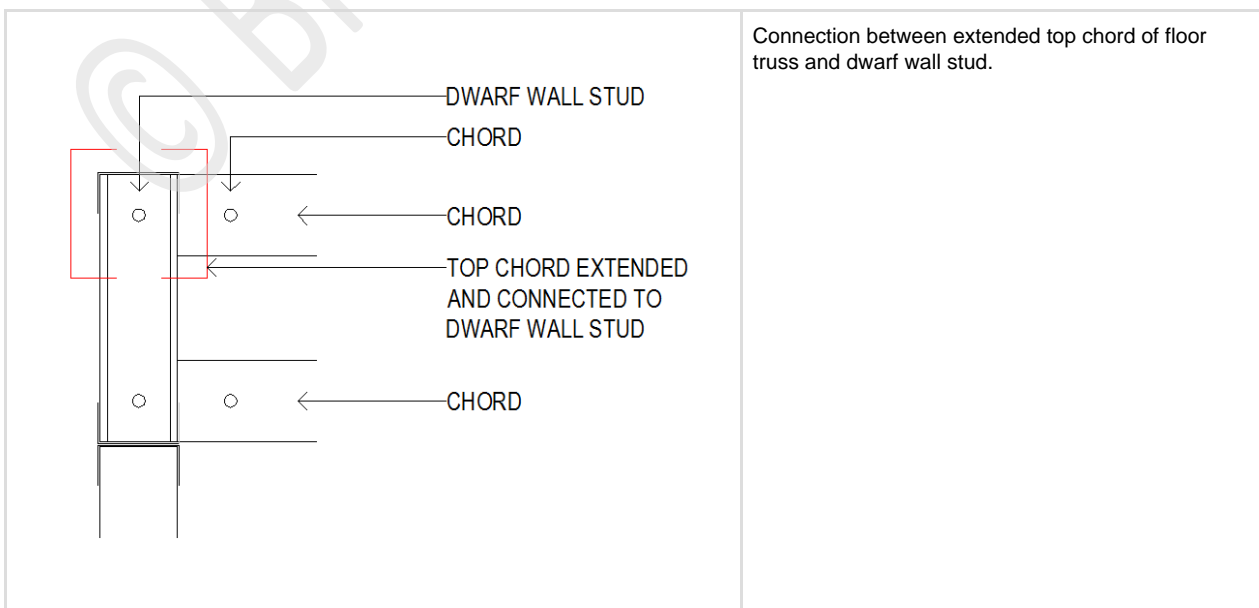

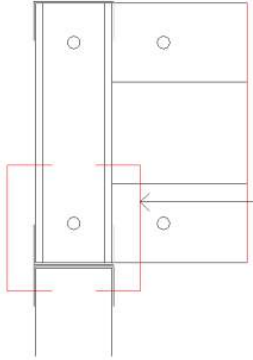
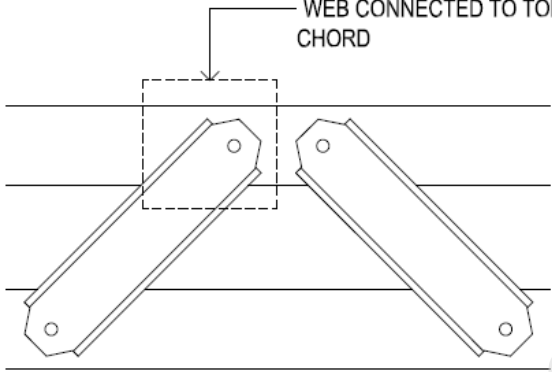
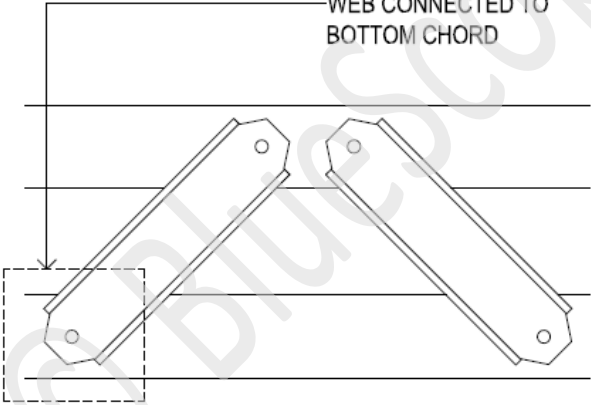
 <p data-bbox="598 398 842 510">BOTTOM CHORD EXTENDED AND CONNECTED TO DWARF WALL STUD</p>	<p data-bbox="914 159 1412 208">Connection between extended bottom chord of floor truss and dwarf wall stud.</p>
 <p data-bbox="550 689 821 745">WEB CONNECTED TO TOP CHORD</p>	<p data-bbox="914 633 1412 683">Connection between web and top horizontal chord of floor truss.</p>
 <p data-bbox="555 1182 786 1238">WEB CONNECTED TO BOTTOM CHORD</p>	<p data-bbox="914 1142 1369 1191">Connection between web and bottom horizontal chord of floor truss.</p>

<p>WEB CONNECTED TO TOP CHORDS</p> <p>45°</p> <p>100 100 100</p>	<p>Compound connection for use in set downs such as bathroom wet areas and balconies. This connection complies SD-7 Vertical chords and webs are non-flush only. Top chord of lower RL area is to be notched along its length to fit over the top chord of the higher RL area.</p>
<p>WEB CONNECTED TO BOTTOM CHORD</p> <p>45°</p> <p>100 100 100</p>	<p>Compound connection for use in set downs such as bathroom wet areas and balconies. This connection complies SC-STEP-N-90-XX Vertical chords and webs are non-flush only.</p>
<p>TRUSS WEB</p> <p>PUNCH TOP PLATE FOR CLEARANCE IF TOP CHORD IS 44MM OR LESS OF STEPDOWN HEIGHT</p> <p>CHORDS EXTENDED AND CONNECTED TO DWARF WALL / INTEGRATED WALL STUD</p>	<p>Connection between floor joist step down and end wall.</p>

Notes on Vibration

Sound Dampening between chords and webs can be seen at this link - <https://enduroframe.atlassian.net/wiki/x/J4A3>.

Floor vibration from general footfall traffic is subjective to each end user. Some people prefer a tight (high frequency) floor whilst others prefer a floor with more resilience (bounce). Each floor design is affected by multiple circumstances including joist span and spacing, flooring type and thickness, furniture supported, loads imposed from roof and supporting walls and supported partition (non-loadbearing) walls.

The ENDUROFLOOR™ system defined in this manual has been tested to have a minimum harmonic frequency of 8 Hz with joists at a maximum span and centres indicated in the attached span tables, and sheathed with either 22mm or 19mm particleboard flooring fixed in accordance to AS1860. This value is considered to be acceptable in most circumstances.

Where a higher frequency (tighter) floor is required, reduced spans, the use of stiffer/thicker flooring or an extra layer of flooring may be utilised with varied results.

Truss Assemblies

General

For ENDUROTRUSS® pre-punched holes are formed in chords and webs during rollforming. The perimeter chords are connected using TRUSSTITE® fasteners at changes in direction. The primary shape is formed by aligning pre-punched holes in the adjacent chord members and inserting a TRUSSTITE® screw to form a connection. Additional screws, stiffeners or brackets may be required to form the connection. Webs join the chords of a truss forming triangular patterns transmitting tension or compression stresses. The web to chord connections are formed by aligning the pre-punched holes in the end of the webs with pre-punched holes along the chord members and inserting a TRUSSTITE® fastener. Additional self drilling screws may be required to add strength to the connection. The full geometry of the truss is set by the connection of the pre-punched and notched components. ENDUROTRUSS® Channels have one flange wider than the other enabling the boxing of the section forming a tubular section with high torsional strength. To facilitate the boxing of chords after assembly the narrow flange must be placed on the external perimeter of the truss and on the top of horizontal rails within the truss.

Flush Truss

Flush truss is not an option with the ENDUROFLOOR™ truss system.

Pre Camber

There will be no pre-camber in the floors design or manufacture.

Manufacturing Crib Allowance

Crib lengths are necessary for trusses to fit in between walls and beams. The standard crib length is 2mm *from each end* of a truss but can be adjusted as necessary by the Trained Software User in the ENDUROCAD software. The following crib lengths shall be assumed:-

- Beam lengths - User defined
- Length of trusses between 2 walls - 4mm or user defined
- Length of trusses between 2 beams - 10mm or user defined
- Length of trusses between a beam and a wall 5mm or user defined

Floor truss component cribbing for Independent wall systems

	A	B	C	D	E	F	G
ENDURO 75	37	35	80	75	T/D	=E	E+4MM
ENDURO 90	45	43	100	93	T/D	=E	E+4MM

TOP AND BOTTOM CHORDS TO BE CRIBBED 2MM AT EACH END IN ALL CASES

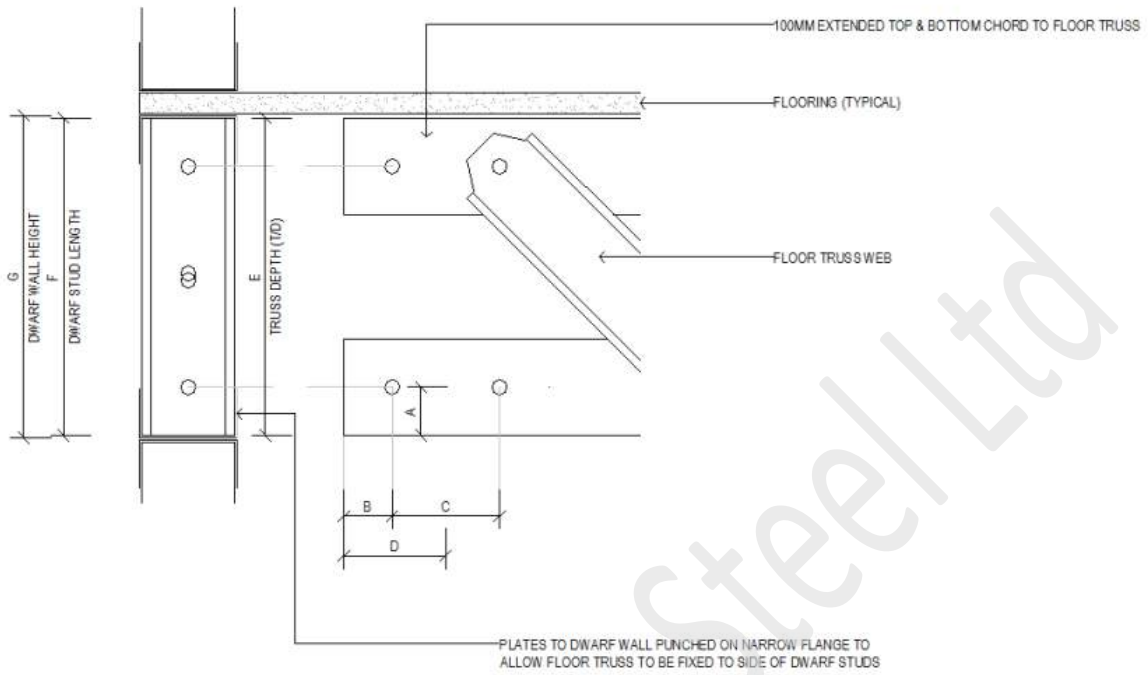

Detail: Floor truss component cribbing - Independent wall system

Floor truss component cribbing for Integrated wall systems

	A	B	C	D	E	F	G
ENDURO 75	37	35	80	75	T/D	E+1MM	E+1MM
ENDURO 90	45	43	100	93	T/D	E+1MM	E+1MM

TOP AND BOTTOM CHORDS TO BE CRIBBED 2MM AT EACH END IN ALL CASES

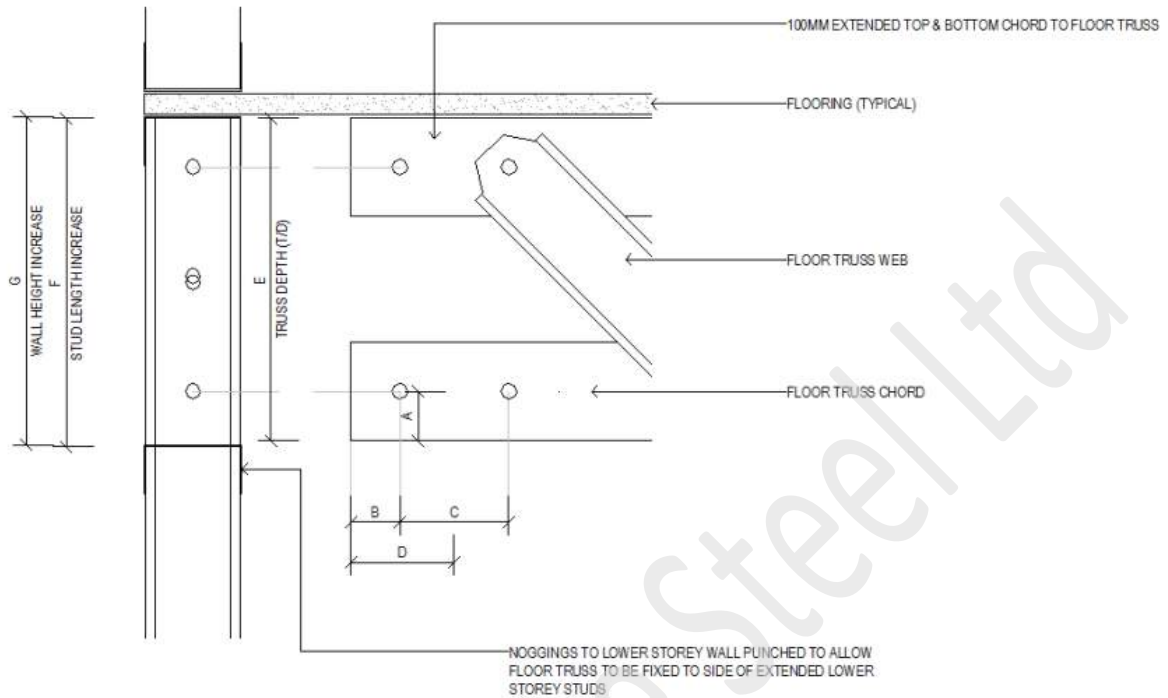

Detail: Floor truss component cribbing - Integrated wall system

Standard Floor Truss

A standard floor truss has the top and bottom chord running parallel (vertical end chords may be used where specified). The end of a standard floor truss may either sit on top of a load bearing wall or bearer, fit into an integrated wall or butt up against a beam. Vertical webs are placed directly above, below or between load bearing walls and supporting beams. Common webs will be placed at 45 degrees from the end of the floor truss starting at the top chord, and any non-standard webs are in the middle of the truss span. This may mean that 2 webs in the centre of the truss are non-standard lengths and can vary between 35 degrees to 90 degrees (vertical).

In order to simplify manufacturing and assembly of trusses, standard lengths are used for webs and vertical chords (where specified). This will enable standard parts to be pre-made and stored, and will make it easier to find parts during assembly. Only non-standard length parts will therefore need to be defined on assembly sheets which will greatly de-clutter drawings given these trusses will be quite dense. Location of standard webs shall be placed from the outside (support locations) working inward toward the middle of the span. In the majority of cases, this would only require a maximum of 2 webs to be individual.

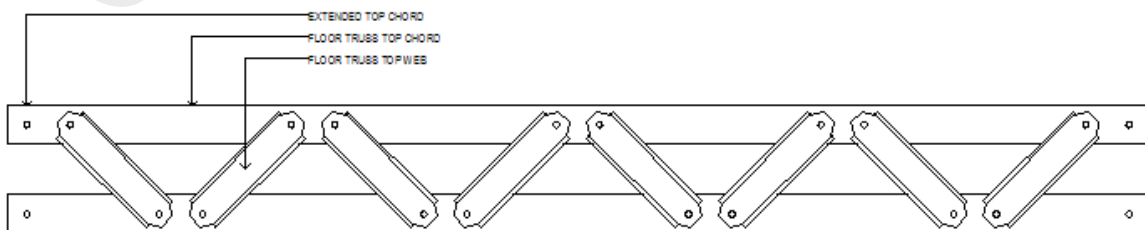

Detail: Typical standard floor truss - all webs at 45 degrees

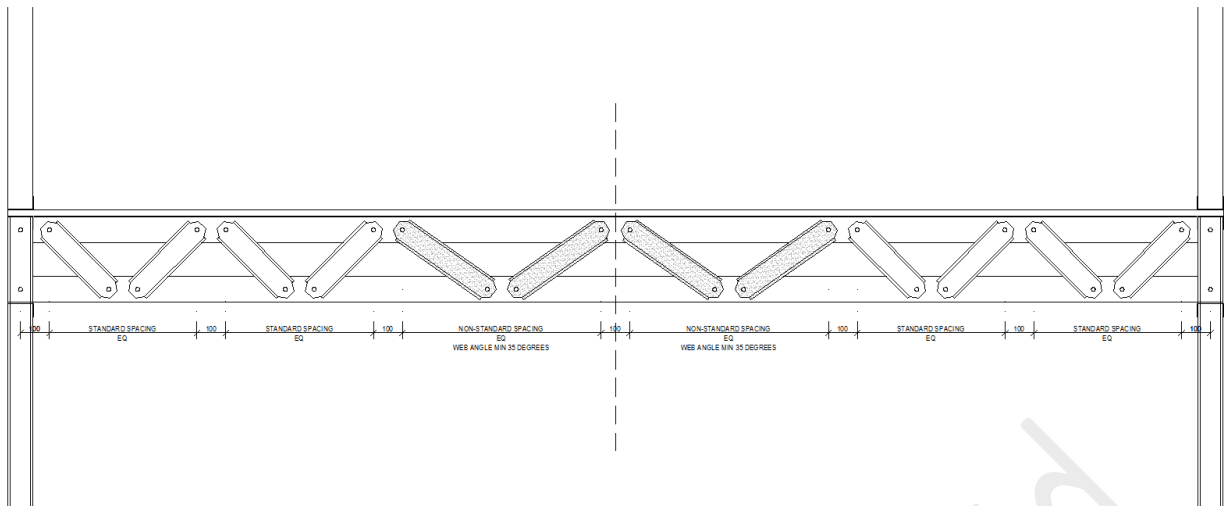

Detail: Typical standard floor truss - middle webs at minimum 35 degrees

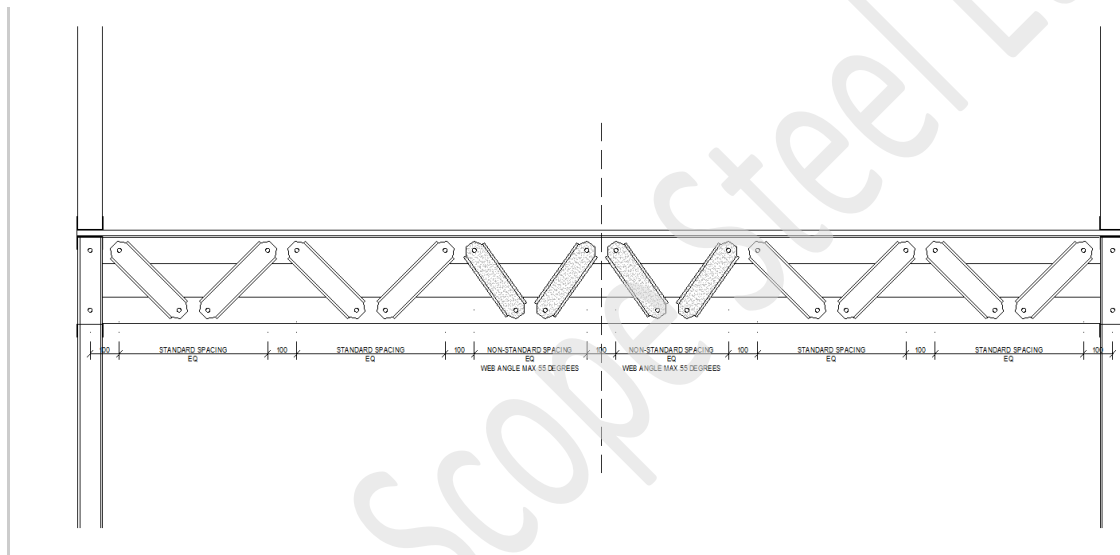

Detail: Typical standard floor truss - middle webs greater than 45 degrees

Design Options

The following options for standard floor trusses include:-

- Top chord section (where specified, the 2 vertical chords at the end of the truss shall be the same section)
- Single or boxed top chord section
- Bottom chord section.
- Single or boxed bottom chord section
- Web section. This also applies to any vertical sections above a load bearing wall.
- Truss depth (this shall be from 250mm, 300mm, 350mm, 400mm and 450mm)

All chords have square end cuts. All floor trusses have the webs back-to-back with the chords. The configurations for standard floor trusses are shown below.

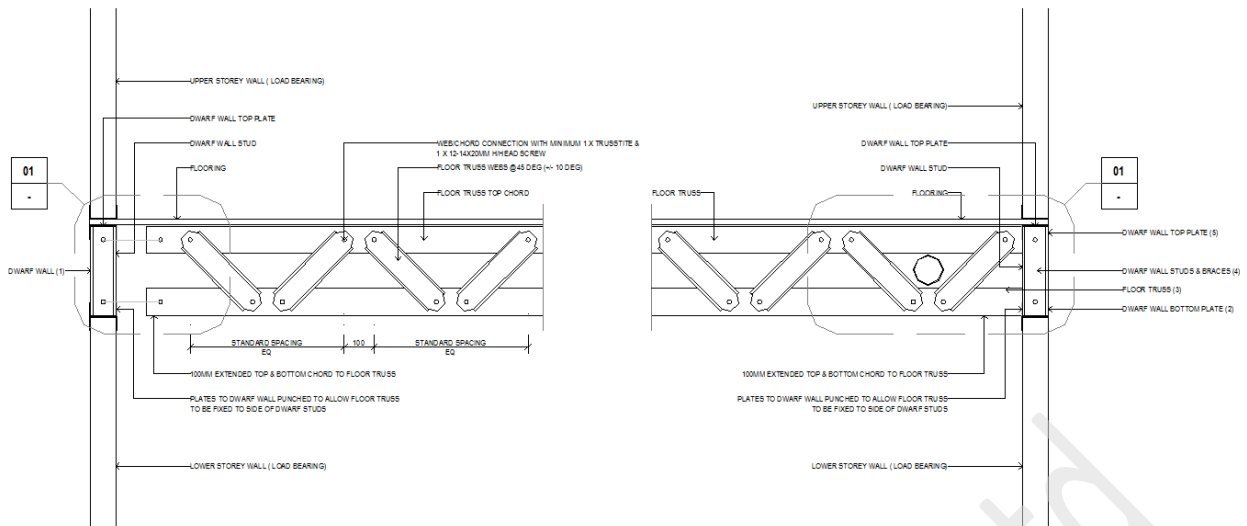

Detail: Typical standard floor truss - Context and components

The end connection detail of a standard floor truss is shown in Figure 10 3 Typical standard floor truss end connection detail. The standard truss fits into and connects with Trusstite screws to the end wall which is manufactured separately to the standard floor truss.

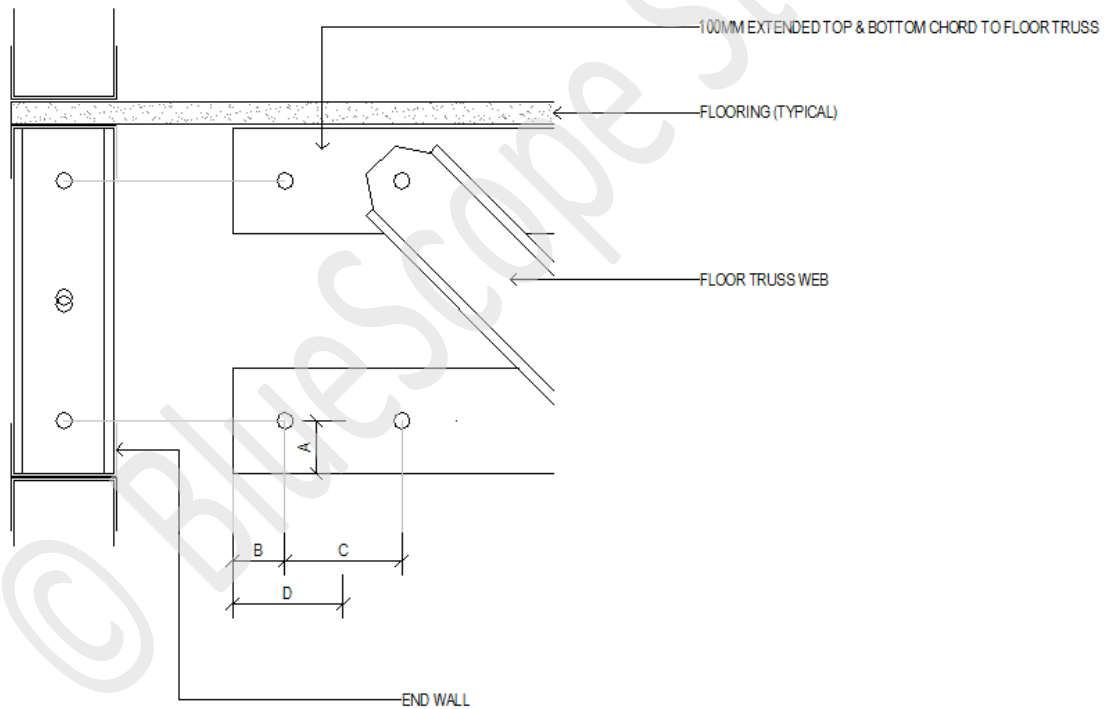

Detail: End connection punch locations

Handling of Endurofloor trusses

Trusses must be fully supported in either horizontal or vertical planes when being transported. Care must be taken when tying down and lifting trusses not to put an excessive pressure on chords, webs or joints. An additional screw may be inserted to provide additional structural stiffness and ease of transportation.

Most floor trusses work may be lifted by hand, however where craneage is required, use slings. Slings should be located at equal

distances from truss centrelines, and be approximately one-third to one-half the truss length apart.

The angle between the sling legs should be 60 degrees or less and where truss spans are greater than 9000 mm, a spreader bar with suitable attachments at the web-chord connection should be used.

Note: When maneuvering any materials by hand, take care not to damage components. Components should be inspected on arrival to site. Damaged components may affect structural integrity and may require replacement.





Floor trusses exposure and storage

Where trusses are stored on site, they should be blocked above firm ground so that they do not come into contact with the soil and to protect them from ground water:

1. If the trusses are stored horizontally, as shown in Fig. x.x, the blocking should be at 2.0m to 2.5m centres or as required at joints, to prevent bending of the trusses. Avoid using copper, chemically treated timber or EPDM based materials as blocking.
2. If the trusses are stored vertically as shown in Fig. x.x, they should be supported at the designed support locations or bottom chord panel points, and in a manner that will be prevented from tipping or toppling.
3. The truss chords should be sloped such that water drains off.

(SC - insert images)

Truss identification

A summary of the description of floor trusses is shown in the image below. Wall have been removed in the attached image for clarity.

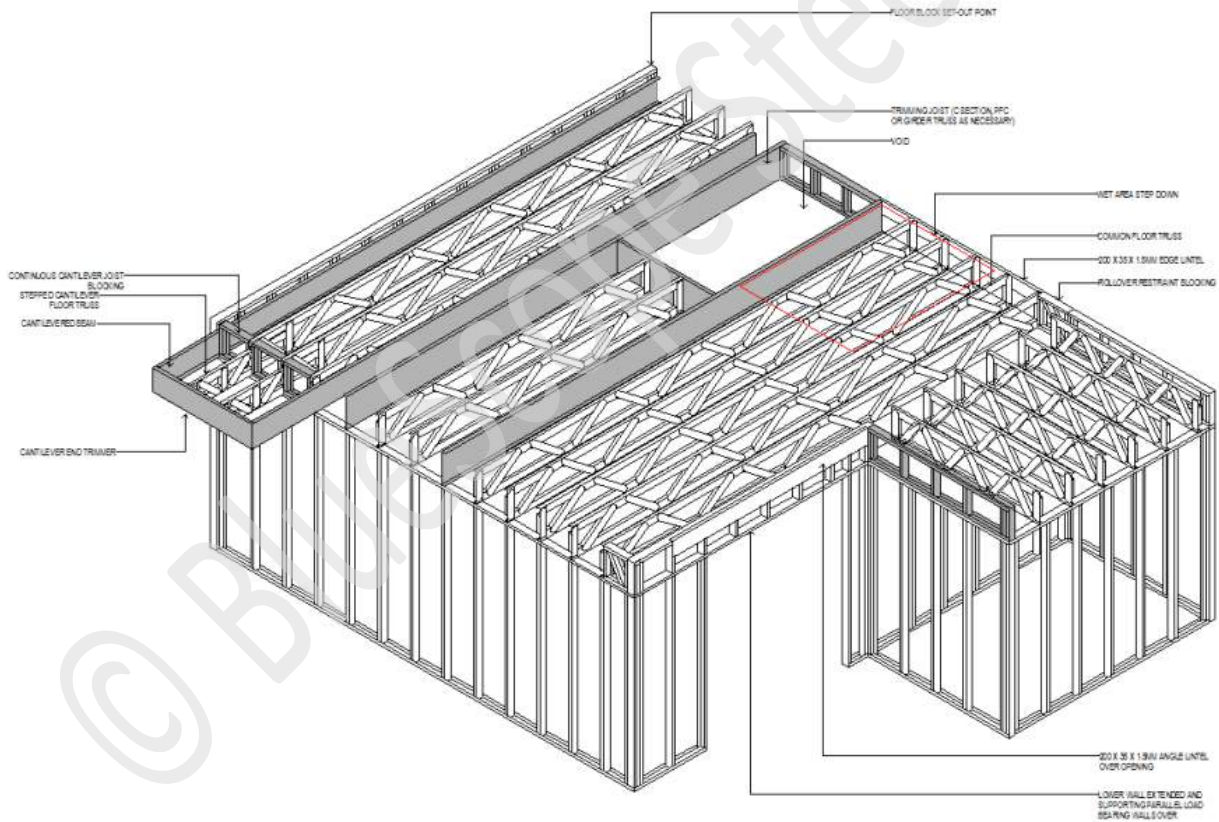

Detail: Typical floor

Standard Floor truss

A standard floor truss consists of parallel top and bottom chords that may be boxed (if necessary), and common webs.

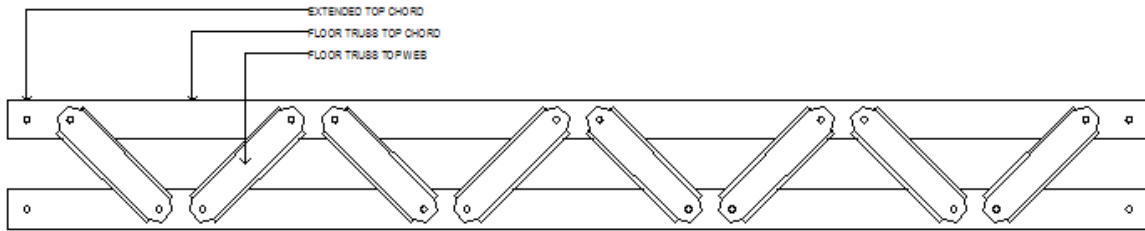

Detail: Standard floor truss

Stepdown Truss

A stepdown truss is used where a reduced top level is required in a wet area such as a bathroom or laundry. Due consideration should be given for the possibility of increased floor dead loads from reinforced mortar bed tiling. Stepdown trusses can also be used on external deck areas or as an architectural feature in alternate floor levels.

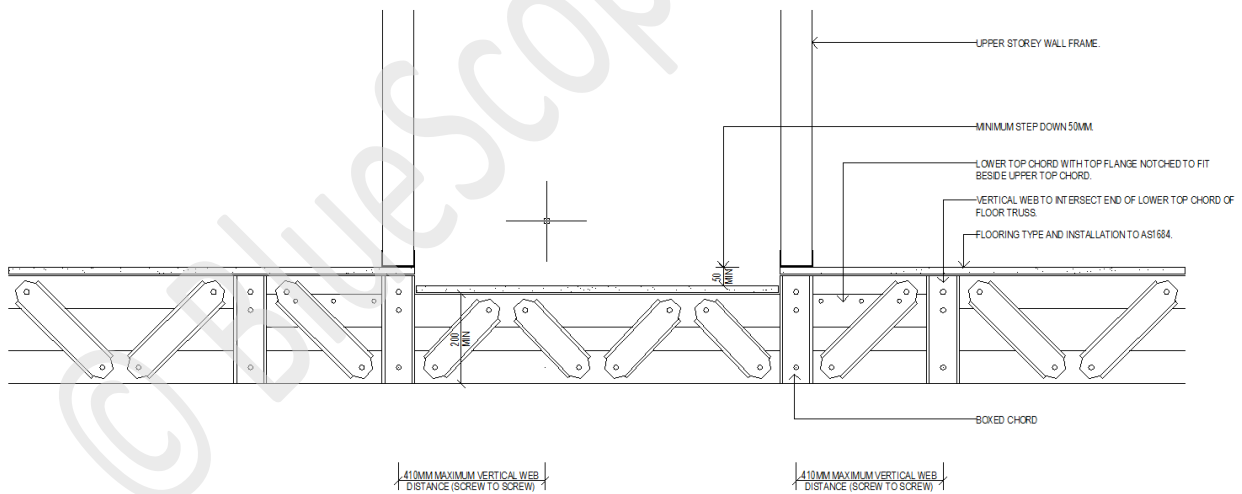

Detail: Stepdown truss

Cantilever Floor Truss

A cantilevered floor truss is used where the span of the truss is required to be extended beyond the supporting wall (or beam) below.

This may also incorporate a *stepdown* to facilitate a difference in level for rainwater drainage. Note: the truss is not self supporting and requires a support beam system tied back to the main structure.

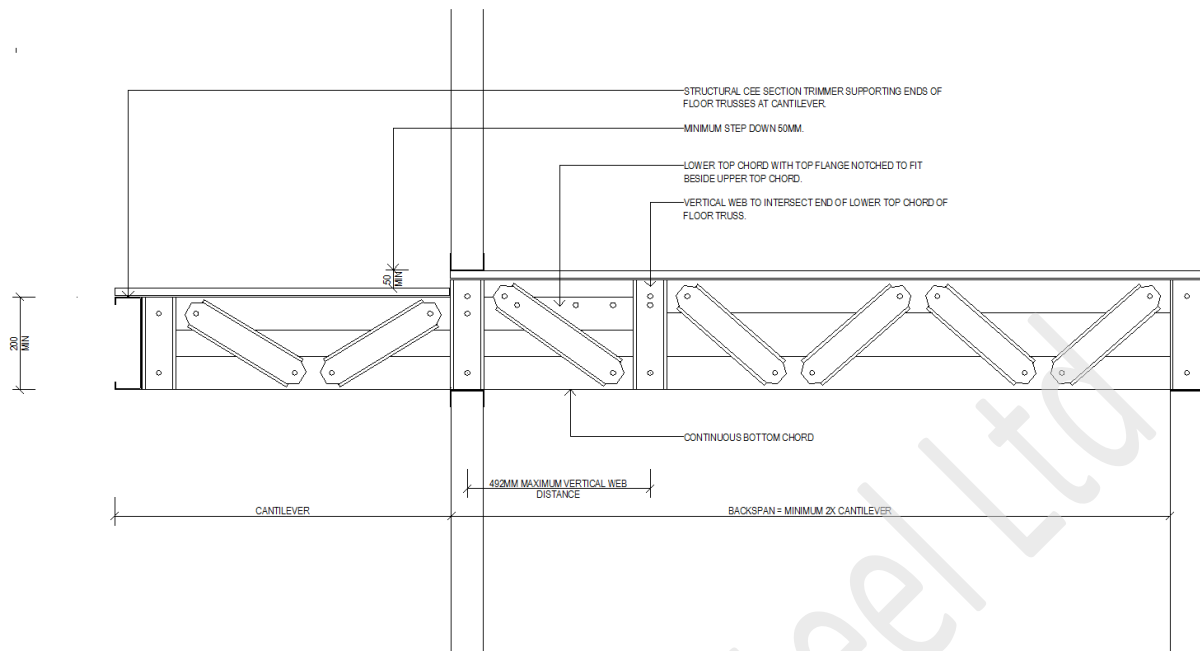

Detail: Cantilever area truss

Truss Assembly

ENDUROFLOOR™ Floor Framing System marking and branding

All ENDUROFLOOR™ Floor Framing System parts are coded with information to assist erectors in the assembly process. This matches the part information shown on the assembly drawings.

All ENDUROFLOOR™ Floor Framing System chords, where they are long enough, are coded with the following:

- Part Number, Floor Truss Number, Job Name/Number, Part Length, and Part Usage.
- They also contain the rollformer number and date of manufacture for traceability purposes.

ENDUROFLOOR™ webs are marked with the truss number and the part number.

With this information, installers can identify what the part is and where it is intended to be used in the structure. The illustration below shows how the coding works:

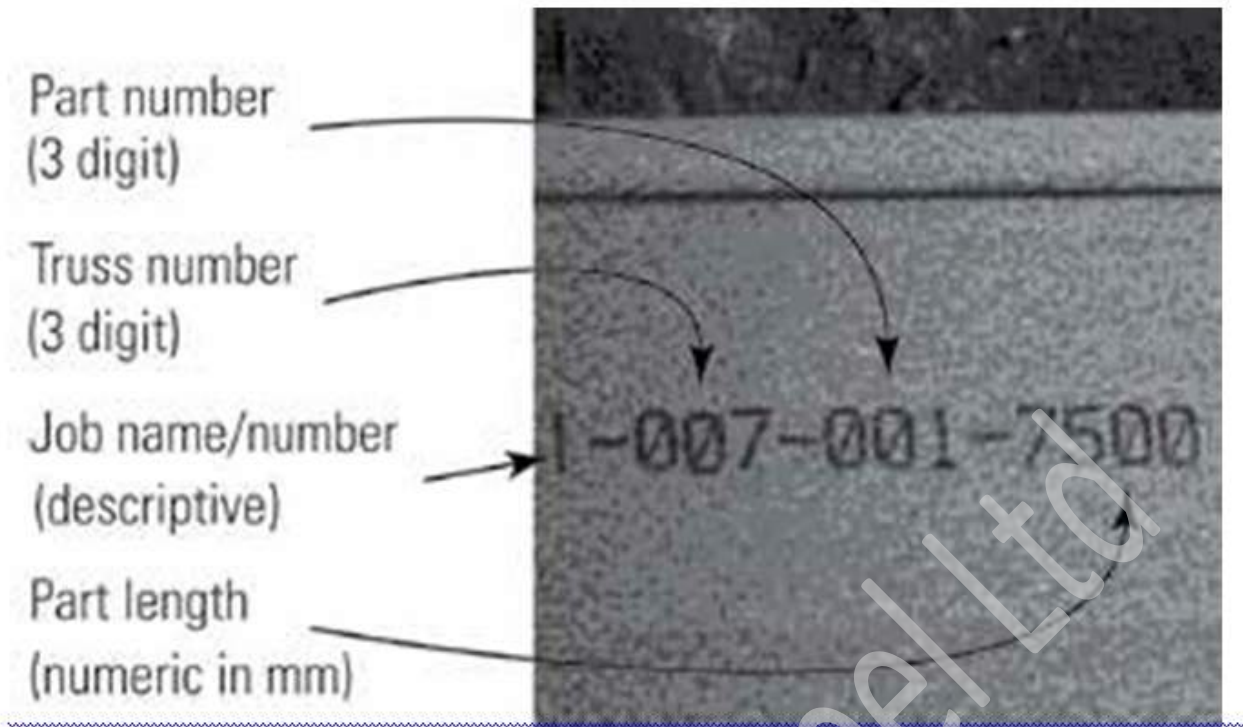

The example above illustrates that this member is for Job Number 1, it is part of floor truss number 7 (as numbered by the software in the construction drawings), it is part number 1 and is 7500mm in length.

Chord to chord connection identification

The connection information is displayed at the top right of the ENDUROCAD® software generated fabrication sheet showing all the connections used in the specific floor truss. Unless specified, this number applies to all connections on the floor truss. All chords must be assembled with at least a single Trusstite and a single 12-14x20 hex head reinforcement fastener.

Connections

The number of connections and web lengths used in the ENDUROFLOOR™ floor trusses have been minimised to assist in uniform and simplified construction. Install as shown on the following images.

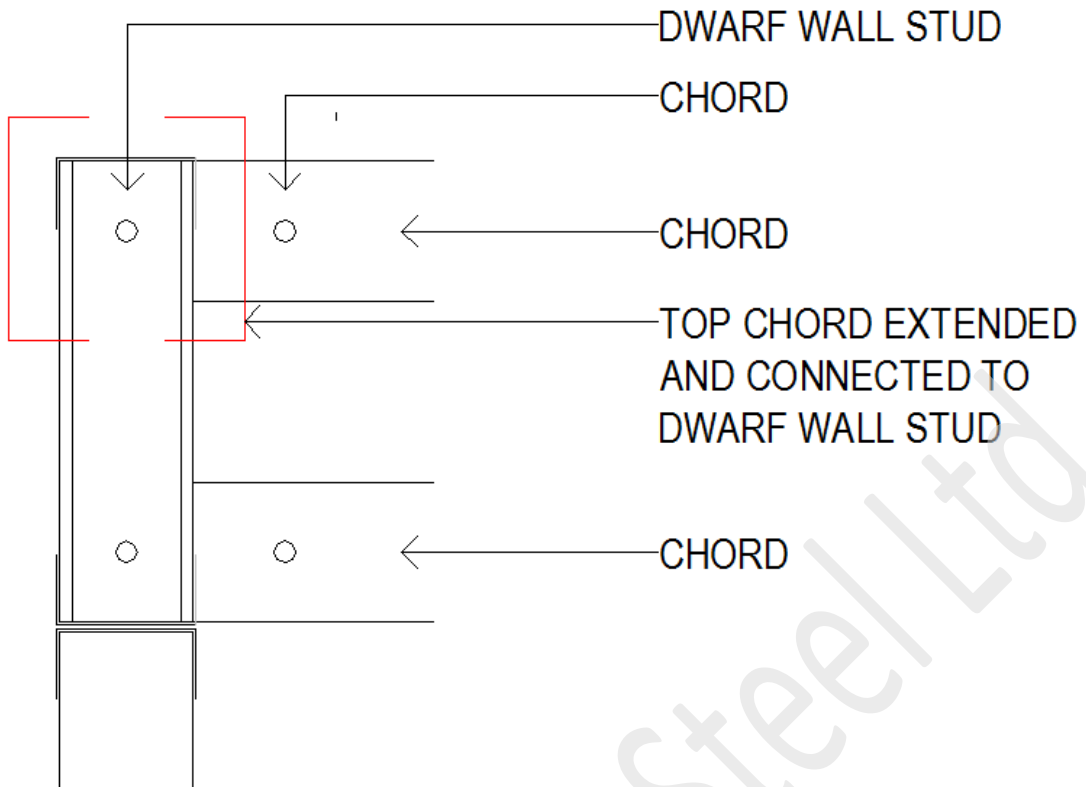

Detail: Floor truss to end wall connection - typical (Independent and Integrated wall types)

© BlueScope Steel Ltd

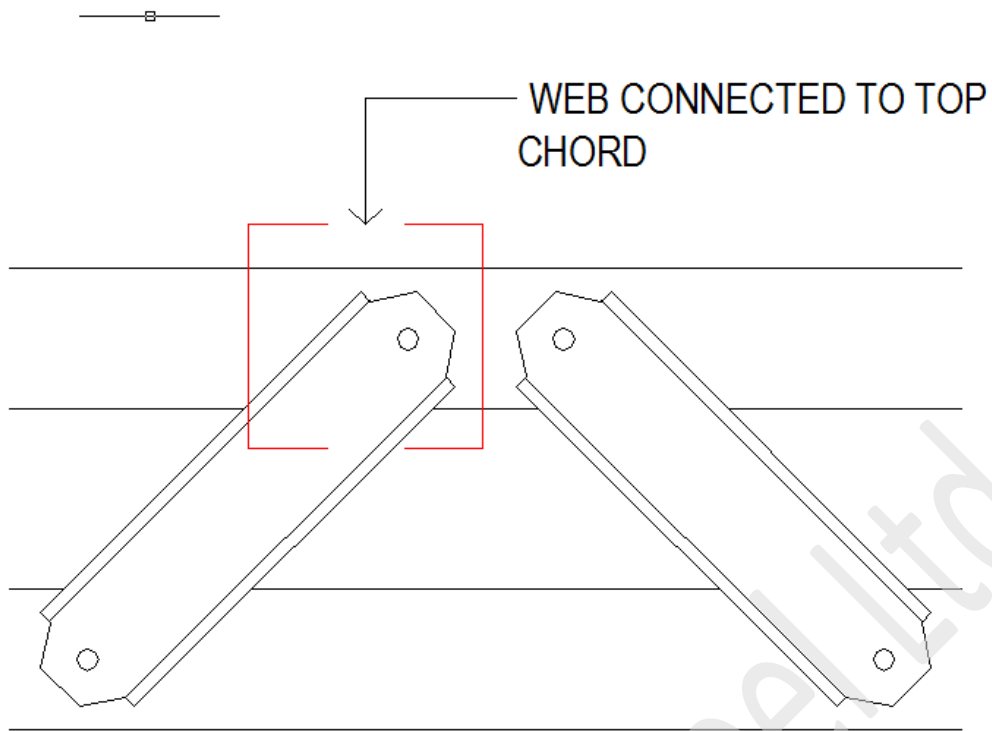

Detail: Typical web to chord connection - typical

In a stepdown truss connection, as illustrated below, three extra screws are to be placed along the face junction of the top chords. One is positioned at the web to chord/chord face and the remaining two placed evenly along the face of the chords.

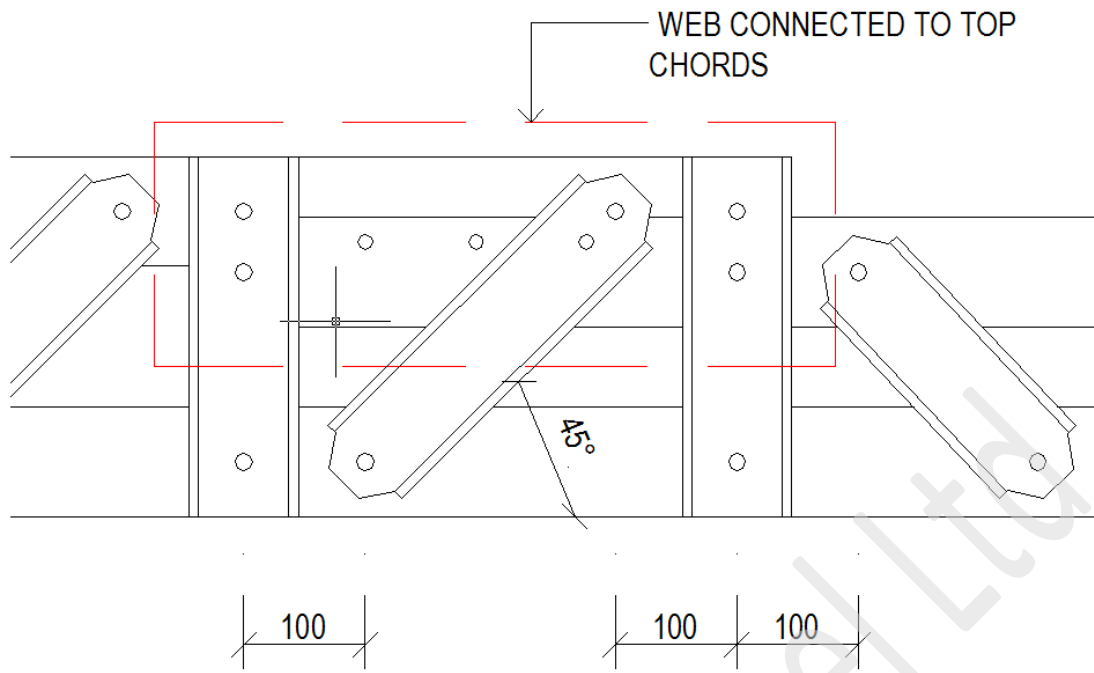

Detail: Stepdown connection - typical

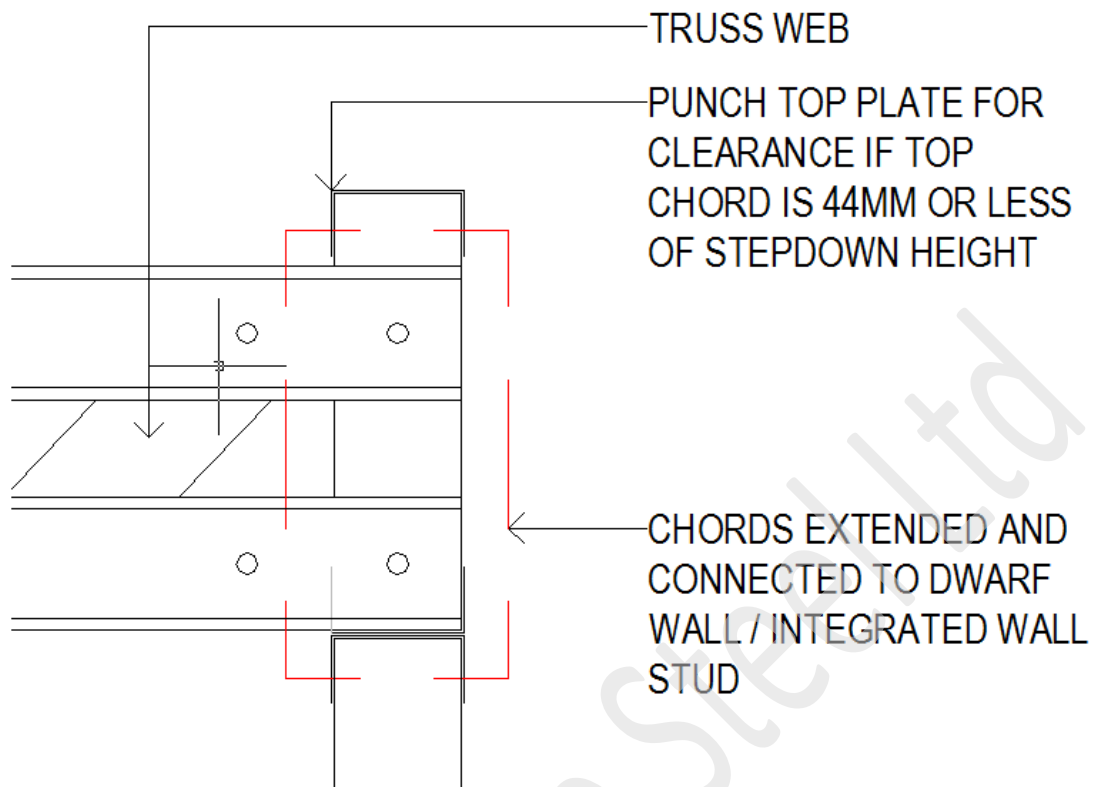

Detail: Stepdown to end wall connection - typical (Independent and Integrated wall types)

Standard Truss Assembly

Step 1 - Part Identification

Unpack the trusses and sort into truss lots using the branding as a guide. Identify the chords and webs from the branding information on the parts. To simplify the assembly process, common webs with a predetermined length are used in the majority of the floor trusses with individual webs allowing for manufacture of different floor truss lengths. Refer to [ENDUROTRUSS® Framing System marking and branding](#) for more information on how to identify parts.

Step 2 - Truss Layout & Chord Assembly

Identify the chords and lay toes down on a level surface or assembly table and align as per assembly drawing. Vertical chords will lay back-to-back with horizontal chords. Pre-punched holes are provided for locating truss screw to connect the chords together. All sections for chords have square cut ends.

Note: Branding is on the side flange which will be on the outside of the truss chords which can aid in assembly and laying out.

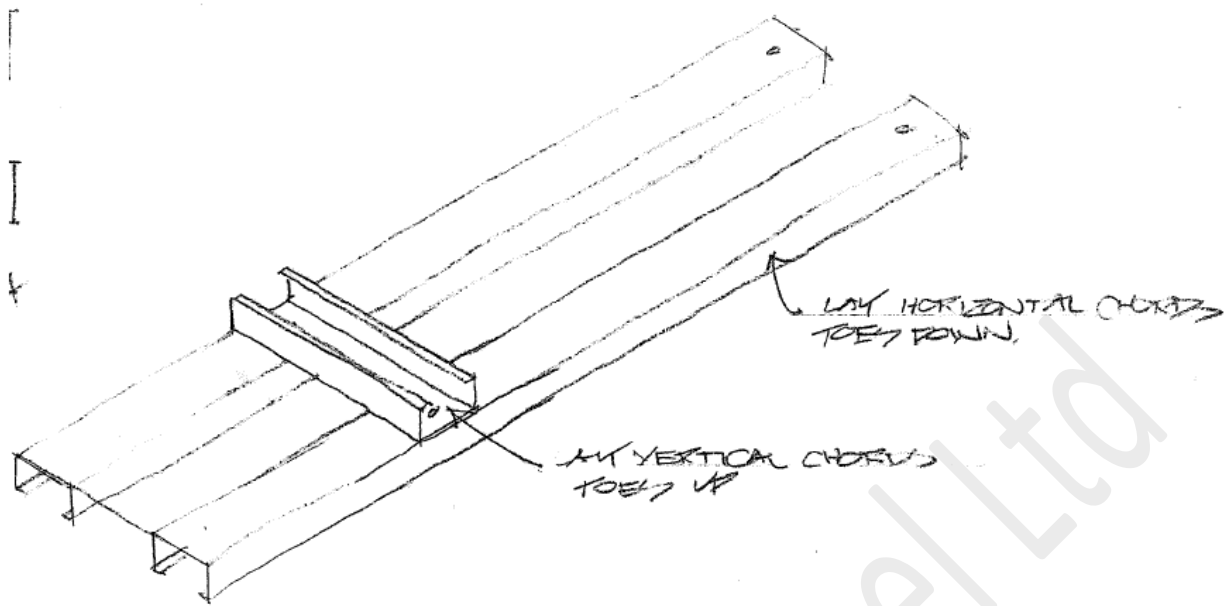

Detail: Initial chord placement

Step 3 - Align holes and install a locating truss screw

When carrying out the primary assembly of the end webs and chords, align holes as shown and install a locating Trusstite screw in holes.

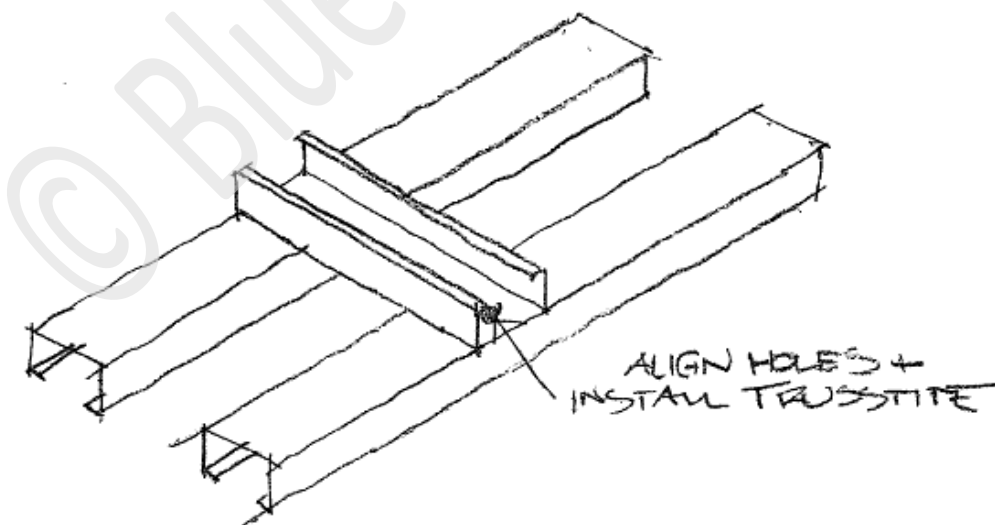

Detail: Hole alignment and trusstite installation

Step 4 - Web Installation

If they are linked together, separate linked webs by cutting or snapping pieces apart. If webs are joined they will be attached in the order required for assembly (Left to right). Snip or snap the webs apart and position each one over the truss chords near their final location. As this is only a non-flush truss the branding on the webs will face towards the top of the truss and toes of the channel will face up and no notches are provided at the web ends.



Detail: Web separation

Step 5 - Align holes and fix connection with a locating truss screw

Using part identifier numbers layout the webs in accordance with the Assembly Sheet. Line up the 6mm locating holes on the ends of the webs with the appropriate holes on the floor truss chords. Install a locating Trusstite[®] screw into the aligned holes ensuring that the screw is driven firmly home and does not strip.

Should the locating truss screw strip, reduce the driver torque and place a 12-24x20mm self drilling screw 20mm minimum from the locating truss screw.

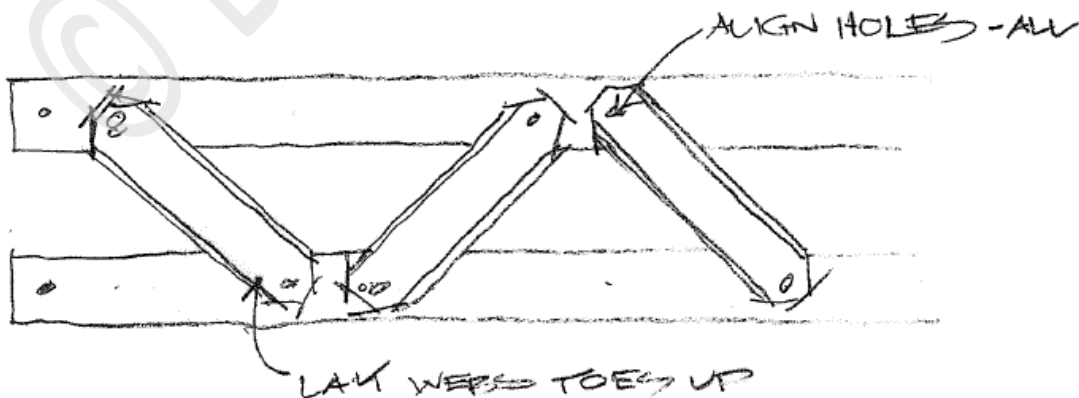

Detail: Web placement

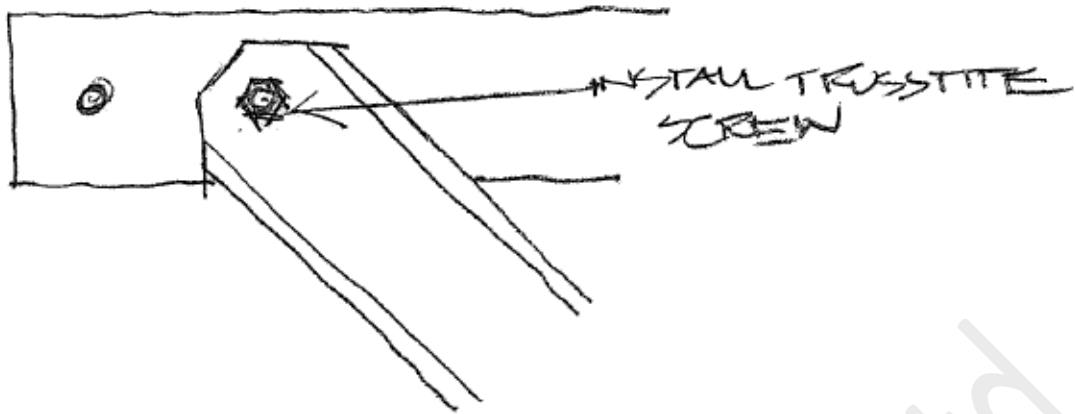

Detail: Web fixing

Step 6 - Check floor truss dimensions and alignment

Before inserting any reinforcing screws check the overall dimensions of the floor truss against the Assembly Sheet. For a complex shape truss, lay it on top of a previously assembled one and check they are the same.

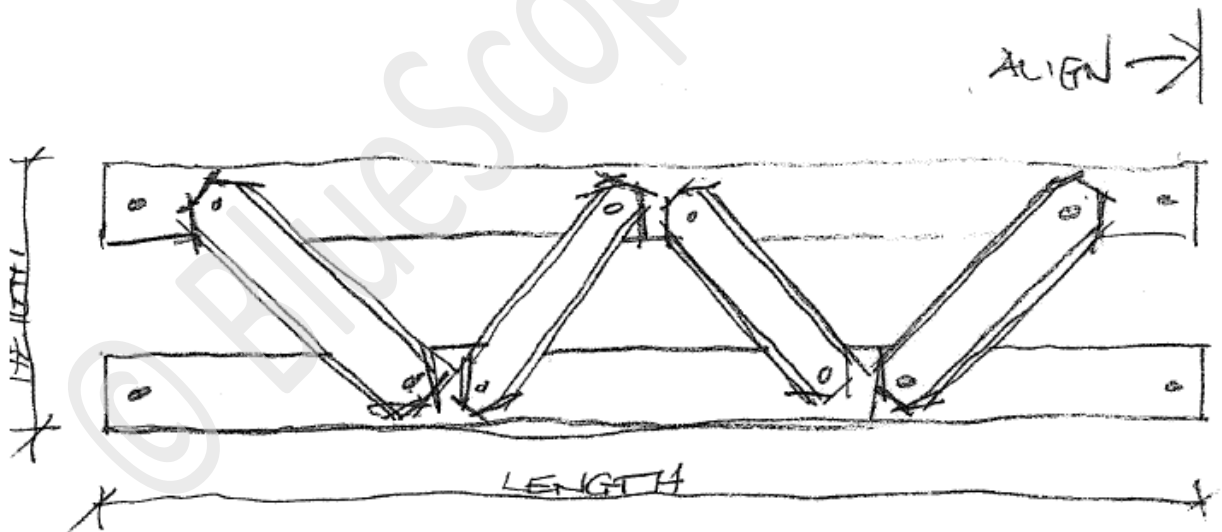

Detail: Check measure

Step 7 - Reinforcement screw installation

Once aligned, install 12-24x20mm hex head screws between the Trusstite fastener and the inside flange of the chord as shown in the detail below.

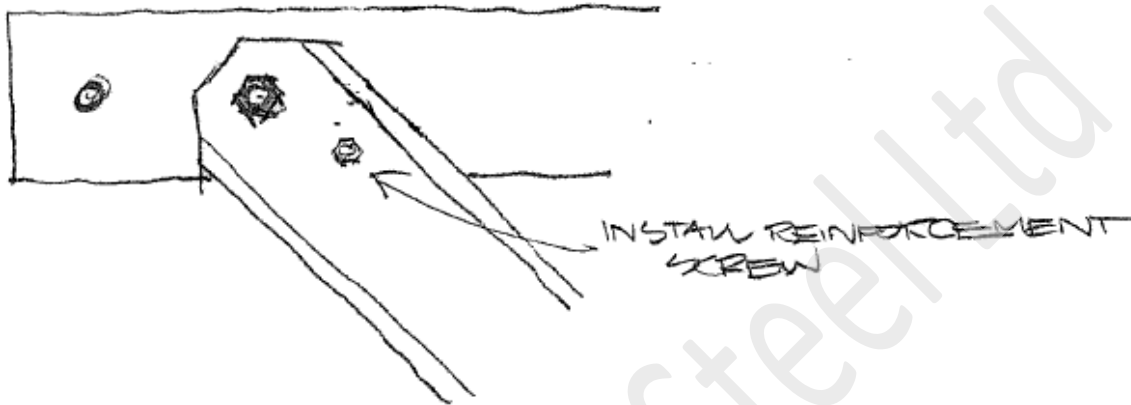

Detail: Reinforcement screw installation

ENDUROFLOOR™ Floor Framing System stiffening and reinforcement

Refer to the ENDUROCAD® software generated connection drawing and the assembly drawings to identify reinforcing screws required to complete truss assembly. Primary fixing screws are self-locating Trusstite® screws fastened through pre-punched holes, while reinforcing screws are #12-14 x 20mm hex-head self-drilling fasteners, without washers. Stiffening screws should be installed a minimum of 21mm from each other and the locating screw and a minimum distance of 10mm from the edge and 17mm from the end.

From the appropriate connection drawing, identify the location and the screws required. Install as shown on the drawing.

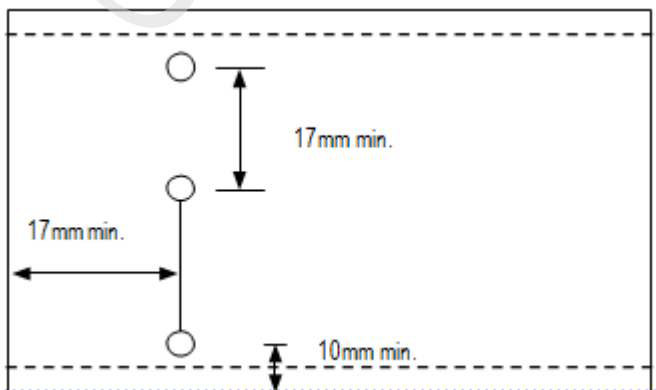

Detail: Screw distances

Web connection stiffening

Identify webs requiring reinforcing screws by referring to the span tables. For example, all web to chord connections require 2 screws which consists of 1 x Trusstite® and 1 x 12/14 x 20mm Hex Head reinforcing screw. This is indicated in the span tables below in white background text. Where grey background is behind the text in the table below, 3 screws are required consisting of 1 x Trusstite® and 2 x 12/14 x 20mm Hex Head reinforcing screw.

Maximum Joist Spans for Domestic Floors – Dead Load 0.6 kPa Live Load 1.5 kPa

Joist Depth (mm)	Section	JOIST SPACING					
		450mm			600mm		
		TCx1, BCx1	TCx2, BCx1	TCx2, BCx2	TCx1, BCx1	TCx2, BCx1	TCx2, BCx2
250	C7575ra	3200	3800	4300	2900	3200	3900
	C7510ra	3800	4200	4700	3200	3800	4300
	C9075ra	3100	3800	4300	2800	3200	3900
	C9010ra	3700	4100	4700	3100	3800	4300
	C9012ra	4000	4400	5000	3600	4000	4500
300	C7575ra	4000	4400	5100	3700	4000	4600
	C7510ra	4400	4900	5500	4000	4400	5100
	C9075ra	4000	4400	5000	3600	4000	4600
	C9010ra	4400	4800	5500	4000	4400	5000
	C9012ra	4700	5100	5800	4300	4700	5300
350	C7575ra	4600	5000	5700	4200	4600	5200
	C7510ra	5000	5500	6200	4600	5000	5700
	C9075ra	4600	5000	5700	4200	4600	5200
	C9010ra	5000	5500	6200	4600	5000	5700
	C9012ra	5300	5800	6500	4900	5300	6000
400	C7575ra	5100	5600	6300	4600	5100	5800
	C7510ra	5600	6100	6700	5100	5600	6300
	C9075ra	5100	5600	6300	4700	5100	5800
	C9010ra	5600	6100	6700	5100	5600	6300
	C9012ra	5900	6400	7000	5400	6000	6600
450	C7575ra	5600	6100	6700	5100	5600	6300
	C7510ra	6100	6500	7200	5600	6100	6700
	C9075ra	5600	6100	6800	5100	5600	6300
	C9010ra	6100	6600	7200	5600	6100	6800
	C9012ra	6400	6800	7500	6000	6400	7100

Notes:

1. TCx1 & BCx1 - single top chord & single bottom chord
2. TCx2 & BCx2 - Boxed top chord & boxed bottom chord
3. Minimum 2-screw per connection
4. Minimum 0.75 thick webs

5. (grey shading) means 3-screws per connection is required (1 x Trusstite® and 2 x 12/14 x 20mm Hex Head reinforcing screw)

Maximum Joist Spans for Domestic Floors – Dead Load 1.0 kPa Live Load 1.5 kPa

		JOIST SPACING					
		450mm			600mm		
Joist Depth (mm)	Section	TCx1, BCx1	TCx2, BCx1	TCx2, BCx2	TCx1, BCx1	TCx2, BCx1	TCx2, BCx2
250	C7575ra	3000	3600	4100	2700	3000	3700
	C7510ra	3600	3900	4500	3000	3600	4100
	C9075ra	3000	3600	4100	2700	3000	3700
	C9010ra	3200	3900	4400	3000	3600	4100
	C9012ra	3800	4200	4700	3100	3800	4300
300	C7575ra	3800	4200	4800	3200	3800	4400
	C7510ra	4200	4600	5200	3800	4200	4800
	C9075ra	3800	4200	4800	3200	3800	4300
	C9010ra	4200	4600	5200	3800	4200	4800
	C9012ra	4400	4900	5500	4000	4400	5000
350	C7575ra	4300	4800	5400	3900	4300	4900
	C7510ra	4700	5200	5900	4300	4800	5400
	C9075ra	4300	4800	5400	3900	4300	4900
	C9010ra	4700	5200	5800	4300	4800	5400
	C9012ra	5000	5500	6100	4600	5000	5700
400	C7575ra	4800	5300	6000	4400	4800	5500
	C7510ra	5300	5800	6400	4800	5300	6000
	C9075ra	4800	5300	6000	4400	4800	5500
	C9010ra	5300	5800	6400	4800	5300	6000
	C9012ra	5600	6000	6600	5100	5600	6200
450	C7575ra	5300	5800	6400	4800	5300	6000
	C7510ra	5800	6200	6800	5300	5800	6400
	C9075ra	5300	5800	6400	4800	5300	6000
	C9010ra	5800	6200	6800	5300	5800	6400
	C9012ra	6100	6500	7100	5600	6100	6700

Notes:

1. TCx1 & BCx1 - single top chord & single bottom chord
2. TCx2 & BCx2 - Boxed top chord & boxed bottom chord
3. Minimum 2-screw per connection
4. Minimum 0.75 thick webs
5. (grey shading) means 3-screws per connection is required (1 x Trusstite® and 2 x 12/14 x 20mm Hex Head reinforcing screw)

Chord Boxing

Where called for in the Assembly Sheet, chords are to be boxed using supplied boxing channel. Boxing is to be fixed to the inside flanges of chords using either 10-16 x 16mm hex head self drilling screws, or 12-14 x 20mm hex head self drilling screws as per the

diagram below. These are fixed 50mm from each end of the boxing and at 600 mm nominal centres along the boxing. The top flange of the top chord will be restrained by screws fixing the flooring fixings, and the bottom flanges of the bottom chords are restrained by the ceiling batten fixings.

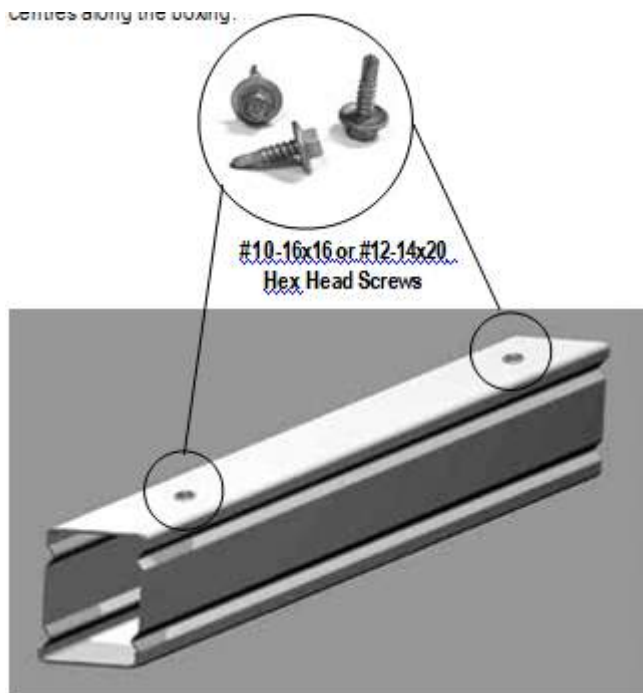

Points for construction

Floor trusses must be installed plumb and straight

While installing the floor, trusses must be fixed plumb and straight. After fixing, if a bow or tilt is evident, the trusses have not been installed correctly. In this case, the problem must be rectified before proceeding further.

THE TRUSSES MUST NOT BE MODIFIED ON SITE WITHOUT FIRST SEEKING ADVICE FROM A TRAINED SOFTWARE USER (TSU) OR SUITABLY QUALIFIED ENGINEER.

Correct direction of ENDUROFLOOR™ chord profile

The direction of the channel section used for the chord should be as depicted on Truss Assembly diagrams in (see Figure X.X.)

Trusses should be oriented as shown on the truss layout drawing provided and ensure load bearing points shown on the assembly drawings align with load bearing walls. Truss chords are inkjet marked to indicate Top Chords - 'TC' - and Bottom Chords - 'BC'. Ensure that trusses are installed in the correct orientation.

DESIGN		QTY
Status	Unknown	2
Approved		

DO NOT ASSEMBLE UNLESS FILLED OUT BY DETAILER

screws EVERY connection
 (1 Trusstite + reinforcing)

EloorBuilder Vers 1.0-0
Endurocadd Vers 9.7.9

PARTS LIST (per joist)					JOIST DETAILS		
DESCRIPTION	No	LEN	MAT	QTY	LENGTH	HEIGHT	WEIGHT
C 7575ra	002	3000	0.750	1	3000	250	9.53
C 7575ra	003	3000	0.750	1			
C 7575ra	010	291	0.750	10	DETAILER	DETAILED	SCALE
C 7575ra	020	232	0.750	2	scarola	22-03-2016	11
TRUSSTITE	-		0	28	Job Number		JOIST
					FLR 160321A		002
					Machine Type	ENDUROTRUSS	
					Fabricator		
					Customer		

Detail: Typical standard floor truss assembly sheet

Straightness

Trusses must be installed with an overall out of plane straightness not greater than $L/500$ where L is the length of the member as shown in the Detail below.

Differential in vertical bows between adjacent members must not exceed $1/150$ of their spacing or 6mm whichever is less.

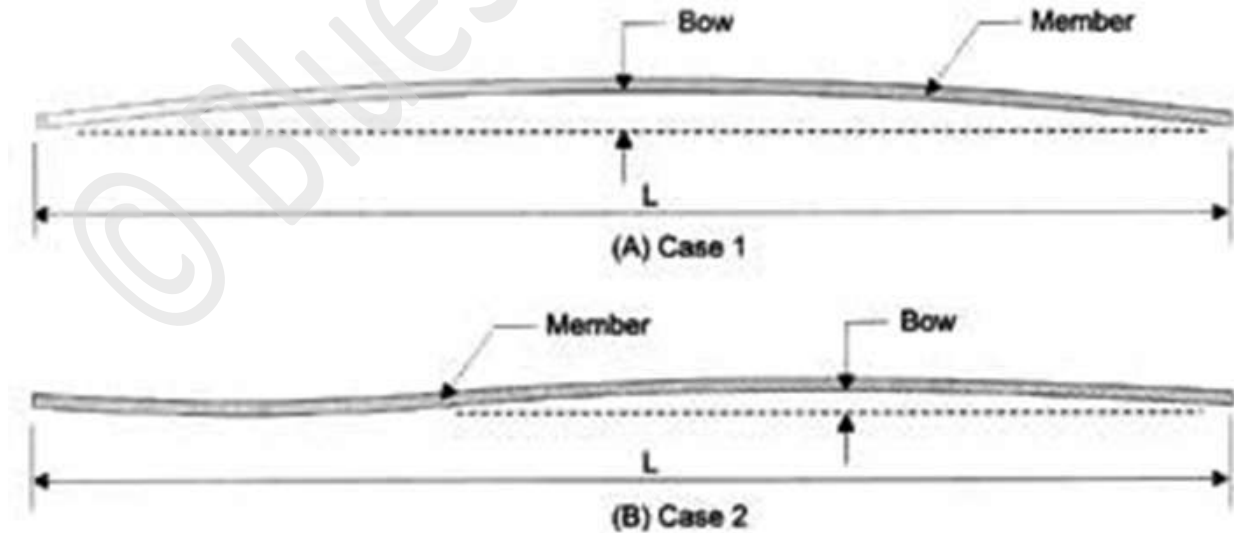

Detail: Straightness

Plumb

Out of plumb at any point along the length of the truss from top to bottom must not exceed the minimum of $h/100$ or 20mm.

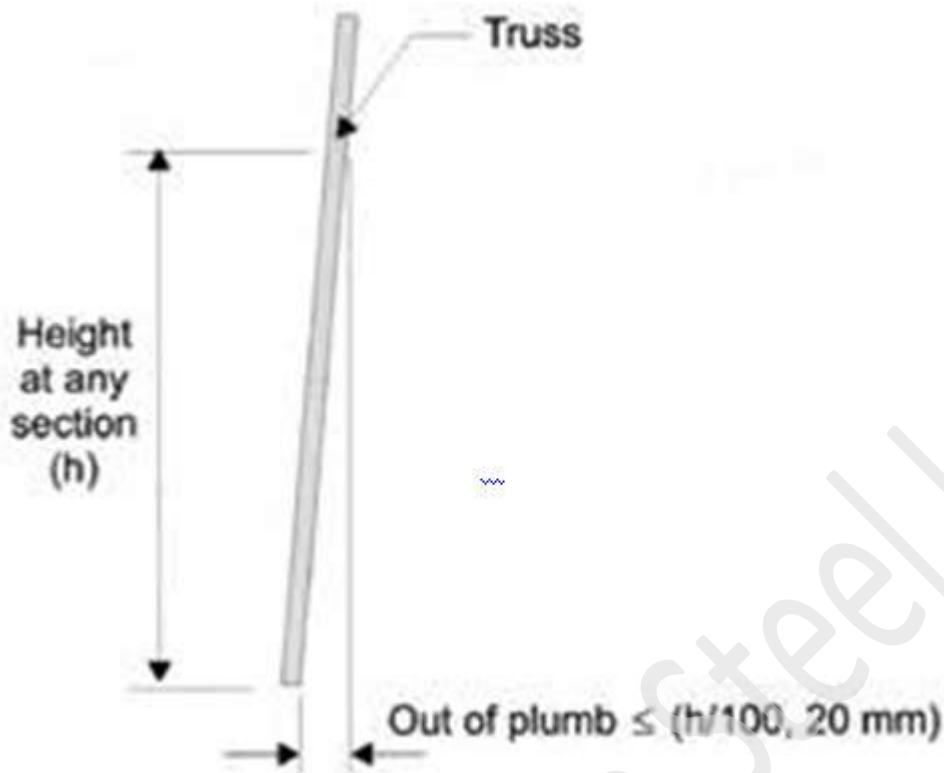

Detail: Plumb

Floor Construction

General and design

ENDUROFLOOR™ system floor trusses have been designed to engineering standards and it is essential that to perform as designed, they are handled, erected and braced correctly. The following recommendations apply to floor trusses on standard domestic buildings.

The trusses are designed by the ENDUROCAD® design software to suit the specific floor geometry and loads applicable to the site conditions. Additional loading such as spa baths, billiard tables, heavy fixed cabinetry etc. require special consideration at the time of design and the placing of these additional loads must be referred back to the designer.

Prior to construction

Before commencing floor construction:

- Check the support structure in particular the plan dimensions, the plumb and level of the support structure, the straightness of the supporting walls or beams and that the structure is adequately braced, stable and tied down. Rectify support structure if found deficient prior to proceeding.
- Floor trusses must be inspected and any damaged parts must be reported immediately to the manufacturer to ensure correct rectification. Approval for on site rectification must be obtained from the truss manufacturer prior to installation.
- Check that the ENDUROCAD® software generated truss layout matches the building and that all truss set-out dimensions and truss identification marks have been provided.
- Prior to lifting any floor trusses into place, mark out the support beam and floor truss locations on the top wall plate, using the supplied Floor Truss Framing Layout as a reference.
- It is generally best practice to install support beams before proceeding with the installation of standard floor truss runs.
- Whilst installing floor trusses ensure that each floor truss is placed in the correct position, correctly orientated and plumb (using a spirit level).
- If trusses are fixed to the support structure using brackets these are often installed in the marked positions prior to positioning the trusses.
- The floor trusses may be aligned to load bearing studs. In cases where it is not aligned, sufficient capacity shall be provided

- for top plate using lintels or stiffeners.
- Check that design floor truss spacings have not been exceeded.

NOTE:

Truss orientation and Position

The layout drawings specifies the correct floor truss orientation.

The front of the floor truss is the flat (unlipped) face of the floor truss horizontal chords. Looking at the floor truss from this direction identifies the Left and Right hand floor truss ends. Ensure floor trusses are orientated as shown on the floor truss layout, and with chord marked with TC at the top of the truss and BC at the bottom of the truss.

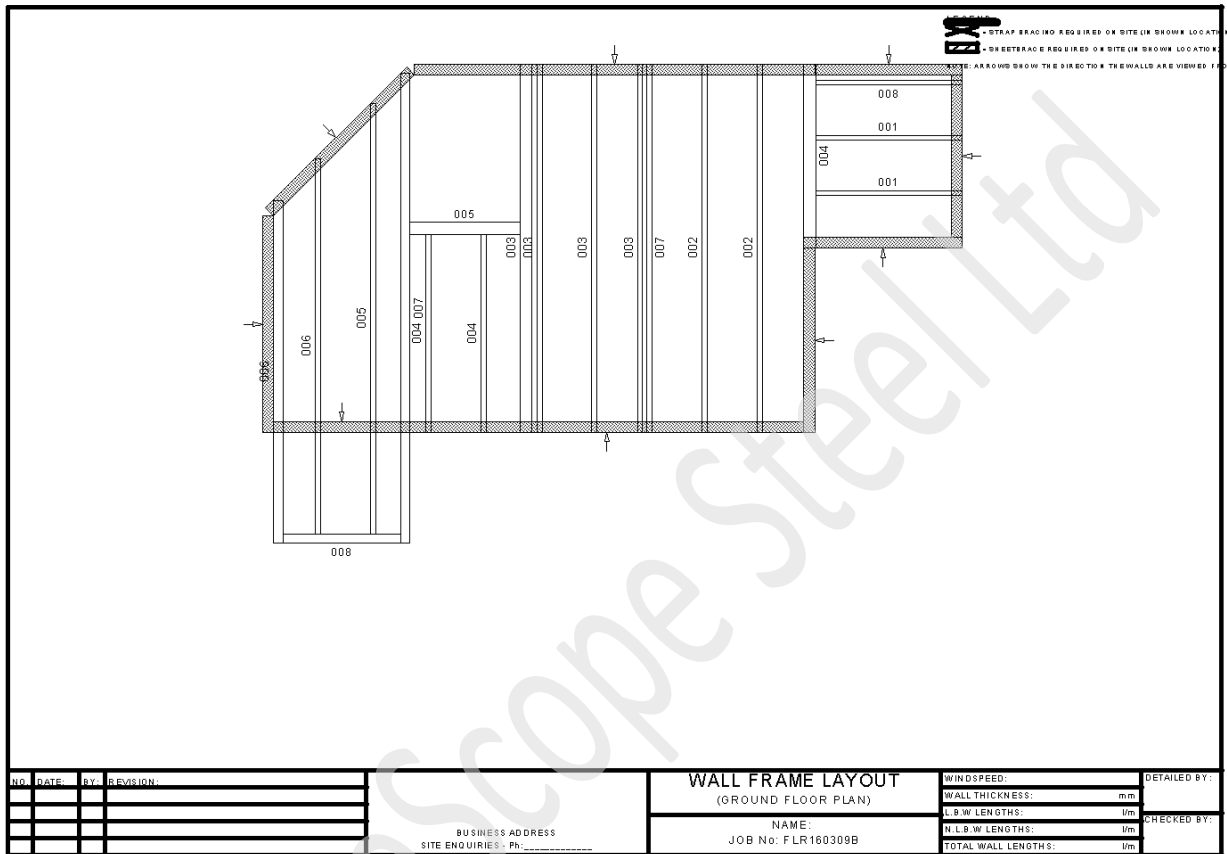

Floor Truss Numbering

During the detailing / fabrication process the floor trusses are numbered to accurately identify them. These numbers are shown on the floor truss layout and form part of the floor truss branding. Floor trusses may have identical shape but may differ in the material used or number of screws in the connections. Ensure that the correct floor truss is used in its specified location in the floor.

Internal load bearing points

Where floor trusses are supported by internal walls, the floor truss web configuration will be designed to satisfy the load concentration at the load bearing point. Ensure that the floor truss is installed such that bottom chord to web connections are within 5mm to the support points. The builder should ensure that these loads are accommodated in the footing design.

Independent wall to floor system

The independent end wall floor system is suitable for either on-site fabrication, or as cassette system in factory pre-fabrication. Both methods are detailed below.

On-site installation

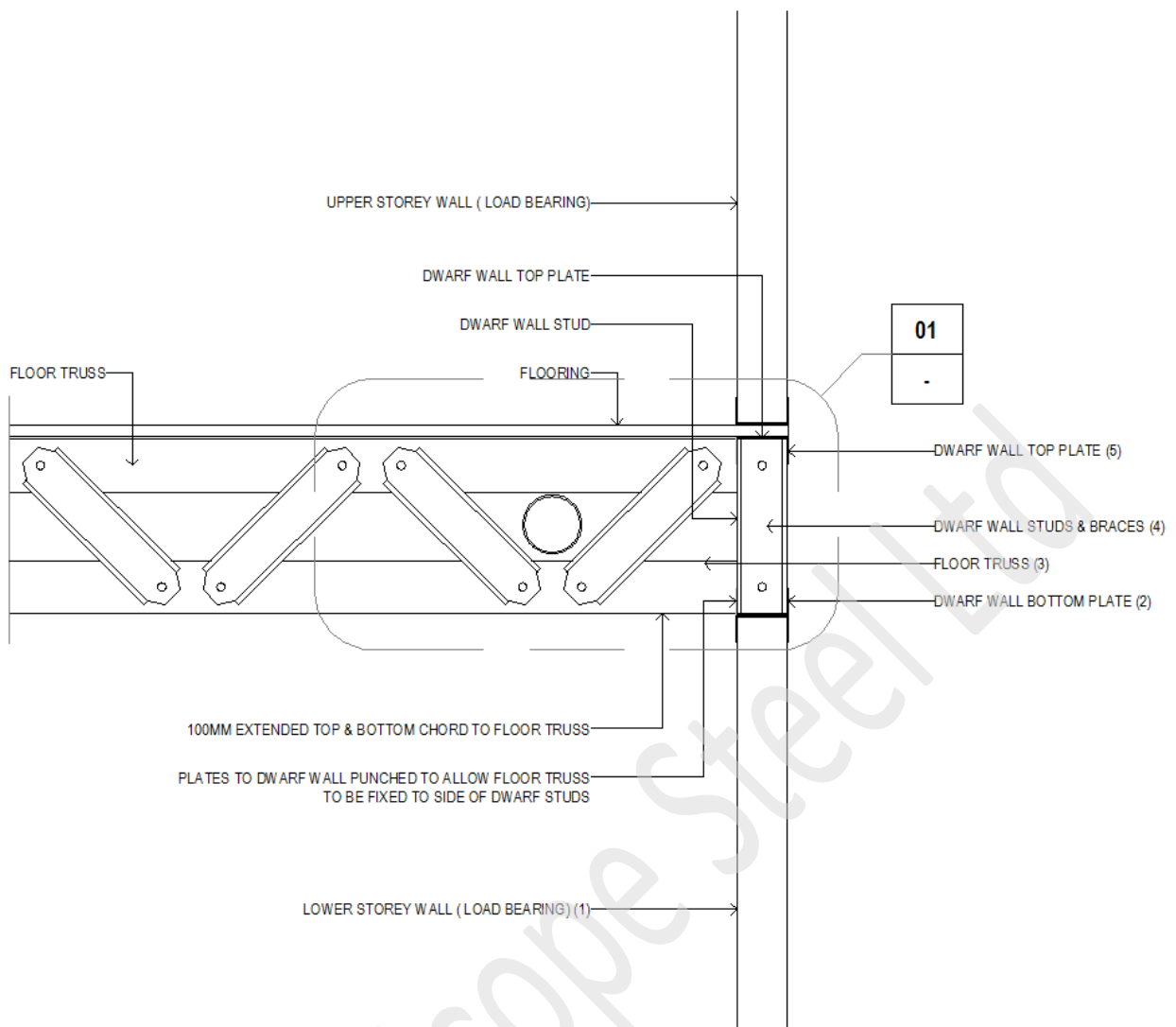

Step 1: Place end dwarf wall bottom plates into position on top of lower storey support walls and beams as indicated by the layout drawings (Ref item: 1 and 2). Note the location of the side flange notches to accommodate for the floor truss and supporting beam positions. Fix to the top plate of the wall below using 1 x 12-14x20 hex head fasteners on either side of the dwarf stud.

End dwarf walls may be supplied to site pre-fabricated. Where this occurs, remove the dwarf wall top plate and install wall in the location defined in the Layout.

Step 2: Lift primary support beams into place as indicated on the layout drawing. If necessary, pack to appropriate height or location as required. Packers may be placed to underside, top or face of the beam to set the correct location and level of the beam for fixing off the floor trusses.

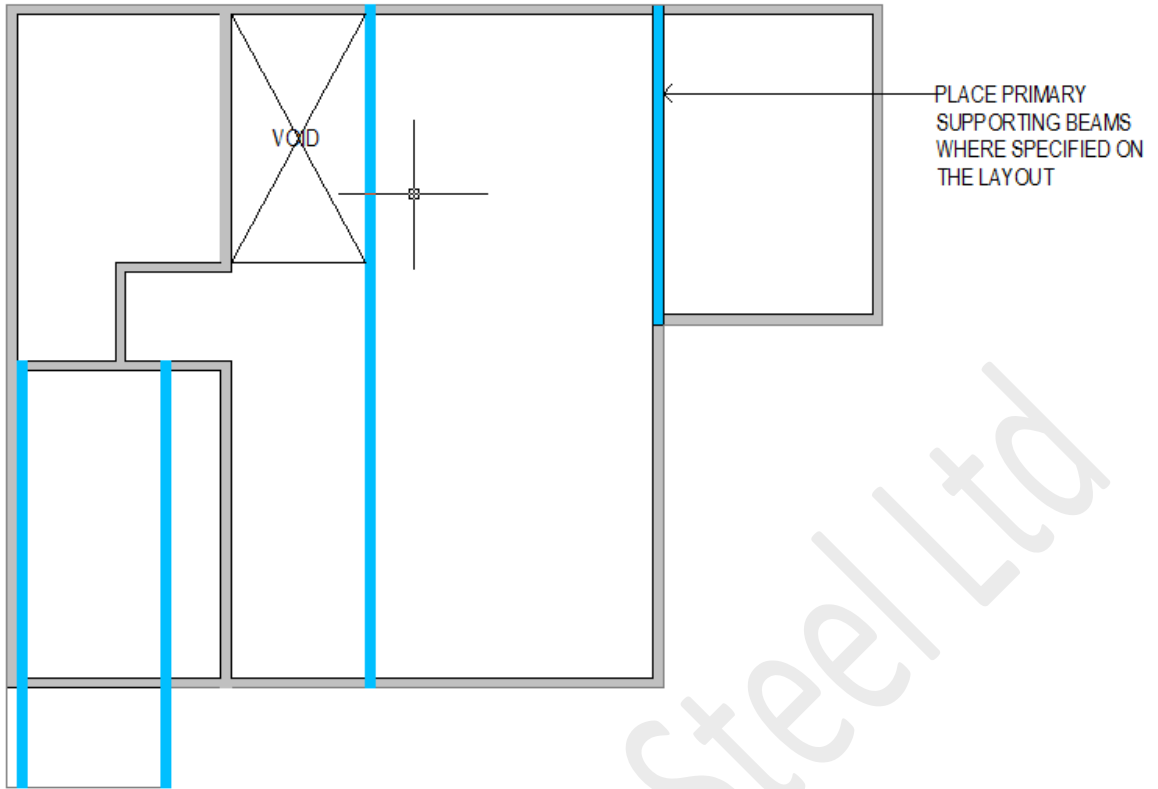





Picture: Packing beams

Step 3: Install connection brackets to primary support beams for all secondary support trimming beams and floor trusses (Note: connection to be specified by suitably qualified engineer or manufacturer). Examples of joist support brackets and their installation is shown below.



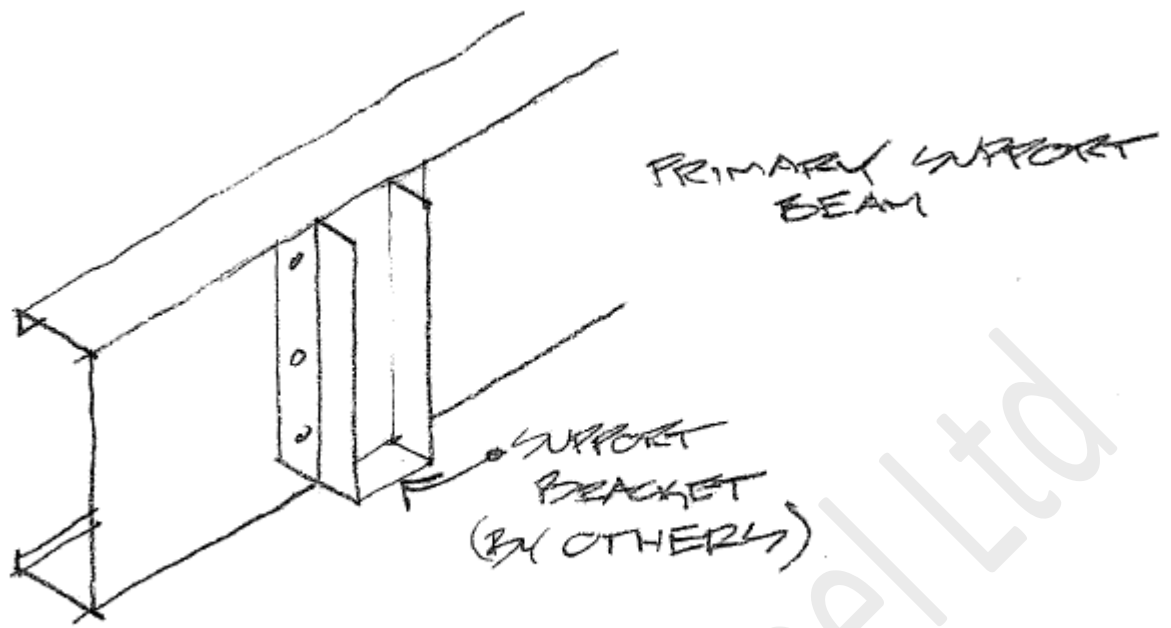



Detail: Locating support brackets

Step 4: Lift secondary support beams into position and fix in place as specified (Note: connection to be specified by suitably qualified engineer or manufacturer).

© BlueScope Steel Ltd

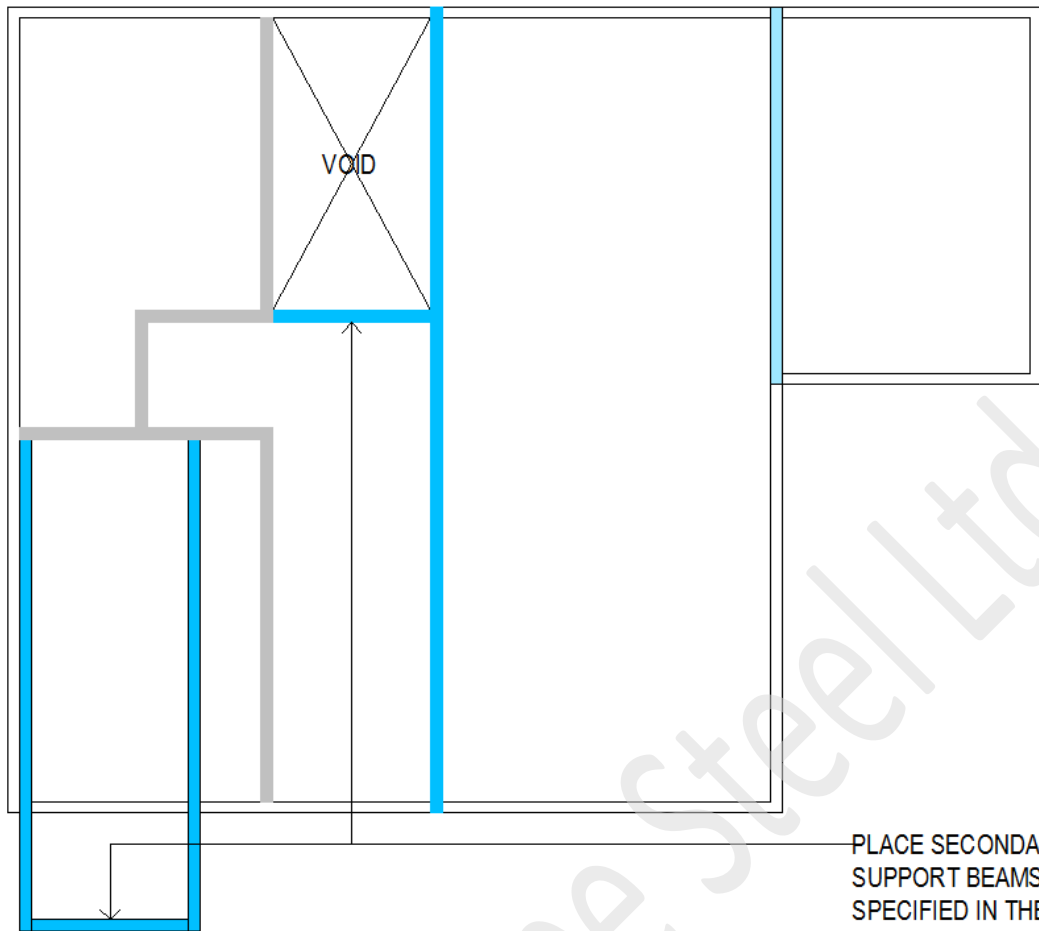

Picture: Fixing Secondary support beams

Step 5: Install connection brackets to secondary support trimming beams for floor trusses (Note: connection to be specified by suitably qualified engineer or manufacturer). This is the same as Step 3.

Step 6: Install end dwarf studs into correct location and fix with 1 x Walltite® screw to both flanges of the bottom plate. (Ref item: 4)

Where the end dwarf wall is pre-fabricated, this step is omitted.

Step 7: Lift floor trusses into place taking note of the direction of the truss in relation to toes left/right and up/down. (Ref item: 3)

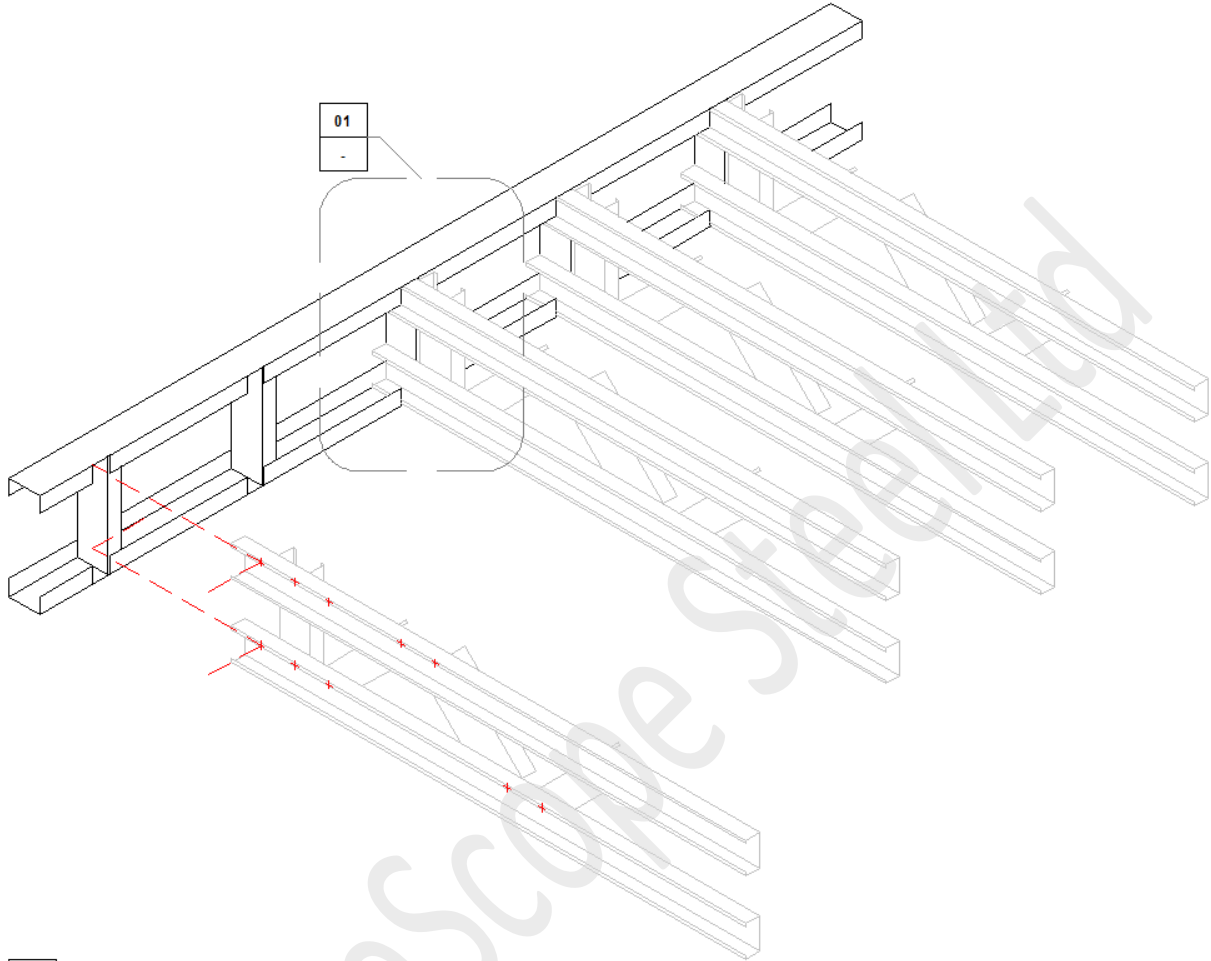

Step 8: Fix floor trusses to side of dwarf wall studs at the pre-punched hole location with 1 x Trusstite® into both the top and bottom chords. Provide reinforcing screws to each chord; the number reinforcing screws will be same as that provided for vertical end web. At support bracket locations insert 2 x 12-14x20 hex head fasteners into both the top and bottom chords.

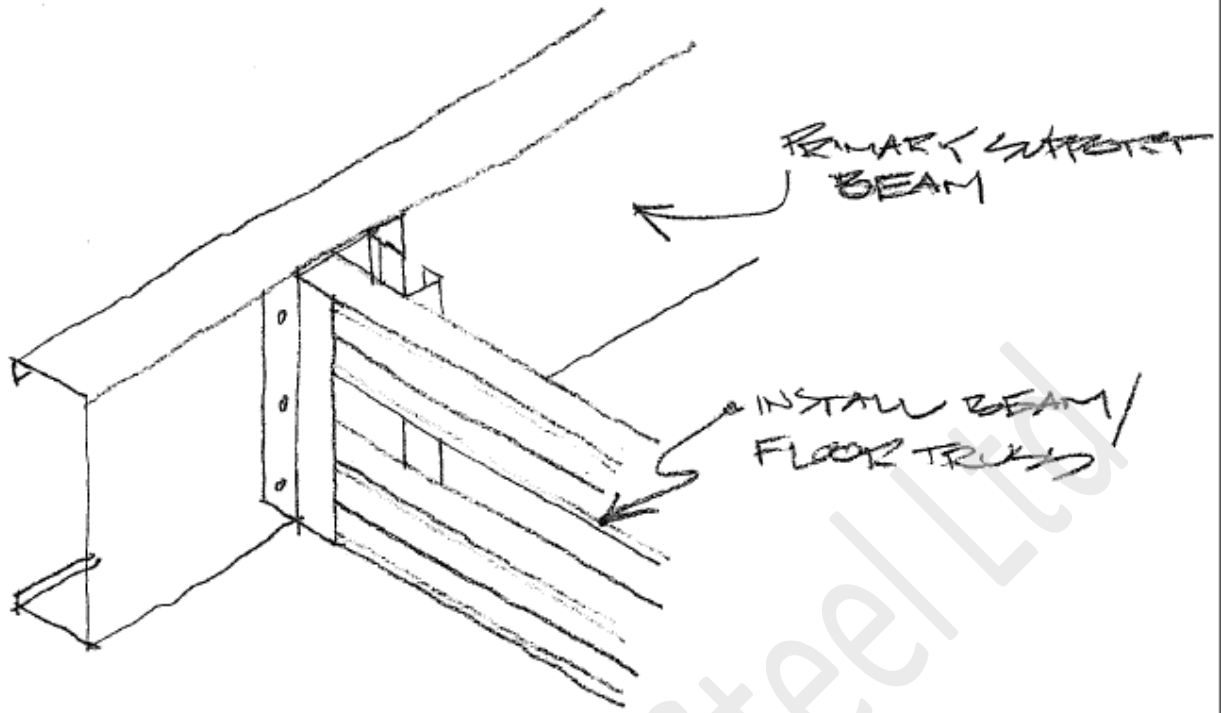

Step 9: Place roll-over restraint (angle stud) at locations defined in the layout and fix with 1 x Walltite® screw to each side of bottom plate. Maximum angle stud spacing is 1800mm c/c.

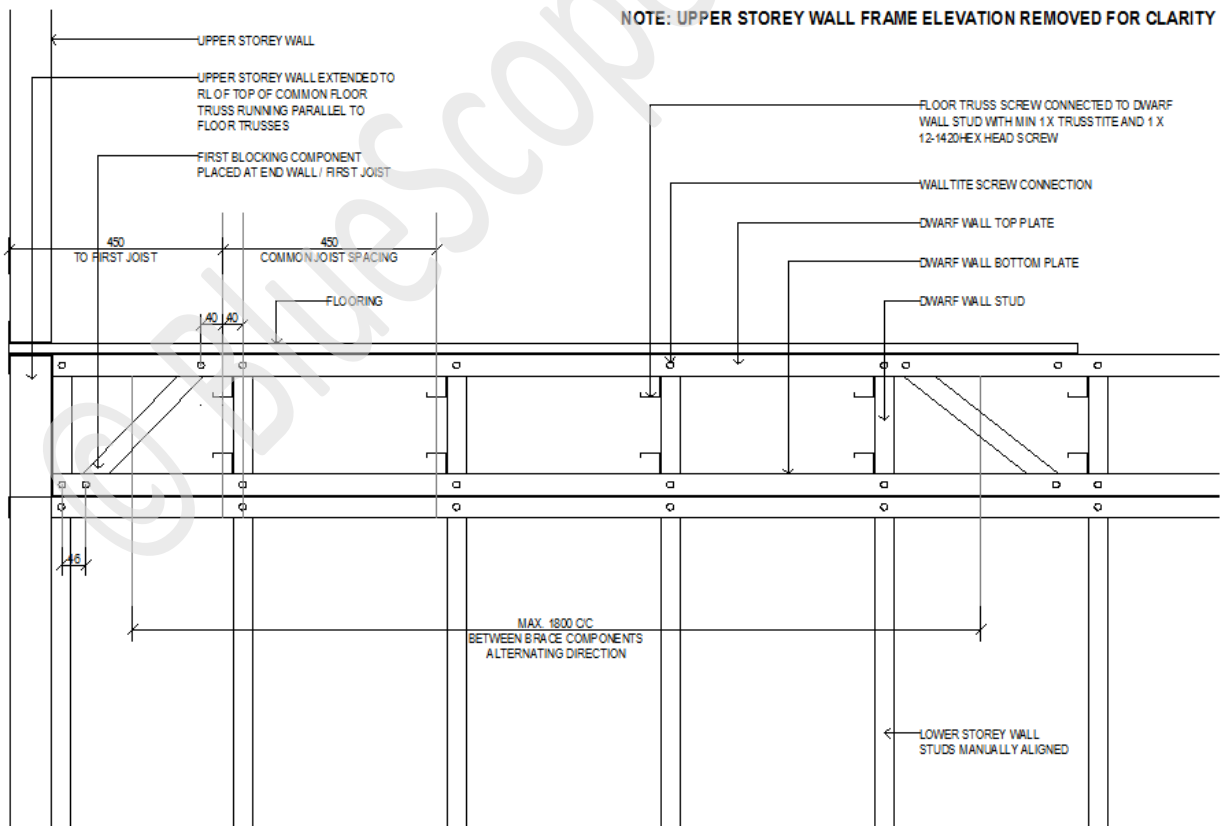

Step 10: Place end dwarf wall top plate into position and cap the top chords of the floor trusses and dwarf studs. Some moving of the floor components and dwarf studs may be necessary to facilitate correct location. (Ref item: 5)

Step 11: Fix all dwarf studs and roll-over restraint (angle stud) in place with 1 x Walltite® screw to both the inside and outside of the bottom plate.

Step 12: Install ceiling battens into place as indicated on the layout drawings.

Step 13: Install structural flooring to manufacturers recommendation or AS1860. Ensure the flooring used is suitable for the loading conditions and truss spacings.

Note: Feature strip flooring is not suitable for fixing directly to the top chords of ENDUROFLOOR™ trusses. It is recommended that a sheet floor is installed as a structural layer first with strip flooring being installed on the top surface as a decorative layer to AS1684.

Prefabrication

If the prefabrication method is used, most of the support structure is installed on site. Floors are generally made up of panels comprising of end dwarf walls with top and bottom plates pre-installed, floor trusses and structural flooring, that are transported to the worksite and lifted into place making for a more time and cost effective construction solution. The method of fabrication is virtually identical to the on-site method, except for the installation of lifting hardware and a specialist lifting team.

Step 1: Place relevant end dwarf wall bottom plates onto fabrication table. Note the location of the side flange notches to accommodate for the floor truss and supporting beam positions.

Step 2: If required, place primary support beams into place as indicated on the layout drawing. If necessary, pack to appropriate height as required.

Step 3: Install connection brackets to primary support beams for all secondary support trimming beams and floor trusses (Note: connection to be specified by suitably qualified engineer).

Step 4: If required, place secondary support beams into position and fix in place as specified (Note: connection to be specified by suitably qualified engineer).

Step 5: Install connection brackets to secondary support trimming beams for floor trusses (Note: connection to be specified by suitably qualified engineer).

Step 6: Install dwarf studs into correct location and fix with 1 x Walltite® screw to both the inside and outside of the bottom plate.

Step 7: Lift floor trusses into place taking note of the direction of the truss in relation to toes left/right and up/down.

Step 8: Fix floor trusses to side of dwarf wall studs at the pre-punched hole location with 1 x Trusstite® per hole. Provide reinforcing screws to each chord; the number reinforcing screws will be same as that provided for vertical end web.

Step 9: Place roll-over restraint (angle stud) at locations defined in the layout and fix with 1 x Walltite® screw to both the inside and outside of the bottom plate.

Step 10: Place end dwarf wall top plate into position. Some moving of the floor components and dwarf studs may be necessary to facilitate correct location.

Step 11: Fix all dwarf studs and roll-over restraint (angle stud) in place with 1 x Walltite® screw to both the inside and outside of the bottom plate.

Step 12: Install lifting hardware as specified.

Step 13: Install structural flooring to manufacturers recommendations or AS1860.2. Ensure the flooring used is suitable for the loading conditions and truss spacings.

Note: Feature strip flooring is not suitable for fixing directly to the top chords of ENDUROFLOOR™ trusses. It is recommended that a sheet floor is installed as a structural layer first with strip flooring being installed on the top surface as a decorative layer to AS1684.

Step 14: On-site, check dimensions of structural supports for compliance with floor truss layout to enable correct fitting.

Step 15: Check panel size for correct fitting prior to lifting into position.

Step 16: With the assistance of a specialist lifting team, safely lift floor panel into position and fix as specified by a suitably qualified engineer.

Step 17: Install ceiling battens into place as indicated on the layout drawings (Refer: Ceiling battens and plasterboard angles).

Integrated wall to floor system

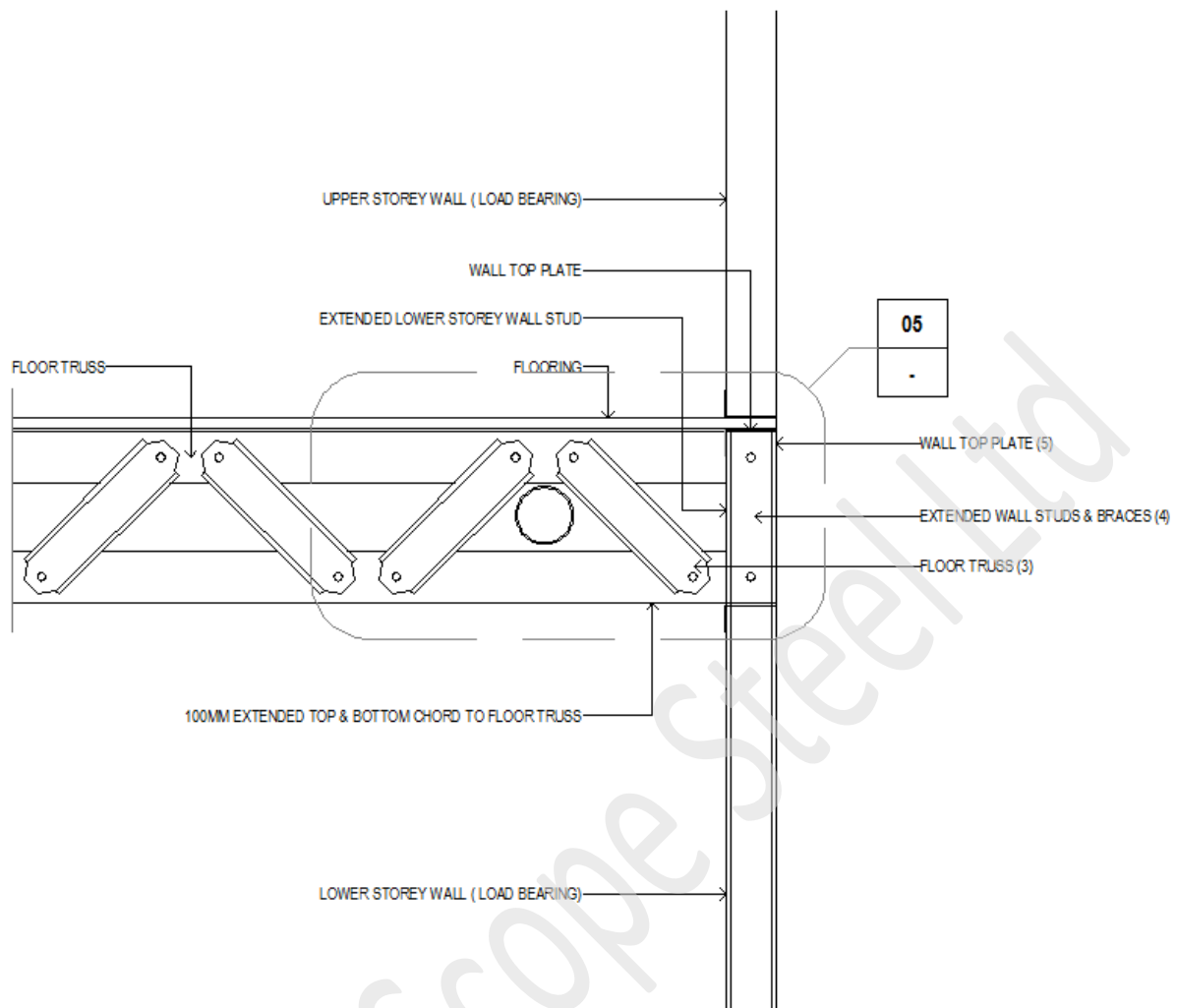

The integrated wall to floor system is best suited to full on-site installation as the support walls provide an integral support and restraint for the floor trusses at the supporting wall location.

Step 1: Using an appropriate driver tip, remove the top plates from the supporting walls and carefully place aside for re-use. (Ref item: 5)

Step 2: Lift primary support beams into place as indicated on the layout drawing. If necessary, pack to appropriate height as required.

Step 3: Install connection brackets to primary support beams for all secondary support trimming beams and floor trusses (Note: connection to be specified by suitably qualified engineer).

Step 4: Lift secondary support beams into position and fix in place as specified (Note: Connection to be specified by suitably qualified engineer).



Step 5: Install connection brackets to secondary support trimming beams for floor trusses (Note: Connection to be specified by

suitably qualified engineer).

Step 7: Lift floor trusses into place taking note of the direction of the truss in relation to toes left/right and up/down and correct location for fixing to the side of extended wall studs. (Ref item: 3)

© BlueScope Steel Ltd



Step 8: Fix floor trusses to side of extended wall studs at the pre-punched hole location with 1 x Trusstite® per hole.

Note: Where a balcony step down is present, the vertical chord on the floor truss is to be removed, with the extended wall studs being used in this position. The vertical chords have been installed for transportation and installation purposes only.

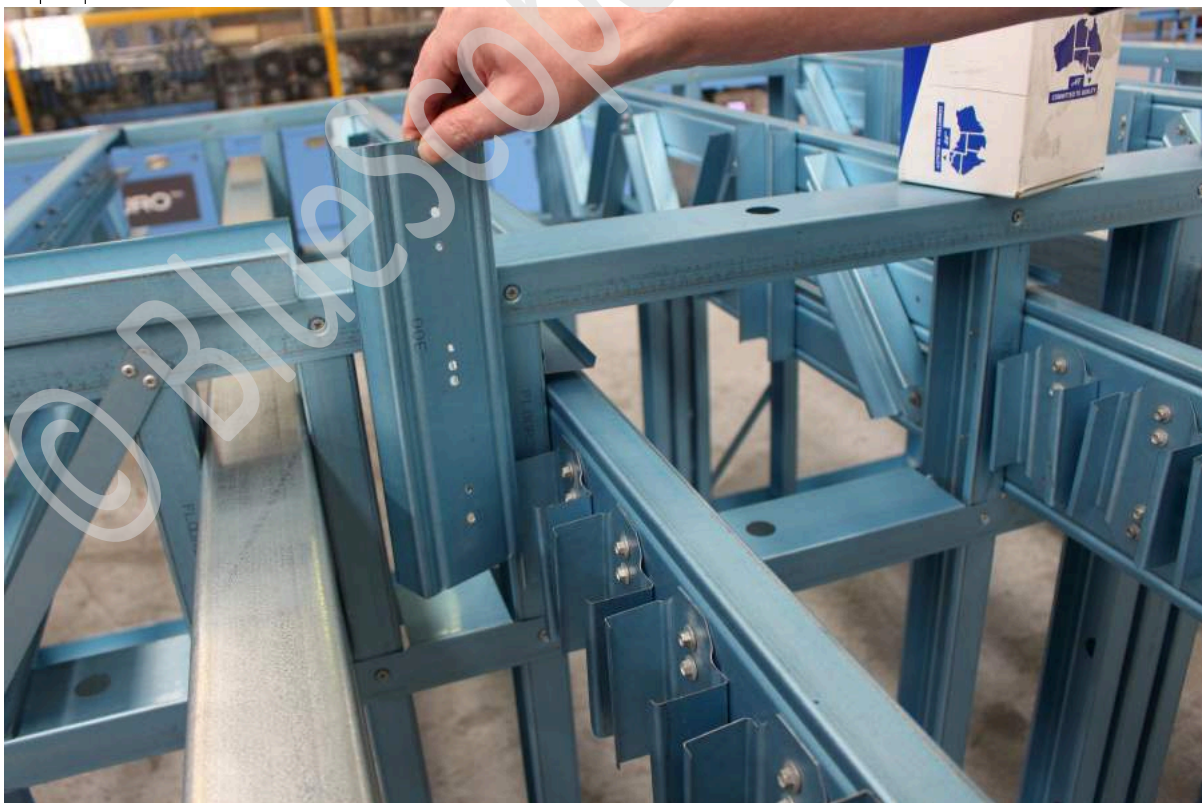
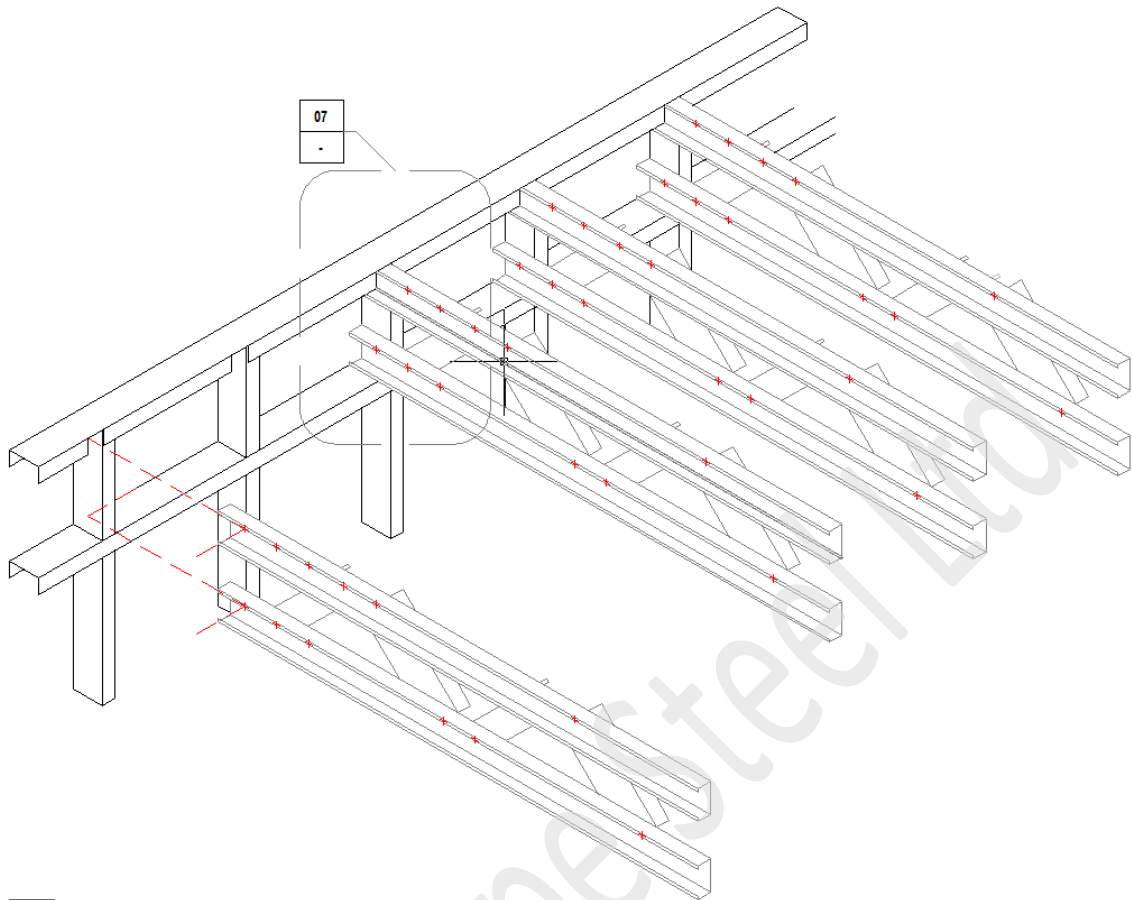

Step 9: Install any extra fixing screws at floor truss to extended wall stud junction as specified.

Step 10: Place top plate into position. Some minor moving of the floor components and extended studs may be necessary to facilitate correct location. (Ref item: 5)

Step 11: Fix all extended wall studs in place with 1 x Walltite® screw to both the inside and outside of the top plate.

Step 12: Install ceiling battens into place as indicated on the layout drawings (Refer: Ceiling battens and plasterboard angles).

Step 13: Install structural flooring to manufacturers recommendation or AS1860.2. Ensure the flooring used is suitable for the loading conditions and truss spacings.

Note: Feature strip flooring is not suitable for fixing directly to the top chords of ENDUROFLOOR™ trusses. It is recommended that a sheet floor is installed as a structural layer first with strip flooring being installed on the top surface as a decorative layer to AS1684.

End wall lintel

The end wall lintel system is a simple method of construction where a common floor truss with vertical and horizontal webs are placed onto a supporting wall and beam system. Rollover restraint is accommodated by the installation of a 200x35x1.5mm angle lintel as commonly used in the ENDUROWALL® system.

Where a lintel is specified to be installed at the end of floor trusses, fix in place with 3 x 12-14 x 20mm Hex Head self drilling screws through the face of the lintel into the vertical chord of the floor trusses.

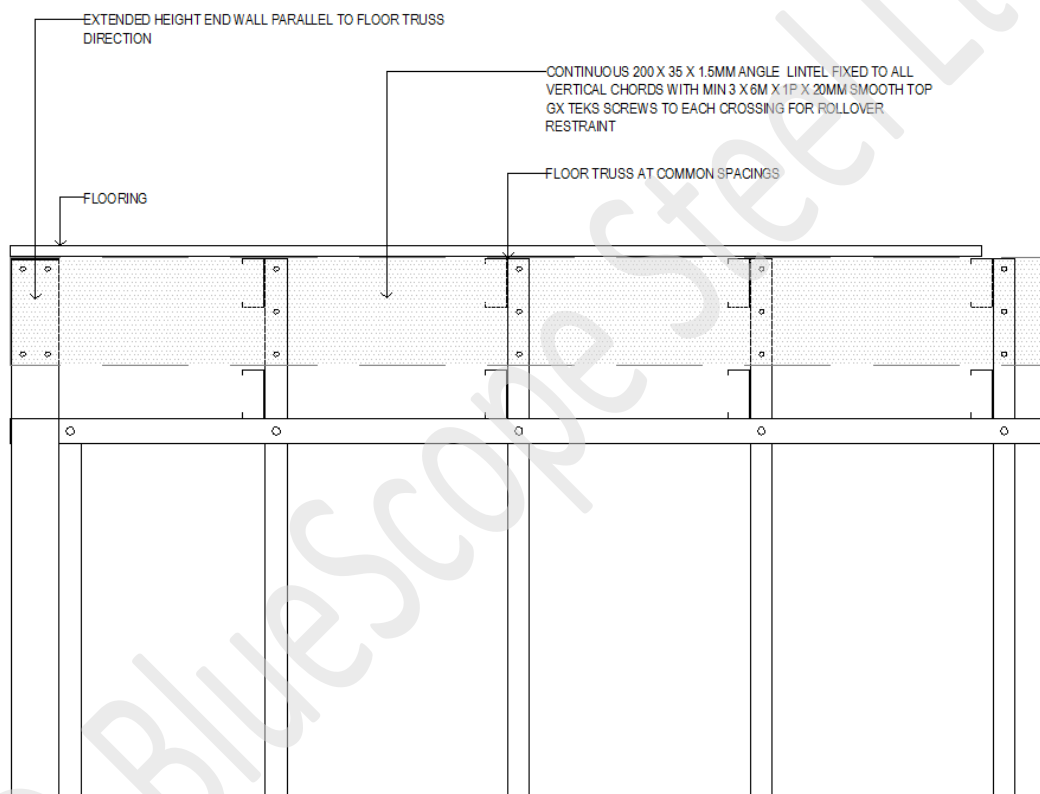

Step 1: Mark position of all floor components as indicated on the layout drawing.

Step 2: Lift primary support beams into place as indicated on the layout drawing. If necessary, pack to appropriate height as required.

Step 3: Install connection brackets to primary support beams for all secondary support trimming beams and floor trusses (Note: Connection to be specified by suitably qualified engineer).

Step 4: Lift secondary support beams into position and fix in place as specified (Note: Connection to be specified by suitably qualified engineer).

Step 5: Install connection brackets to secondary support trimming beams for floor trusses (Note: Connection to be specified by suitably qualified engineer).

Step 6: Lift floor trusses into place taking note of the direction of the truss in relation to toes left/right and up/down.

Step 7: Fix floor trusses to top plate at the correct locations with 1 x 12-14 x 20mm hex head self drilling screw. Alternative tie down types may be specified and should also be fixed at this stage.

Step 8: Once floor trusses are in position, place angle lintel into position. Some minor moving of the floor components may be

necessary to facilitate correct location.

Step 9: Check plumb of floor components and once correct, install 3 x 12-14 x 20mm Hex Head self drilling screws through the face of the lintel into the vertical chord of the floor trusses.

Step 10: Install ceiling battens into place as indicated on the layout drawings (Refer: Ceiling battens and plasterboard angles)

Step 11: Install structural flooring to manufacturers recommendation or AS1860.2. Ensure the flooring used is suitable for the loading conditions and truss spacings.

Note: Feature strip flooring is not suitable for fixing directly to the top chords of ENDUROFLOOR™ trusses. It is recommended that a sheet floor is installed as a structural layer first with strip flooring being installed on the top surface as a decorative layer to AS1684.

Ensure that a screw is located at the cross-over point of the flooring, angle lintel and the floor truss top chord flange.

Ceiling battens and plasterboard angles

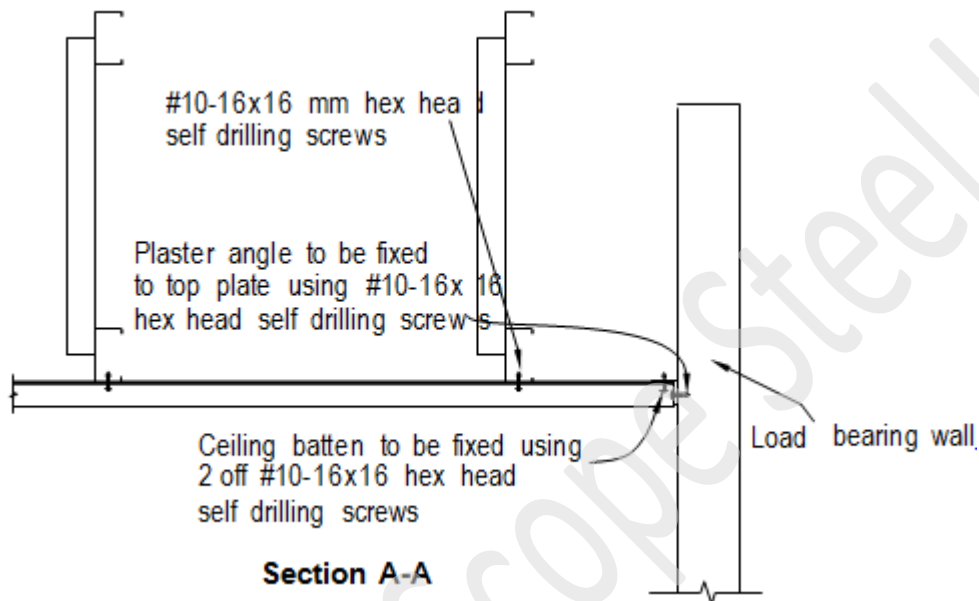

As indicated in the floor construction steps, ceiling battens must be fitted immediately after the floor trusses have been installed. By fixing the ceiling battens at this stage the floor trusses will be laterally restrained without the need of bottom chord ties.

Step 1: When all floor trusses are installed, install ceiling battens to the underside of the bottom chords. Ceiling battens can be spaced at 600mm centres or 450mm centres depending on the type of plasterboard that will be used for the ceiling (check the plasterboard manufacturers specifications). Ceiling batten sizes shall be selected from batten manufacturer's technical literature and sized to suit span, spacings and loads.

NOTE: Ceiling battens spacing is dependent on ceiling lining. For suspended ceilings, lateral restraints must be provided at spacings specified Floor Truss Layout Sheet.

Step 2: Fix the ceiling battens with two #10-16x16mm hex head self drilling screws, one into each flange of the batten into the bottom chord of the floor truss.

Step 3: Plasterboard angle must be used at the intersection of the ceiling batten/load bearing wall junction to support the ends of the ceiling battens.

Internal wall support and shear transfer

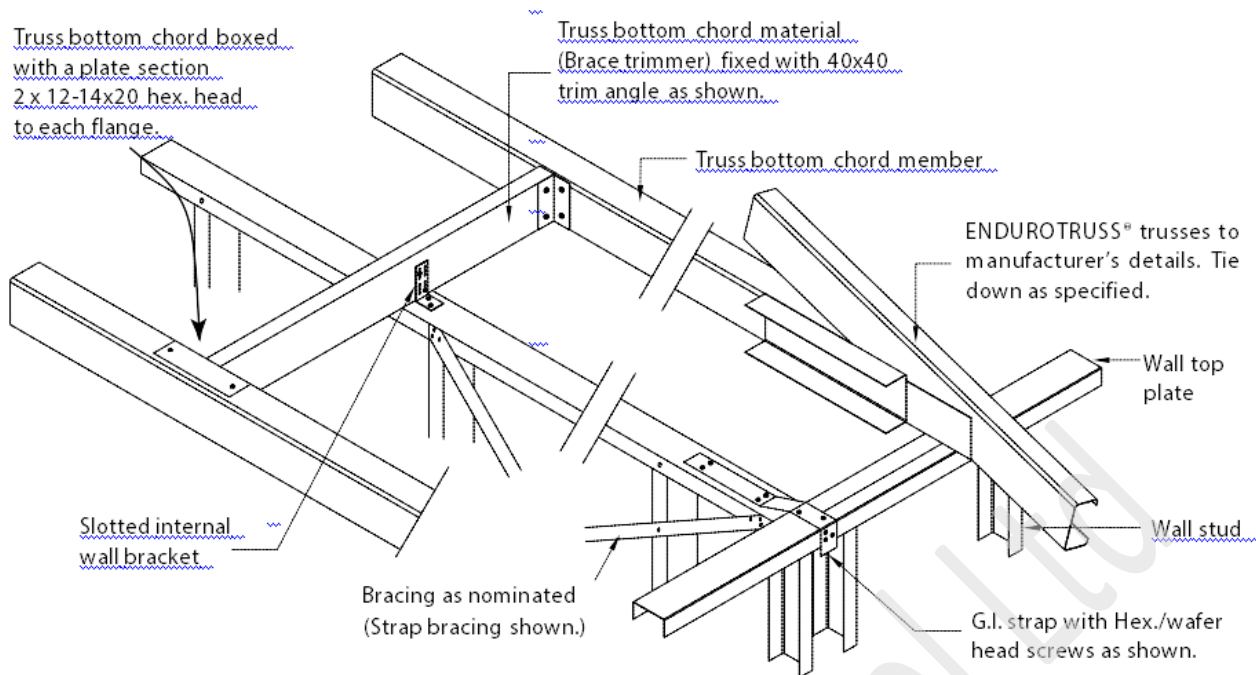

It is important that the truss can move up and down in this bracket so screws should be able to slide. To enable the trusses to slide ensure the fastener is placed in the middle of the slot and it is not over tightened.

For shear transfer, refer to Wall Installation manual.

Step 1: Fix one #10-16x16mm hex head self drilling screw down through the top of the bracket and into the top of the ceiling batten to stop the bracket sliding.

Step 2: Bend the bracket down to the top plate of the internal wall and fix two #10-16x16mm hex head self drilling screws through the foot of the bracket into the top plate.

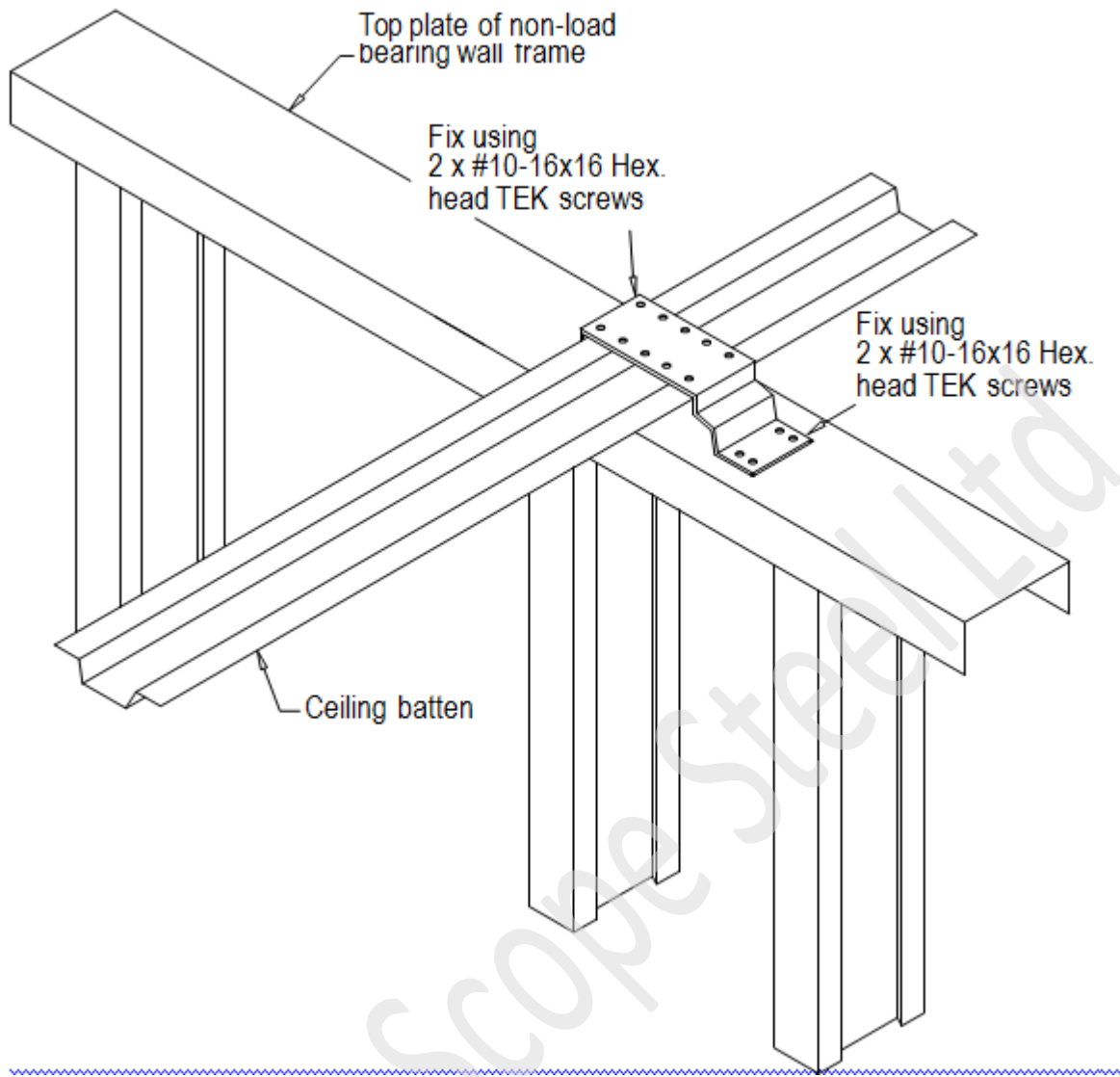

Step 3: Install hitch brackets to the bottom chord of floor trusses at a maximum of 1200mm centres. Fix two #10-16x16mm hex head self drilling screws into the side of the flat face of the bottom chord.

Step 4: Fix two #10-16x16mm hex head self drilling screws through the foot of the bracket into the top plate.

Installation of flooring

All flooring is to be installed in accordance with the manufacturers recommendations or AS1860.2.

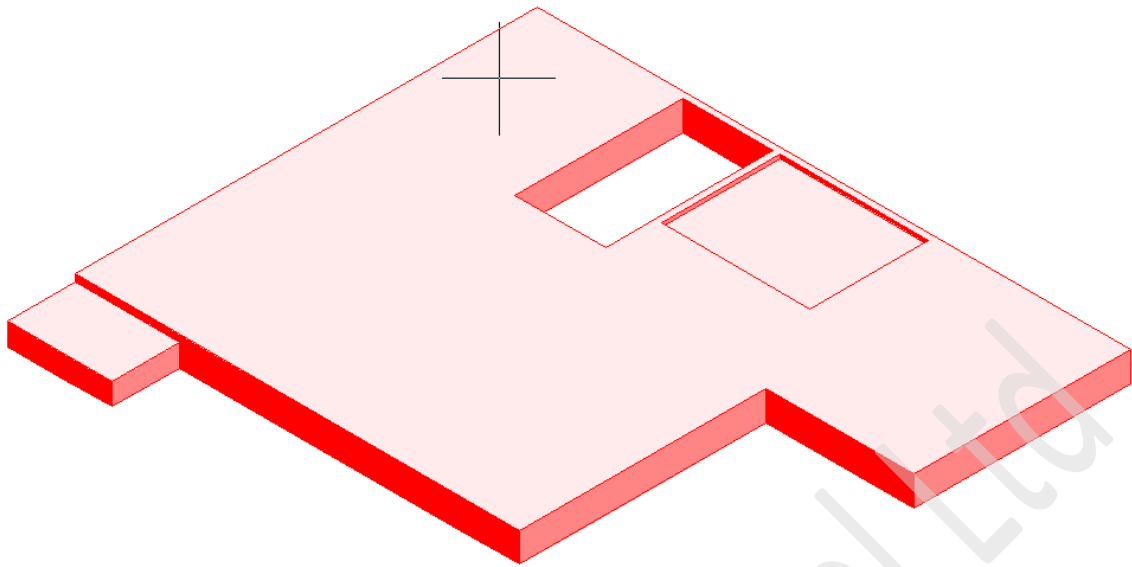

Picture
Size
Application
Part No.



200 x 35 x 1.5
Single lintel used to resist roll-over of floor trusses at ends.