

Crown rafter detail

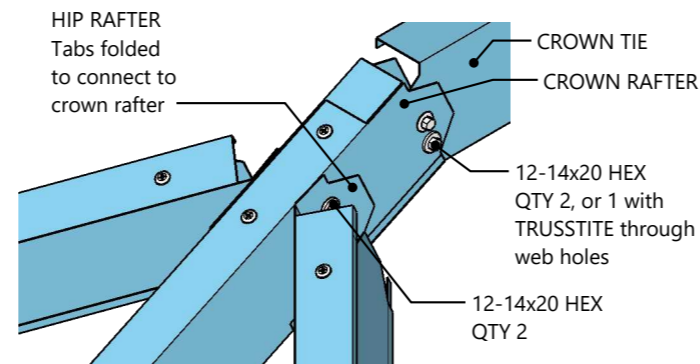

Crown rafter, reverse view

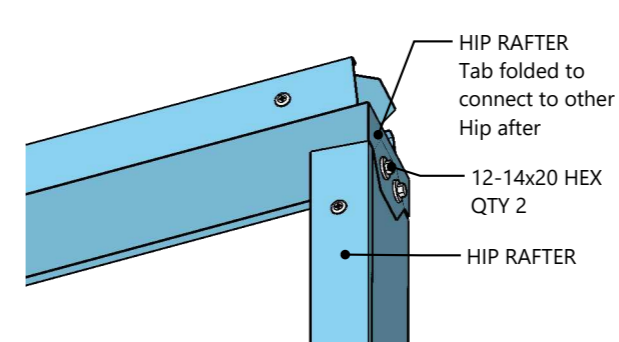

Option without crown rafter

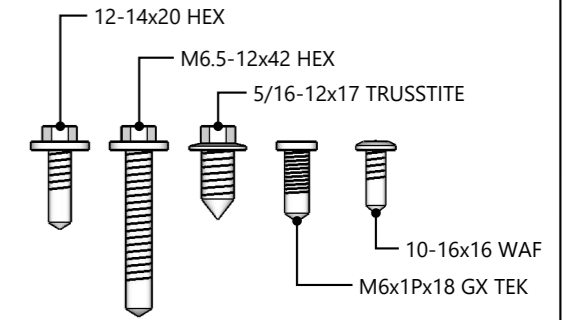

Fasteners

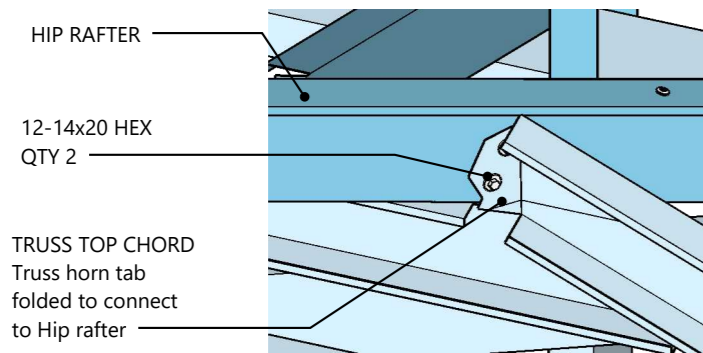

Truss horn to hip rafter connection

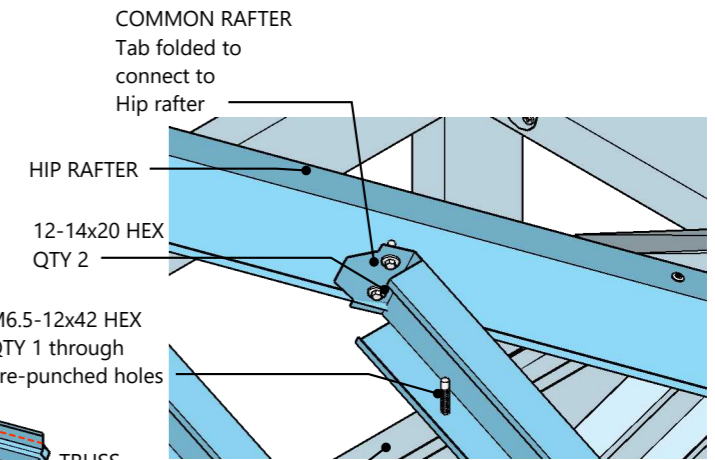
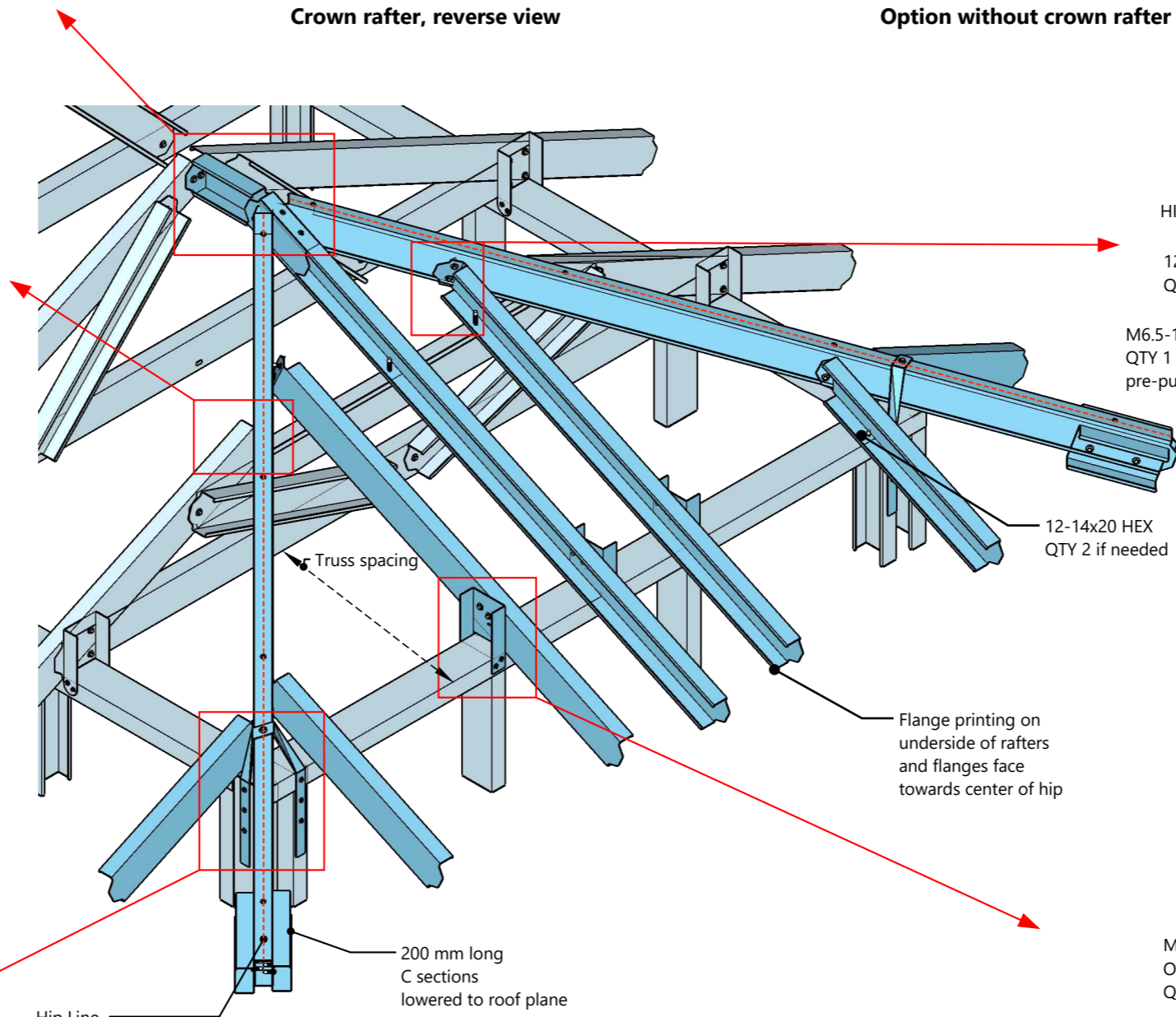

Common rafter detail

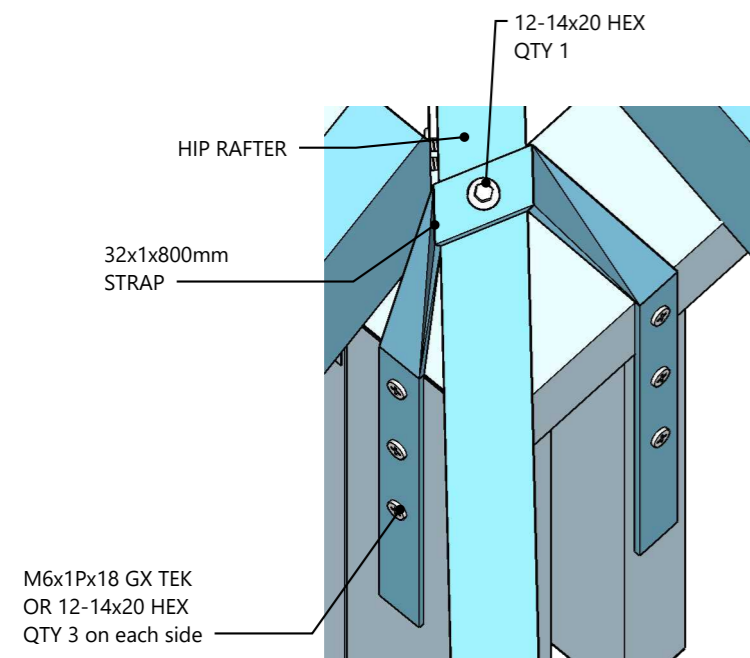

Hip rafter to wall tiedown

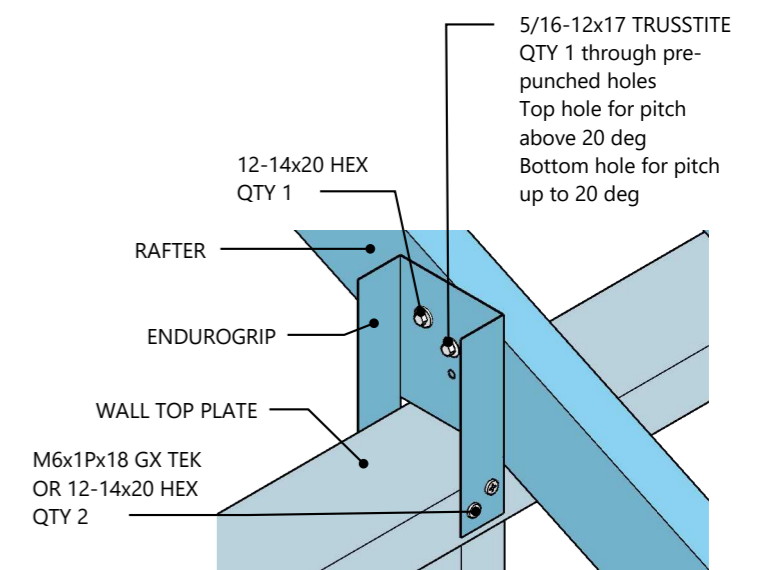

Rafter to wall tiedown

REVISIONS		
DD/MM/YYYY	REMARKS	
1	19/05/2021	ENDUROCAD® software v11.01.28
2		
3		
4		