

Crown rafter detail

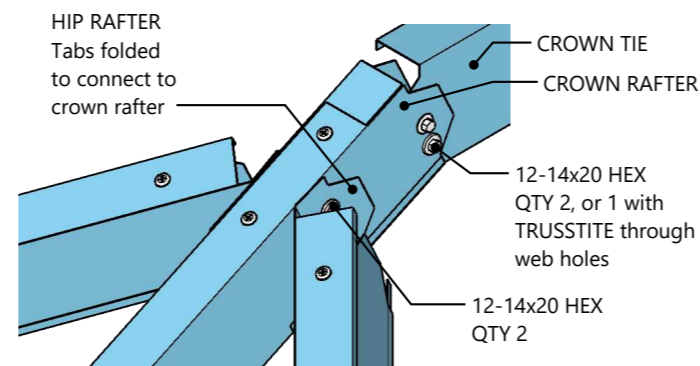

Crown rafter, reverse view

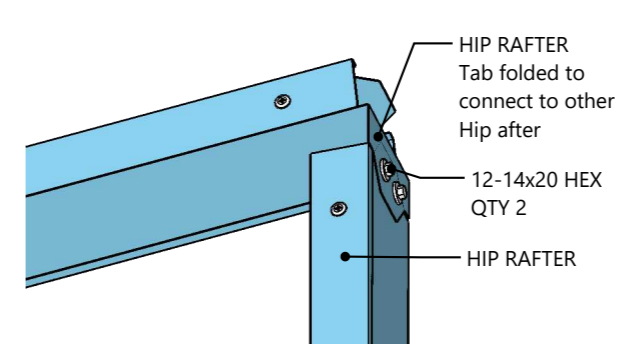

Option with no crown rafter

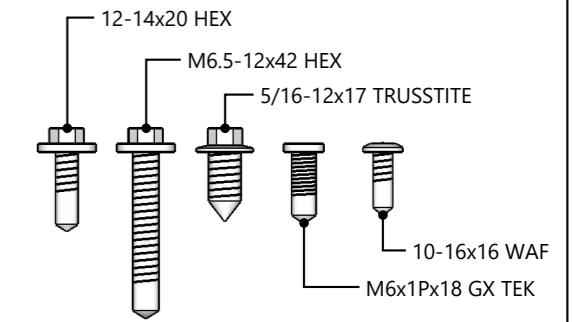

Fasteners

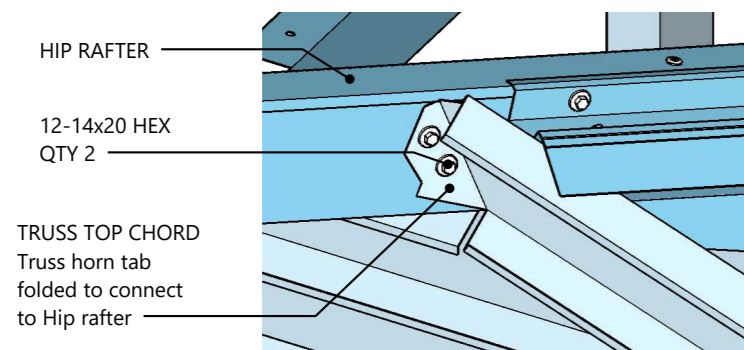

Truss horn to hip rafter connection

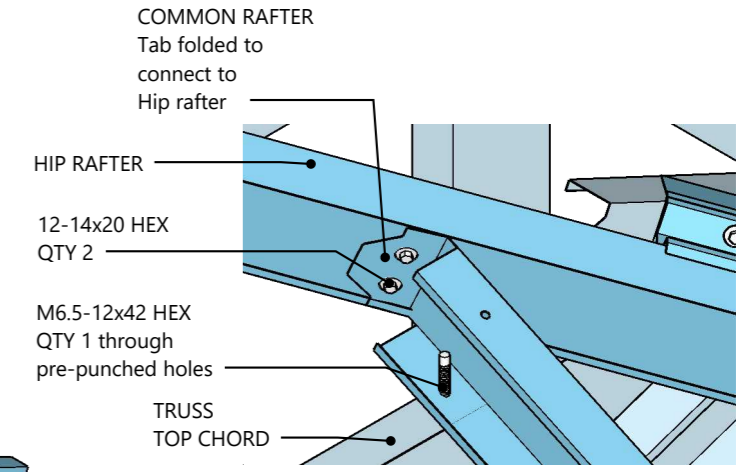
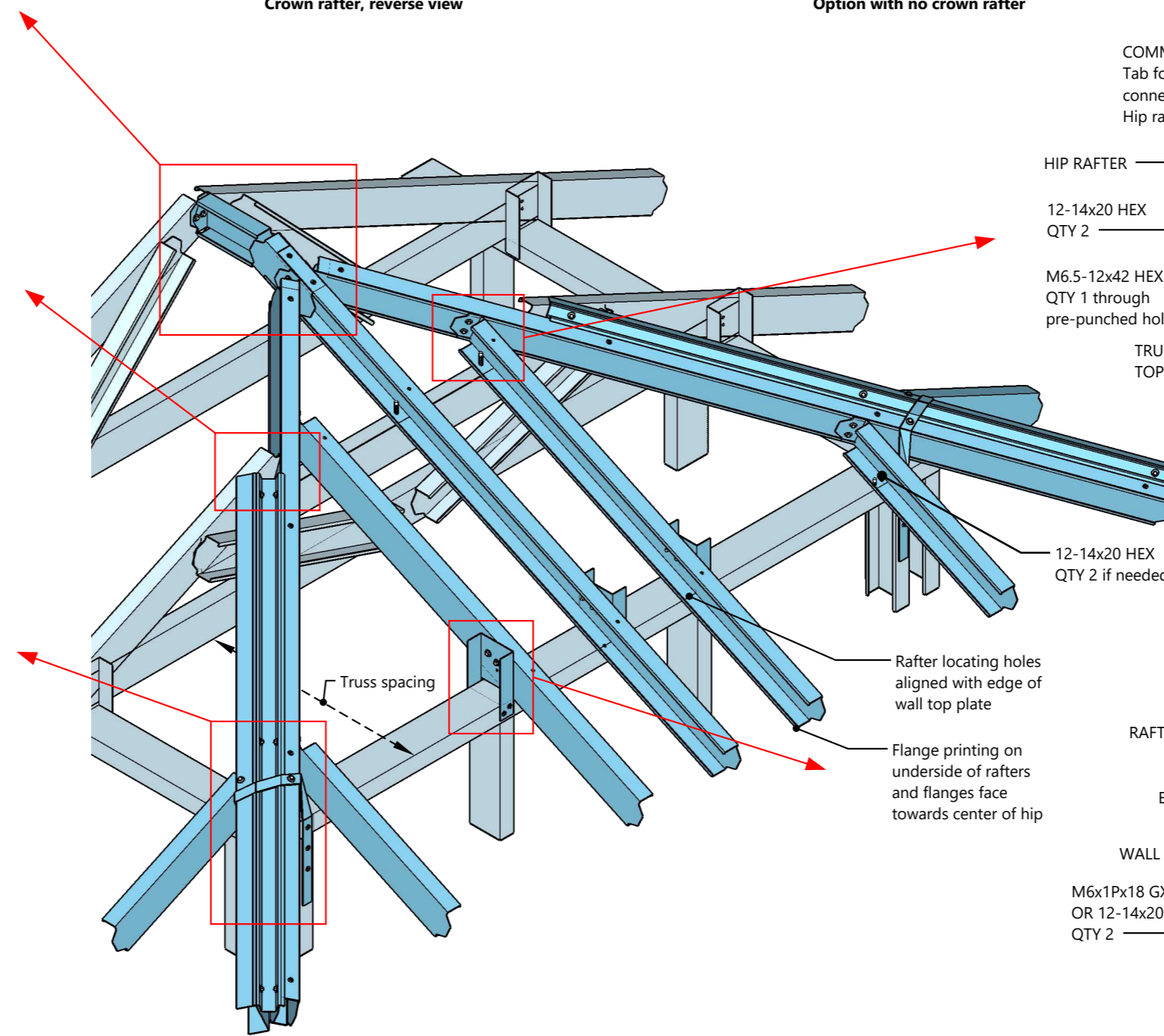

Common rafter detail

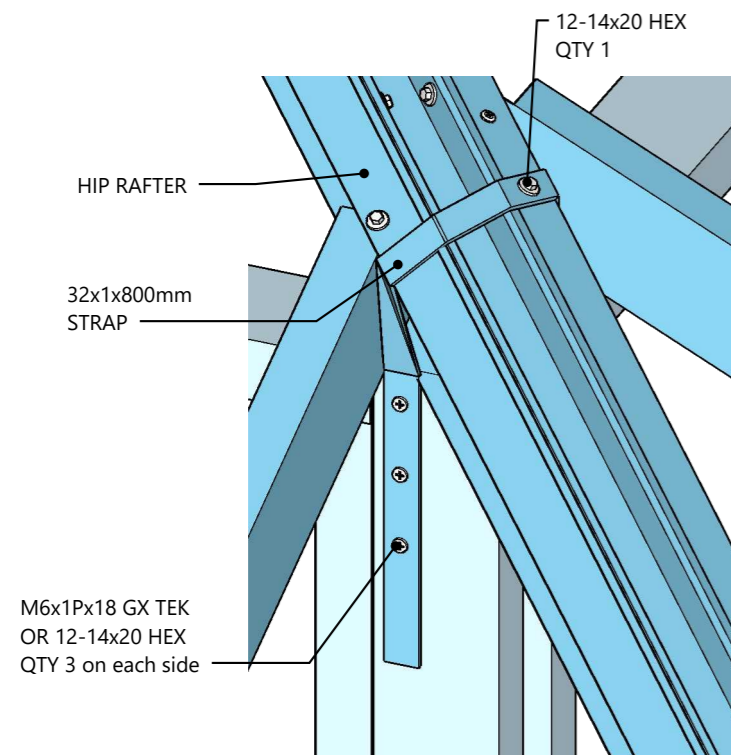

Hip rafter to wall tiedown

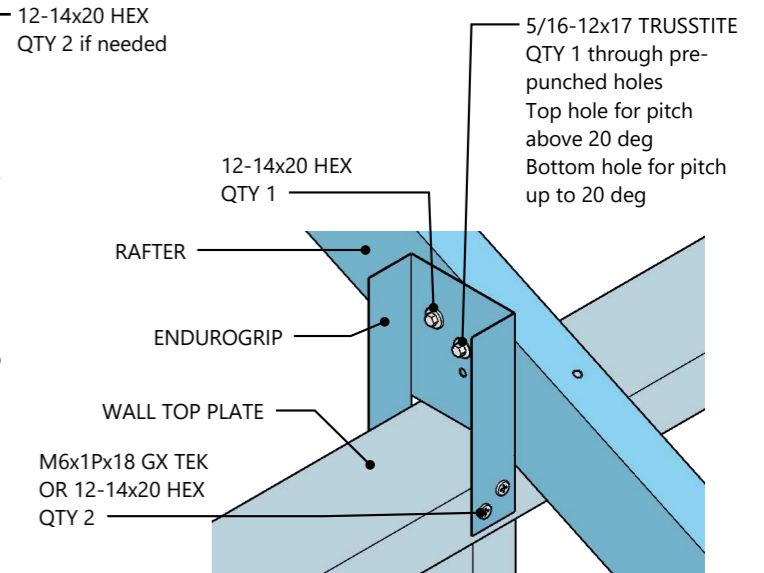

Rafter to wall tiedown

REVISIONS		
DD/MM/YYYY	REMARKS	
1	15/06/2020	DRAFT 6, ENDUROCAD <sup>®</sup> software v11.00.07
2		
3		
4		